

390D L

Hydraulic Excavators



Engine

Engine Model	Cat® C18 ACERT™ (ATAAC)	
Net Power – ISO 9249	390 kW	523 hp
Net Power – SAE J1349	390 kW	523 hp

Drive

Maximum Travel Speed	4.5 km/h	2.8 mph
Maximum Drawbar Pull	590 kN	132,637.25 lb

Weights

Operating Weight – Long Undercarriage	86 190 kg	190,016 lb
• 8.4 m (27.5 ft) GP boom, R4.4 m (14.4 ft) stick, 4.6 m³ (6.0 yd³) HD bucket and 650 mm (26 in) shoes.		

Features

Performance

High level of sustained production, improved performance, reliability and durability increase your productivity and lower your operating costs.

Engine

The Cat® C18 engine uses ACERT™ Technology to meet U.S. EPA Tier 3 emission regulations with exceptional performance capabilities and proven reliability.

Operator Station

Superior cab comfort and visibility provide an excellent working environment. The full-color monitor with graphic display features enhanced functionality to provide a simple, comprehensive machine interface.

Maximum Versatility

A variety of work tools, including buckets, are available for applications such as demolition, site clean-up, scrap processing, breaking up road surfaces and bedrock through Cat® Work Tools.

Service and Maintenance

Fast, easy service has been designed in with long service intervals, advanced filtration, convenient filter access and user-friendly electronic diagnostics for increased productivity and reduced maintenance costs.

Contents

Hydraulics	3
Operator Station.....	4
Engine	5
Control System	6
Structures.....	7
Undercarriage	8
Front Linkage	9
Buckets and Teeth	10
Work Tools.....	11
Environment	12
Service and Maintenance	13
Complete Customer Support.....	14
Hydraulic Excavator Specifications	15
Standard Equipment.....	28
Optional Equipment.....	29
Notes.....	30



The Cat® 390D L Hydraulic Excavator has excellent control, high stick and bucket forces, impressive lift capacity, simplified service and a comfortable operator station to increase your productivity and lower operating costs.

Hydraulics

Precise power and control to move more material

Main Pumps

The hydraulic system includes three pumps with an independent swing circuit. The hydraulic circuit utilizes a load-sensing system to ensure high efficiency and productivity with little hydraulic loss.

Swing Dampening Valve

A swing dampening valve reduces wagging, which produces smoother, time-saving swing stops.

Implement Pressure

Increased implement pressure provides shorter cycle times, stronger digging forces and greater bucket fill factors.

Auxiliary Hydraulics

Standard auxiliary hydraulics are managed electronically, making the machine more versatile.

Proportional Priority Pressure Compensation (PPPC) Hydraulics

The load-sensing PPPC system with proprietary electronic actuation provides excellent efficiency and controllability.

- Pump discharge flow matches the operator's desired speed, which makes for extremely smooth shifting from neutral to full stroke.
- Pump flow volume all goes to the actuator, which ensures the delivery of maximum hydraulic energy.
- Even if load pressure changes during actuation, the control lever position does not vary, which makes for consistent, reliable operation.



Operator Station

Simple and comfortable for maximum productivity



Cab Design

The spacious cab provides excellent visibility and ergonomics. The full-color monitor provides the operator with easy-to-read, comprehensive machine information.

Cab Exterior

The cab utilizes thick steel tubing along the bottom to reduce vibration and fatigue. The cab structure allows the FOGS to be bolted directly to the cab either at the factory or as an attachment.

Cab Mounts

The cab shell is attached to the frame with viscous rubber cab mounts, which dampen vibrations and sound levels to enhance operator comfort.

Additional Features

The 390D L operator station has many features for operator comfort.

- Premium air suspension seat with adjustable/tilt console.
- Low effort joysticks.
- Numeric view of fuel consumption on the monitor.
- Optional rearview camera for added safety.
- Optional HID (High Intensity Discharge) lights with time delay for the boom and cab lights.
- Two-way radio-ready option.



Engine

Power to move more dirt with less fuel

Cat® C18 Engine

The C18 engine with ACERT™ Technology powers the 390D L. The C18 has a proven record of long life. Materials like high-strength steels and cast iron contribute to its durability, while uniquely designed water-cooled turbochargers and mechanically actuated fuel injection contribute to its reliability.

Improved Fuel Efficiency

The 390D L optimizes fuel consumption through flexible power settings incorporated into the ADEM™ controller, which electronically manages engine response to load demand. The operator can select High Production, Standard or Economy mode to meet application requirements.

Hydraulic Cooling Fans

The 390D L uses hydraulically driven cooling fans that operate based on coolant and hydraulic oil temperatures. To reduce load when cranking the engine, the cooling fan speed is fixed for a set amount of time after the engine is started and then is increased gradually to a specific speed.

Reversible Fan

A reversible fan option is offered to help clean the cooling package for increased uptime and reduced service cost.

Control System

Easy to view, easy to manage



Monitor Display

The monitor is a full-color Liquid Crystal Display (LCD). A master caution lamp blinks ON and OFF when one of the critical conditions below occurs:

- Engine oil pressure low
- Coolant temperature high
- Hydraulic oil temperature high

Under normal conditions or the default condition, the monitor display screen is divided into four areas: clock and throttle dial, gauge, event display and multi-functional display.

Gauge Display

Three analog gauges – fuel level, hydraulic oil temperature and coolant temperature – are displayed in this area.

Pattern Control Changer

The standard hand control pattern changer can be accessed through the monitor to utilize either the standard excavator control pattern or backhoe loader pattern, making it easier for operators to work in the mode they are accustomed.

Electronic Joysticks

Electronic joysticks provide features not possible with hydraulic pilot valves:

- Eliminate pilot lines in cab for quieter operation
- Simple pattern change through the monitor

Operator Gain/Response

This is used to suit the operator preference or application.

- Faster for quick response
- Slower for more precision

Product Link

Product Link is a proprietary Caterpillar technology that tracks machine location, product health, hours of use and fuel consumption. This information is transmitted back to customers to help maximize machine productivity.

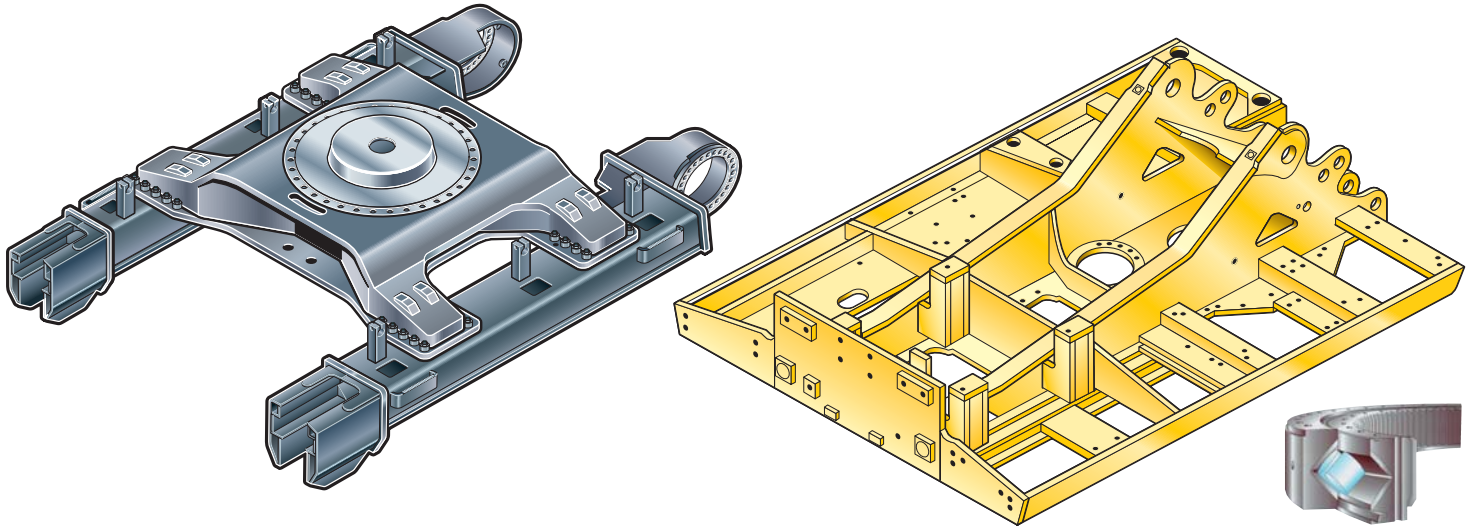

Structures

Rugged and durable for many applications

Variable Gauge Undercarriage

The long variable gauge undercarriage is standard, providing a wide, stable base for operating or a narrow gauge for reduced shipping width. Changes to the 390D L undercarriage include:

- Improved track link to reduce and avoid stresses
- Improved carrier rollers to reduce the risk of leaking lubrication oil
- Improved forged idler for added durability in severe underfoot conditions
- Positive Pin Retention 2 (PPR2) to prevent pin movement

Counterweight

The 390D L has two counterweights available – both heavier to accommodate the reinforced front linkage.

Catwalks

Slip-resistant catwalks are 500 mm (19.5 in) wide and stretch the length of the machine to safely provide access to major service points.

Track Roller Frame

The thick, steel-plated track roller frame is welded into a box structure, which provides increased rigidity and impact resistance.

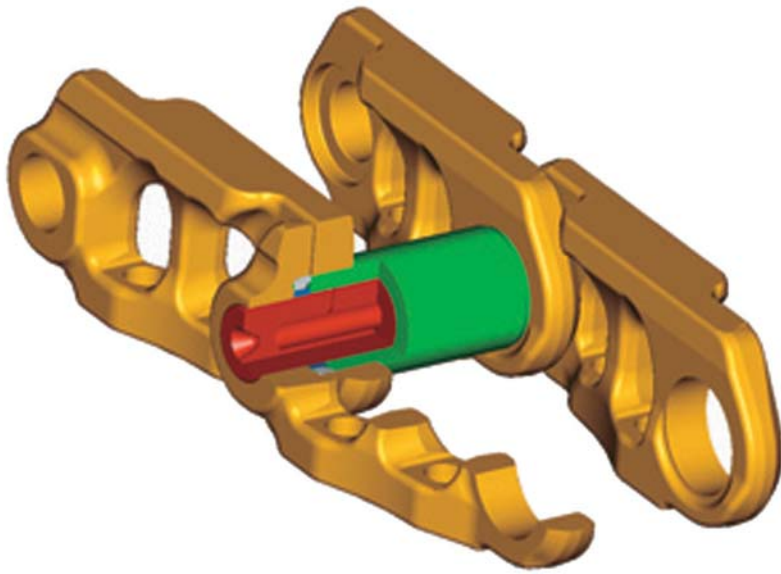

Undercarriage

Strong, stable and durable

Undercarriage

The undercarriage supports the swing bearing and upper structure and is the link that transmits the reaction forces from digging to the ground. The strength of the Cat undercarriage plays a major factor in machine stability and durability.

Track Roller Frame

The track roller frame has been improved by installing a longer stroke recoil spring and lowering the front idler. The longer recoil spring improves durability and service life of the undercarriage, and the offset idler increases the stability of the machine while working over the front.

Positive Pin Retention 2 (PPR2)

Track links with the PPR2 are provided as standard on the 390D L. The PPR2 is designed to prevent looseness of the track pin in the track link and to reduce stress concentrations. The PPR2 system eliminates pin movement for increased service life.

Carrier Rollers

The carrier rollers use a floating Duo-Cone seal, which reduces the risk of leaking lubricating oil.

Front Linkage

Built to perform the toughest tasks

Front Linkage

Cat® Excavator booms and sticks are built for performance and long service life.

- Castings and forgings are used at high stress areas such as the boom nose, boom foot, boom cylinder and stick foot.
- All booms and sticks are stress-relieved for optimal life and durability while minimizing weight for improved performance.
- All booms and sticks are ultrasonic inspected to ensure reliability.

Bucket Linkage

Two bucket linkages are available for the 390D L. Both are available with or without a lifting eye.

Boom Construction

390D L booms feature a large cross section to improve strength, reduce weight and maximize payload. Baffle plates reinforce the boom interior for higher rigidity.

Stick Construction

Sticks are made of high-tensile strength steel in a box-section design, making them strong and light. All sticks are reinforced with a thick baffle plate for added rigidity. The connection between stick and boom is made of forged steel, and a thick steel plate is used at the bucket connecting location for increased strength and rigidity at load-bearing points. An additional wear plate is added to the bottom plate to protect against damage. There are two reach sticks, three general purpose sticks and two mass sticks available to meet your needs.

Linkage Pins

All front linkage pins have thick chrome plating, giving them high wear resistance. Each pin diameter is made to distribute the shear and bending loads associated with the stick and to help ensure long pin, boom and stick life.

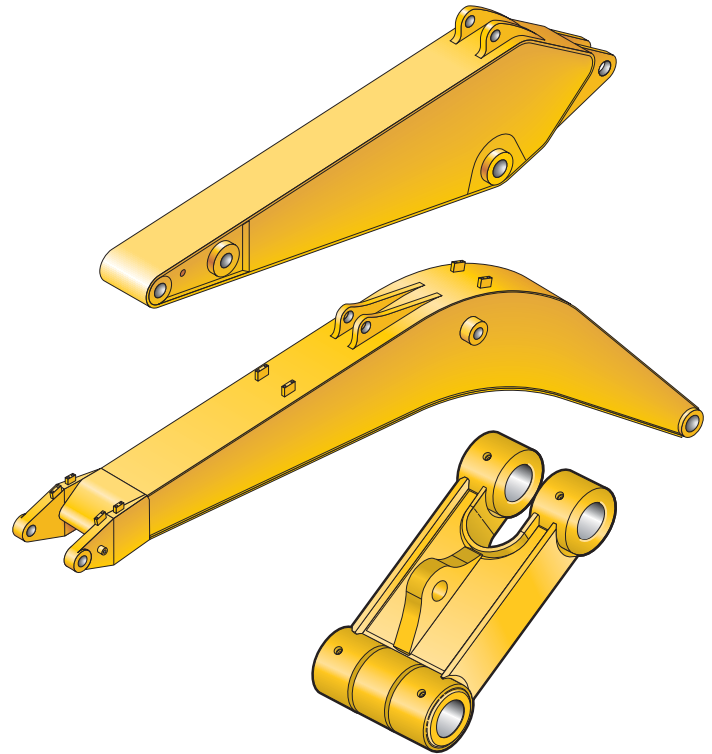

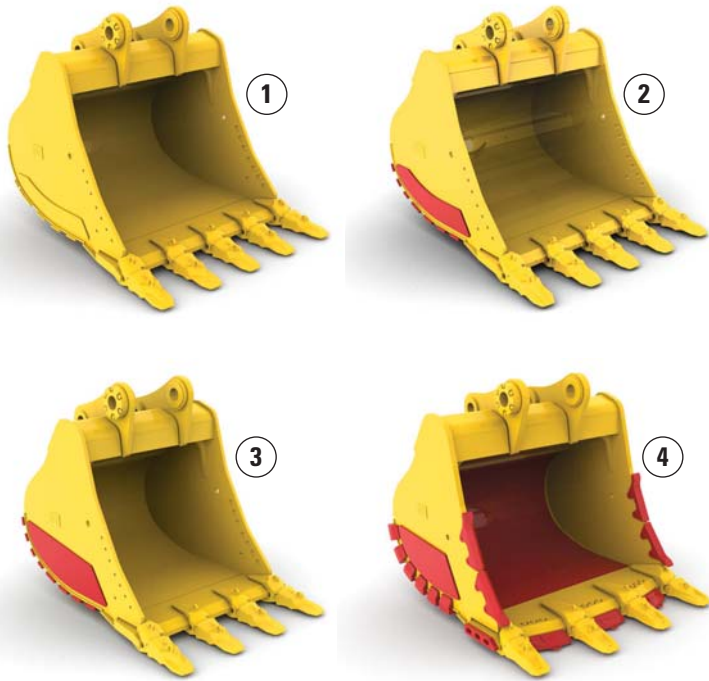

Buckets and Teeth

Designed and built for rugged work

Optimized Package

Caterpillar offers a wide range of buckets – each designed and field tested to function as an integral part of your excavator. All Cat® Buckets feature K Series™ Ground Engaging Tools (GET). Buckets are available in four levels of durability and are built to take full advantage of the machine's power.

General Duty (GD)

General Duty buckets are designed for use in low impact, low abrasion material such as dirt, loam and mixed compositions of dirt and fine gravel.

Heavy Duty (HD)

Heavy Duty buckets are the most popular and a good “centerline” choice. This bucket style is a good starting point when application conditions are not known. Heavy Duty buckets are designed for a wide range of impact and abrasion conditions, including mixed dirt, clay and rock.

Severe Duty (SD)

Severe Duty buckets are designed for higher abrasion conditions such as shot granite. When compared to the Heavy Duty bucket, wear bars and wear plates are substantially thicker and larger for added protection.

Extreme Duty (XD)

Extreme Duty buckets are designed for very high abrasion conditions such as granite quarries. Corner shrouds have been added, and side wear plates are larger for added protection.

1) General Duty 2) Heavy Duty 3) Severe Duty 4) Extreme Duty

Work Tools

Solutions for many applications

Increase Machine Versatility

The Cat combination of machine and tool provides a total solution for just about any application. Work tools can be mounted either directly to the machine or to a quick coupler, making it fast and easy to release one work tool and pick up another.

Couplers

Caterpillar offers two quick coupler styles: dedicated and pin grabber. Each allows quick tool changes.

Center-Lock™ Pin Grabber Coupler

Center-Lock is the Cat pin grabber style coupler and features a patent pending locking system. A highly visible secondary lock clearly shows the operator when the coupler is engaged or disengaged from the bucket.

Work Tools

An extensive range of Cat Work Tools for the 390D L includes buckets, grapples, shears, multi-processors and rippers. Each is designed to optimize the versatility and performance of your machine. Cat Work Tools and couplers are ready to work in a variety of applications, such as site and structure demolition, debris clean-up, truck loading, scrap processing and breaking road surfaces and bedrock.

Hydraulic Kits

Caterpillar offers field-installed hydraulic kits designed to simplify the process of ordering and installing the right kit. Modular kit designs integrate Cat Work Tools with Cat Hydraulic Excavators. Every kit is easy to install. Hoses are pre-made, tubes are pre-bent and pre-painted and there are comprehensive instructions.





Environment

Built to meet a range of requirements

Emissions

ACERT™ Technology is a differentiated technology that reduces emissions at the point of combustion. It capitalizes on proven Caterpillar leadership in three core engine systems: fuel, air and electronics.

Electro Magnetic Compliance

The 390D L meets the following EMC (Electro Magnetic Compliance) requirements:

- ISO 13766 Earth Moving Machinery – Electromagnetic compliance
- EU Directive 89/336/EEC
- Aus EMC Framework

Fluid Management

Many serviceability elements are designed into the 390D L to limit fluid spillage while performing routine maintenance.

Filters

Hydraulic return filters are vertically mounted, capsule-type with shutoffs in the inlet and outlet ports.

Ecology Drains

Ecology drains for the fuel and hydraulic tanks allow fluids to be captured in a container when draining the tanks.

Certified Rebuild

When most other manufacturers' models require replacement, Cat equipment can be rebuilt using many remanufactured parts. This means less materials going to landfills.

Service and Maintenance

Fast, easy and safe access is built in

Service Intervals

Long service intervals reduce maintenance costs. Engine oil, oil filter and fuel filters are rated at 500 hours.

Oil Sample and Pressure Ports

Oil sample and pressure ports provide easy checking of machine condition and are standard on every machine.

Hydraulic Capsule Filters

The return filters or capsule filters for the hydraulic system are located beside the hydraulic tank. The filter elements are removable without spilling hydraulic oil.

Service Points

Service points are centrally located with easy access to facilitate routine maintenance.

Pilot Hydraulic System Filter

A pilot hydraulic system filter keeps contaminants from the pilot system and is located in the pump compartment.

Remote Greasing Block

A concentrated remote greasing block on the boom delivers grease to hard-to-reach locations.

Radial Seal Cleaner

The radial seal main air cleaner with precleaner has a double-layered filter element for more efficient filtration. No tools are required to change the element.

Fuel-Water Separator

The fuel-water separator removes water from fuel, even when under pressure, and the water level can be monitored in the cab.

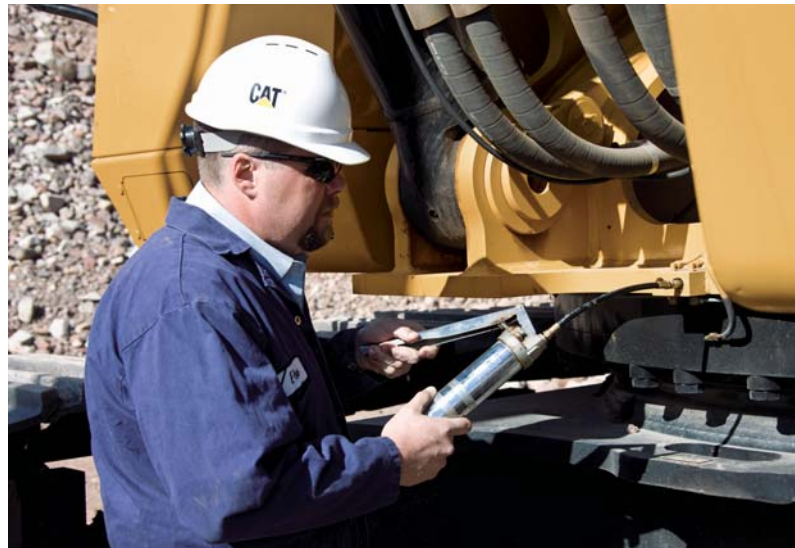

Complete Customer Support

Cat® dealer services to help you operate longer with lower costs



Product Support

Cat dealers utilize a worldwide parts network to minimize machine downtime. Plus you can save money with Cat remanufactured components.

Machine Selection

Make detailed comparisons of machines you are considering. What are the job requirements and machine attachments? What production is needed? Your Cat dealer can provide recommendations.

Purchase

Consider financing options and day-to-day operating costs. Look at dealer services that can be included in the machine's cost to yield lower owning and operating costs over time.

Customer Support Agreements

Cat dealers offer a variety of customer support agreements and work with you to develop a plan to meet specific needs. These plans can cover the entire machine, including attachments, to help protect your investment.

Operation

Improving operating techniques can boost your profits. Your Cat dealer has videos, literature and other ideas to help you increase productivity. Caterpillar also offers simulators and certified operator training to help maximize the return on your investment.

Replacement

Repair, rebuild or replace? Your Cat dealer can help you evaluate the cost involved so you can make the right choice.

390D L Hydraulic Excavator Specifications

Engine

Engine Model	Cat® C18 ACERT™ (ATAAC)	
Net Power – ISO 9249	390 kW	523 hp
Net Power – SAE J1349	390 kW	523 hp
Net Power – EEC 80/1269	390 kW	523 hp
Bore	145 mm	5.71 in
Stroke	183 mm	7.2 in
Displacement	18.1 L	1,104.5 in ³

- The 390D L meets worldwide Tier 3 emission requirements.
- No engine power derating required below 2300 m (7,500 ft) altitude.
- Net power advertised is the power available at the flywheel when the engine is equipped with fan, air cleaner, muffler and alternator.

Weights

Operating Weight – Long Undercarriage	86 190 kg	190,016 lb
---------------------------------------	-----------	------------

• 8.4 m (27.5 ft) GP boom, R4.4 m (14.4 ft) stick, 4.6 m³ (6.0 yd³) HD bucket and 650 mm (26 in) shoes.

Track

Number of Shoes Each Side – Long Undercarriage	51
Number of Track Rollers Each Side – Long Undercarriage	9
Number of Carrier Rollers Each Side	3

Swing Mechanism

Swing Speed	6.2 rpm
Swing Torque	260 kN·m 191,766 lb ft

Drive

Maximum Travel Speed	4.5 km/h	2.8 mph
Maximum Drawbar Pull	590 kN	132,637 lb

Hydraulic System

Main System – Maximum Flow (Total)	980 L/min	258.89 gal/min
Swing System – Maximum Flow	460 L/min	121.52 gal/min
Maximum Pressure – Equipment – Normal	35 000 kPa	5,076.3 psi
Maximum Pressure – Travel	35 000 kPa	5,076.3 psi
Maximum Pressure – Swing	26 000 kPa	3,770.9 psi
Pilot System – Maximum Flow	90 L/min	23.78 gal/min
Pilot System – Maximum Pressure	4120 kPa	597.56 psi
Boom Cylinder – Bore	210 mm	8.27 in
Boom Cylinder – Stroke	1967 mm	77.44 in
Stick Cylinder – Bore	220 mm	8.66 in
Stick Cylinder – Stroke	2262 mm	89.05 in
HB2 Family Bucket Cylinder – Bore	200 mm	7.87 in
HB2 Family Bucket Cylinder – Stroke	1451 mm	57.13 in
JC Family Bucket Cylinder – Bore	220 mm	8.66 in
JC Family Bucket Cylinder – Stroke	1586 mm	62.44 in

Service Refill Capacities

Fuel Tank Capacity	1240 L	327.57 gal
Cooling System	101 L	26.68 gal
Engine Oil	65 L	17.17 gal
Swing Drive (each)	19 L	5.02 gal
Final Drive (each)	21 L	5.55 gal
Hydraulic System (including tank)	995 L	262.85 gal

Sound Performance

Performance	ANSI/SAE J1166 OCT98
-------------	----------------------

- When properly installed and maintained, the cab offered by Caterpillar, when tested with doors and windows closed according to ANSI/SAE J1166 OCT98, meets OSHA and MSHA requirements for operator sound exposure limits in effect at time of manufacture.
- Hearing protection may be needed when operating with an open operator station and cab (when not properly maintained or doors/windows open) for extended periods or in a noisy environment.

Standards

Brakes	SAE J1026 APR90
Cab/FOGS	SAE J1356 FEB88/ISO 10262

390D L Hydraulic Excavator Specifications

Dimensions

All dimensions are approximate

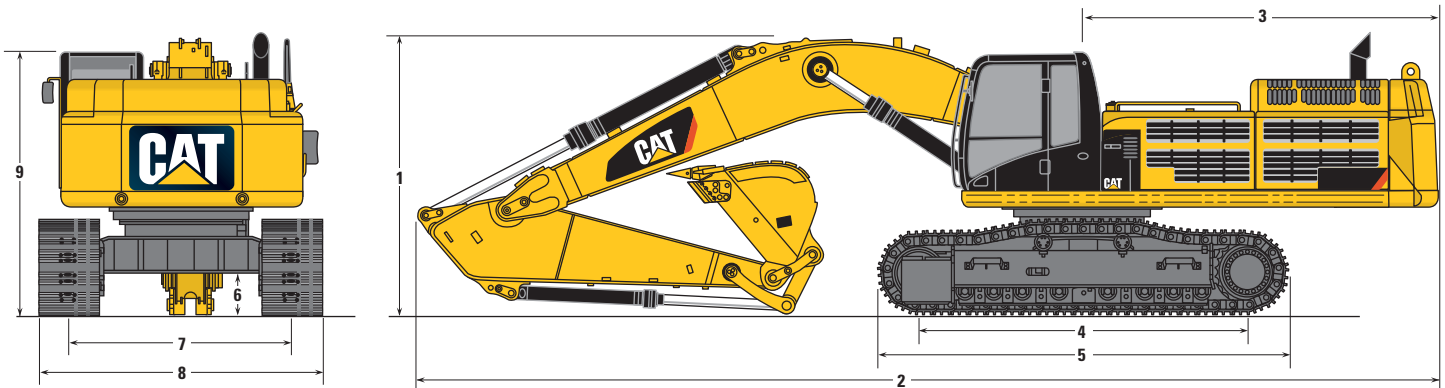

		Reach Boom 10.0 m (32'10")		General Purpose Boom 8.4 m (27'7")			Mass Boom 7.25 m (23'9")			
		R5.5 m (18'1")	R4.4 m (14'5")	R5.5 m (18'1")	R4.4 m (14'5")	GP3.7 m (12'2")	GP3.4 m (11'2")	GP2.92 m (9'7")	M3.4 m (11'2")	M2.92 m (9'7")
Stick	Bucket	HB3.9 m ³ (5.1 yd ³)	HB3.9 m ³ (5.1 yd ³)	HB4.6 m ³ (6.0 yd ³)	HB4.6 m ³ (6.0 yd ³)	HB4.6 m ³ (6.0 yd ³)	JC4.6 m ³ (6.0 yd ³)	JC4.6 m ³ (6.0 yd ³)	JC6.0 m ³ (7.8 yd ³)	JC6.0 m ³ (7.8 yd ³)
1 Shipping Height	mm	5430	5030	5840	5290	5010	5160	4970	5310	4900
	ft	17.81	16.50	19.16	17.35	16.43	16.92	16.30	17.42	16.07
2 Shipping Length	mm	16 280	16 320	14 490	14 700	14 710	14 720	14 910	13 560	13 690
	ft	53.41	53.54	47.53	48.22	46.48	48.29	48.91	44.48	44.91
3 Tail Swing Radius	mm	4680	4680	4680	4680	4680	4680	4680	4680	4680
	ft	15.35	15.35	15.35	15.35	15.35	15.35	15.35	15.35	15.35
4 Length to Center of Rollers***	mm	5120	5120	5120	5120	5120	5120	5120	5120	5120
	ft	16.79	16.79	16.79	16.79	16.79	16.79	16.79	16.79	16.79
5 Track Length****	mm	6360	6360	6360	6360	6360	6360	6360	6360	6360
	ft	20.86	20.86	20.86	20.86	20.86	20.86	20.86	20.86	20.86
6 Ground Clearance	mm	900	900	900	900	900	900	900	900	900
	ft	2.95	2.95	2.95	2.95	2.95	2.95	2.95	2.95	2.95
7 Track Gauge (Shipping)*	mm	2750	2750	2750	2750	2750	2750	2750	2750	2750
	ft	9.02	9.02	9.02	9.02	9.02	9.02	9.02	9.02	9.02
8 Transport Width**	mm	4260	4260	4260	4260	4260	4260	4260	4260	4260
	ft	13.97	13.97	13.97	13.97	13.97	13.97	13.97	13.97	13.97
		(LC)	(LC)	(LC)	(LC)	(LC)	(LC)	(LC)	(LC)	(LC)
9 Cab Height	mm	3760	3760	3760	3760	3760	3760	3760	3760	3760
	ft	12.33	12.33	12.33	12.33	12.33	12.33	12.33	12.33	12.33

* Track gauge in extended (working) position: 3510 mm (11.51 ft).

** Transport width shown for 750 mm (30 in).

Add 150 mm (6 in) for 900 mm (36 in) shoes.

Subtract 100 mm (4 in) for 650 mm (26 in) shoes.

*** STD 4600 mm (15.09 ft) (STD), 5120 mm (16.79 ft) (LC).

**** STD 5840 mm (19.16 ft) (STD), 6360 mm (20.86 ft) (LC).

Working Ranges

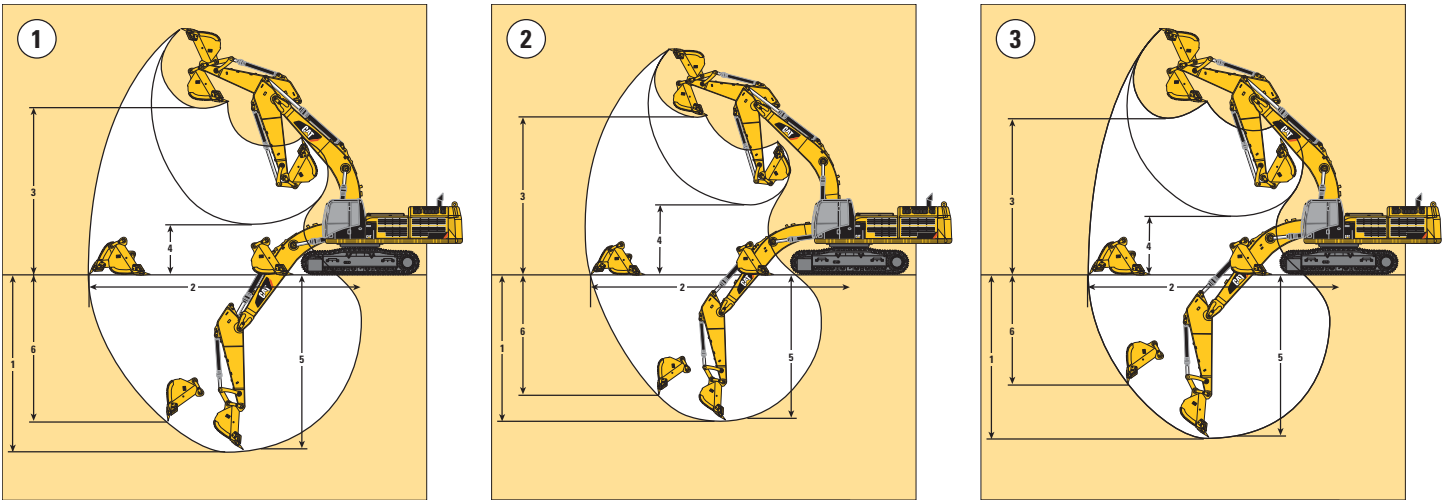

		① Reach Boom 10.0 m (32'10")		② General Purpose Boom 8.4 m (27'7")			③ Mass Boom 7.25 m (23'9")			
Stick		R5.5 m (18'1")	R4.4 m (14'5")	R5.5 m (18'1")	R4.4 m (14'5")	GP3.7 m (12'2")	GP3.4 m (11'2")	GP2.92 m (9'7")	M3.4 m (11'2")	M2.92 m (9'7")
Bucket		HB3.9 m ³ (5.1 yd ³)	HB3.9 m ³ (5.1 yd ³)	HB4.6 m ³ (6.0 yd ³)	HB4.6 m ³ (6.0 yd ³)	HB4.6 m ³ (6.0 yd ³)	JC4.6 m ³ (6.0 yd ³)	JC4.6 m ³ (6.0 yd ³)	JC6.0 m ³ (7.8 yd ³)	JC6.0 m ³ (7.8 yd ³)
1 Maximum Digging Depth	mm	11 810	10 710	10 760	9660	8960	8690	8220	7650	7170
	ft	38.74	35.13	35.30	31.69	29.39	28.51	26.96	25.09	23.52
2 Maximum Reach at Ground Line	mm	17 250	16 230	15 730	14 690	14 040	13 910	13 480	12 690	12 240
	ft	56.59	53.24	51.60	48.19	46.06	45.63	44.22	41.63	40.15
3 Maximum Loading Height	mm	10 950	10 520	9720	9270	8980	9090	8910	8200	7980
	ft	35.92	34.51	31.88	30.41	29.46	29.82	29.23	26.90	26.18
4 Minimum Loading Height	mm	3310	4410	1940	3040	3740	4020	4480	3200	3670
	ft	10.85	14.46	6.36	9.97	12.27	13.18	14.69	10.49	12.04
5 Maximum Depth Cut for 2240 mm (8 ft) Level Bottom	mm	11 710	10 600	10 660	9550	8840	8560	8080	7520	7030
	ft	38.41	34.77	34.97	31.33	29.00	28.08	26.50	24.67	23.06
6 Maximum Vertical Wall Digging Depth	mm	8390	7380	7860	6850	5940	6190	5950	5100	4700
	ft	27.52	24.21	25.78	22.47	19.48	20.30	19.52	16.73	15.41
Bucket Digging Force										
(SAE)	kN	322	321	322	321	321	412	411	404	404
	lb	72,450	72,225	72,450	72,225	72,225	92,700	92,475	90,900	90,900
(ISO)	kN	365	363	365	363	363	471	470	471	470
	lb	82,125	81,675	82,125	81,675	81,675	105,975	105,750	105,975	105,750
Stick Digging Force										
(SAE)	kN	230	268	230	268	300	315	337	314	342
	lb	51,750	60,300	51,750	60,300	67,500	70,875	75,285	70,650	76,950
(ISO)	kN	236	276	236	276	310	325	350	325	356
	lb	53,100	62,100	53,100	62,100	69,750	73,125	78,750	73,125	80,100

390D L Hydraulic Excavator Specifications

Operating Weight* and Ground Pressure

	Track					
	900 mm (36 in) Shoes		750 mm (30 in) Shoes		650 mm (26 in) Shoes	
	kg (lb)	kPa (psi)	kg (lb)	kPa (psi)	kg (lb)	kPa (psi)
Reach Boom – 10.0 m (32'10")						
Bucket – 3.9 m ³ (5.1 yd ³)						
R5.5 m (18'1")	90 070 (198,604)	88.3 (12.8)	88 950 (196,135)	104.7 (15.2)	88 080 (194,216)	119.6 (17.3)
R4.4 m (14'5")	89 570 (197,502)	87.8 (12.7)	88 450 (195,032)	104.1 (15.1)	87 580 (193,114)	118.9 (17.2)
General Purpose Boom – 8.4 m (27'7")						
Bucket – 4.6 m ³ (6.0 yd ³)						
R5.5 m (18'1")	88 690 (195,561)	87.0 (12.6)	87 570 (193,092)	103.1 (14.9)	86 690 (191,151)	117.7 (17.1)
R4.4 m (14'5")	88 180 (194,437)	86.5 (12.5)	87 070 (191,989)	102.5 (14.9)	86 190 (190,049)	117.1 (16.9)
GP3.4 m (11'2")	91 050 (200,765)	89.3 (12.9)	89 930 (198,296)	105.8 (15.3)	89 060 (196,377)	120.9 (17.5)
GP2.92 m (9'7")	90 680 (199,949)	88.9 (12.9)	89 570 (197,502)	105.4 (15.3)	88 690 (195,561)	120.4 (17.5)
Mass Boom – 7.25 m (23'9")						
Bucket – 6.0 m ³ (7.8 yd ³)						
M3.4 m (11'2")	92 380 (203,698)	90.6 (13.1)	91 260 (201,228)	107.4 (15.6)	90 390 (199,310)	122.7 (17.8)
M2.92 m (9'7")	92 130 (203,147)	90.4 (13.1)	91 010 (200,677)	107.1 (15.5)	90 140 (198,759)	122.4 (17.7)

* Operating weight includes full fuel tank and 75 kg (165 lb) operator.

Major Component Weights

	kg	lb
Base machine with counterweight and 750 mm (30 in) shoes (without front linkage)	67 950	149,830
Two boom cylinders	1720	3,793
Counterweight – GP		
Removal type	12 410	27,364
Non-removal type	12 410	27,364
Boom (includes lines, pins, stick cylinder)		
Reach Boom – 10.0 m (32'10")	9750	21,499
General Purpose Boom – 8.4 m (27'7")	8310	18,324
Mass Boom – 7.25 m (23'9")	8480	18,698
Stick (includes lines, pins, bucket cylinder and linkage)		
R5.5 m (18'1")	5430	11,973
R4.4 m (14'5")	4930	10,871
GP3.4 m (11'2")	5270	11,620
GP2.92 m (9'7")	4910	10,827
M3.4 m (11'2")	5420	11,951
M2.92 m (9'7")	5170	11,399

390D L Hydraulic Excavator Specifications

390D L Reach Boom Lift Capacities – Americas



Load Point Height



Load at Maximum Reach



Load Radius Over Front



Load Radius Over Side

Boom – 10.0 m (32 ft 10 in)

Coupler – N/A

Bucket – None

Stick – R5.5 m (18 ft 1 in)

Shoes – 900 mm (36 in) double grouser

Load Point Height	3.0 m/10.0 ft		4.5 m/15.0 ft		6.0 m/20.0 ft		7.5 m/25.0 ft		9.0 m/30.0 ft		10.5 m/35.0 ft		12.0 m/40.0 ft		13.5 m/45.0 ft		15.0 m/50.0 ft		Load at Maximum Reach		m ft	
	kg	lb	kg	lb	kg	lb	kg	lb	kg	lb	kg	lb	kg	lb	kg	lb	kg	lb	kg	lb		
12.0 m 40.0 ft																				*9750	*9750	11.82
																				*21,600	*21,600	38.26
10.5 m 35.0 ft													*12 200	*12 200						*9400	*9400	12.87
													*25,350	*25,350						*20,800	*20,800	41.87
9.0 m 30.0 ft												*13 700	*13 700	*12 900	12 500	*10 150	9950			*9250	*9250	13.67
												*29,850	*29,850	*28,200	26,800					*20,450	*20,450	44.63
7.5 m 25.0 ft												*14 400	*14 400	*13 300	12 200	*12 500	9800			*9250	8750	14.27
												*31,250	*31,250	*28,950	26,200	*25,750	21,000			*20,400	19,450	46.68
6.0 m 20.0 ft							*20 250	*20 250	*17 250	*17 250	*15 250	14 700	*13 850	11 800	*12 800	9600				*9400	8150	14.69
							*43,650	*43,650	*37,350	*37,350	*33,100	31,650	*30,050	25,350	*27,850	20,500				*20,650	18,000	48.12
4.5 m 15.0 ft					*29 300	*29 300	*22 600	*22 600	*18 750	17 700	*16 200	14 000	*14 450	11 350	*13 150	9300				*9650	7700	14.94
					*62,850	*62,850	*48,750	*48,750	*40,500	38,200	*35,100	30,200	*31,300	24,350	*28,500	19,950				*21,200	17,000	49.00
3.0 m 10.0 ft					*20 200	*20 200	*24 700	21 550	*20 100	16 700	*17 100	13 350	*15 000	10 900	*13 450	9000	*10 400	7500		*10 050	7450	15.04
					*49,750	*49,750	*53,300	46,550	*43,450	36,000	*37,050	28,700	*32,550	23,400	*29,200	19,300				*22,100	16,400	49.35
1.5 m 5.0 ft					*15 750	*15 750	*26 100	20 300	*21 150	15 800	*17 850	12 750	*15 500	10 450	13 400	8700				*10 600	7350	14.99
					*37,450	*37,450	*56,450	43,800	*45,700	34,100	*38,600	27,400	*33,550	22,500	28,800	18,700				*23,300	16,150	49.19
Ground Line					*17 000	*17 000	*26 700	19 500	*21 700	15 200	*18 250	12 250	15 650	10 100	13 150	8500				*11 350	7350	14.78
					*39,600	*39,600	*57,800	42,050	*47,000	32,700	*39,550	26,400	33,650	21,750	28,300	18,250				*25,000	16,200	48.51
-1.5 m -5.0 ft			*11 350	*11 350	*20 750	*20 750	*26 550	19 050	*21 800	14 750	*18 350	11 950	15 400	9900	13 000	8350				11 850	7600	14.42
			*25,900	*25,900	*47,750	*47,750	*57,500	41,050	*47,150	31,800	*39,650	25,700	33,100	21,250	27,950	17,900				26,100	16,700	47.28
-3.0 m -10.0 ft	*12 300	*12 300	*16 800	*16 800	*26 150	*26 150	*25 700	18 900	*21 300	14 550	*17 950	11 750	15 250	9750	12 950	8300				*12 350	8000	13.88
	*27,700	*27,700	*38,150	*38,150	*59,950	57,000	*55,700	40,700	*46,100	31,400	*38,800	25,300	32,850	21,000	*27,750	17,850				*27,250	17,600	45.46
-4.5 m -15.0 ft	*17 900	*17 900	*23 000	*23 000	*29 200	26 750	*24 150	18 950	*20 200	14 550	*17 050	11 750	*14 350	9750						*12 300	8700	13.14
	*40,300	*40,300	*52,100	*52,100	*63,300	57,500	*52,250	40,850	*43,650	31,350	*36,700	25,250	*30,750	21,050						*27,050	19,200	42.98
-6.0 m -20.0 ft	*24 100	*24 100	*30 400	*30 400	*26 050	*26 050	*21 850	19 200	*18 350	14 750	*15 350	11 900	*12 400	9950						*12 000	9800	12.18
	*54,400	*54,400	*67,350	*67,350	*56,200	*56,200	*47,050	41,400	*39,450	31,750	*32,800	25,650								*26,400	21,800	39.71
-7.5 m -25.0 ft			*25 300	*25 300	*21 700	*21 700	*18 450	*18 450	*15 400	15 100	*12 350	12 300								*11 350	*11 350	10.91
			*54,200	*54,200	*46,450	*46,450	*39,350	*39,350	*32,650	*32,650	*25,600	*25,600								*24,850	*24,850	35.43
-9.0 m -30.0 ft					*15 650	*15 650	*13 300	*13 300	*10 400	*10 400										*9800	*9800	9.24
							*27,500	*27,500												*21,100	*21,100	29.68

*Indicates that the load is limited by hydraulic lifting capacity rather than tipping load. The above loads are in compliance with hydraulic excavator lift capacity standard ISO 10567:2007. They do not exceed 87% of hydraulic lifting capacity or 75% of tipping load. Weight of all lifting accessories must be deducted from the above lifting capacities. Lifting capacities are based on the machine standing on a firm, uniform supporting surface.

Always refer to the appropriate Operation and Maintenance Manual for specific product information.

390D L Reach Boom Lift Capacities – Americas



Load Point Height



Load at Maximum Reach



Load Radius Over Front



Load Radius Over Side

Boom – 10.0 m (32 ft 10 in)

Coupler – N/A

Bucket – None

Stick – R4.4 m (14 ft 5 in)

Shoes – 900 mm (36 in) double grouser

Load Point Height	3.0 m/10.0 ft		4.5 m/15.0 ft		6.0 m/20.0 ft		7.5 m/25.0 ft		9.0 m/30.0 ft		10.5 m/35.0 ft		12.0 m/40.0 ft		13.5 m/45.0 ft		Load at Maximum Reach		m ft	
	kg lb	kg lb	kg lb	kg lb	kg lb	kg lb	kg lb	kg lb	kg lb	kg lb	kg lb	kg lb	kg lb	kg lb	kg lb	kg lb	kg lb	kg lb		
12.0 m 40.0 ft												*12 950 *12 950						*12 950 *28,750	*12 950 *28,750	10.50 33.88
10.5 m 35.0 ft												*14 550 *31,850	*14 550 *31,850					*12 450 *27,500	*12 450 *27,500	11.67 37.92
9.0 m 30.0 ft												*14 850 *32,300	*14 850 *32,300	*13 950 *30,500	12 000 25,600			*12 250 *26,950	10 950 24,450	12.55 40.94
7.5 m 25.0 ft									*17 250 *37,300	*17 250 *37,300	*15 450 *33,500	14 750 31,800	*14 150 *30,850	11 750 25,200				*12 250 *26,950	9800 21,750	13.20 43.17
6.0 m 20.0 ft					*28 250 *60,550	*28 250 *60,550	*22 100 *47,550	*22 100 *47,550	*18 500 *40,050	18 000 38,850	*16 200 *35,100	14 150 30,500	*14 600 *31,700	11 400 24,450	*13 450 *29,450	9250		*12 450 *27,350	9050 19,950	13.66 44.73
4.5 m 15.0 ft							*24 250 *52,250	21 950 47,500	*19 850 *42,850	17 000 36,650	*17 000 *36,850	13 550 29,150	*15 050 *32,700	11 000 23,600	*13 650 *29,450	9000 19,300		*12 800 *28,150	8500 18,800	13.93 45.67
3.0 m 10.0 ft							*25 900 *55,900	20 550 44,400	*20 950 *45,300	16 050 34,700	*17 750 *38,400	12 900 27,850	*15 500 *33,600	10 600 22,800	13 450 28,950	8800 18,850		12 650 27,850	8200 18,100	14.04 46.05
1.5 m 5.0 ft							*26 700 *57,750	19 600 42,350	*21 650 *46,850	15 350 33,150	*18 250 *39,500	12 400 26,750	15 750 33,950	10 250 22,050	13 250 28,450	8550 18,400		12 550 27,650	8100 17,850	13.98 45.88
Ground Line					*13 200 *31,400	*13 200 *31,400	*26 650 *57,700	19 100 41,200	*21 850 *47,300	14 900 32,100	*18 400 *39,850	12 050 25,950	15 500 33,350	10 000 21,500	13 100 28,150	8400 18,100		12 750 28,050	8200 18,000	13.76 45.14
-1.5 m -5.0 ft					*20 100 *46,550	*20 100 *46,550	*25 850 *56,100	18 950 40,750	*21 500 *46,550	14 650 31,500	*18 150 *39,300	11 800 25,450	15 350 33,000	9850 21,150				13 200 29,100	8500 18,700	13.36 43.82
-3.0 m -10.0 ft			*17 950 *40,950	*17 950 *40,950	*28 350 *63,000	26 800 57,600	*24 450 *53,050	18 950 40,800	*20 600 *44,500	14 550 31,400	*17 400 *37,550	11 750 25,350	*14 700 *31,500	9800 21,150				*13 200 *29,100	9050 20,000	12.78 41.85
-4.5 m -15.0 ft			*26 800 *60,950	*26 800 *60,950	*26 100 *56,700	*26 100 *56,700	*22 350 *48,350	19 200 41,300	*18 950 *40,850	14 700 31,700	*15 950 *34,200	11 850 25,600						*12 950 *28,500	10 000 22,200	11.98 39.14
-6.0 m -20.0 ft			*24 850 *53,750	*24 850 *53,750	*22 350 *48,150	*22 350 *48,150	*19 350 *41,600	*19 350 *41,600	*16 400 *35,000	15 050 32,450	*13 300 *27,900	12 200 26,450						*12 350 *27,000	11 650 26,000	10.90 35.51
-7.5 m -25.0 ft					*17 100 *36,250	*17 100 *36,250	*14 900 *31,400	*14 900 *31,400	*12 100 *24,800	*12 100 *24,800								*10 950 *23,700	*10 950 *23,700	9.47 30.63

*Indicates that the load is limited by hydraulic lifting capacity rather than tipping load. The above loads are in compliance with hydraulic excavator lift capacity standard ISO 10567:2007. They do not exceed 87% of hydraulic lifting capacity or 75% of tipping load. Weight of all lifting accessories must be deducted from the above lifting capacities. Lifting capacities are based on the machine standing on a firm, uniform supporting surface.

Always refer to the appropriate Operation and Maintenance Manual for specific product information.

390D L Hydraulic Excavator Specifications

390D L General Purpose Boom Lift Capacities – Americas



Load Point Height



Load at Maximum Reach



Load Radius Over Front



Load Radius Over Side

Boom – 8.4 m (27 ft 7 in)

Coupler – N/A

Bucket – None

Stick – R5.5 m (18 ft 1 in)

Shoes – 900 mm (36 in) double grouser

Load Point Height	3.0 m/10.0 ft		4.5 m/15.0 ft		6.0 m/20.0 ft		7.5 m/25.0 ft		9.0 m/30.0 ft		10.5 m/35.0 ft		12.0 m/40.0 ft		13.5 m/45.0 ft		Load at Maximum Reach		m ft	
	kg lb	kg lb	kg lb	kg lb	kg lb	kg lb	kg lb	kg lb	kg lb	kg lb	kg lb	kg lb	kg lb	kg lb	kg lb	kg lb	kg lb	kg lb		
12.0 m 40.0 ft																		*9050 *20,200	*9050 *20,200	9.83 31.62
10.5 m 35.0 ft											*10 950 *21,900	*10 950 *21,900						*8500 *18,800	*8500 *18,800	11.07 35.92
9.0 m 30.0 ft											*13 000 *27,750	*13 000 *27,750						*8200 *18,050	*8200 *18,050	12.00 39.10
7.5 m 25.0 ft											*14 450 *31,150	*14 450 *31,150	*11 500 *23,250	*11 500 *23,250				*8050 *17,750	*8050 *17,750	12.68 41.43
6.0 m 20.0 ft									*17 550 *38,050	*17 550 *38,050	*16 200 *35,100	15 450 33,250	*13 500 *28,200	12 350 26,450				*8100 *17,800	*8100 *17,800	13.15 43.05
4.5 m 15.0 ft					*27 100 *58,300	*27 100 *58,300	*22 200 *48,000	*22 200 *48,000	*19 200 *41,600	19 050 41,000	*17 150 *37,300	14 950 32,150	*15 400 *32,400	12 050 25,850				*8250 *18,150	*8250 *18,150	13.43 44.03
3.0 m 10.0 ft					*31 500 *67,950	*31 500 *67,950	*24 800 *53,650	23 850 51,450	*20 800 *45,100	18 200 39,250	*18 200 *39,450	14 400 31,050	*16 300 *35,450	11 700 25,150	*9000	*9000		*8600 *18,850	*8600 *18,850	13.54 44.43
1.5 m 5.0 ft					*34 800 *75,200	31 350 67,550	*26 950 *58,300	22 650 48,850	*22 200 *48,100	17 450 37,550	*19 050 *41,350	13 900 29,950	*16 800 *36,400	11 400 24,450				*9050 *19,900	*9050 *19,900	13.48 44.25
Ground Line			*19 000 *43,500	*19 000 *43,500	*36 450 *78,950	30 100 64,750	*28 300 *61,300	21 800 46,900	*23 150 *50,150	16 850 36,250	*19 650 *42,550	13 500 29,050	16 650 35,800	11 100 23,900				*9750 *21,450	9600 21,100	13.25 43.49
-1.5 m -5.0 ft		*14 250 *31,950	*14 250 *31,950	*23 200 *52,800	*23 200 *52,800	*36 600 *79,250	29 450 63,300	*28 750 *62,200	21 200 45,700	*23 500 *50,850	16 400 35,300	*19 750 *42,750	13 200 28,450	16 450 35,400	10 950 23,550			*10 700 *23,650	9950 21,900	12.84 42.11
-3.0 m -10.0 ft		*20 200 *45,350	*20 200 *45,350	*29 400 *66,800	*29 400 *66,800	*35 350 *76,600	29 200 62,800	*28 150 *60,900	20 950 45,100	*23 050 *49,850	16 200 34,850	*19 250 *41,500	13 050 28,150	*15 550 *27,550	10 900 23,500			*12 200 *26,950	10 650 23,450	12.23 40.06
-4.5 m -15.0 ft		*27 050 *60,950	*27 050 *60,950	*37 750 *85,900	*37 750 *85,900	*32 850 *70,950	29 300 63,000	*26 400 *57,000	20 950 45,100	*21 650 *46,550	16 150 34,850	*17 700 *37,750	13 100 28,250				*14 500 *32,200	11 800 26,150	11.39 37.21	
-6.0 m -20.0 ft		*35 550 *80,450	*35 550 *80,450	*35 950 *77,350	*35 950 *77,350	*28 700 *61,650	*28 700 *61,650	*23 250 *49,750	21 200 45,700	*18 750 *39,750	16 400 35,400						*14 900 *32,650	13 850 30,850	10.26 33.37	
-7.5 m -25.0 ft				*27 300 *57,700	*27 300 *57,700	*22 250 *46,900	*22 250 *46,900	*17 700 *36,800	*17 700 *36,800								*13 650 *29,750	*13 650 *29,750	8.71 28.11	

*Indicates that the load is limited by hydraulic lifting capacity rather than tipping load. The above loads are in compliance with hydraulic excavator lift capacity standard ISO 10567:2007. They do not exceed 87% of hydraulic lifting capacity or 75% of tipping load. Weight of all lifting accessories must be deducted from the above lifting capacities. Lifting capacities are based on the machine standing on a firm, uniform supporting surface.

Always refer to the appropriate Operation and Maintenance Manual for specific product information.

390D L General Purpose Boom Lift Capacities – Americas



Load Point Height



Load at Maximum Reach



Load Radius Over Front



Load Radius Over Side

Boom – 8.4 m (27 ft 7 in)

Coupler – N/A

Bucket – None

Stick – R4.4 m (14 ft 5 in)

Shoes – 900 mm (36 in) double grouser

 Load Point Height m ft	3.0 m/10.0 ft		4.5 m/15.0 ft		6.0 m/20.0 ft		7.5 m/25.0 ft		9.0 m/30.0 ft		10.5 m/35.0 ft		12.0 m/40.0 ft		 Load at Maximum Reach m ft			
	kg lb	kg lb	kg lb	kg lb	kg lb	kg lb	kg lb	kg lb	kg lb	kg lb	kg lb	kg lb	kg lb	kg lb	kg lb	kg lb	m ft	
10.5 m 35.0 ft										*15 350 *31,700	*15 350 *31,700					*11 350 *25,200	*11 350 *25,200	9.79 31.65
9.0 m 30.0 ft										*17 350 *37,950	*17 350 *37,950	*13 350 *29,400	*13 350 *29,400			*10 900 *24,050	*10 900 *24,050	10.82 35.23
7.5 m 25.0 ft										*18 050 *39,350	*18 050 *39,350	*16 900 *37,100	15 300 32,900			*10 700 *23,600	*10 700 *23,600	11.57 37.80
6.0 m 20.0 ft							*21 900 *47,350	*21 900 *47,350	*19 250 *41,800	19 200 41,300	*17 500 *38,100	14 950 32,200	*11 750 *25,800	*11 750 *25,800	*10 750 *23,700	*10 750 *23,700	12.09 39.57	
4.5 m 15.0 ft					*30 450 *65,550	*30 450 *65,550	*24 300 *52,450	24 250 52,300	*20 650 *44,750	18 450 39,700	*18 250 *39,700	14 550 31,250	*15 150 *29,200	11 700 25,100	*11 050 *24,250	*11 050 *24,250	12.40 40.64	
3.0 m 10.0 ft					*34 200 *73,750	31 750 68,550	*26 500 *57,300	23 000 49,650	*22 000 *47,650	17 650 38,100	*19 050 *41,350	14 050 30,250	*16 950 *34,000	11 450 24,550	*11 500 *25,300	10 700 23,550	12.52 41.07	
1.5 m 5.0 ft					*36 300 *78,500	30 250 65,250	*28 100 *60,750	22 000 47,450	*23 050 *49,850	17 000 36,700	*19 650 *42,600	13 650 29,350	16 750 *35,250	11 200 24,100	*12 200 *26,850	10 600 23,300	12.46 40.87	
Ground Line					*36 650 *79,450	29 500 63,500	*28 750 *62,250	21 350 46,000	*23 500 *50,950	16 550 35,650	*19 850 *43,000	13 300 28,700	16 550 *29,800	11 050 23,750	*13 300 *29,250	10 750 23,700	12.21 40.05	
-1.5 m -5.0 ft			*24 000 *54,600	*24 000 *54,600	*35 650 *77,300	29 200 62,800	*28 400 *61,550	21 000 45,250	*23 300 *50,450	16 250 35,050	*19 500 *42,050	13 150 28,300			*14 850 *32,800	11 300 24,900	11.76 38.54	
-3.0 m -10.0 ft		*23 450 *52,700	*23 450 *52,700	*33 350 *75,900	*33 350 *75,900	*33 350 *72,300	29 250 62,900	*27 000 *58,400	20 950 45,100	*22 200 *47,850	16 200 34,900	*18 150 *38,900	13 150 28,350		*16 500 *36,350	12 250 27,100	11.09 36.29	
-4.5 m -15.0 ft		*33 050 *74,550	*33 050 *74,550	*36 400 *78,800	*36 400 *78,800	*29 700 *64,150	29 600 63,650	*24 300 *52,300	21 150 45,550	*19 700 *42,150	16 350 35,350				*16 150 *35,500	14 000 31,100	10.15 33.11	
-6.0 m -20.0 ft				*28 900 *61,900	*28 900 *61,900	*24 100 *51,450	*24 100 *51,450	*19 550 *41,400	*19 550 *41,400						*15 050 *32,900	*15 050 *32,900	8.85 28.71	

*Indicates that the load is limited by hydraulic lifting capacity rather than tipping load. The above loads are in compliance with hydraulic excavator lift capacity standard ISO 10567:2007. They do not exceed 87% of hydraulic lifting capacity or 75% of tipping load. Weight of all lifting accessories must be deducted from the above lifting capacities. Lifting capacities are based on the machine standing on a firm, uniform supporting surface.

Always refer to the appropriate Operation and Maintenance Manual for specific product information.

390D L Hydraulic Excavator Specifications

390D L General Purpose Boom Lift Capacities – Americas



Load Point Height



Load at Maximum Reach



Load Radius Over Front



Load Radius Over Side

















Boom – 8.4 m (27 ft 7 in)

Coupler – N/A

Bucket – None

Stick – GP3.4 m (11 ft 2 in)

Shoes – 900 mm (36 in) double grouser

	3.0 m/10.0 ft		4.5 m/15.0 ft		6.0 m/20.0 ft		7.5 m/25.0 ft		9.0 m/30.0 ft		10.5 m/35.0 ft				m ft		
																	
10.5 m 35.0 ft	kg lb														*15 550 *34,550	*15 550 *34,550	8.73 28.12
9.0 m 30.0 ft	kg lb								*19 000 *41,700	*19 000 *41,700					*14 600 *32,300	*14 600 *32,300	9.88 32.11
7.5 m 25.0 ft	kg lb							*21 700 *47,050	*21 700 *47,050	*19 500 *42,450	19 150 41,200	*17 150 14 750			*14 200 *31,300	*14 200 *31,300	10.70 34.92
6.0 m 20.0 ft	kg lb					*29 050 *62,450	*29 050 *62,450	*23 650 *51,150	*23 650 *51,150	*20 500 *44,500	18 550 39,950	*18 500 *40,350	14 500 31,100		*14 150 *31,100	12 850 28,450	11.25 36.83
4.5 m 15.0 ft	kg lb					*33 200 *71,350	32 400 70,000	*25 850 *55,800	23 400 50,500	*21 700 *47,000	17 850 38,500	*19 050 *41,450	14 100 30,350		*14 350 *31,600	12 050 26,550	11.59 37.97
3.0 m 10.0 ft	kg lb							*27 650 *59,800	22 300 48,150	*22 800 *49,300	17 200 37,100	*19 600 *42,550	13 750 29,550		*14 900 *32,750	11 600 25,600	11.72 38.43
1.5 m 5.0 ft	kg lb							*28 650 *62,000	21 550 46,400	*23 450 *50,750	16 700 35,950	*19 900 *43,050	13 400 28,850		*15 800 *34,700	11 550 25,400	11.65 38.22
Ground Line	kg lb					*33 250 *77,850	29 300 63,000	*28 650 *62,050	21 100 45,450	*23 500 *50,850	16 350 35,200	*19 650 *42,500	13 200 28,400		*17 150 *37,750	11 800 26,050	11.38 37.34
-1.5 m -5.0 ft	kg lb			*21 450 *49,500	*21 450 *49,500	*33 850 *73,500	29 300 63,000	*27 600 *59,750	20 950 45,100	*22 700 *49,000	16 200 34,900	*18 600 *39,850	13 150 28,400		*17 400 *38,300	12 550 27,650	10.90 35.72
-3.0 m -10.0 ft	kg lb			*36 000 *78,550	*36 000 *78,550	*30 650 *66,500	29 550 63,500	*25 350 *54,750	21 050 45,350	*20 700 *44,500	16 300 35,150				*16 900 *37,200	13 900 30,800	10.17 33.26
-4.5 m -15.0 ft	kg lb			*30 050 *65,100	*30 050 *65,100	*25 950 *55,900	*25 950 *55,900	*21 450 *45,900	21 450 *45,900	*16 400 *16 400					*15 800 *34,650	*15 800 *34,650	9.13 29.76
-6.0 m -20.0 ft	kg lb					*18 500 *38,900	*18 500 *38,900	*13 950 *13 950							*13 300 *30,850	*13 300 *30,850	7.63 23.96

















Boom – 8.4 m (27 ft 7 in)

Coupler – N/A

Bucket – None

Stick – GP2.92 m (9 ft 7 in)

Shoes – 900 mm (36 in) double grouser

	3.0 m/10.0 ft		4.5 m/15.0 ft		6.0 m/20.0 ft		7.5 m/25.0 ft		9.0 m/30.0 ft		10.5 m/35.0 ft				m ft		
																	
10.5 m 35.0 ft	kg lb							*21 400 *47,300	*21 400 *47,300						*17 650 *39,300	*17 650 *39,300	8.15 26.19
9.0 m 30.0 ft	kg lb							*21 450 *46,800	*21 450 *46,800	*20 050 *41,750	19 250 41,150				*16 450 *36,400	*16 450 *36,400	9.38 30.44
7.5 m 25.0 ft	kg lb							*22 700 *49,200	*22 700 *49,200	*20 300 *44,250	18 950 40,800				*15 900 *35,100	15 200 33,850	10.23 33.39
6.0 m 20.0 ft	kg lb					*30 550 *65,650	*30 550 *65,650	*24 600 *53,150	24 350 52,500	*21 200 *46,000	18 400 39,650	*19 150 *41,050	14 400 30,850		*15 800 *34,800	13 650 30,250	10.81 35.38
4.5 m 15.0 ft	kg lb							*26 650 *57,550	23 150 50,000	*22 300 *48,300	17 750 38,300	*19 550 *42,500	14 050 30,250		*16 050 *35,300	12 750 28,150	11.16 36.58
3.0 m 10.0 ft	kg lb							*28 250 *61,050	22 150 47,850	*23 200 *50,300	17 150 37,000	*19 950 *43,250	13 750 29,550		*16 650 *36,600	12 300 27,100	11.29 37.05
1.5 m 5.0 ft	kg lb							*28 950 *62,650	21 500 46,350	*23 700 *51,300	16 700 35,950	*20 050 *43,350	13 450 28,950		*17 650 *38,800	12 250 26,950	11.22 36.84
Ground Line	kg lb					*30 450 *72,700	29 450 63,350	*28 550 *61,900	21 150 45,600	*23 500 *50,850	16 400 35,350	*19 550 *42,100	13 300 28,650		*18 300 *40,350	12 600 27,750	10.95 35.91
-1.5 m -5.0 ft	kg lb					*32 700 *71,200	29 550 63,500	*27 150 *58,800	21 100 45,450	*22 350 *48,300	16 350 35,200				*18 000 *39,650	13 450 29,650	10.44 34.23
-3.0 m -10.0 ft	kg lb			*32 750 *71,700	*32 750 *71,700	*29 200 *63,400	*29 200 *63,400	*24 450 *52,850	21 300 45,850	*19 850 *42,350	16 500 35,650				*17 300 *38,050	15 100 33,400	9.68 31.66
-4.5 m -15.0 ft	kg lb			*26 750 *57,950	*26 750 *57,950	*23 950 *51,550	*23 950 *51,550	*19 850 *42,200	*19 850 *42,200						*15 750 *34,450	*15 750 *34,450	8.58 27.95

*Indicates that the load is limited by hydraulic lifting capacity rather than tipping load. The above loads are in compliance with hydraulic excavator lift capacity standard ISO 10567:2007. They do not exceed 87% of hydraulic lifting capacity or 75% of tipping load. Weight of all lifting accessories must be deducted from the above lifting capacities. Lifting capacities are based on the machine standing on a firm, uniform supporting surface.

Always refer to the appropriate Operation and Maintenance Manual for specific product information.

390D L Mass Boom Lift Capacities – Americas



Load Point Height



Load at Maximum Reach



Load Radius Over Front



Load Radius Over Side















Boom – 7.25 m (23 ft 9 in)

Coupler – N/A

Bucket – None

Stick – M3.4 m (11 ft 2 in)

Shoes – 900 mm (36 in) double grouser

	3.0 m/10.0 ft		4.5 m/15.0 ft		6.0 m/20.0 ft		7.5 m/25.0 ft		9.0 m/30.0 ft				m ft	
														
10.5 m 35.0 ft	kg lb											*17 400 *38,850	*17 400 *38,850	6.96 22.17
9.0 m 30.0 ft	kg lb							*21 650 *45,800	*21 650 *45,800			*15 900 *35,300	*15 900 *35,300	8.36 27.07
7.5 m 25.0 ft	kg lb							*23 500 *51,150	*23 500 *51,150	*18 950 *37,100	*18 950 *37,100	*15 350 *33,850	*15 350 *33,850	9.32 30.36
6.0 m 20.0 ft	kg lb					*29 350 *63,350	*29 350 *63,350	*24 900 *54,050	*24 900 *54,050	*22 200 *48,350	18 900 40,600	*15 250 *33,600	*15 250 *33,600	9.95 32.55
4.5 m 15.0 ft	kg lb			*45 600 *97,750	*45 600 *97,750	*33 050 *71,300	*33 050 *71,300	*26 800 *58,000	24 350 52,450	*23 000 *50,000	18 350 39,500	*15 600 *34,300	14 700 32,500	10.33 33.84
3.0 m 10.0 ft	kg lb					*36 200 *78,250	32 500 70,000	*28 500 *61,700	23 300 50,250	*23 850 *51,700	17 800 38,300	*16 350 *35,900	14 100 31,100	10.47 34.36
1.5 m 5.0 ft	kg lb					*37 700 *81,550	31 150 67,100	*29 500 *63,850	22 500 48,450	*24 250 *52,500	17 300 37,250	*17 600 *38,650	14 050 30,900	10.40 34.12
Ground Line	kg lb			*27 950 *64,650	*27 950 *64,650	*37 150 *80,500	30 500 65,650	*29 300 *63,500	22 000 47,350	*23 800 *51,450	17 000 36,550	*19 550 *43,100	14 500 31,900	10.10 33.12
-1.5 m -5.0 ft	kg lb	*23 550 *53,150	*23 550 *53,150	*41 700 *94,900	*41 700 *94,900	*34 700 *75,200	30 350 65,250	*27 650 *59,800	21 800 46,900	*22 000 *47,200	16 900 36,450	*19 800 *43,650	15 650 34,500	9.55 31.28
-3.0 m -10.0 ft	kg lb	*38 700 *87,400	*38 700 *87,400	*37 000 *80,250	*37 000 *80,250	*30 150 *65,150	*30 150 *65,150	*24 000 *51,450	21 950 47,300			*18 800 *41,300	17 950 39,750	8.70 28.44
-4.5 m -15.0 ft	kg lb			*27 250 *58,400	*27 250 *58,400	*22 550 *47,850	*22 550 *47,850					*16 350 *35,550	*16 350 *35,550	7.46 24.23















Boom – 7.25 m (23 ft 9 in)

Coupler – N/A

Bucket – None

Stick – M2.92 m (9 ft 7 in)

Shoes – 900 mm (36 in) double grouser

	3.0 m/10.0 ft		4.5 m/15.0 ft		6.0 m/20.0 ft		7.5 m/25.0 ft		9.0 m/30.0 ft				m ft	
														
10.5 m	kg											*20 950	*20 950	6.27
9.0 m 30.0 ft	kg lb							*22 600 *44,200	*22 600 *44,200			*18 950 *42,050	*18 950 *42,050	7.81 25.22
7.5 m 25.0 ft	kg lb							*24 400 *53,250	*24 400 *53,250			*18 200 *40,150	*18 200 *40,150	8.82 28.73
6.0 m 20.0 ft	kg lb			*39 800 *85,300	*39 800 *85,300	*30 550 *66,000	*30 550 *66,000	*25 700 *55,750	24 950 53,700	*22 750 *49,650	18 550 39,850	*18 100 *39,850	16 950 37,550	9.49 31.03
4.5 m 15.0 ft	kg lb					*34 100 *73,500	33 650 72,550	*27 400 *59,300	23 950 51,550	*23 400 *50,850	18 050 38,900	*18 550 *40,800	15 550 34,350	9.89 32.39
3.0 m 10.0 ft	kg lb					*36 800 *79,450	31 850 68,650	*28 850 *62,400	22 950 49,450	*24 000 *52,100	17 550 37,750	*19 500 *42,900	14 850 32,800	10.04 32.93
1.5 m 5.0 ft	kg lb					*37 550 *81,400	30 750 66,200	*29 450 *63,800	22 200 47,850	*24 150 *52,250	17 100 36,850	*21 150 *46,500	14 800 32,600	9.96 32.68
Ground Line	kg lb			*25 950 *60,500	*25 950 *60,500	*36 300 *78,850	30 250 65,100	*28 850 *62,500	21 800 46,950	*23 300 *50,250	16 850 36,350	*20 950 *46,200	15 350 33,800	9.64 31.64
-1.5 m -5.0 ft	kg lb	*54,600	*54,600	*40 350 *88,100	*40 350 *88,100	*33 250 *72,100	30 250 65,000	*26 650 *57,600	21 700 46,750	*20 650	16 900	*20 300 *44,750	16 750 36,950	9.07 29.70
-3.0 m -10.0 ft	kg lb			*33 300 *72,350	*33 300 *72,350	*27 950 *60,350	*27 950 *60,350	*22 050 *46,950	22 000 46,950			*18 850 *41,400	*18 850 *41,400	8.17 26.69
-4.5 m -15.0 ft	kg lb					*18 900 *39,550	*18 900 *39,550					*15 600 *36,200	*15 600 *36,200	6.77 21.22

*Indicates that the load is limited by hydraulic lifting capacity rather than tipping load. The above loads are in compliance with hydraulic excavator lift capacity standard ISO 10567:2007. They do not exceed 87% of hydraulic lifting capacity or 75% of tipping load. Weight of all lifting accessories must be deducted from the above lifting capacities. Lifting capacities are based on the machine standing on a firm, uniform supporting surface.

Always refer to the appropriate Operation and Maintenance Manual for specific product information.

390D L Hydraulic Excavator Specifications

390D L Bucket Specifications and Compatibility – Americas

	Linkage	Width		Capacity		Weight		Fill	Reach Boom		General Purpose Boom					ME Boom	
		mm	in	m ³	yd ³	kg	lb		%	R4.4HB2	R5.5HB2	R4.4HB2	R5.5HB2	G3.7HB2	G2.9JC	G3.4JC	M2.9JC
Without Quick Coupler																	
General Duty (GD)	HB2	1350	54	3.0	4.0	3406	7,507	100%	○	⊗	●	●	●	–	–	–	–
	HB2	1650	66	3.9	5.1	3794	8,362	100%	⊗	⊗	⊙	○	●	–	–	–	–
	HB2	1900	75	4.6	6.0	4155	9,158	100%	⊗	⊗	○	⊗	●	–	–	–	–
	HB2	1100	43	2.2	2.8	2856	6,295	100%	●	⊙	●	●	●	–	–	–	–
	HB2	1350	54	2.9	3.8	3187	7,024	100%	⊙	⊗	●	●	●	–	–	–	–
	HB2	1650	66	3.7	4.9	3650	8,045	100%	⊗	⊗	●	○	●	–	–	–	–
	HB2	1900	75	4.3	5.7	3923	8,646	100%	⊗	⊗	⊙	◇	●	–	–	–	–
	HB2	2000	79	4.6	6.0	4032	8,887	100%	⊗	⊗	○	⊗	●	–	–	–	–
	JC	2300	91	5.7	7.4	5822	12,832	100%	–	–	–	–	–	◇	⊗	●	⊙
	JC	2420	95	6.0	7.9	6004	13,233	100%	–	–	–	–	–	⊗	⊗	⊙	⊙
	JC	2575	101	6.5	8.5	6238	13,749	100%	–	–	–	–	–	⊗	⊗	⊙	◇
General Duty XL (GDXL)	HB2	2000	79	5.3	7.0	4400	9,698	100%	⊗	⊗	⊗	⊗	⊙	–	–	–	–
	HB2	2250	89	6.0	8.0	4796	10,570	100%	⊗	⊗	⊗	⊗	○	–	–	–	–
Heavy Duty (HD)	JC	1750	69	4.1	5.3	4799	10,577	100%	–	–	–	–	–	●	⊙	●	●
	JC	2090	82	5.1	6.6	5441	11,992	100%	–	–	–	–	–	⊗	⊗	●	●
	JC	2300	91	5.7	7.4	5892	12,986	100%	–	–	–	–	–	⊗	⊗	●	⊙
Severe Duty (SD)	HB2	1100	43	2.3	3.0	3282	7,234	90%	●	⊙	●	●	●	–	–	–	–
	HB2	1350	54	3.0	4.0	3736	8,234	90%	○	⊗	●	●	●	–	–	–	–
	HB2	1650	66	3.9	5.1	4163	9,175	90%	⊗	⊗	●	○	●	–	–	–	–
	HB2	1900	75	4.6	6.0	4553	10,035	90%	⊗	⊗	○	⊗	●	–	–	–	–
	JC	1960	77	4.6	6.0	6229	13,729	90%	–	–	–	–	–	⊙	○	●	●
	JC	2240	88	5.4	7.1	6809	15,007	90%	–	–	–	–	–	⊗	⊗	●	⊙
	JC	2350	93	5.7	7.5	7015	15,462	90%	–	–	–	–	–	⊗	⊗	●	⊙
	JC	2440	96	6.0	7.9	7342	16,182	90%	–	–	–	–	–	⊗	⊗	⊙	○
Extreme Duty (XD)	JC	2090	82	5.0	6.5	6557	14,452	90%	–	–	–	–	–	○	⊗	●	●
	JC	2240	88	5.4	7.1	7733	17,044	90%	–	–	–	–	–	⊗	⊗	⊙	○
	JC	2350	93	5.7	7.5	7968	17,562	90%	–	–	–	–	–	⊗	⊗	⊙	○
Maximum dynamic load pin-on (payload + bucket)								kg	7535	6350	10 420	8850	12 530	12 420	11 430	15 850	14 600
								lb	16,607	13,995	22,966	19,505	27,616	27,374	25,192	34,933	32,178

With Quick Coupler (CW-70)

Severe Duty (SD)	JC	2240	88	5.4	7.1	6559	14,456	90%	–	–	–	–	–	⊗	⊗	⊙	○
	JC	2350	93	5.7	7.5	6765	14,911	90%	–	–	–	–	–	⊗	⊗	⊙	○
Maximum dynamic load with CW coupler (payload + bucket)								kg	6115	4930	9000	7430	11 110	11 000	10 010	14 430	13 180
								lb	13,477	10,866	19,836	16,376	24,486	24,244	22,062	31,804	29,049

Maximum Material Density:

- 1800 kg/m³ (3,000 lb/yd³) or greater
- ⊙ 1500 kg/m³ (2,500 lb/yd³) or less
- 1200 kg/m³ (2,000 lb/yd³) or less
- ◇ 1200 kg/m³ (2,000 lb/yd³) or less, recommended for GD application only
- ⊗ Not Recommended

The above figures are based on maximum recommended dynamic working weights with front linkage fully extended at ground line with bucket curled. They do not exceed a stability ratio of 1.25.

Capacity based on ISO 7451.

Bucket weights include HD Long tips.

Caterpillar recommends using appropriate work tools to maximize the value customers receive from our products. Use of work tools, including buckets, which are outside of Caterpillar's recommendations or specifications for weight, dimensions, flows, pressures, etc. may result in less-than-optimal performance, including but not limited to reductions in production, stability, reliability, and component durability. Improper use of a work tool resulting in sweeping, prying, twisting and/or catching of heavy loads will reduce the life of the boom and stick.

Work Tool Offering Guide*

Boom Type	Reach Boom			General Purpose Boom			Mass Boom			
	Stick Size	R5.5 m (18'1")	R4.4 m (14'5")	R5.5 m (18'1")	R4.4 m (14'5")	GP3.7 m (12'2")	GP3.4 m (11'2")	GP2.92 m (9'7")	M3.4 m (11'2")	M2.92 m (9'7")
Multi-Processor		MP40**	MP40**	MP40						
Mobile Scrap and Demolition Shear				S365C**		S385C**	S385C	S385C	S385C	S385C
Rippers										
Contractor's Grapple										
Center-Lock Pin Grabber Coupler										
Dedicated Quick Coupler										

These work tools are available for the 390D L.
Consult your Cat dealer for proper match.

*Matches are dependent on excavator configurations. Consult your Cat dealer for proper work tool match.

**Pin-on only.

390D L Standard Equipment

Standard equipment may vary. Consult your Cat dealer for details.

ELECTRICAL

Alternator – 75 amp
Lights: Cab interior
Signal/warning horn
Power supply at battery compartment – 24V

ENGINE/POWER TRAIN

Automatic engine speed control
Automatic swing parking brake
Automatic travel parking brakes
Cat® C18 engine with ACERT™ Technology
Altitude capability to 2300 m (7,500 ft)
without derating
High ambient cooling, 52° C (125° F)
capability
Side-by-side cooling system
with separately mounted AC condenser
and variable speed fan
Two speed travel
Water separator
with level indicator for fuel line
Electric fuel priming pump

GUARDS

Heavy-duty travel motor guards
on upper frame
Heavy-duty swivel guard on undercarriage
Heavy-duty travel motor guards
on undercarriage

OPERATOR STATION

Air conditioner, heater and defroster
with automatic climate control
Ashtray and 24V lighter
Beverage/cup holder
Coat hook
Console-mounted, electronic-type joysticks
with adjustable gain and response
Floor mat
Instrument panel and gauges
with full color graphical display
Literature compartment
Neutral lever (lock-out) for all controls
Positive filtered ventilation
Pressurized cab
Retractable seat belt, 75 mm (3 in) wide
Stationary skylight (polycarbonate)
Sunshade for windshield and skylight
Travel control pedals
with removable hand levers
Windshield wipers and washers
(upper and lower)

UNDERCARRIAGE

Grease lubricated and positive pin
retention track
Hydraulic track adjusters
Long, variable gauge
Steps, four

OTHER STANDARD EQUIPMENT

Auxiliary hydraulic valve
for hydro-mechanical tools
Cat® one key security system
with locks for doors, cab and fuel cap
Catwalks, left and right sides
Crossroller-type swing bearing
Drive for auxiliary pump
Hand control pattern changer
Mirrors, left and right
S·O·SSM quick sampling valves
for engine oil and hydraulic oil
Steel firewall between engine
and hydraulic pumps
Wiring provisions for Cat® Product Link,
AutoLube System and lighted beacon

Optional equipment may vary. Consult your Cat dealer for details.

FRONT LINKAGE

- Bucket linkages
- VB family for VB sticks
(available with or without lifting eye)
- WB family for WB sticks
(available with or without lifting eye)
- Buckets – see charts
- Booms (with two working lights)
 - Mass Excavation – 7250 mm (285 in)
 - Reach – 10 000 mm (394 in)
 - GP – 8400 mm (330 in)
- Sticks
 - For Mass Boom
 - M2.92JC
 - M3.4JC
 - For Reach Boom
 - R5.5HB2
 - R4.4HB2
 - For GP Boom
 - R5.5HB2
 - R4.4HB2
 - GP3.4JC
 - GP2.92JC
- Tips, sidecutters and edge protectors

TRACK

- Double grouser, heavy duty
 - 650 mm (26 in)
 - 750 mm (30 in)
 - 900 mm (35 in)

GUARDS

- FOGS (Falling Object Guard System)
including overhead and windshield guards
- Track guiding guards
 - Full length
 - Center section
- Wire mesh screen for windshield
- Auxiliary controls and lines
 - Auxiliary boom lines
(high pressure or reach and mass booms)
 - Auxiliary stick lines
(high pressure for reach and mass booms)
- Basic control arrangements:
 - Single action – one way, high-pressure circuit for hammer application
 - Combined function – one way, high-pressure circuit for hammer application function for one-way or two-way high pressure

MISCELLANEOUS OPTIONS

- Boom lowering control device with SmartBoom™
- Cab front rain protector
- Converters, 7 amp-12V (two)
- Electric refueling pump
- Fine filtration filter
- Jump start terminals
- Reversible cooling fan
including protective screen
- Starting aid with ether for cold weather
- Stick lowering control device
- Travel alarm with cut-off switch

OPERATOR COMPARTMENT

- Joysticks
 - Four button joystick
for standard machine or single action auxiliary control
 - Thumb wheel modulation joystick
for use with combined auxiliary control
- Lunch box storage with lid
- Machine Security System
with programmable keys
- Radio
 - AM/FM radio-mounted in right console with antenna and two speakers
 - Radio-ready mounting at rear location including 24V to 12V converter, speakers, antenna
- Seat
 - Adjustable, high back
with mechanical suspension
 - Adjustable, high back
with air suspension
 - Adjustable, high back heated
with air suspension
- Straight travel pedal
- Windshield
 - One-piece, standard duty
 - One-piece, high impact resistant
70-30 split, sliding

390D L Hydraulic Excavator

For more complete information on Cat products, dealer services, and industry solutions, visit us on the web at www.cat.com

© 2013 Caterpillar Inc.
All rights reserved

Materials and specifications are subject to change without notice. Featured machines in photos may include additional equipment. See your Cat dealer for available options.

CAT, CATERPILLAR, SAFETY.CAT.COM, their respective logos, "Caterpillar Yellow" and the "Power Edge" trade dress, as well as corporate and product identity used herein, are trademarks of Caterpillar and may not be used without permission.

AEHQ6127-02 (01-2013)
Replaces AEHQ6127-01
(NACD, LACD)

