

374D L

Hydraulic Excavator



Engine

Engine Model	Cat® C15 ACERT® (ATAAC)	
Net Power – ISO 9249	355 kW	476 hp
Net Power – SAE J1349	355 kW	476 hp

Drive

Maximum Travel Speed	4.1 km/h	2.6 mph
Maximum Drawbar Pull – Long Undercarriage	492.5 kN	110,718 lb

Weights

Operating Weight – Long Undercarriage	71 132 kg	156,819 lb
• Reach boom, R3.6 (11'10") stick, 3.8 m ³ (5.0 yd ³) bucket, and 650 mm (26") shoes.		

374D L Features

Performance

High level of sustained production, improved trenching and pipe-laying performance, improved reliability and durability increase your productivity and lower your operating costs.

Engine

The Cat® C15 engine uses ACERT® Technology to meet U.S. EPA Tier 3 emission regulations, with exceptional performance capabilities and proven reliability.

Operator Station

Superior cab comfort and visibility provides an excellent working environment. The monitor is a full-color, graphical display with enhanced functionality to provide a simple, comprehensive machine interface.

Maximum Versatility

A variety of work tools, including buckets, are available for applications such as demolition, site clean-up, scrap processing, breaking up road surfaces and bedrock through Cat® Work Tools.

Service and Maintenance

Fast, easy service has been designed in with long service intervals, advanced filtration, convenient filter access and user-friendly electronic diagnostics for increased productivity and reduced maintenance costs.

Contents

Hydraulics	3
Operator Station.....	4
Engine	5
Control System	6
Structures.....	7
Undercarriage	8
Front Linkage	9
Buckets and Teeth	10
Work Tools.....	11
Environment	12
Service and Maintenance	13
Complete Customer Support.....	14
Hydraulic Excavator Specifications	15
Standard Equipment.....	24
Optional Equipment.....	25
Notes.....	26



The 374D L Series Excavator has excellent control, high stick and bucket forces, impressive lift capacity, simplified service and a comfortable operator station to increase your productivity and lower operating costs.

Hydraulics

Cat hydraulics deliver power and precise control to keep material moving

Main Pumps

The hydraulic system includes three pumps with an independent swing circuit. The hydraulic circuit utilizes a load-sensing system to ensure high hydraulic system efficiency and excellent productivity with little hydraulic loss.

- Large, heavy-duty main pumps and a separate swing pump provide quick cycle times during multi-function operation.

Reverse Swing Dampening Valve

Swing dampening valves reduce swing wag and produce smooth swing stops.

Advanced Features

The following are hydraulic system features of the 374D L.

- The electric re-generation system is incorporated into the hydraulic system to improve productivity and lower fuel consumption.
- The main pump flow has increased 10 percent to provide shorter cycle times.
- The main implement pressure has been increased 9 percent. This also provides shorter cycle times with higher digging forces, increased bucket fill factors.
- Stick cylinder diameter for mass and reach configurations has been increased along with the bucket cylinder diameter on the reach stick. These increases produce 17 percent higher digging forces.

Proportional Priority Pressure Compensation (PPPC) Hydraulics

Load-sensing, PPPC system, with Caterpillar-developed electronic actuation, provides high efficiency and excellent controllability.

- Cylinder speed is directly related to operator's movement of joystick from feathering to full speed.
- Flow to cylinders during multifunctional operation is directly controlled by the operator and is not dependent on loads.
- Controller reduces pump output to minimum to save power when joysticks are in neutral position.

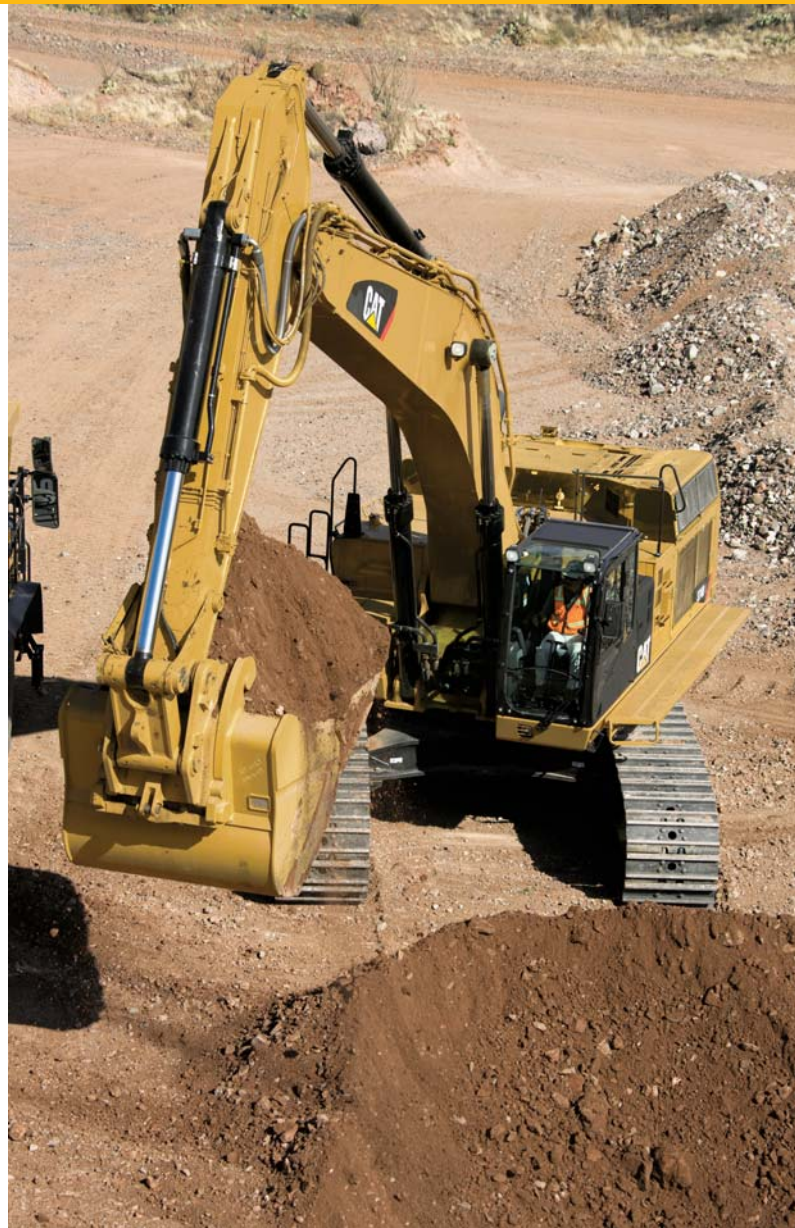

Operator Station

374D L is designed for simple, easy operation and comfort



Cab Design

The spacious cab provides visibility and ergonomics. The monitor is a full-color graphical display to provide the operator with easy-to-read, comprehensive machine information. The cab provides a comfortable environment for the operator.

Hydraulic Activation Control Lever

The hydraulic activation control lever deactivates hydraulic functions during engine start-up and prevents unintentional machine operation.

Cab Exterior

Utilizes thick steel tubing along the bottom perimeter of the cab, improving the resistance of fatigue and vibration. The cab structure allows the FOGS to be bolted directly to the cab, at the factory or as an attachment.

Cab Mounts

The cab shell is attached to the frame with viscous rubber cab mounts, which dampen vibrations and sound levels while enhancing operator comfort.

Additional Features

The 374D L operator station has many features for operator comfort.

- Premium KAB seats with adjustable height consoles.
- A rear view camera is offered as an attachment. The monitor functions as the display screen for the camera, providing added safety for the operator and surrounding work area.
- HID (High Intensity Discharge) lights are available as an attachment with time delay for the boom and cab lights.
- A two-way radio ready option is available.
- Automatic climate control for the air conditioner, heater and defroster.
- Fuel consumption can be displayed numerically on the monitor.



Engine

ACERT[®] Technology optimizes engine performance

Cat[®] C15 Engine

The Cat C15 engine with mechanically actuated electronic fuel injection (MEUI) powers the 374D L. The C15 has ACERT[®] Technology, a series of Caterpillar engineered innovations which provide advanced electronic control, precision fuel delivery and refined air management compliance.

Increased Power

The maximum power is 355 kW (476 hp), 18 percent more power than the 365C. The Power Management System (PMS) is also available to manage productivity and fuel economy.

Improved Fuel Efficiency

The 374D L fuel maps provide additional power and performance with optimized fuel consumption through flexible power settings incorporated into ADEM[™] controller.

Improved Reliability

The titanium-aluminum alloy rotor in the turbocharger improves reliability/durability and contributes to faster response of the turbocharger.

Hydraulic Cooling Fan

The 374D L uses a variable speed, hydraulically-driven fan for quieter operation and reduced fuel consumption during cooler ambient conditions.

Reversible Fan

A reversible fan option is offered as an attachment. The reverse function is operated through the monitor. By selecting this function, the fan rotates in the opposite direction for a preset time to help clean the cooling package for increased uptime and reduced service cost.

Control System

Electronic management



Monitor Display Screen

The monitor is a full color, 400 × 234 pixels Liquid Crystal Display (LCD). A master caution lamp blinks ON and OFF when one of the critical conditions below occurs:

- Engine oil pressure low
- Coolant temperature high
- Hydraulic oil temperature high

Under normal conditions or the default condition, the monitor display screen is divided into four areas: clock and throttle dial, gauge, event display and multi-information display.

Gauge Display

Three analog gauges, fuel level, hydraulic oil temperature and coolant temperature are displayed in this area.

Electronic Joysticks

Electronic joysticks provide features not possible with hydraulic pilot valves:

- Eliminate pilot lines in cab for quieter operation
- Simple pattern change through the monitor

Operator Gain/Response

This is used to suit the operator preference or application.

- Quicker for fast response
- Slower, for more precision
- Contains three preset settings with 21 available

Pattern Control Changer

The standard hand control pattern changer can be accessed through the monitor, to utilize either the standard excavator control pattern (SAE) or Backhoe Loader pattern (BHL).

Alternator

The alternator is 24 volt with 75 amp capacity and is driven by a serpentine belt off the front pulley. A snorkel pulls cool, clean air from the outside for increased service life.

Product Link

Product Link is standard on the 374D L. Product Link transmits diagnostic information from the machine back to Caterpillar, Cat dealers and customers.

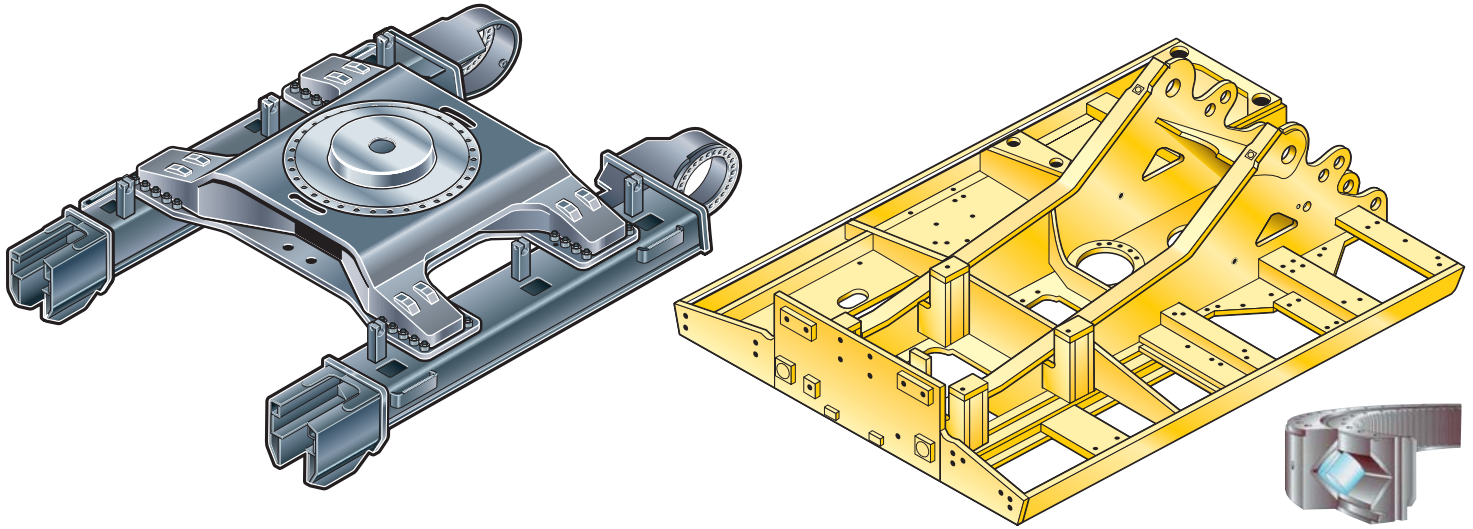

Structures

Rugged structures designed for maximum durability

Variable Gauge Undercarriage

The long variable gauge undercarriage is standard, providing a wide, stable base for operating, or a narrow gauge for reduced shipping width. The undercarriage gauge in working position has been increased by 160 mm (6.3 in) for improved stability.

Upper Frame

The upper frame is designed for maximum durability and efficient use of materials. The boomfoot, skirt and counterweight mounting area have been strengthened for longer service life and increased durability.

- Outer frame utilizes curved side rails, which are die-formed, for excellent uniformity and strength through the length
- Box section channels improve upper frame rigidity under the cab
- Boom tower and one piece main rails are constructed of solid, high-tensile strength steel plates

Catwalk

The catwalk width has been increased by 110 mm (4.3 in) from the 365C L. Catwalks are provided on both sides of the skirt for easy access of the maintenance points. Slip resistant plates are used on the full length of the catwalks.

Cross Roller Bearing

The 374D L swing bearing is a cross roller type, with 54 mm (2.13 in) diameter rollers. The cross rollers have a much greater contact area than ball bearing, providing increased stability and longer life.

Track Roller Frames

The track roller frame is made of thick, steel plate that is bent into a U-shape and welded to the bottom plate to create a box structure. The box structure design provides increased rigidity and impact resistance.

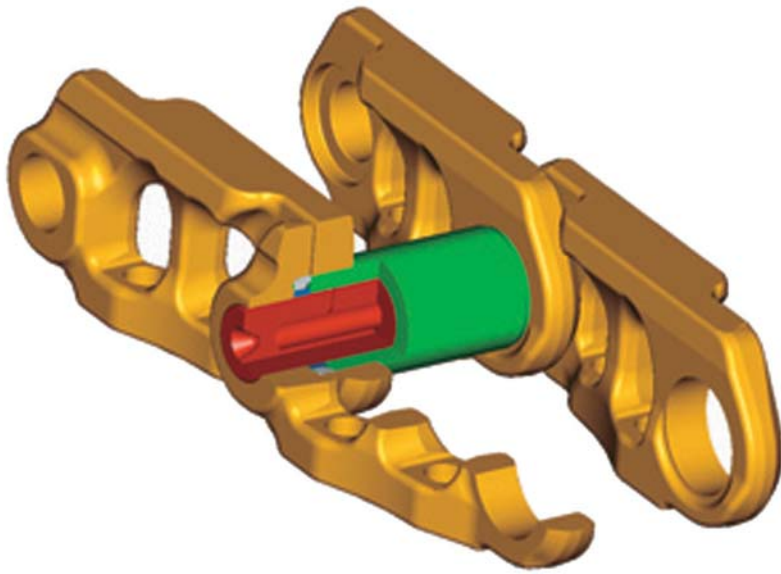

Undercarriage

The link that transmits the reaction forces from digging to the ground

Undercarriage

The undercarriage supports the swing bearing and upper structure and is the link that transmits the reaction forces from digging to the ground. The strength of the undercarriage plays a major factor in machine stability and durability.

Track Roller Frame

The track roller frame has been improved by installing a longer stroke recoil spring and lowering the front idler. The longer recoil spring improves durability and service life of the undercarriage while the offset idler increases the stability of the machine while working over the front.

Positive Pin Retention 2 (PPR2)

Track links with the PPR2 are provided as standard on the 374D L. The PPR2 track link is designed to prevent looseness of the track pin in the track link and to reduce stress concentrations. The PPR2 system eliminates pin walking for increased service life.

Carrier Rollers

The carrier rollers use a floating “Duo-Cone” seal. The Duo-Cone seal protects the moving parts in the carrier roller from water and dirt, and makes lubrication maintenance-free.

Front Linkage

Designed for flexibility and high productivity

Front Linkage

Cat excavator booms and sticks are built for performance and long service life.

- Castings and forgings are used at high stress areas such as boom nose, boom foot, boom cylinder and stick foot.
- All booms and sticks are stress-relieved for optimal life and durability, while minimizing weight for improved performance.
- All booms and sticks are ultrasonic inspected.

Bucket Linkage

Two bucket linkages are available for the 374D L. Both linkages are available with or without a lifting eye on the power link.

- The VB2 bucket linkage is for use with the reach sticks and VB2-family buckets
- The WB2 bucket linkage is for use with the mass sticks and WB2-family buckets

Boom Construction

374D L booms feature a large cross-section to improve strength and reduce weight. Baffle plates reinforce the boom interior for higher rigidity. Booms are designed for strength and maximum payload.

Stick Construction

Sticks are made of high-tensile strength steel in a box-section design, making them strong and light. All sticks are reinforced with a thick baffle plate for added rigidity. The connection between stick and boom is made of forged steel, and a thick steel plate is used at the bucket connecting location for increased strength and rigidity at load-bearing points. An additional wear plate is added to the working side of the stick for protection. All mass sticks include additional wear bars on the working side to protect the structure during operation. There are four reach sticks and two mass sticks available to meet your application needs.

Linkage Pins

Bucket cylinder pin and idler to stick pin diameter for the reach boom have been increased. The pins have thick chrome plating for high wear resistance and long life.

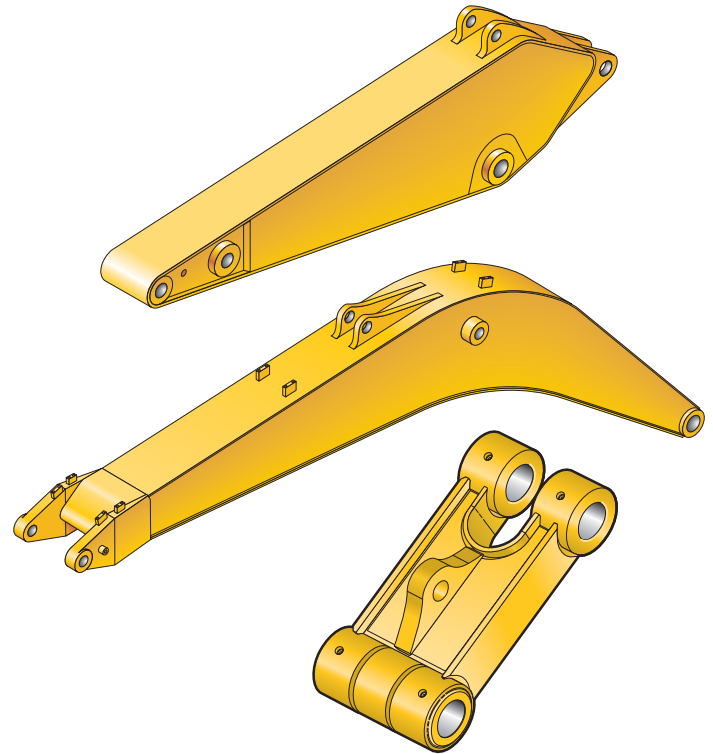

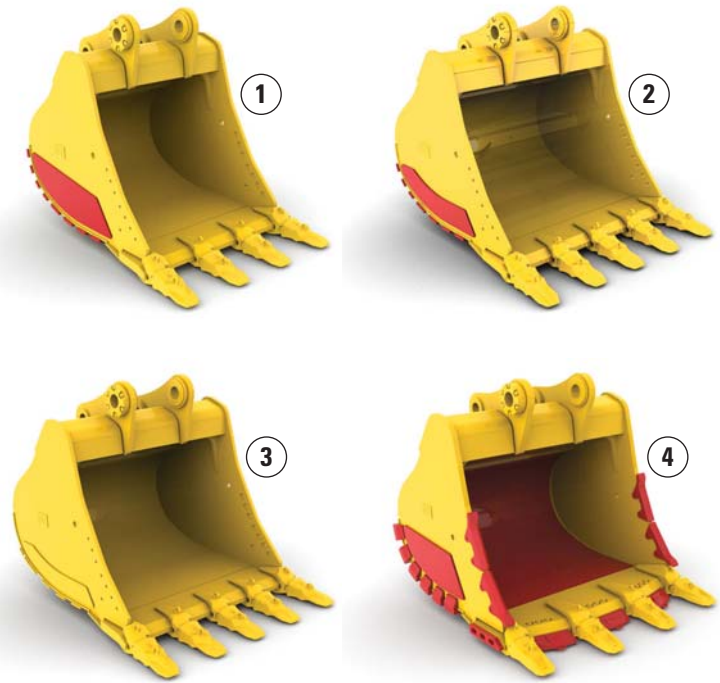

Buckets and Teeth

Designed and built for total system performance

Optimized Package

Caterpillar offers a wide range of buckets, each designed and field tested to function as an integral part of your excavator. All Cat Buckets feature K Series™ GET (Ground Engaging Tools). Buckets are available in four levels of durability and are built to take full advantage of the machine's power.

General Duty (GD)

General Duty buckets are designed for use in low impact, lower abrasion materials such as dirt, loam and mixed compositions of dirt and fine gravel.

Heavy Duty (HD)

Heavy Duty buckets are the most popular and a good “centerline” choice. This bucket style is a good starting point when application conditions are not known. Heavy Duty buckets are designed for a wide range of impact and abrasion conditions including mixed dirt, clay and rock.

Severe Duty (SD)

Severe Duty buckets are designed for higher abrasion conditions such as shot granite. When compared to the Heavy Duty bucket, wear bars and wear plates are substantially thicker and larger for added protection.

Extreme Duty (XD)

Extreme Duty buckets are designed for very high abrasion conditions such as granite quarries. Corner shrouds have been added and side wear plates are larger for added protection.

1) Severe Duty 2) Heavy Duty 3) General Duty 4) Extreme Duty

Work Tools

Solutions for your business

Increase Machine Versatility

The Cat combination of machine and tool provides a total solution for just about any application. Work tools can be mounted directly to the machine or a quick coupler can be added, making it quick and easy to release one work tool and pick up another.

Couplers

Caterpillar offers two quick coupler styles: dedicated and pin grabber. Each allows quick tool changes.

Center-Lock™ Pin Grabber Coupler

Center-Lock is the Caterpillar pin grabber style coupler and features a patent pending locking system. A highly visible secondary lock clearly shows the operator when the coupler is engaged or disengaged from the bucket or work tool.

Work Tools

An extensive range of Cat Work Tools for the 374D L includes buckets, hammers, grapples, shears, multi-processors and rippers. Each are designed to optimize the versatility and performance of your machine. Cat Work Tools and couplers are ready to work in a variety of applications, such as site and structure demolition, debris clean-up, truck loading, scrap processing, breaking road surfaces and bed rock.

Hydraulic Kits

Caterpillar offers field-installed hydraulic kits designed to simplify the process of ordering and installing the right kit. Modular kit designs integrate Cat Work Tools with Cat Hydraulic Excavators. Every kit is easy to install. Hoses are pre-made, tubes are pre-bent and pre-painted and there are comprehensive instructions.





Environment

374D L meets a wide range of environmental requirements

Emissions

ACERT® Technology is a differentiated technology that reduces emissions at the point of combustion. The technology capitalizes on proven Caterpillar leadership in three core engine systems: fuel, air and electronics.

Electro Magnetic Compliance

The 374D L meets the following EMC (Electro Magnetic Compliance) requirements:

- ISO 13766 Earth Moving Machinery – Electromagnetic compliance
- EU Directive 89/336/EEC
- Aus EMC Framework

Fluid Management

Several serviceability elements are designed into the 374D L to limit fluid spillage while performing routine maintenance.

Ecology Drains

Ecology drains are provided for the fuel and hydraulic tanks, allowing fluids to be captured in a container when draining the tanks.

Service and Maintenance

Fast, easy service has been designed into the 374D L

Service Intervals

Long service intervals reduce maintenance costs. Engine oil, oil filter and fuel filters are at 500 hours.

Oil Sample and Pressure Ports

Oil sample and pressure ports provide easy checking of machine condition and are standard on every machine.

Hydraulic Capsule Filters

The return filters or capsule filters for the hydraulic system are located beside the hydraulic tank. The filter elements are removable without spilling hydraulic oil.

Service Points

Service points are centrally located with easy access to facilitate routine maintenance.

Pilot Hydraulic System Filter

Pilot hydraulic system filter keeps contaminants from the pilot system and is located in the pump compartment.

Remote Greasing Block

A concentrated remote greasing block on the boom delivers grease to hard-to-reach locations.

Radial Seal Cleaner

Radial seal main air cleaner with precleaner has a double-layered filter element for more efficient filtration. No tools are required to change the element.

Fuel-Water Separator

The water separator removes water from fuel, even when under pressure, and the water level can be monitored in the cab.

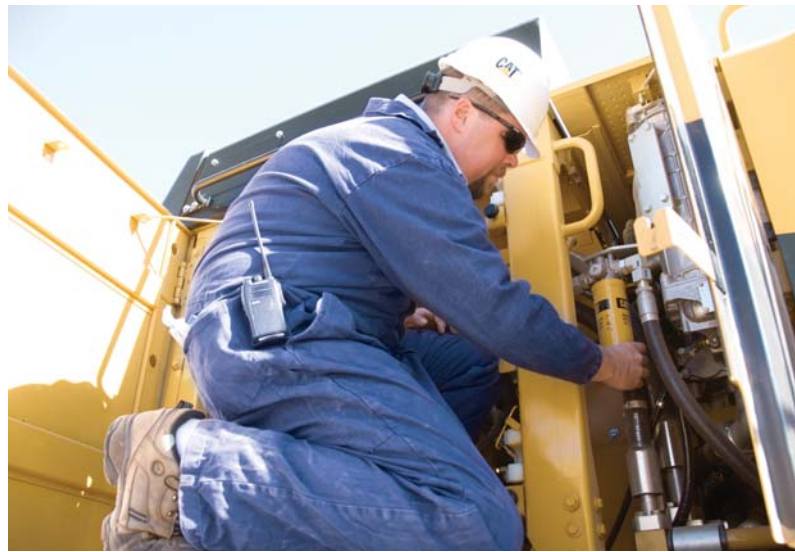

Complete Customer Support

Cat dealer services help you operate longer with lower costs



Product Support

Cat dealers utilize a worldwide computer parts network to minimize machine downtime. Save money with Cat remanufactured components.

Machine Selection

Make detailed comparisons of machines you are considering. What are job requirements and machine attachments? What production is needed? Your Cat dealer can provide recommendations.

Purchase

Consider financing options and day-to-day operating costs. Look at dealer services that can be included in the machine's cost to yield lower owning and operating costs over time.

Customer Support Agreements

Cat dealers offer a variety of product support agreements and work with you to develop a plan to meet specific needs. These plans can cover the entire machine, including attachments, to help protect your investment.

Operation

Improving operating techniques can boost your profits. Your Cat dealer has videos, literature and other ideas to help you increase productivity, and Caterpillar offers certified operator training to help maximize the return on your investment.

Maintenance Services

Repair option programs guarantee repair costs up front. Diagnostic programs such as Scheduled Oil Sampling, Coolant Sampling and Technical Analysis help you avoid unscheduled repairs.

Replacement

Repair, rebuild or replace? Your Cat dealer can help you evaluate the cost involved so you can make the right choice.

374D L Hydraulic Excavator Specifications

Engine

Engine Model	Cat® C15 ACERT® (ATAAC)	
Net Flywheel Power	355 kW	476 hp
Net Power – ISO 9249	355 kW	476 hp
Net Power – SAE J1349	355 kW	476 hp
Net Power – EEC 80/1269	355 kW	476 hp
Bore	137 mm	5.4 in
Stroke	171 mm	6.75 in
Displacement	15.2 L	928 in ³

- The 374D L meets worldwide Tier 3 emission requirements.
- No engine power derating required below 2300 m (7,500 ft) altitude.
- Net power advertised is the power available at the flywheel when the engine is equipped with fan, air cleaner, muffler and alternator.

Weights

Operating Weight – 71 132 kg 156,819 lb
Long Undercarriage

- Reach boom, R3.6 (11'10") stick, 3.8 m³ (5.0 yd³) bucket, and 650 mm (26") shoes.

Track

Standard with Long Undercarriage	900 mm	36 in
Optional for Long Undercarriage	750 mm	30 in
Optional for Long Undercarriage	650 mm	26 in
Number of Shoes Each Side – Long Undercarriage	47	
Number of Track Rollers Each Side – Long Undercarriage	8	
Number of Carrier Rollers Each Side	3	

Swing Mechanism

Swing Speed	6.4 rpm	
Swing Torque	214.8 kN·m	158,428 lb ft

Drive

Maximum Travel Speed	4.1 km/h	2.6 mph
Maximum Drawbar Pull – Long Undercarriage	492.5 kN	110,718 lb

Hydraulic System

Main System – Maximum Flow (Total)	880 L/min	232 gal/min
Swing System – Maximum Flow	360 L/min	95 gal/min
Maximum Pressure – Equipment – Normal	35 000 kPa	5,076 psi
Maximum Pressure – Travel	35 000 kPa	5,076 psi
Maximum Pressure – Swing	29 400 kPa	4,264 psi
Pilot System – Maximum Flow	87 L/min	23 gal/min
Pilot System – Maximum Pressure	4120 kPa	600 psi
Boom Cylinder – Bore	190 mm	7.5 in
Boom Cylinder – Stroke	1792 mm	70.6 in
Stick Cylinder – Bore	210 mm	8.3 in
Stick Cylinder – Stroke	2118 mm	83.4 in
VB2-Family Bucket Cylinder – Bore	190 mm	7.5 in
VB2-Family Bucket Cylinder – Stroke	1443 mm	56.8 in.
WB2-Family Bucket Cylinder – Bore	200 mm	7.9 in.
WB2-Family Bucket Cylinder – Stroke	1457 mm	57.4 in.

Service Refill Capacities

Fuel Tank Capacity	935 L	247 gal
Cooling System	95 L	25 gal
Engine Oil	65 L	17 gal
Swing Drive (each)	12 L	3.2 gal
Final Drive (each)	15 L	4 gal
Hydraulic System (including tank)	705 L	186 gal
Hydraulic Tank	360 L	95 gal

Sound Performance

Performance ANSI/SAE J1166 OCT98

- When properly installed and maintained, the cab offered by Caterpillar, when tested with doors and windows closed according to ANSI/SAE J1166 OCT98, meets OSHA and MSHA requirements for operator sound exposure limits in effect at time of manufacture.
- Hearing protection may be needed when operating with an open operator station and cab (when not properly maintained or doors/windows open) for extended periods or in a noisy environment.

Standards

Brakes	SAE J1026 APR90
Cab/FOGS	SAE J1356 FEB88 ISO 10262

374D L Hydraulic Excavator Specifications

Dimensions

All dimensions are approximate

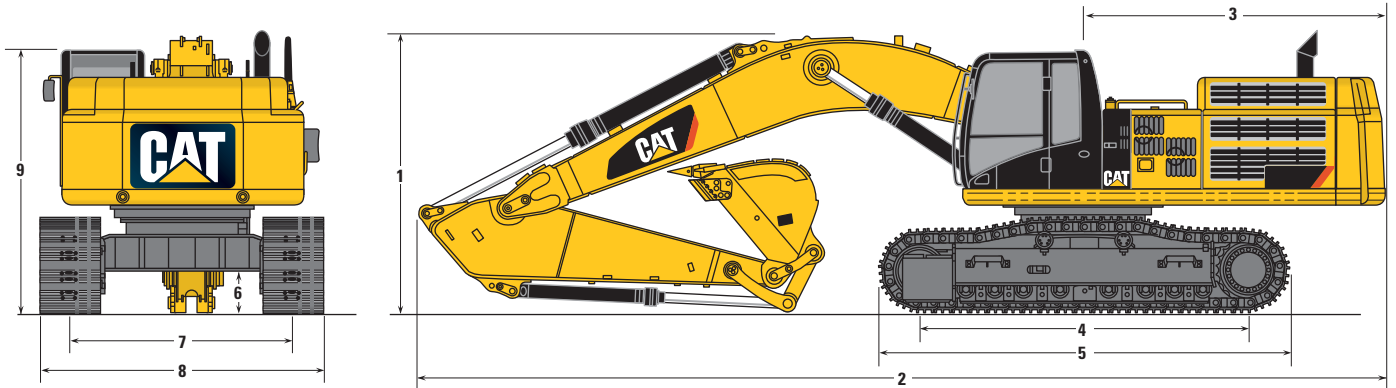

Stick	Reach Boom 7.8 m (25'7")				Mass Boom 7.0 m (23'0")	
	R4.67 m (15'4")	R4.15 m (13'7")	R3.6 m (11'10")	R2.84 m (9'4")	M3.0 m (9'10")	M2.57 m (8'5")
1 Shipping Height	4950 mm (16'3")	4620 mm (15'2")	4480 mm (14'8")	4250 mm (13'11")	4700 mm (15'5")	4610 mm (15'1")
2 Shipping Length	13 230 mm (43'5")	13 310 mm (43'8")	13 320 mm (43'8")	13 430 mm (44'1")	12 630 mm (41'5")	12 670 mm (41'7")
3 Tail Swing Radius	4015 mm (13'2")	4015 mm (13'2")	4015 mm (13'2")	4015 mm (13'2")	4015 mm (13'2")	4015 mm (13'2")
4 Length to Center of Rollers	4705 mm (15'5")	4705 mm (15'5")	4705 mm (15'5")	4705 mm (15'5")	4705 mm (15'5")	4705 mm (15'5")
5 Track Length	5870 mm (19'3")	5870 mm (19'3")	5870 mm (19'3")	5870 mm (19'3")	5870 mm (19'3")	5870 mm (19'3")
6 Ground Clearance	840 mm (2'9")	840 mm (2'9")	840 mm (2'9")	840 mm (2'9")	840 mm (2'9")	840 mm (2'9")
7 Track Gauge (Shipping)*	2750 mm (9'0")	2750 mm (9'0")	2750 mm (9'0")	2750 mm (9'0")	2750 mm (9'0")	2750 mm (9'0")
8 Transport Width**	3500 mm (11'6")	3500 mm (11'6")	3500 mm (11'6")	3500 mm (11'6")	3500 mm (11'6")	3500 mm (11'6")
9 Cab Height	3540 mm (11'7")	3540 mm (11'7")	3540 mm (11'7")	3540 mm (11'7")	3540 mm (11'7")	3540 mm (11'7")

* Track gauge in extended (working) position: 3410 mm (11'2").

** Transport width shown for 750 mm (30 in).

Add 150 mm (6 in) for 900 mm (36 in) shoes.

Subtract 100 mm (4 in) for 650 mm (26 in) shoes.

Working Ranges

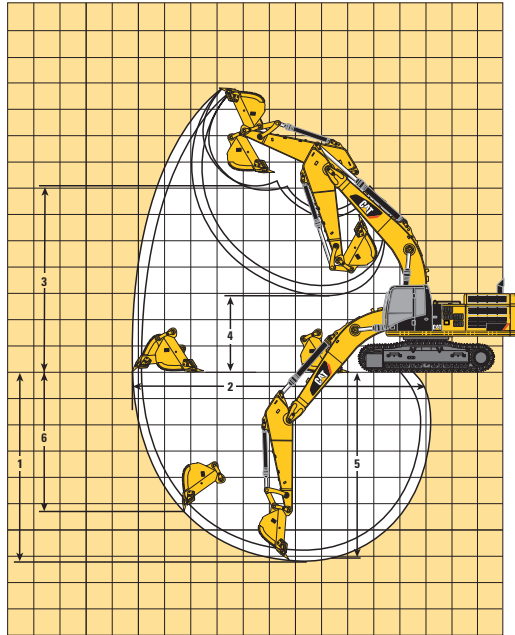

	Reach Boom 7.8 m (25'7")				Mass Boom 7.0 m (23'0")	
Stick	R4.67 m (15'4")	R4.15 m (13'7")	R3.6 m (11'10")	R2.84 m (9'4")	M3.0 m (9'10")	M2.57 m (8'5")
Bucket	GP (3.8 m³)	GP (3.8 m³)	GP (3.8 m³)	GP (3.8 m³)	HDR (4.6 m³)	HDR (4.6 m³)
1 Maximum Digging Depth	9660 mm (31'8")	9140 mm (30'0")	8590 mm (28'2")	7830 mm (25'8")	7650 mm (25'1")	7230 mm (23'9")
2 Maximum Reach at Ground Line	14 230 mm (46'8")	13 690 mm (44'11")	13 170 mm (43'3")	12 530 mm (41'1")	11 850 mm (38'11")	11 460 mm (37'7")
3 Maximum Loading Height	8990 mm (29'6")	8640 mm (28'4")	8410 mm (27'7")	8240 mm (27'0")	7240 mm (23'9")	7070 mm (23'2")
4 Minimum Loading Height	2230 mm (7'4")	2750 mm (9'0")	3300 mm (10'10")	4060 mm (13'4")	3060 mm (10'0")	3480 mm (11'5")
5 Maximum Depth Cut for 2240 mm (8') Level Bottom	9550 mm (31'4")	9020 mm (29'7")	8460 mm (27'9")	7680 mm (25'2")	7510 mm (24'8")	7070 mm (23'2")
6 Maximum Vertical Wall Digging Depth	8450 mm (27'9")	7750 mm (25'5")	7050 mm (23'2")	6580 mm (21'7")	4330 mm (14'2")	3960 mm (13'0")
Bucket Digging Force (SAE)	297.5 kN (66,881 lb-f)	297.5 kN (66,881 lb-f)	296.9 kN (66,746 lb-f)	295.3 kN (66,386 lb-f)	342.1 kN (76,907 lb-f)	347.0 kN (78,009 lb-f)
Bucket Digging Force (ISO)	339.4 kN (76,300 lb-f)	339.4 kN (76,300 lb-f)	338.6 kN (76,120 lb-f)	336.8 kN (75,716 lb-f)	384.0 kN (86,327 lb-f)	389.8 kN (87,631 lb-f)
Stick Digging Force (SAE)	227.1 kN (51,054 lb-f)	245.6 kN (55,213 lb-f)	269.4 kN (60,564 lb-f)	299.7 kN (67,375 lb-f)	296.5 kN (66,656 lb-f)	322.7 kN (72,546 lb-f)
Stick Digging Force (ISO)	234.0 kN (56,605 lb-f)	253.9 kN (57,079 lb-f)	279.3 kN (62,789 lb-f)	312.1 kN (70,163 lb-f)	305.0 kN (68,567 lb-f)	332.9 kN (74,839 lb-f)

374D L Hydraulic Excavator Specifications

Operating Weight and Ground Pressure

	Track					
	900 mm (36 in) Shoes		750 mm (30 in) Shoes		650 mm (26 in) Shoes	
	kg (lb)	kPa (psi)	kg (lb)	kPa (psi)	kg (lb)	kPa (psi)
Reach Boom 7.8 m (25'7")						
GP Bucket 3.8 m ³ (5.00 yd ³)						
R4.67 m (15'4")	73 221 (161,425)	78.0 (11.3)	72 172 (159,112)	92.3 (13.4)	71 494 (157,617)	105.5 (15.3)
R4.15 m (13'7")	73 010 (160,959)	77.8 (11.3)	71 961 (158,647)	92.0 (13.3)	71 283 (157,152)	105.2 (15.2)
R3.60 m (11'10")	72 859 (160,627)	77.6 (11.3)	71 810 (158,314)	91.8 (13.3)	71 132 (156,819)	104.9 (15.2)
R2.84 m (9'4")	72 686 (160,245)	77.4 (11.2)	71 637 (157,933)	91.6 (13.3)	70 959 (156,438)	104.7 (15.2)
Mass Boom 7.0 m (23'0")						
HDR Bucket 4.6 m ³ (6.00 yd ³)						
M3.00 m (9'10")	75 596 (166,661)	80.5 (11.7)	74 547 (164,348)	95.3 (13.8)	73 869 (162,853)	109.0 (15.8)
M2.57 m (8'5")	75 422 (166,277)	80.4 (11.7)	74 373 (163,964)	95.1 (13.8)	73 695 (162,470)	108.7 (15.8)

Major Component Weights

	kg	lb
Base machine with counterweight and 750 mm (30 in) shoes (without front linkage)	57 700	127,229
Two boom cylinders	1400	3,087
Counterweight		
Removal type	10 200	22,491
Non-removal type	10 960	24,167
Boom (includes lines, pins, stick cylinder)		
Reach Boom 7.8 m (25'7")	6730	14,840
Mass Boom 7.0 m (23'0")	6900	15,215
Stick (includes lines, pins, bucket cylinder and linkage)		
R4.67 m (15'4")	4000	8,820
R4.15 m (13'7")	3790	8,357
R3.60 m (11'10")	3670	8,092
R2.84 m (9'4")	3470	7,651
M3.00 m (9'10")	4070	8,974
M2.57 m (8'5")	4240	9,349

Reach Boom Lift Capacities



Load Point Height



Load at Maximum Reach



Load Radius Over Front



Load Radius Over Side

Boom – 7.8 m (25 ft 7 in)

Coupler – N/A

Bucket – None

Stick – R4.67 m (15 ft 4 in)

Shoes – 900 mm (36 in) double grouser (HD)

Load Point Height	1.5 m/5.0 ft		3.0 m/10.0 ft		4.5 m/15.0 ft		6.0 m/20.0 ft		7.5 m/25.0 ft		9.0 m/30.0 ft		10.5 m/35.0 ft		12.0 m/40.0 ft		Load Radius Over Side		m ft	
	kg lb	kg lb	kg lb	kg lb	kg lb	kg lb	kg lb	kg lb	kg lb	kg lb	kg lb	kg lb	kg lb	kg lb	kg lb	kg lb	kg lb	kg lb		
10.5 m 35.0 ft												*11 750	*11 750					*10 800	*10 800	9.20
9.0 m 30.0 ft												*12 450	*12 450					*10 200	*10 200	10.33
7.5 m 25.0 ft												*27,800	*27,800	*12 250	11 900			*9900	*9900	11.14
6.0 m 20.0 ft												*13 450	*13 450	*26,550	25,450			*21,850	*21,850	36.36
4.5 m 15.0 ft					*26 500	*26 500	*20 000	*20 000	*16 550	*16 550	*14 450	*14 450	*13 050	11 700				*9850	9650	11.70
3.0 m 10.0 ft							*23 050	*23 050	*18 300	*18 300	*15 450	13 950	*13 600	11 050	*12 050	8900		*21,700	19,900	12.04
1.5 m 5.0 ft							*25 350	24 100	*19 750	17 450	*16 350	13 400	*14 100	10 700	12 100	8750		*10 850	8550	12.16
Ground Line					*17 300	*17 300	*26 500	23 200	*20 650	16 800	*16 950	13 000	*14 350	10 450				*11 700	8700	11.93
-1.5 m -5.0 ft			*12 500	*12 500	*22 700	*22 700	*26 400	22 750	*20 800	16 450	*17 000	12 750	*14 200	10 300				*27,400	20,050	37.71
-3.0 m -10.0 ft	*15 350	*15 350	*19 700	*19 700	*30 800	*30 800	*25 250	22 650	*20 100	16 300	*16 350	12 650	*13 250	10 300				*12 450	9900	10.85
-4.5 m -15.0 ft			*28 450	*28 450	*29 000	*29 000	*22 850	*22 850	*18 300	16 450	*14 600	12 750						*12 250	11 300	9.92
-6.0 m -20.0 ft			*29 550	*29 550	*23 450	*23 450	*18 800	*18 800	*14 800	*14 800	*31,150	27,550						*25,200	*25,200	28.01

Boom – 7.8 m (25 ft 7 in)

Coupler – N/A

Bucket – None

Stick – R4.15 m (13 ft 7 in)

Shoes – 900 mm (36 in) double grouser (HD)

Load Point Height	1.5 m/5.0 ft		3.0 m/10.0 ft		4.5 m/15.0 ft		6.0 m/20.0 ft		7.5 m/25.0 ft		9.0 m/30.0 ft		10.5 m/35.0 ft		Load Radius Over Side		m ft		
	kg lb	kg lb	kg lb	kg lb	kg lb	kg lb	kg lb	kg lb	kg lb	kg lb	kg lb	kg lb	kg lb	kg lb	kg lb	kg lb			
10.5 m 35.0 ft																	*12 450	*12 450	8.47
9.0 m 30.0 ft												*13 350	*13 350				*27,700	*27,700	27.25
7.5 m 25.0 ft												*29,400	*29,400				*11 750	*11 750	9.68
6.0 m 20.0 ft												*13 550	*13 550	*11 800	11 750		*25,950	*25,950	31.45
4.5 m 15.0 ft												*13 550	*13 550				*11 400	*11 400	10.55
3.0 m 10.0 ft												*29,600	*29,600				*25,200	*25,200	34.41
1.5 m 5.0 ft												*15 800	*15 800				*11 400	*11 400	10.55
Ground Line												*14 200	*14 200	*13 150	11 600		*30,900	*30,900	28.80
-1.5 m -5.0 ft			*13 350	*13 350	*24 050	*24 050	*26 350	22 900	*20 850	16 550	*17 050	12 850	*14 100	10 450			*28,800	24,900	36.44
-3.0 m -10.0 ft			*30,200	*30,200	*55,050	*55,050	*57,100	49,300	*45,200	35,700	*36,900	27,700	*30,350	22,500			*25,550	21,500	37.69
-4.5 m -15.0 ft			*22 100	*22 100	*31 450	*31 450	*24 750	22 950	*19 850	16 500	*16 100	12 850					*11 400	9750	11.50
-6.0 m -20.0 ft			*49,800	*49,800	*68,300	*68,300	*53,550	49,350	*42,850	35,600	*34,650	27,700					*25,550	21,500	37.69
-4.5 m -15.0 ft			*32 500	*32 500	*27 200	*27 200	*21 850	*21 850	*17 550	16 700	*13 650	13 050					*12 900	12 650	9.25
-6.0 m -20.0 ft			*73,600	*73,600	*58,750	*58,750	*47,050	*47,050	*37,650	36,050	*28,700	28,250					*28,350	28,100	30.16
-6.0 m -20.0 ft					*20 850	*20 850	*17 000	*17 000	*13 000	*13 000							*11 850	*11 850	7.85
-6.0 m -20.0 ft					*44,450	*44,450	*36,000	*36,000	*26,750	*26,750							*25,850	*25,850	25.40

*Indicates that the load is limited by hydraulic lifting capacity rather than tipping load. The above loads are in compliance with hydraulic excavator lift capacity standard ISO 10567:2007. They do not exceed 87% of hydraulic lifting capacity or 75% of tipping load. Lifting capacities are based on the machine standing on a firm, uniform supporting surface.

Weight of all lifting accessories must be deducted from the above lifting capacities.

Lifting point for all charts is stick nose.

Always refer to the appropriate Operation and Maintenance Manual for specific product information.

374D L Hydraulic Excavator Specifications

Reach Boom Lift Capacities



Load Point Height



Load at Maximum Reach



Load Radius Over Front



Load Radius Over Side



Boom – 7.8 m (25 ft 7 in)

Coupler – N/A

Bucket – None

Stick – R3.6 m (11 ft 10 in)

Shoes – 900 mm (36 in) double grouser (HD)

	1.5 m/5.0 ft		3.0 m/10.0 ft		4.5 m/15.0 ft		6.0 m/20.0 ft		7.5 m/25.0 ft		9.0 m/30.0 ft		10.5 m/35.0 ft				m ft	
	kg lb	kg lb	kg lb	kg lb	kg lb	kg lb	kg lb	kg lb	kg lb	kg lb	kg lb	kg lb	kg lb	kg lb	kg lb	kg lb		
10.5 m 35.0 ft																*14 850 *33,100	*14 850 *33,100	7.75 24.84
9.0 m 30.0 ft												*14 350	*14 350			*13 900 *30,700	*13 900 *30,700	9.06 29.39
7.5 m 25.0 ft										*15 450 *33,600	*15 450 *33,600	*14 300 *31,300	*14 300 *31,300			*13 500 *29,750	12 600 28,100	9.98 32.54
6.0 m 20.0 ft							*19 600 *42,300	*19 600 *42,300	*16 650 *36,100	*16 650 *36,100	*14 850 *32,350	14 750 31,750	*13 800	11 450	*13 450 *29,600	11 250 24,900	10.60 34.68	
4.5 m 15.0 ft							*22 500 *48,500	*22 500 *48,500	*18 200 *39,400	*18 200 *39,400	*15 650 *34,050	14 250 30,750	*14 050 *30,650	11 250 24,100	*13 700 *30,150	10 400 23,000	10.98 35.99	
3.0 m 10.0 ft							*25 150 *54,250	24 700 53,300	*19 700 *42,600	17 950 38,650	*16 500 *35,800	13 800 29,700	*14 450 *31,350	10 950 23,550	*13 750 *30,250	10 000 22,000	11.15 36.57	
1.5 m 5.0 ft							*26 650 *57,650	23 650 50,950	*20 750 *44,950	17 250 37,150	*17 150 *37,150	13 350 28,750	*14 650 *31,800	10 700 23,050	13 650 30,000	9900 21,750	11.11 36.45	
Ground Line					*34,650	*34,650	*26 850 *58,200	23 100 49,750	*21 150 *45,750	16 800 36,200	*17 350 *37,550	13 050 28,100	*14 550 *31,350	10 550 22,750	*13 900 *30,600	10 100 22,200	10.86 35.63	
-1.5 m -5.0 ft					*24 650 *56,500	*24 650 *56,500	*25 900 *56,150	23 000 49,450	*20 700 *44,800	16 600 35,750	*16 900 *36,500	12 900 27,850			*13 900 *30,650	10 700 23,550	10.39 34.04	
-3.0 m -10.0 ft				*24 250 *54,750	*24 250 *54,750	*29 550 *64,150	*23 850 *51,600	23 100 49,700	*19 250 *41,550	16 650 35,850	*15 500 *33,150	13 000 28,000			*13 750 *30,300	11 900 26,250	9.65 31.58	
-4.5 m -15.0 ft				*29 150 *63,150	*29 150 *63,150	*24 750 *53,500	*24 750 *53,500	*20 350 *43,850	*20 350 *43,850	*16 350 *34,900	*16 350 *34,900					*13 200 *28,950	*13 200 *28,950	8.60 28.01
-6.0 m -20.0 ft							*14 450 *30,200	*14 450 *30,200								*11 400 *24,700	*11 400 *24,700	7.07 22.79



Boom – 7.8 m (25 ft 7 in)

Coupler – N/A

Bucket – None

Stick – R2.84 m (9 ft 4 in)

Shoes – 900 mm (36 in) double grouser (HD)

	1.5 m/5.0 ft		3.0 m/10.0 ft		4.5 m/15.0 ft		6.0 m/20.0 ft		7.5 m/25.0 ft		9.0 m/30.0 ft		10.5 m/35.0 ft				m ft	
	kg lb	kg lb	kg lb	kg lb	kg lb	kg lb	kg lb	kg lb	kg lb	kg lb	kg lb	kg lb	kg lb	kg lb	kg lb	kg lb		
10.5 m																*17 550	*17 550	6.81
9.0 m 30.0 ft										*16 300 *35,850	*16 300 *35,850					*16 050 *35,600	*16 050 *35,600	8.28 26.78
7.5 m 25.0 ft										*16 700 *36,400	*16 700 *36,400	*15 500 *34,000	14 800 31,750			*15 400 *34,000	14 050 31,350	9.27 30.21
6.0 m 20.0 ft					*28 400 *60,550	*28 400 *60,550	*21 300 *45,900	*21 300 *45,900	*17 800 *38,600	*17 800 *38,600	*15 800 *34,400	14 550 31,300			*15 050 *33,200	12 350 27,400	9.94 32.51	
4.5 m 15.0 ft							*24 100 *51,900	*24 100 *51,900	*19 200 *41,550	18 450 39,800	*16 450 *35,700	14 100 30,400			*14 900 *32,850	11 400 25,150	10.35 33.91	
3.0 m 10.0 ft							*26 300 *56,750	24 150 52,100	*20 450 *44,250	17 650 38,150	*17 100 *37,050	13 650 29,450	*14 900	10 950	*14 850 *32,750	10 900 24,000	10.52 34.52	
1.5 m 5.0 ft							*27 050 *58,600	23 350 50,350	*21 200 *45,900	17 100 36,850	*17 500 *37,900	13 300 28,700			*14 850 *32,700	10 800 23,750	10.48 34.40	
Ground Line							*26 500 *57,500	23 100 49,700	*21 150 *45,850	16 800 36,150	*17 350 *37,600	13 100 28,250			*14 800 *32,600	11 100 24,400	10.22 33.52	
-1.5 m -5.0 ft					*23 400 *54,350	*23 400 *54,350	*24 900 *54,100	23 150 49,750	*20 250 *43,800	16 700 36,000	*16 450 *35,450	13 050 28,200			*14 650 *32,750	11 900 26,200	9.71 31.82	
-3.0 m -10.0 ft					*26 200 *57,100	*26 200 *57,100	*22 250 *48,150	*22 250 *48,150	*18 150 *39,150	16 900 36,400					*14 150 *31,150	13 450 29,800	8.92 29.17	
-4.5 m -15.0 ft					*20 850 *45,000	*20 850 *45,000	*17 900 *38,300	*17 900 *38,300	*13 900 *28,900	*13 900 *28,900					*12 900 *28,200	*12 900 *28,200	7.76 25.25	

*Indicates that the load is limited by hydraulic lifting capacity rather than tipping load. The above loads are in compliance with hydraulic excavator lift capacity standard ISO 10567:2007. They do not exceed 87% of hydraulic lifting capacity or 75% of tipping load. Lifting capacities are based on the machine standing on a firm, uniform supporting surface.

Weight of all lifting accessories must be deducted from the above lifting capacities.

Lifting point for all charts is stick nose.

Always refer to the appropriate Operation and Maintenance Manual for specific product information.

Mass Boom Lift Capacities



Load Point Height



Load at Maximum Reach



Load Radius Over Front



Load Radius Over Side

















Boom – 7.0 m (23 ft 0 in)

Coupler – N/A

Bucket – None

Stick – M3.0 m (9 ft 10 in)

Shoes – 900 mm (36 in) double grouser (HD)

	1.5 m/5.0 ft		3.0 m/10.0 ft		4.5 m/15.0 ft		6.0 m/20.0 ft		7.5 m/25.0 ft		9.0 m/30.0 ft				m ft	
																
9.0 m 30.0 ft	kg lb													*13 850 *30,750	*13 850 *30,750	7.35 23.67
7.5 m 25.0 ft	kg lb								*16 250 *35,600	*16 250 *35,600				*13 100 *28,950	*13 100 *28,950	8.45 27.50
6.0 m 20.0 ft	kg lb						*19 550 *42,300	*19 550 *42,300	*17 050 *37,050	*17 050 *37,050	*15 700 *28,500	14 300 *28,500	*12 900 *28,450	*12 900 *28,450	9.18 30.01	
4.5 m 15.0 ft	kg lb				*30 350 *65,000	*30 350 *65,000	*22 250 *48,000	*22 250 *48,000	*18 350 *39,750	*18 350 *39,750	*16 150 *35,150	14 000 30,050	*13 150 *28,900	12 500 27,650	9.62 31.52	
3.0 m 10.0 ft	kg lb						*24 850 *53,600	24 800 53,400	*19 700 *42,700	17 800 38,350	*16 750 *36,400	13 550 29,150	*13 750 *30,200	11 850 26,150	9.81 32.18	
1.5 m 5.0 ft	kg lb						*26 450 *57,200	23 700 51,050	*20 700 *44,850	17 150 36,950	*17 200 *37,250	13 200 28,400	*14 800 *32,500	11 700 25,800	9.76 32.04	
Ground Line	kg lb				*29 000 *67,300	*29 000 *67,300	*26 700 *57,800	23 150 49,800	*20 950 *45,400	16 750 36,050	*17 100 *36,900	12 950 27,950	*15 950 *35,150	12 100 26,600	9.48 31.10	
-1.5 m -5.0 ft	kg lb			*23 900 *53,950	*23 900 *53,950	*32 900 *71,500	*32 900 *71,500	*25 550 *55,400	23 000 49,500	*20 200 *43,700	16 600 35,750		*16 050 *35,300	13 100 28,950	8.93 29.26	
-3.0 m -10.0 ft	kg lb			*35 400 *77,150	*35 400 *77,150	*28 850 *62,600	*28 850 *62,600	*22 900 *49,400	*22 900 *49,400	*17 850 *38,100	16 800 36,250		*15 800 *34,750	15 300 33,900	8.06 26.35	
-4.5 m -15.0 ft	kg lb					*22 350 *47,800	*22 350 *47,800	*17 550 *37,050	*17 550 *37,050				*14 600 *31,950	*14 600 *31,950	6.76 21.91	

















Boom – 7.0 m (23 ft 0 in)

Coupler – N/A

Bucket – None

Stick – M2.57 m (8 ft 5 in)

Shoes – 900 mm (36 in) double grouser (HD)

	1.5 m/5.0 ft		3.0 m/10.0 ft		4.5 m/15.0 ft		6.0 m/20.0 ft		7.5 m/25.0 ft		9.0 m/30.0 ft				m ft	
																
9.0 m 30.0 ft	kg lb													*16 700 *37,100	*16 700 *37,100	6.82 21.91
7.5 m 25.0 ft	kg lb								*17 200 *37,750	*17 200 *37,750				*15 700 *34,650	*15 700 *34,650	8.00 26.00
6.0 m 20.0 ft	kg lb						*20 600 *44,550	*20 600 *44,550	*17 800 *38,750	*17 800 *38,750				*15 450 *34,050	14 850 32,950	8.77 28.65
4.5 m 15.0 ft	kg lb						*23 200 *50,050	*23 200 *50,050	*19 000 *41,200	18 500 39,850	*16 700 *36,450	13 950 29,900	*15 750 *34,650	13 350 29,550	9.23 30.23	
3.0 m 10.0 ft	kg lb						*25 550 *55,200	24 550 52,950	*20 250 *43,800	17 750 38,250	*17 150 *37,300	13 550 29,200	*16 500 *36,300	12 650 27,900	9.43 30.92	
1.5 m 5.0 ft	kg lb						*26 800 *58,000	23 600 50,850	*21 000 *45,550	17 150 36,950	*17 400 *37,750	13 250 28,550	*16 650 *36,700	12 500 27,550	9.38 30.78	
Ground Line	kg lb				*26 950 *63,150	*26 950 *63,150	*26 650 *57,750	23 200 49,900	*21 050 *45,550	16 800 36,200	*17 000 *37,000	13 100	*16 750 *36,950	12 950 28,550	9.08 29.79	
-1.5 m -5.0 ft	kg lb			*55,000	*55,000	*31 500 *68,600	*31 500 *68,600	*25 100 *54,400	23 200 49,850	*19 900 *43,000	16 750 36,150		*16 750 *36,900	14 200 31,300	8.50 27.86	
-3.0 m -10.0 ft	kg lb			*31 000 *67,800	*31 000 *67,800	*27 100 *58,750	*27 100 *58,750	*21 900 *47,150	*21 900 *47,150	*16 650 *36,150			*16 250 *35,750	*16 250 *35,750	7.59 24.78	
-4.5 m -15.0 ft	kg lb					*19 700 *42,000	*19 700 *42,000	*15 150 *33,000	*15 150 *33,000				*14 350 *31,200	*14 350 *31,200	6.18 20.00	

*Indicates that the load is limited by hydraulic lifting capacity rather than tipping load. The above loads are in compliance with hydraulic excavator lift capacity standard ISO 10567:2007. They do not exceed 87% of hydraulic lifting capacity or 75% of tipping load. Lifting capacities are based on the machine standing on a firm, uniform supporting surface.

Weight of all lifting accessories must be deducted from the above lifting capacities.

Lifting point for all charts is stick nose.

Always refer to the appropriate Operation and Maintenance Manual for specific product information.

374D L Hydraulic Excavator Specifications

Bucket Specifications and Compatibility

	Linkage	Width		Capacity		Weight		Fill	ME boom 7.0 m		GP boom 7.8 m				
		mm	in	m ³	yd ³	kg	lb		%	M2.57WB2	M3.0WB2	R2.84VB2	R3.6VB2	R4.15VB2	R4.67VB2
Without Quick Coupler															
General Duty (GD)	VB2	1525	60	2.9	3.9	3205	7,064	100%			●	●	●	⊙	
	VB2	1900	75	3.8	5.0	3622	7,982	100%			●	●	●	○	
	VB2	1900	75	3.8	5.0	3720	8,198	100%			●	●	●	○	
	WB2	2000	79	4.6	6.0	4016	8,851	100%	●	●					
	WB2	2100	83	5.0	6.5	4167	9,184	100%	●	⊙					
General Duty XL (GDXL)	VB2	2000	79	4.6	6.0	4077	8,986	100%			⊙	○	⊗	⊗	
Heavy Duty (HD)	VB2	1220	48	2.2	2.9	2892	6,373	100%			●	●	●	●	
	VB2	1700	66	3.3	4.3	3529	7,778	100%			●	●	⊙	○	
	VB2	1900	75	3.8	5.0	3881	8,553	100%			●	⊙	○	⊗	
	VB2	1900	75	3.8	5.0	3782	8,336	100%			●	⊙	○	⊗	
	WB2	2100	83	5.0	6.5	4345	9,576	100%	●	⊙					
	WB2	2250	89	5.3	7.0	4591	10,119	100%	⊙	⊙					
Severe Duty (SD)	VB2	1100	43	1.9	2.5	2840	6,259	90%			●	●	●	●	
	VB2	1525	60	2.9	3.9	3453	7,610	90%			●	●	●	●	
	VB2	1700	66	3.3	4.3	3653	8,051	90%			●	●	●	⊙	
	VB2	1900	75	3.8	5.0	4016	8,851	90%			●	⊙	○	○	
	WB2	1800	71	3.7	4.8	4667	10,286	90%	●	●					
	WB2	1900	75	4.0	5.25	4825	10,634	90%	●	●					
	WB2	2000	79	4.4	5.75	4982	10,980	90%	●	●					
	WB2	2100	83	4.6	6.0	5141	11,331	90%	●	●					
Extreme Duty (XD)	WB2	2200	87	5.0	6.5	5341	11,772	90%	●	⊙					
	WB2	2000	79	4.4	5.75	5785	12,750	90%	●	●					
	WB2	2100	83	4.6	6.0	5982	13,184	90%	●	⊙					
		Maximum dynamic load pin-on (payload + bucket)							kg	12 150	11 260	10 650	9610	8860	8070
									lb	26,779	24,817	23,473	21,180	19,527	17,786
With Quick Coupler (CW-70)															
General Duty (GD)	VB2	1900	75	3.8	5.0	3668	8,084	100%			●	●	●	⊙	
Severe Duty (SD)	WB2	1900	75	4	5.25	4802	10,584	90%	●	●					
	WB2	2000	79	4.4	5.75	4959	10,930	90%	●	●					
Extreme Duty (XD)	WB2	2000	79	4.4	5.75	5797	12,777	90%	●	●					
		Maximum dynamic load with CW coupler (payload + bucket)							kg	13 470	12 580	11 970	10 930	10 180	9390
									lb	29,688	27,726	26,382	24,090	22,437	20,696

The above figures are based on maximum recommended dynamic working weights with front linkage fully extended at ground line with bucket curled. They do not exceed a stability ratio of 1.25.

Capacity based on ISO 7451.

Bucket weights include General Duty tips.

Maximum Material Density:

- 1800 kg/m³ (3,000 lb/yd³) or greater
- ⊙ 1500 kg/m³ (2,500 lb/yd³)
- 1200 kg/m³ (2,000 lb/yd³)
- ⊗ Not Recommended

Caterpillar recommends using appropriate work tools to maximize the value customers receive from our products. Use of work tools, including buckets, which are outside of Caterpillar's recommendations or specifications for weight, dimensions, flows, pressures, etc. may result in less-than-optimal performance, including but not limited to reductions in production, stability, reliability, and component durability. Improper use of a work tool resulting in sweeping, prying, twisting and/or catching of heavy loads will reduce the life of the boom and stick.

Work Tool Offering Guide*

Boom Type	Reach Boom			Mass Boom		
Stick Size	R4.67 m (15'4")	R4.15 m (13'7")	R3.6 m (11'10")	R2.84 m (9'4")	M3.0 m (9'10")	M2.57 m (8'5")
Hydraulic Hammer	H180	H180	H180	H180	H180	H180
Multi-Processor	MP40	MP40	MP40	MP40	MP40	MP40
Mobile Scrap and Demolition Shear	S365C**	S365C**	S365C**	S365C**	S365C**	S365C**
Orange Peel Grapple						
Clamshell						
Rippers						
Center-Lock Pin Grabber Coupler						
Dedicated Quick Coupler						

These work tools are available for the 374D L.
Consult your Cat dealer for proper match.

*Matches are dependent on excavator configurations. Consult your Cat dealer for proper work tool match.

**Pin-on only.

374D L Standard Equipment

Standard equipment may vary. Consult your Cat dealer for details.

ELECTRICAL

Alternator – 75 ampere
Lights
Cab interior
Cab lights, halogen, time delay
Boom lights, halogen
Signal/warning horn

ENGINE/POWER TRAIN

Automatic engine speed control
Automatic swing parking brake
Automatic travel parking brakes
Cat® C15 with ACERT® Technology
Altitude capability to 2300 m (7,500 ft)
Electric fuel priming pump
High ambient cooling capability
Side-by-side cooling system with separately mounted AC condenser and variable speed fan
Two speed travel
Water separator, with level indicator, for fuel line

GUARDS

Heavy duty bottom guards on upper frame
Heavy duty swivel guard on undercarriage
Heavy duty travel motor guards on undercarriage
Track guiding guards, center section

OPERATOR STATION

Air conditioner, heater and defroster with automatic climate control
Ashtray and 24 volt lighter
Beverage/cup holder
Coat hook
Console mounted electronic type joysticks with adjustable gain and response
Floor mat
Instrument panel and gauges with full color graphical display
Literature compartment
Neutral lever (lock out) for all controls
Positive filtered ventilation
Pressurized cab
Retractable seat belt 75 mm (3") width
Sunshade for windshield and skylight
Travel control pedals with removable hand levers
Windshield wipers and washers (upper and lower)

UNDERCARRIAGE

Double grouser 900 mm (35")
Grease lubricated track
Hydraulic track adjusters
Long, variable gauge
Steps – four

OTHER STANDARD EQUIPMENT

Auxiliary hydraulic valve for hydro-mechanical tools
Caterpillar one key security system with locks for doors, cab and fuel cap
Cat walks – left side and right side
Cross-roller type swing bearing
Drive for auxiliary pump
Hand control pattern changer
Mirrors – left and right
S·O·SSM quick sampling valves for engine oil and hydraulic oil
Steel firewall between engine and hydraulic pumps
Product Link

Optional equipment may vary. Consult your Cat dealer for details.

FRONT LINKAGE

Booms

Mass excavation 7.0 m (23'0")
with two working lights

Reach 7.8 m (25'7")
with two working lights

Sticks

M 2.57WB (8'5") for mass boom

M 3.0WB (9'10") for mass boom

R2.84VB (9'4") for reach boom

R3.6VB (11'10") for reach boom

R4.15VB (13'7") for reach boom

R4.67VB (15'4") for reach boom

Bucket Linkages

VB2-family for VB2 sticks
(available with or without lifting eye)

WB2-family for WB2 sticks
(available with or without lifting eye)

Buckets – see chart

Tips, sidecutters and edge protectors

TRACK

Double grouser 650 mm (26")

Double grouser 750 mm (30")

Double grouser 900 mm (35")

GUARDS

FOGS (Falling Object Guard System)
including overhead and windshield guards

Track guiding guards

– Full length

– Center section

Vandal guards for windshield

Wire mesh screen for windshield

AUXILIARY CONTROLS AND LINES

Basic control arrangements

Single action – one-way high pressure
for hammer application

Combined function – one-way high pressure
circuit for hammer application function for
one-way or two-way high pressure.

Quick coupler circuit

Quick coupler lines for booms

Quick coupler lines for sticks

Auxiliary boom lines

High pressure for reach and mass booms

Auxiliary stick lines

High pressure lines for reach
and mass sticks

MISCELLANEOUS OPTIONS

Adjustable high-back heated seat
with mechanical suspension

Adjustable high-back seat
with air suspension and heater

Boom lowering control device

Counterweight removal system

Starting aid for cold weather with ether

Stick lowering control device

Straight travel pedal

Cab front rain protector

Converter, 10 amp – 12 volt
with two sockets

HID, boom lights

HID, cab lights, time delay

Jump start terminals

Reversible cooling fan including
protective screen

Operator Compartment

Joysticks

Four button joystick for standard machine
or single action auxiliary control

Thumb wheel modulation joystick
for use with combined auxiliary control

Lunch box storage with lid

Radio

AM/FM radio mounted in right hand
console with antenna and two speakers

Radio ready mounting at rear location
including 24 volt to 12 volt converter
speakers, antenna

Two-way radio ready

WAVES ready

374D L Hydraulic Excavator

For more complete information on Cat products, dealer services, and industry solutions, visit us on the web at www.cat.com

© 2013 Caterpillar Inc.
All rights reserved

Materials and specifications are subject to change without notice. Featured machines in photos may include additional equipment. See your Cat dealer for available options.

CAT, CATERPILLAR, SAFETY.CAT.COM, their respective logos, "Caterpillar Yellow" and the "Power Edge" trade dress, as well as corporate and product identity used herein, are trademarks of Caterpillar and may not be used without permission.

AEHQ6064-02 (01-2013)
Replaces AEHQ6064-01
(NACD, LACD)

