

793D

Mining Truck



Engine

Engine Model	Cat [®] 3516B HD EUI	
Gross Power – SAE J1995	1801 kW	2,415 hp
Net Power – SAE J1349	1743 kW	2,337 hp

Weights – Approximate

Gross Machine Operating Weight	383 749 kg	846,000 lb
--------------------------------	------------	------------

Operating Specifications

Nominal Payload Capacity	218 tonnes	240 tons
Body Capacity – Dual Slope		
Struck	96 m ³	126 yd ³
Heaped (SAE 2:1)	129 m ³	169 yd ³

793D Mining Truck

Engineered for performance, designed for comfort, built to last.

Power Train – Engine

The Cat® 3516B High Displacement EUI engine delivers the power and reliability necessary to perform in the most demanding applications. Designed for efficient operation, the 3516B offers excellent fuel efficiency, lower emissions, reduced engine noise and lower operating costs. **pg. 4**

Power Train – Merchandising Arrangements

The 793D is available in four different normal altitude configurations and one arrangement for high altitude operations. All configurations include key components matched to performance requirements in specific applications and conditions. **pg. 5**

Power Train – Transmission

The Cat six-speed power shift transmission and mechanical power train, matched with the electronic unit injection 3516B high displacement engine, provides consistent power and efficiency for peak power train performance. **pg. 6**

Operator's Station

The ergonomic cab is designed for operator comfort and ease of operation to allow the operator to focus on production. Controls and gauges are positioned within easy reach for optimum efficiency and superior control. **pg. 12**

Serviceability

The 793D is designed for quick and easy servicing. Simplified service and maintenance features reduce downtime, allowing the machine to spend less time being serviced and more time on the haul roads. **pg. 13**

Monitoring System

VIMS® monitoring system provides operators, service technicians and mine personnel with vital machine health and payload data to keep the 793D performing at peak efficiency and top production levels while lowering cost-per-ton. **pg. 14**

The 793D Mining Truck is available in five merchandising arrangements:

- **Standard** – for balanced all-around performance
- **Extended Life Wheel Groups** – for long, uphill hauls
- **Extra Top Speed** – for long, flat hauls
- **Extra Retarding** – for long, downhill loaded hauls
- **High Altitude Arrangement** – for operations above 2750 m (9,000 ft)



Structures

Caterpillar® truck frames are built to optimize torsional load displacement. Mild steel provides flexibility, durability and resistance to impact loads. Castings and forgings in high stress areas provide exceptional strength and durability for long life. **pg. 7**

Engine/Power Train Integration

The Cat Data Link electronically combines engine, transmission, brake and operational information to optimize overall truck performance. Stored diagnostic data can be accessed via the Electronic Technician (Cat ET) to improve troubleshooting and reduce downtime. **pg. 8**

Caterpillar Brake System

Cat oil-cooled, multiple disc brakes offer exceptional, fade-resistant braking and retarding for maximum performance and productivity in all haul road conditions. Integrated Braking Control combines retarding and traction control into one system for optimum braking efficiency. **pg. 10**

Truck Body Systems

A variety of Caterpillar designed and built truck bodies ensure optimal performance and reliability in tough mining applications. Cat dealers can help build an optimum hauling system to maximize truck payloads and extend body and truck wear life. **pg. 16**

Customer Support

Caterpillar dealers provide unmatched product support, anywhere in the world. With industry-best parts availability and a wide range of maintenance and service options, Cat dealers have what it takes to keep your mining machines productive. **pg. 18**

Safety

Caterpillar sets the standard when it comes to safety in the design and manufacturing of heavy equipment for the mining industry. Safety is not an afterthought at Caterpillar, but an integral part of all machine and systems designs. **pg. 19**



Power Train – Engine

The Cat 3516B High Displacement engine is built for power, reliability and efficiency for superior performance in the toughest applications.

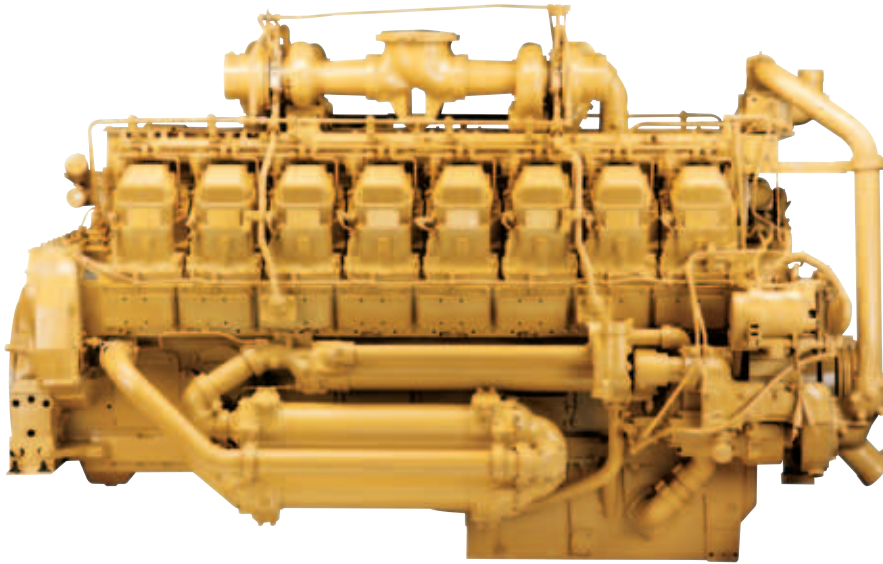

Engine. The Cat 3516B High Displacement EUI quad turbocharged and aftercooled diesel engine produces 5% greater power with enhanced power management capability for maximum hauling performance in the most demanding mining applications.

Design. The 3516B is a 16-cylinder, four-stroke design that uses long, effective power strokes for more complete fuel combustion and optimum efficiency.

EPA Compliant. The Cat 3516B High Displacement engine is compliant with U.S. Environmental Protection Agency Tier I emissions standards.

Altitude Compensation. Designed for maximum operating efficiencies at altitudes under 2750 m (9,000 ft).

High Altitude Arrangement (HAA). The optional Cat 3516B quad and series turbocharged aftercooled short stroke engine provides full power with no deration at altitudes greater than 2750 m (9,000 ft).

High Torque Rise. The 23% net torque rise provides unequalled lugging force during acceleration, on steep grades and in rough underfoot conditions. Torque rise effectively matches transmission shift points for maximum efficiency and fast cycle times.

Enhanced Life. High displacement, low rpm rating and conservative horsepower ratings mean more time on the haul roads and less time in the shop.

Single-Piece Piston Design. New single-piece forged steel pistons with integrated forged steel skirt are more robust to withstand high engine heat and pressure and enable enhanced combustion efficiency, improved fuel efficiency and lower emissions. Corrosion resistant, stainless steel top ring reduces ring, groove and liner wear for greater reliability and longer life.

Electronic Unit Injection (EUI).

The electronically controlled unit injection fuel system senses operating conditions and regulates fuel delivery for optimum fuel efficiency. The proven high-pressure fuel system provides improved response times and more efficient fuel burn with lower emissions and less smoke.

Electronic Control Module (ECM).

ECM utilizes advanced engine management software to monitor, control and protect the engine utilizing self-diagnosing electronic sensors. The computerized system senses operating conditions and power requirements and adjusts engine for peak performance and most efficient operation and at all times.

Separate Circuit Aftercooler.

Allows the aftercooler circuit to operate cooler than jacket water temperature for a denser air charge and greater combustion efficiency.

Cooling System.

The new Mesabi radiator offers the addition of long life, higher durability and easier serviceability. The fan is hydraulically driven for more efficient cooling with lower fuel consumption and noise levels.

Oil Renewal System. Optional oil renewal system extends engine oil change intervals from 500 hours to 4,000 hours or more to increase machine availability and reduces costs.

Engine Protection. Computerized system electronically protects the engine during cold starts, high altitude operation, air filter plugging, and high exhaust temperature.

Power Train – Merchandising Arrangements

Five configurations are performance matched to meet specific applications and conditions.

Merchandising Arrangements.

The 793D is available in four different normal altitude configurations, and a high altitude arrangement. All configurations deliver increased speed on grade and include key components that are performance matched to the hauling application and site conditions.



Standard Arrangement.

The standard arrangement is designed for exceptional, all-around performance. Three factors combine to produce up to 9% more power at the wheels than the 793C, including: 5% more engine horsepower; a common rail hydraulic system for greater power train efficiency; and a hydraulically driven demand fan that reduces parasitic load by operating only when needed. More power at the wheels reduces cycle times and lowers cost-per-ton.



Extended Life Wheel Groups.

Developed for uphill hauling applications, this arrangement is designed to extend wheel life and hauling performance on long uphill hauls. Extended life wheel groups are built with larger, more durable components, including larger spindles, wider wheel bearing spacing, a larger braking surface, and extended life friction disc material for longer brake life and more time between overhauls.



Extra Top Speed.

Developed for long, flat haul applications, the extra top speed configuration delivers a 10% increase in maximum speed to 60 km/h (37 mph) via a new input transfer gear group. This arrangement also includes Extended Life Wheel Groups.



Extra Retarding.

Developed for downhill loaded applications, this configuration typically delivers an extra gear of retarding capability of 35% more speed on downhill grades. Extra retarding is achieved by adding more robust wheel groups, larger brakes, extended life friction material, and additional cooling capacity.



High Altitude Arrangement.

Developed for high altitude applications, the 3516B short stroke engine delivers enhanced power management at higher altitudes – from 2750 to 1600 m (9,000 to 12,000 ft). This arrangement also includes Extra Retarding.

Power Train – Transmission

Cat mechanical power train delivers more power to the ground for greater productivity and lower operating costs.



Mechanical Power Train. The Cat mechanical drive power train and power shift transmission provides unmatched operating efficiency and control on steep grades, in poor underfoot conditions, and on haul roads with high rolling resistance.

1) Transmission. The Cat six-speed planetary power shift transmission is matched with the direct-injection 3516B HD diesel engine to deliver constant power over a wide range of operating speeds.

• Robust Design. Designed for the higher horsepower of the 3516B HD engine, the proven planetary power shift transmission is built tough for long life between overhauls.

• Long Life. A dedicated oil tank and circuit provides cooler, cleaner oil for maximum performance and longer component life.

• Transmission Chassis Control (TCC). TCC uses electronically transferred engine rpm data to execute shifts at preset points for optimum performance, efficiency and clutch life.

2) Lock-Up Torque Converter. Combines maximum rimpull and cushioned shifting of torque converter drive with the efficiency and performance of direct drive. The lock-up torque converter engages at approximately 8 km/h (5 mph), delivering more power to the wheels.

• Lock-Up Clutch. Quickly releases and re-engages to reduce power train torque loads for smoother shifting, long life and a more comfortable ride.

• Smooth Shifting. Individual clutch modulation provides smooth clutch engagements to optimize performance and extend clutch life.

3) Final Drives. Cat final drives work as a system with the planetary power shift transmission to deliver maximum power to the ground. Built to withstand the forces of high torque and impact loads, double reduction final drives provide high torque multiplication to further reduce drive train stress.

• Rear Axle Filtration. A new filtration system provides cooler, cleaner oil for longer component life.

• Steering System. Hydraulic steering control system is designed for exceptional smoothness and precise control. A separate circuit prevents cross contamination for long life.

• Supplemental Steering.

Supplemental steering system uses pressure accumulators and allows up to three 90 degree turns in case of engine failure.

• Wheels and Rims. Cast rear wheels and Cat center-mount rims are mounted using studs and nuts to minimize maintenance and maximize durability.

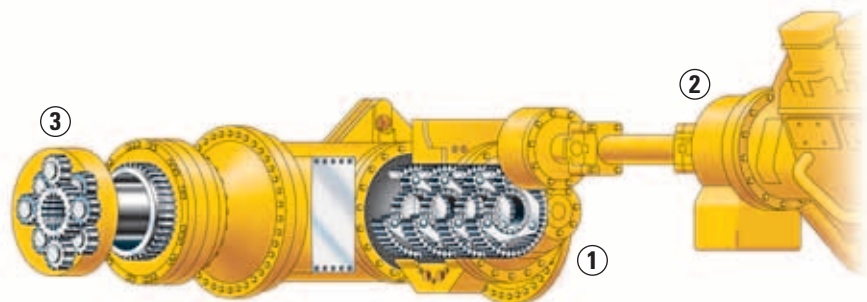

Structures

Rugged Cat structures are the backbone of the 793D mining truck's durability.

Box-Section Design. The 793D frame uses a box-section design, incorporating two forgings and 24 castings in high stress areas with deep penetrating and continuous wrap-around welds to resist damage from twisting loads without adding extra weight.

• **Steel Structures.** Mild steel used throughout frame provides flexibility, durability and resistance to impact loads, even in cold climates, and allows for easy field repairs.

• **Castings.** Castings have large radii with internal reinforcing ribs to dissipate stress in areas of high stress concentration. Castings move welds to lower stress areas for greater frame life.

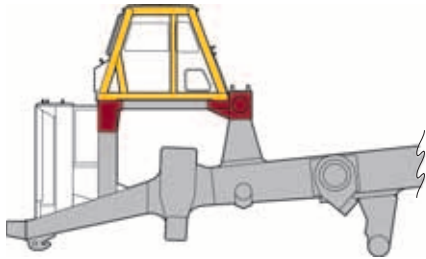

Integral Four-Post ROPS Cab.

Resiliently mounted to the main frame to reduce vibration and sound, the integral ROPS is designed as an extension of the truck frame. The ROPS/FOPS structure provides “five sided protection” for the operator.

Suspension System. Designed to dissipate haul road and loading impacts for longer frame life and a more comfortable ride.

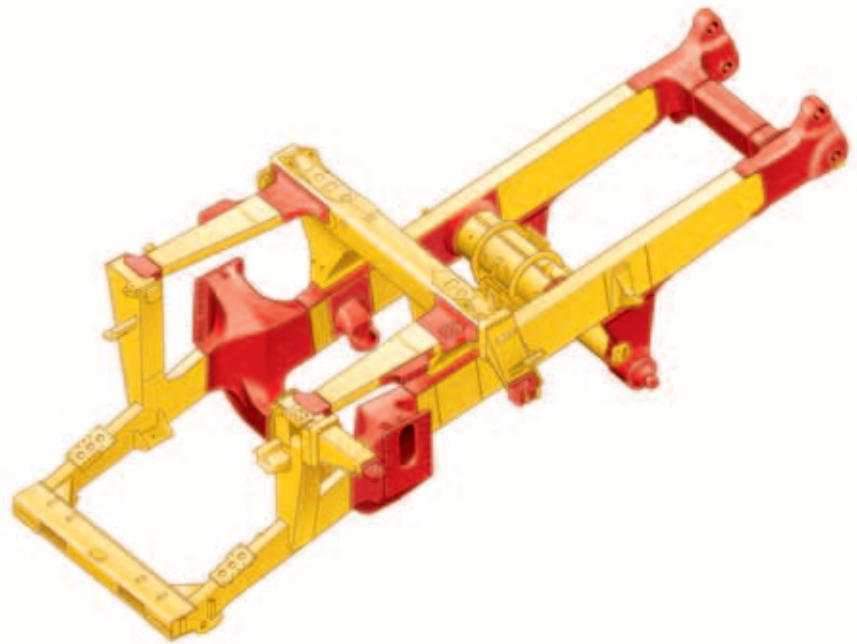

• **Cylinders.** Four independent self-contained, oil pneumatic, variable-rebound suspension cylinders are designed to absorb shocks in the most severe applications.

• **Durable Design.** Rugged cylinders utilize large diameter bore and low pressure nitrogen/oil design for long life with minimal maintenance.

– **Front.** Front cylinders with preset caster and camber are mounted to the frame and serve as steering kingpins for a tight turning radius with excellent maneuverability and low maintenance.

– **Rear.** Rear cylinders allow axle oscillation and absorb bending and twisting stresses caused by uneven and rough haul roads rather than transmitting them to the main frame.

Engine/Power Train Integration

Electronically combines critical power train components to work more intelligently and optimize overall truck performance.

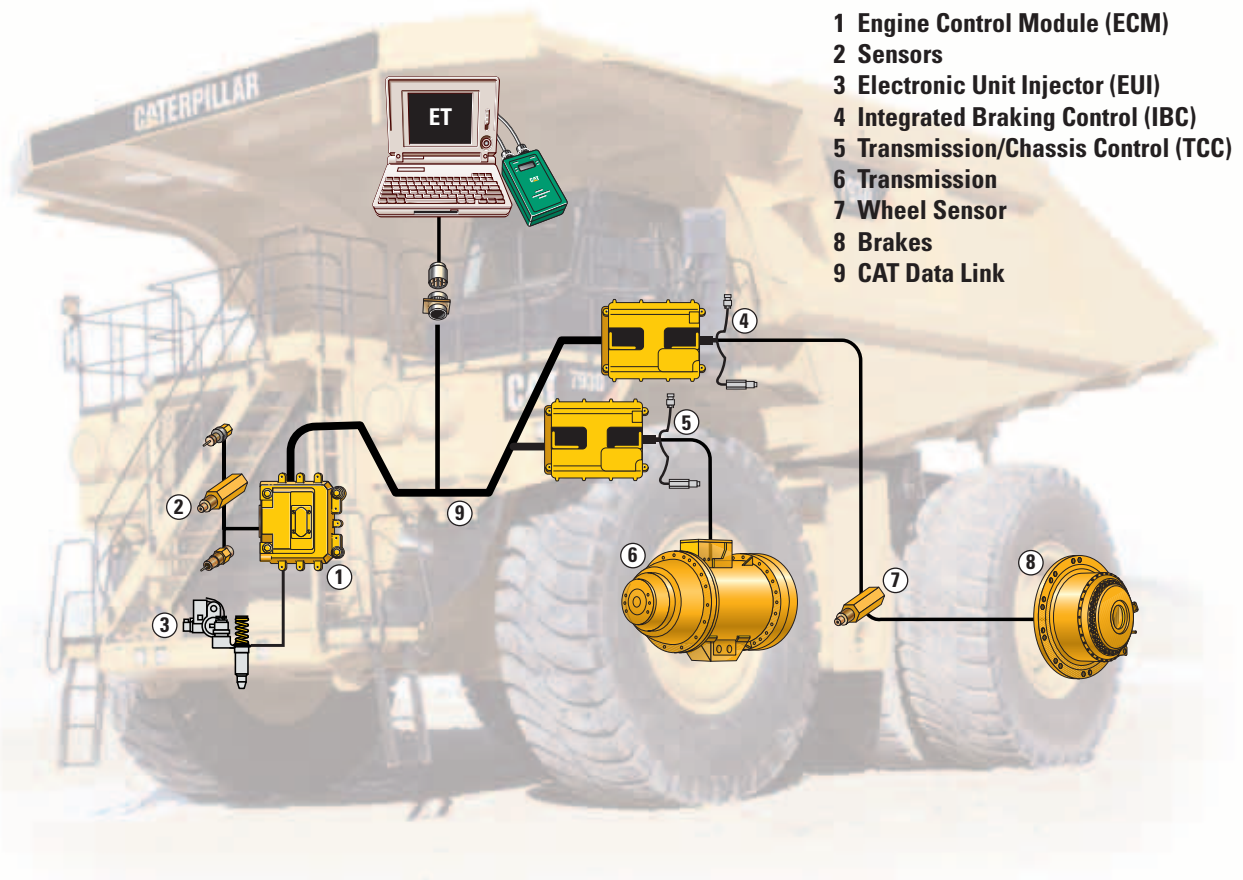

Cat Data Link. Electronically integrates machine computer systems to optimize overall power train performance, increase reliability and component life, and reduce operating costs.

Controlled Throttle Shifting. Regulates engine rpm during shifting to reduce power train stress and clutch wear by controlling engine speed, torque converter lock-up and transmission clutch engagement for smoother shifts and longer component life.

Directional Shift Management.

Regulates engine speed during directional shifts to prevent damage caused by high speed directional changes.

Neutral Coast Inhibitor. Prevents transmission from shifting to neutral at speeds above 6.5 km/h (4 mph) to protect the transmission from operating with insufficient lubrication.

Body-up Reverse Neutralizer.

Automatically shifts the transmission to neutral if the hoist lever is activated while transmission is shifted in reverse.

Body-up Shift Inhibitor. Prevents the transmission from shifting above the pre-programmed gear without the body fully lowered.

Overspeed Protection. The transmission control electronically senses engine conditions and automatically up-shifts one gear to prevent overspeeding. If overspeeding occurs in top gear, the lock-up clutch is disengaged.

Programmable Top Gear. Transmission top gear maximum can be set using the Cat ET service tool to help the operator maintain speed limits.

Anti-Hunt Function. Minimizes shifting by not allowing the transmission to up or down shift immediately after a shift has occurred. This prevents gear hunting when operating near a shift point and minimizes transmission shifting for increased component life.

Downshift Inhibitor. Prevents engine overspeeding by keeping the transmission from downshifting until engine speed reaches the downshift point.

Electronic Technician (Cat ET). Cat ET service tool provides service technicians with easy access to stored diagnostic data through the Cat Data Link to simplify problem diagnosis and increase machine availability.

Diagnostic Capability. Critical data from the electronic engine and transmission controls, including transmission shifting, engine speed and fuel consumption, provides service technicians with enhanced diagnostic capability to reduce downtime and operating costs.

Integrated Braking Control (IBC). IBC integrates Hydraulic Automatic Retarder Control and Traction Control into one system for optimum performance and efficiency.

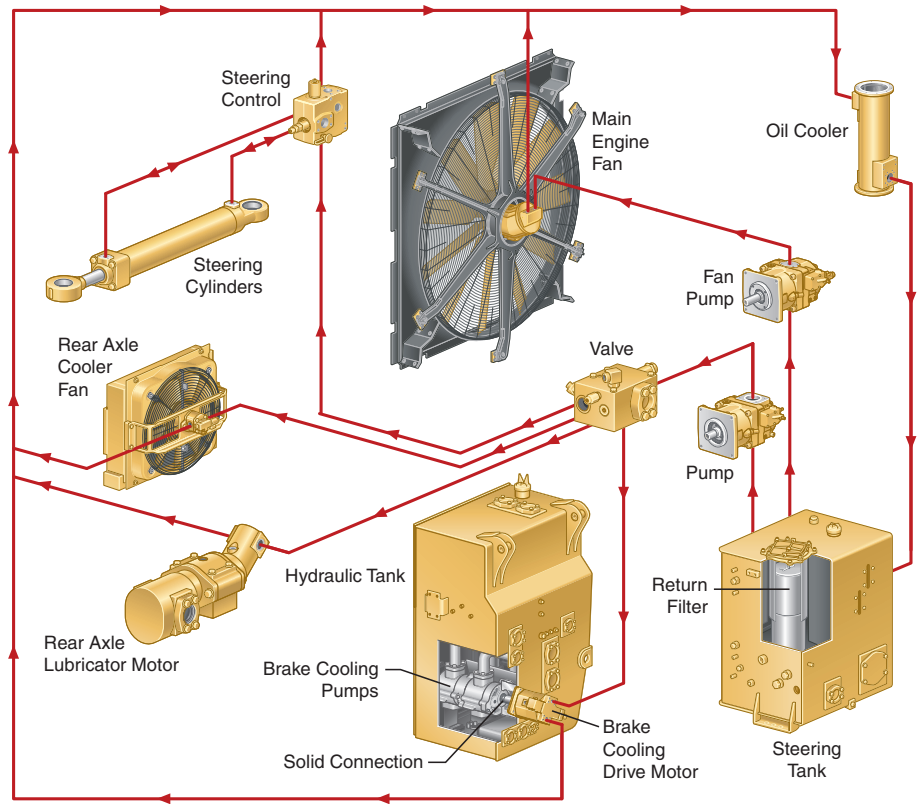

Hydraulic Power Management System

Hydraulic Power Management System. The system, also known as common rail hydraulics, reduces parasitic (unused, wasted) losses in the power management system components and the new hydraulic fan drive system. The system is operated by two new variable displacement piston pumps. These pumps primarily provide for the steering and cooling functions, and are independent of the brake and hoist circuit. One pump is dedicated to a new on-demand hydraulic fan drive system.

The other pump feeds a new priority valve and provides hydraulic pressure and flow to feed steering, brake cooling, rear axle filtration (RAX), and the optional RAX cooler systems. The system continues to allow priority for the steering system while using an improved power management scheme for brake cooling and RAX functions. By reducing the losses, the system is able to provide more horsepower to the ground.

Caterpillar Brake System

Reliable braking with superior control gives the operator the confidence to focus on productivity.



Integrated Braking System. The Cat oil-cooled braking system delivers reliable performance and control in the most extreme haul road conditions. The integrated system combines the service, secondary, parking brake and retarding functions in the same robust system for optimum braking efficiency.

Cat Data Link. All control modules communicate via the Cat Data Link and work together as an integrated system to maximize production efficiency and extend component life.

Oil-Cooled Multiple Disc Brakes. Caterpillar four-wheel, forced oil-cooled, multiple disc service brakes are continuously cooled by water-to-oil heat exchangers for exceptional, non-fade braking and retarding performance.

Extended Life Disc Brakes. Extended life friction material has double the wear life of standard brakes and is twice as resistant to glazing for more consistent braking power with less noise.

Brake Design. Cat oil-cooled disc brakes are designed with large discs and plates for reliable, adjustment-free operation and performance. Brakes are completely enclosed and sealed to prevent contamination and reduce maintenance.

Long Life. An oil film prevents direct contact between the discs. This design absorbs the braking forces by shearing the oil molecules and carrying heat away to extend brake life.

Pistons. The Caterpillar two-piece piston design combines the service, secondary, parking brake and retarding functions in the same system. The primary piston hydraulically actuates both service and retarding functions. The secondary piston is spring-applied and held in the disengaged position by hydraulic pressure. If hydraulic system pressure drops below a specified level, the spring-applied secondary piston automatically applies the brakes.

Parking Brake. Oil-cooled, spring-applied, hydraulically released parking brake is applied to all four wheels for superior parking capability on all grades up to 15 percent.

Hydraulic Automatic Retarder Control (HARC). Hydraulically activated automatic retarder control system electronically controls retarding on grade to maintain optimum engine rpm and oil cooling. Additional braking may be applied using the manual retarder or the brake pedal. HARC is deactivated when the operator applies the brake or accelerator controls.

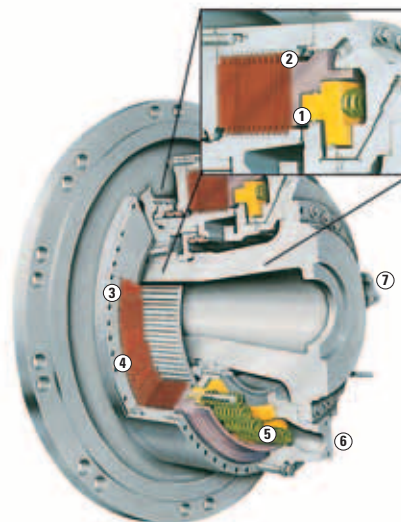

- 1 Parking/Secondary Piston
- 2 Service/Retarding Piston
- 3 Friction Discs
- 4 Steel Plates
- 5 Actuating Springs
- 6 Cooling Oil In
- 7 Cooling Oil Out

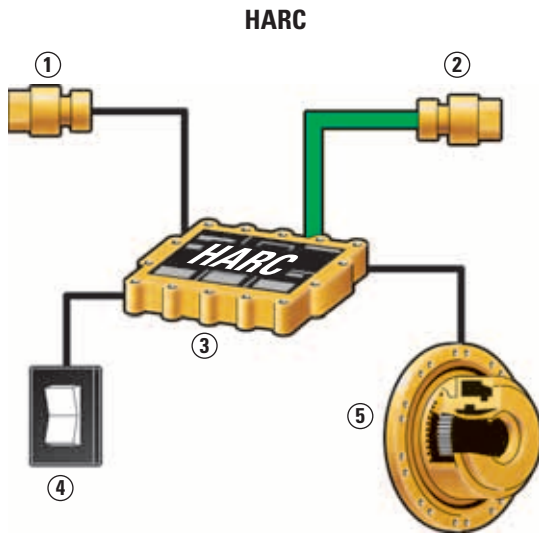

- 1 Service Brake Sensor
- 2 Engine Sensor
- 3 HARC
- 4 HARC Switch
- 5 Brakes
- 6 Service Brakes
- 7 Axle Speed Sensor
- 8 TCS

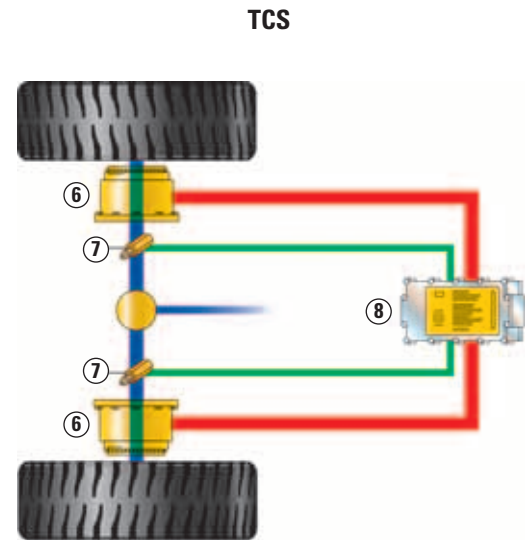

HARC vs. ARC.

- Less chance for engine overspeed
- Smoother engagement
- No loping
- Less air system demand
- Reduces operating costs

HARC Production Advantages.

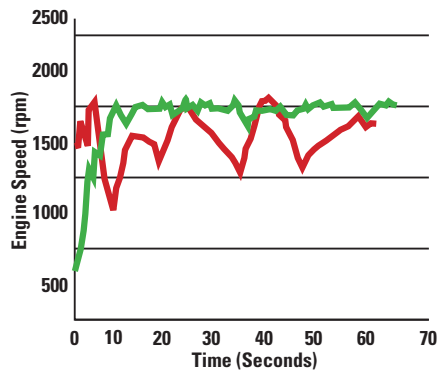

- With Hydraulic Automatic Retarder Control (average speed, 1950 rpm)
- With Manual Retarder Control (average speed, 1730 rpm)

Faster Speeds. HARC allows the operator to maintain optimum engine speeds for faster downhill hauls and greater productivity.

Superior Control. Automatic brake modulation offers a smoother ride and better control in slippery conditions, allowing the operator to concentrate on driving.

Ease of Operation. HARC increases operating ease, resulting in greater operator confidence with less fatigue.

Engine Overspeed Protection. Automatically activates HARC when engine speed exceeds factory preset levels, regardless of operator inputs, to avoid potentially damaging engine overspeeds.

Four Corner Retarding. Four corner retarding with 60/40 percent split (rear/front) in braking effort provides superior control in slippery conditions. Balanced front to rear brake torque provides exceptional braking performance and minimizes wheel lock-up, especially during retarding.

Traction Control System (TCS).

Electronically monitors and controls rear wheel slippage for greater traction and enhanced truck performance in poor underfoot conditions. If slippage exceeds a set limit, the oil-cooled disc brakes engage to slow the spinning wheel. Torque is then automatically transferred to the wheel with better traction.

Differential Action. Normal differential action provides superior maneuvering and control in slippery conditions.

Integrated Braking Control (IBC). Combines Hydraulic Automatic Retarder Control (HARC) and Traction Control System (TCS) into one integrated brake control system for optimum efficiency, performance and reliability.

Fuel Efficiency. The engine provides additional retarding by running against compression on downhill hauls. During retarding applications the engine ECM does not inject fuel into the cylinders for exceptional fuel economy.

Operator's Station

Ergonomically designed for operator comfort, superior control and high productivity.



Ergonomic Layout. The 793D operator station is ergonomically designed for total machine control in a comfortable, productive and safe environment. All controls, levers, switches and gauges are positioned to maximize productivity and minimize operator fatigue.

Quiet Cab. Integral, sound-suppressed ROPS/FOPS cab is resiliently mounted to the mainframe to isolate the operator from sound and vibration for a quiet, secure and comfortable ride.

Viewing Area. Designed for excellent all-around visibility and clear sight lines to the haul road, the large viewing area enables the operator to maneuver with confidence for high productivity.

1) Air Suspension Seat w/ Three-Point Operator Restraint. Ergonomically designed, fully adjustable air suspension seat with adjustable armrests provides

optimal driving comfort. A wide, retractable 3-point seat/shoulder belt provides a secure, comfortable restraint.

2) Hoist Lever. Four-position, low effort electronic hoist control system with fingertip control is mounted next to the operator's seat for ease of operation.

3) Secondary Brake Pedal. Conveniently located on the floor for easy operator control.



4) Monitoring System. The VIMS system features an easy-to-read display and easy-to-use operator input keypad for precise machine status information.

5) Steering Column. Comfort wheel with tilt and telescoping steering provides a comfortable driving position.

6) Transmission Console. Ergonomic gear shift lever with backlit gear indicators optimize efficiency.

7) Parking Brake Reset Valve. Parking brake cannot be released when air system is drained until valve button is reset.

8) Storage Compartment. Located under the trainer seat for a safe, uncluttered working environment.

9) Trainer Seat. Full-size, fully padded trainer seat features a backrest, wide hip and shoulder room, and seat belt for secure travel. Air suspension, optional.

10) Operator Window. Powered operator window and sliding trainer seat window offer simple operation and an unobstructed view.

11) Operator Controls. Easy to reach reach turn signal, high beam, intermittent windshield wiper and windshield washer controls are designed for optimum efficiency and comfort.

12) Heating/Air Conditioning. Electronically controlled four-speed fan and eleven vents deliver temperature-controlled air circulation for a comfortable working environment in any climate. More robust air compressor offers greater durability and longer life.

Communication Systems Ready. Cab is prewired with power converter, speakers, wiring harness, antenna and mounting locations for add-on radio, closed circuit TV, and MineStar® systems.

Serviceability

Less time spent on maintenance means more time on the haul roads.

Servicing Ease. Easy access to daily service points simplifies servicing and reduces time spent on regular maintenance procedures. Enhanced serviceability and 500-hour service intervals are designed to increase machine availability and productivity.

Maintenance Platform. Provides access to engine, air filters, steering hydraulic tank and battery compartment.

In-Frame Access. Permits easy access to major components for easy servicing and removal.

Ground-Level Access. Allows convenient servicing to tanks, filters, drains, and engine shutdown. Ground-level VIMS data port permits easier downloading of information.

Transmission Lockout Switch. Ground level transmission lockout switch allows the truck to be serviced with the engine running, without the risk of accidental motion.

Autolube. Automatic lubrication system reduces maintenance time by automatically lubricating necessary components on a regular basis.

Fast Fill Service Center. Optional Wiggins fast fill service center features high speed fuel and oil exchange.

Oil Renewal System (ORS). Optional on-board engine oil management system is designed to increase availability and productivity by extending oil change intervals and reduce oil disposal labor and costs. ORS meters and injects used engine oil from the crankcase into the engine's fuel return line. New oil is manually added as a part of daily maintenance.

Scheduled Oil Sampling. S•O•SSM sampling valves speed sampling and analysis reliability.



Pressure Test Points. Disconnect valves are conveniently located throughout the hydraulic systems for easy pressure testing.

Air Filters. Radial seal air filters are easy to change, reducing time required for air filter maintenance.

Sealed Electrical Connectors. Electrical connectors are sealed to lock out dust and moisture. Harnesses are braided for protection. Wires are color coded for easy diagnosis and repair.

Cylinder Heads. Individual cylinder heads are interchangeable for easy removal and visual inspection of internal parts.

On-Board Diagnostic Systems.

The VIMS system continuously checks all critical machine functions and components, and helps locate faults quickly for faster repair. Electronic control system enables quick diagnosis of engine conditions and effective maintenance and repairs utilizing the Electronic Technician (Cat ET) service tool.

Mirrors. The left side mirror mounting bracket is more robust and allows mirror glass to be easily replaced, without the need for a new mirror assembly. New mirror glass slides in and out of the carrier, reducing downtime and maintenance costs.

Monitoring System

Vital machine health and payload data keeps the 793D performing at peak production levels.

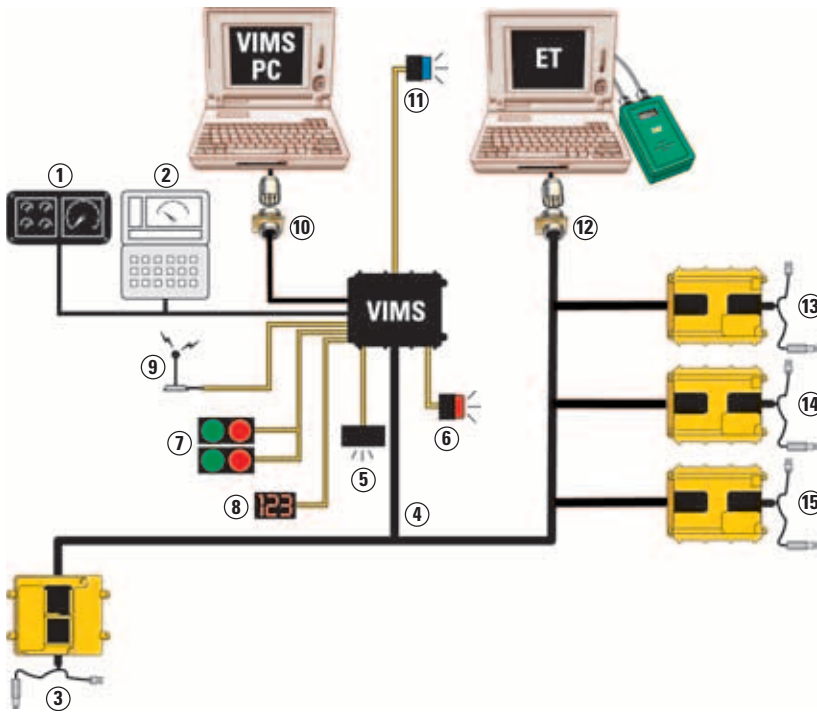

- 1 Gauge Cluster
- 2 Message Center and Keypad
- 3 ADEM III Engine Control Module
- 4 CAT Data Link
- 5 Action Alarm
- 6 Action Lamp
- 7 Payload Lamps
- 8 Payload Display (optional)
- 9 Radio System (optional)
- 10 Data Port (VIMS-PC)
- 11 Service Lamp
- 12 Diagnostic Connector (ET)
- 13 Integrated Brake Control (IBC) and Cooling Fan Control Module
- 14 Transmission/Chassis Control (TCC) Module
- 15 Road Analysis Control (RAC) Module (optional)

VIMS® Monitoring System. Intelligent Caterpillar designed machine monitoring system provides critical machine health and payload data in real-time to keep the 793D performing at top production levels.

Integrated System Monitoring.

Sensors located throughout the machine systems enable the VIMS system to quickly exchange and monitor information from all machine systems for efficient, high performance operation.

Advanced Diagnostics. VIMS system simplifies troubleshooting, reduces downtime and lowers operating costs by identifying abnormal conditions before they cause extensive damage.

Data Access. Monitoring and diagnostic information is stored on-board until it can be downloaded for analysis. Data can be accessed through the message center, transmitted via optional radio or downloaded onto a computer for detailed analysis.

Machine Management. Service technicians or mine personnel can download data and generate reports for better machine management. Data can be used to improve effectiveness of scheduled maintenance programs, maximize component life, improve machine availability, and lower operating costs.



Speedometer/Tachometer Module.

Monitors three systems: engine speed, ground speed and gear indicator.



Gauge Cluster. Conveniently located gauge cluster maintains a constant display of vital machine functions, including:

- engine coolant temperature
- brake oil temperature
- air system pressure
- fuel level



Keypad. Provides operator or service technician immediate access to current machine information, gauge values and stored data through the message center display.

Message Center. Displays messages requested by operator and advises operator of abnormal machine conditions.

Alert System. Three-category warning system alerts operator of abnormal machine health conditions.

- **Category I.** Machine or system needs attention.
- **Category II.** Requires operator to evaluate and correct situation before continuing work.
- **Category III.** Immediate shutdown required to prevent serious damage to machine or system.

Production Management. Production Management enhances truck/loading tool effectiveness, improves fleet productivity and helps extend the life of truck frames, tires, rims and power train components, while lowering operating and maintenance cost.

Payload Management. Max Payload Speed Manager is a feature that aids in managing the Caterpillar 10/10/20 Overload Policy. Based on target payload weight and overload settings, the VIMS system logs and warns the operator when the truck reaches overload after 2nd gear reweigh. The truck will be limited to 2nd gear at 1,750 rpm, and the automatic retarder speed setting is reduced to 1,750 rpm until the load is dumped.

Payload management enables the manager to enhance truck/loading tool effectiveness and productivity levels by preventing overloads that can cause damage to component life and affect operator safety.

The Payload Weight Distribution chart illustrates the benefit of managing payloads with VIMS production management tools.

Data Storage. The VIMS system stores payload information, which is used to manage production. The system stores up to 2,400 production cycles for a complete record of payload weight, cycle times, distances and actual dates/times. It also allows storage of maintenance data such as Events, Trends, Histograms, Cumulatives, Snapshot and Dataloggers. This data allows the user

to identify potential problems before they occur, utilizing the efficiency of Preventative Maintenance.

External Payload Indicators. External lights on both sides of the truck signals loading tool operator when to cease loading for optimum payloads without overloading. Optional external payload display with digital numeric monitor are available to replace the standard red/green indicator lamps.

Road Analysis Control (RAC). Optional system monitors haul road conditions by measuring frame rack and pitch to improve haul road maintenance, cycle times, tire life and fuel efficiency.

VIMS-PC. VIMS-PC, the off-board reporting software program, allows service personnel to download a complete record of machine health and productivity data to a laptop computer for diagnosis and analysis. Easy-to-use software enables service technicians and mine personnel to generate health and payload reports for more effective machine management.

VIMS Supervisor. Optional software allows mine personnel to easily manage and interpret VIMS data for optimum fleet management and productivity.

Payload Weight Distribution

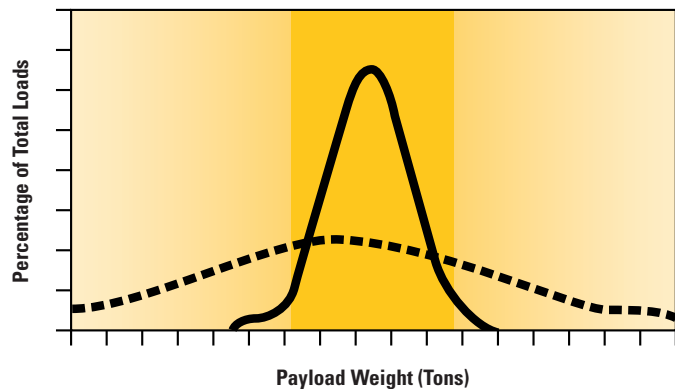

- Recommended Payload Range
- Inefficient Payload Ranges
- With Production Management
- Without Production Management

Truck Body Systems

Cat designed and built for rugged performance and reliability in the toughest mining applications.



Cat Truck Bodies. Caterpillar offers three specific body styles and custom body options to help customers obtain the lowest cost-per-ton hauling solution.

- Dual-Slope
- Flat Floor
- Mine Specific Design (MSD II)

Body Selection. Selection of the right body depends on material and haul road conditions. The better the match of body to application, the greater the efficiency. Your Cat dealer can help you select the right body system for your site specific applications.

Body/Chassis Integration. Caterpillar truck bodies are designed and matched with the integrated chassis system for optimum structural reliability, durability and long life.

Electronic Hoist Control. Provides the operator with better control of the load when dumping, including over-center load control and modulated control throughout the operating range. The automatic body snubbing feature reduces impact on the frame, hoist cylinders and operator.

Fast Hoist Cycle Times. Two-stage hoist cylinders provide fast dump cycle times of 20.25 seconds for raise and 17.5 seconds for lower.

Body Liners. A variety of liner options are available to save weight and extend the body system's life. Wear surfaces and liners are equipped to handle tough impact loads while resisting abrasion. Wear plates deliver long life in high wear areas. Modular liner plate packages:

- Smooth plate
- Rock box
- Zipper grid
- Mechanically Attached Wear Plate System (MAWPS)

Custom Body Options. Tail extensions, sideboards, tumblebars, rock boxes and rock shedders are available to maintain rated payload, reduce spillage, and improve hauling efficiencies.

- Sideboards are designed to maximize or attain gross machine weight.
- Tail extensions are used to help retain the rear portion of the pile and limit load spillage on haul roads, extending tire life.

Body Design. Cat truck bodies are designed for optimal strength, capacity and durability. Wear surfaces are equipped to handle even the toughest impact and abrasion over the long haul without diminishing capacity.

- Five-Sided Beams tie in the sidewall and floor junctions add increased body rigidity and strength.
- Wide Ribs in body floor provide increased durability and impact support.
- Full-Length Stringers create strength and rigidity throughout the bed.
- Box Section Beams offer increased durability in the floor, sidewall, top rail, corner, and cab canopy areas.



1) Dual-Slope Body. The dual-slope body design with V-shaped floor provides excellent load retention, maintains a low center of gravity, reduces shock loading, and maintains optimum load distribution on steep inclines and in challenging haul road conditions.

- Reinforced, rolled steel top rail increases body strength and protects the body from damage caused by the loading tool or falling material
- 8 degree “V” reduces shock loading and centers the load.
- 7.5 degree forward body slope and 16 degree ducktail slope helps retain loads on steep grades.



2) Flat Floor Body. The flat floor design with slight incline delivers excellent payload capacity, high dump clearances and smooth, controlled dumping.

- Flat floor design provides consistent wear characteristics on body tail.
- 12 degree forward body slope provides good load retention on better maintained haul roads.
- 400 Brinell steel on surfaces provides excellent wear.



3) Mine Specific Design (MSD II) Body. The lightweight MSD II body is based on the flat floor design and is customized to maximize payload potential and minimize cost-per-ton. Each MSD II body design begins with a detailed mine site profile to develop a body suitable for a mine’s individual needs.



Target Payload Strategy. Your Caterpillar Dealer can help you manage to target payload to maximize equipment utilization, ensure safe operation, increase productivity and lower cost-per-ton.

- Underloading increases costs due to lost payloads, underutilizes equipment, and drives cost-per-ton.
- Overloading or surpassing maximum gross machine weight, causes excessive wear on vehicle components such as brakes, tires and drivetrain, reducing component life and increasing maintenance costs and repairs.

Customer Support

Caterpillar dealers have what it takes to keep mining haul trucks productive.



Commitment Makes the Difference.

Cat dealers offer a wide range of solutions, services and products that help you lower costs, enhance productivity and manage your operation more efficiently. Support goes far beyond parts and service. From the time you select a piece of Cat equipment until the day you rebuild, trade or sell it, the support you get from your Cat dealer makes the difference that counts.

Dealer Capability. Cat dealers will provide the level of support you need, on a global scale. Dealer expert technicians have the knowledge, experience, training and tooling necessary to handle your repair and maintenance needs, when and where you need them.

Product Support. Cat dealers believe superior products deserve superior support. When Cat products reach the field, they are supported by a worldwide network of parts distribution facilities, dealer service centers, and technical training facilities to keep your equipment up and running. Cat customers rely on prompt, dependable parts availability and expertise through our global dealer network, ready to meet your needs 24/7.

Service Support. Every piece of Cat equipment is designed and built to provide maximum productivity and operating economy throughout its working life. Cat dealers offer a wide range of service plans that will

maximize uptime and return on your investment, including:

- Preventive Maintenance Programs
- Diagnostic Programs, such as Scheduled Oil Sampling and Technical Analysis
- Rebuild and Reman Options
- Customer Support Agreements

Application Awareness. Operating and maintenance costs are influenced by many application and site-specific factors, such as: material density, loading position, payload, grades, speeds, haul road design, and maintenance. To optimize total cost of ownership and productivity, your Cat dealer can provide you with a fundamental understanding of the effects application characteristics and operating techniques have on maintenance and operating costs.

Operation. With today's complex products, equipment operators must have a thorough understanding of machine systems and operating techniques to maximize efficiency and profitability. Your Cat dealer can arrange training programs to help operator's improve productivity, decrease downtime, reduce operating costs, enhance safety, and improve return on the investment you make in Cat products.

Technology Products. Cat dealers offer a range of advanced technology products such as VIMS[®] monitoring system and MineStar[®] information management system. These products include radio data communications, machine monitoring and diagnostics, fleet management, and haul road maintenance software – all designed to improve fleet efficiency, increase productivity, and lower costs.

www.cat.com. For more complete information on Cat products, dealer services, and industry solutions, visit us on the web at www.cat.com.

Safety

Caterpillar mining machines and systems are designed with safety as the first priority.

Product Safety. Caterpillar has been and continues to be proactive in developing mining machines that meet or exceed safety standards. Safety is an integral part of all machine and systems designs.

SAE and ISO Standards. The 793D is designed to many national and international standards.

Integral ROPS Cab. Resiliently mounted to the main frame to reduce vibration and sound, the integral ROPS structure is designed as an extension of the truck frame. The ROPS/FOPS structure provides “five sided protection” for the operator.

Ladder/Secondary Egress. A wide, stationary stairway allows easy access to and from the machine. The ladder on the left side of the machine permits secondary access or emergency egress.

Brake Systems. Four corner oil-cooled braking system provides excellent control in slippery conditions. The service brakes and retarding system are actuated by modulated hydraulic pressure, while secondary and parking brake functions are spring applied and hydraulic released. This system assures braking in the event of complete hydraulic failure.

Steering System. A twin double-acting cylinder steering system is designed to deliver precise control under all loading and underfoot conditions. The steering hydraulic system is separate from the main hydraulic system to prevent cross-contamination and overheating from other sources.

Engine Shutoff Switch. A secondary engine shutoff switch is located at ground level.

Electrical System Disconnect. A battery disconnect switch, located directly above the front bumper provides ground level lockout of the electrical system.



Overload Policy. Safety is integral to maintaining the highest productivity in mining machine operation. The Caterpillar 10/10/20 Overload Policy assures that steering and braking systems have sufficient capacity to perform, even at 20% overload.

Standard Safety Features.

- Slip resistant surfaces
- 75 mm (3 in) wide orange three-point operator restraint
- Wide-angle mirrors
- Body raised indicator
- Body retaining cable
- Guard rails
- Reverse neutralizer when dumping
- Low interior sound level

SAFETY.CAT.COM™.

Engine

Engine Model	Cat 3516B HD EUI	
Rated Power	1,750 rpm	
Gross Power – SAE J1995	1801 kW	2,415 hp
Net Power – SAE J1349	1743 kW	2,337 hp
Net Power – ISO 9249	1743 kW	2,337 hp
Net Power – 80/1269/EEC	1743 kW	2,337 hp
Torque Rise	23%	
Bore	170 mm	6.7 in
Stroke	215 mm	8.5 in
Displacement	78 L	4,760 in ³

- Power ratings apply at 1,750 rpm when tested under the specified condition for the specified standard.
- Ratings based on SAE J1995 standard air conditions of 25° C (77° F) and 99 kPa (29.61 Hg) dry barometer. Power based on fuel having API gravity of 35 at 16° C (60° F) and an LHV of 42 780 kJ/kg (18,390 Btu/lb) when engine used at 30° C (86° F).
- No engine derating required up to 2750 m (9,000 ft) altitude.
- Compliant with U.S. Environmental Protection Agency Tier I emissions standards.

Weights – Approximate

Gross Machine Operating Weight	383 749 kg	846,000 lb
Chassis Weight	116 707 kg	257,294 lb
Body Weight Range	21 795 – 54 431 kg / 48,050 – 120,000 lb	

- Chassis weight with 100% fuel, hoist, body mounting group, rims and tires.
- Body weight varies depending on how body is equipped.

Operating Specifications

Nominal Payload Capacity	218 tonnes	240 tons
Body Capacity (SAE 2:1)	129 m ³	169 yd ³
Maximum Capacity	Custom	
Top Speed – Loaded	54.3 km/h	33.7 mph
Steer Angle	36°	
Turning Diameter – Front	28.42 m	93 ft 3 in
Turning Circle Clearance Diameter	32.66 m	107 ft 2 in

- Body Capacity (SAE 2:1) with Dual Slope Body.
- Refer to the Caterpillar Mining Truck 10/10/20 Overload Policy for maximum gross machine weight limitations.

Transmission

Forward 1	11.8 km/h	7.3 mph
Forward 2	15.9 km/h	9.9 mph
Forward 3	21.5 km/h	13.4 mph
Forward 4	29 km/h	18.1 mph
Forward 5	39.4 km/h	24.5 mph
Forward 6	54.3 km/h	33.7 mph
Reverse	10.9 km/h	6.8 mph

- Maximum travel speeds with standard 40.00-R57 tires.

Final Drives

Differential Ratio	1:8:1
Planetary Ratio	16:1
Total Reduction Ratio	28.8:1

- Planetary, full-floating.

Suspension

Effective Cylinder Stroke – Front	130.5 mm	5.2 in
Effective Cylinder Stroke – Rear	105.5 mm	4.2 in
Rear Axle Oscillation	±4.9°	

Brakes

Outside Diameter	874.5 mm	34.5 in
Brake Surface – Front	89 817 cm ²	13,921 in ²
Brake Surface – Rear	134 500 cm ²	20,847 in ²
Standards	J-ISO 3450 JAN88, ISO 3450:1996	

- Gross Machine Operating Weight is 383 749 kg (846,000 lb).

Body Hoists

Pump Flow – High Idle	846 L/min	224 gal/min
Relief Valve Setting – Raise	20 370 kPa	2,955 psi
Body Raise Time – High Idle	20.25 Seconds	
Body Lower Time – Float	19.26 Seconds	
Body Power Down – High Idle	17.51 Seconds	

- Twin, two-stage hydraulic cylinders mounted inside main frame; double-acting cylinders in second stage.
- Power raise in both stages; power down in second stage.
- Automatic body-lower modulation reduces impact on frame.

Weight Distributions – Approximate

Front Axle – Empty	46%
Rear Axle – Empty	54%
Front Axle – Loaded	33%
Rear Axle – Loaded	67%

Capacity – Dual Slope – 100% fill factor

Struck	96 m ³	126 yd ³
Heaped (SAE 2:1)	129 m ³	169 yd ³

Service Refill Capacities

Fuel Tank	4354 L	1,150 gal
Fuel Tank (optional)	4922 L	1,300 gal
Cooling System	973 L	257 gal
Crankcase	265 L	70 gal
Rear Axle Housing	1022 L	270 gal
Steering Tank	227 L	60 gal
Steering System (Includes Tank)	341 L	90 gal
Brake/Hoist Hydraulic Tank	769 L	203 gal
Brake/Hoist System (Includes Tank)	1375 L	363 gal
Torque Converter/ Transmission Sump	102 L	27 gal
Torque Converter/Transmission System (Includes Sump)	189 L	50 gal

ROPS

ROPS Standards

- ROPS (Rollover Protective Structure) for cab offered by Caterpillar meets ISO 3471:1994 ROPS criteria.
- FOPS (Falling Objects Protective Structure) meets ISO 3449:1992 Level II FOPS criteria.

Sound

Sound Standards

- The operator sound pressure level measured according to work cycle procedures specified in ANSI/SAE J1166 MAY90 is 76 dB(A) for cab offered by Caterpillar, when properly installed and maintained and tested with doors and windows closed.
- The exterior sound pressure level for the standard machine measured at a distance of 15 m (49 ft) according to the test procedures specified in SAE J88 APR95, mid-gear moving operation is 89 dB(A).
- Hearing protection may be needed when operating with an open operator station and cab (when not properly maintained or doors/windows open) for extended periods or in a noisy environment.

Steering

Steering Standards	SAE J15111 OCT90, ISO 5010:1992
--------------------	------------------------------------

- Gross Machine Operating Weight is 383 749 kg (846,000 lb).

Tires

Standard Tire	40.00R57
---------------	----------

- Productive capabilities of the 793D truck are such that, under certain job conditions, TKPH (TMPH) capabilities of standard or optional tires could be exceeded and, therefore, limit production.
- Caterpillar recommends the customer evaluate all job conditions and consult the tire manufacturer for proper tire selection.

Dimensions

All dimensions are approximate. Shown with MSD II Body. Dimensions are with Dual Slope Body.

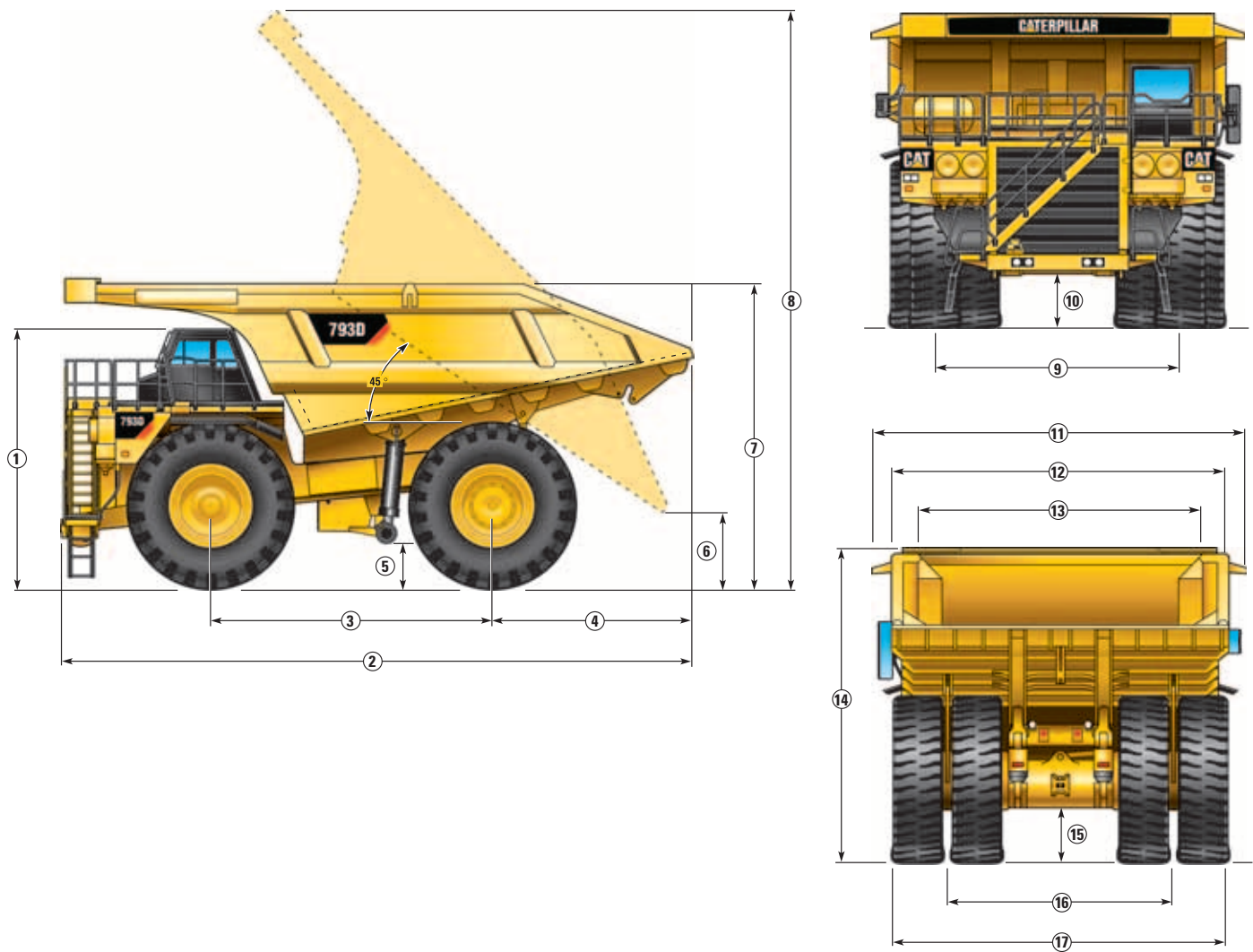

1	Height to Top of ROPS	5584 mm	18 ft 4 in
2	Overall Length	12 862 mm	42 ft 3 in
3	Wheelbase	5905 mm	19 ft 5 in
4	Rear Axle to Tail	3772 mm	12 ft 5 in
5	Ground Clearance	1005 mm	3 ft 4 in
6	Dump Clearance	1364 mm	4 ft 6 in
7	Loading Height – Empty	5871 mm	19 ft 4 in
8	Overall Height – Body Raised	13 113 mm	43 ft 1 in
9	Centerline Front Tire Width	5610 mm	18 ft 5 in
10	Engine Guard Clearance	1294 mm	4 ft 3 in
11	Overall Canopy Width	7680 mm	25 ft 3 in
12	Outside Body Width	6940 mm	22 ft 10 in
13	Inside Body Width	6500 mm	21 ft 4 in

14	Front Canopy Height	6494 mm	21 ft 4 in
15	Rear Axle Clearance	1128 mm	3 ft 8 in
16	Centerline Rear Dual Tire Width	4963 mm	16 ft 3 in
17	Overall Tire Width	7605 mm	24 ft 11 in

Retarding Performance – Standard

To determine retarding performance: Add lengths of all downhill segments and, using this total, refer to proper retarding chart. Read from gross weight down to the percent effective grade. Effective grade equals actual % grade minus 1% for each 10 kg/t (20 lb/ton) of rolling resistance. From this weight-effective grade point, read horizontally to the curve with the highest obtainable gear, then down to maximum descent speed brakes can properly handle without exceeding

cooling capacity. The following charts are based on these conditions: 32° C (90° F) ambient temperature, at sea level, with 40.00R57 tires.

NOTE: Select the proper gear to maintain engine rpm at the highest possible level, without overspeeding the engine. If cooling oil overheats, reduce ground speed to allow transmission to shift to the next lower speed range.

- Typical Field Empty Weight
- Gross Machine Operating Weight
383 749 kg/846,000 lb

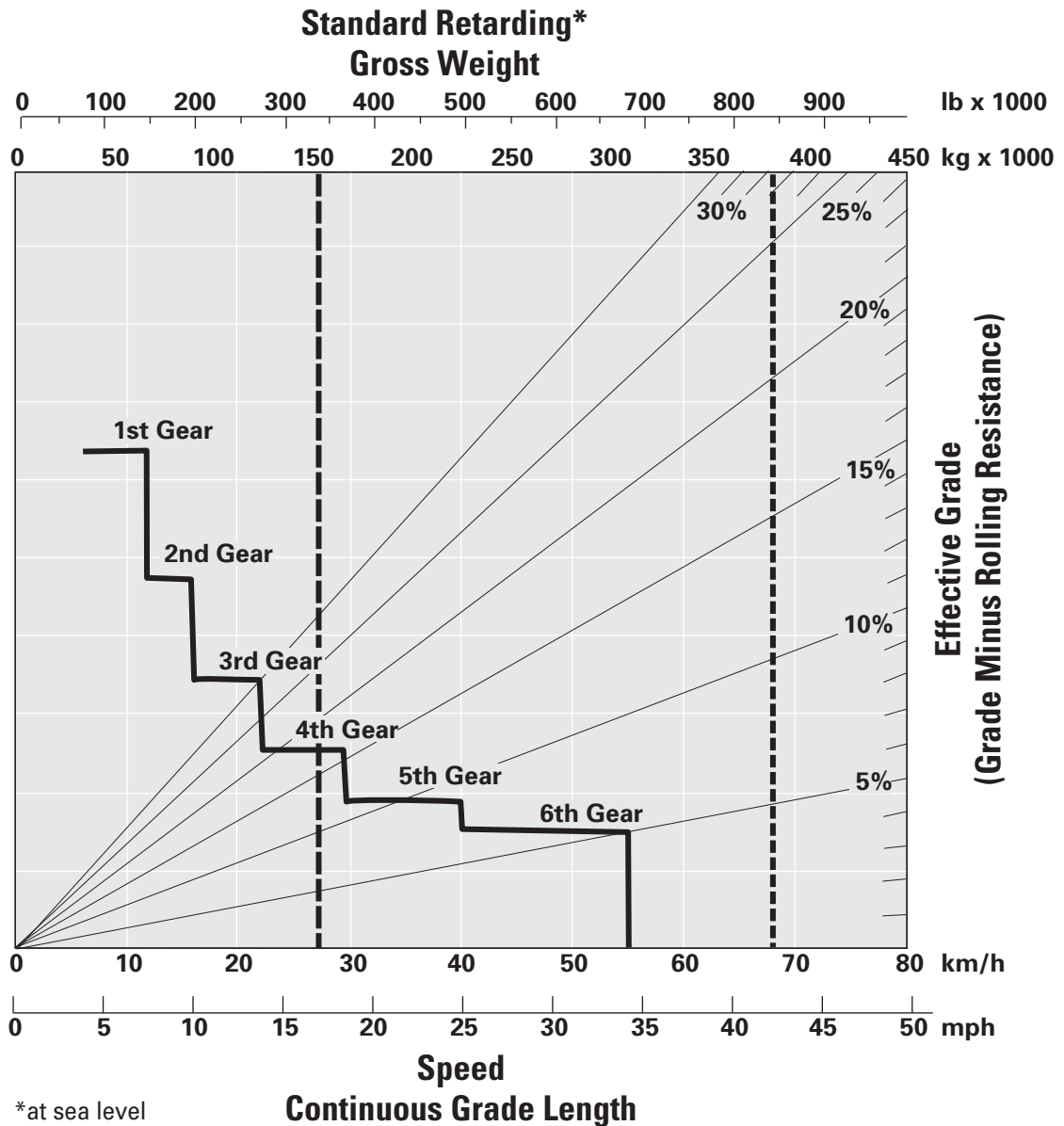

Retarding Performance – Standard

- - - - - Typical Field Empty Weight
 - - - - - Gross Machine Operating Weight
 383 749 kg/846,000 lb

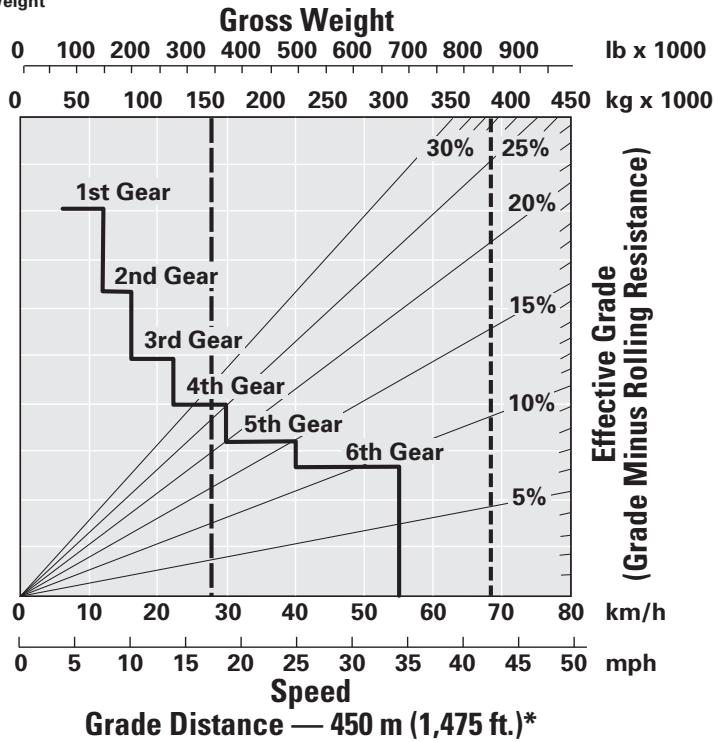

*at sea level

- - - - - Typical Field Empty Weight
 - - - - - Gross Machine Operating Weight
 383 749 kg/846,000 lb

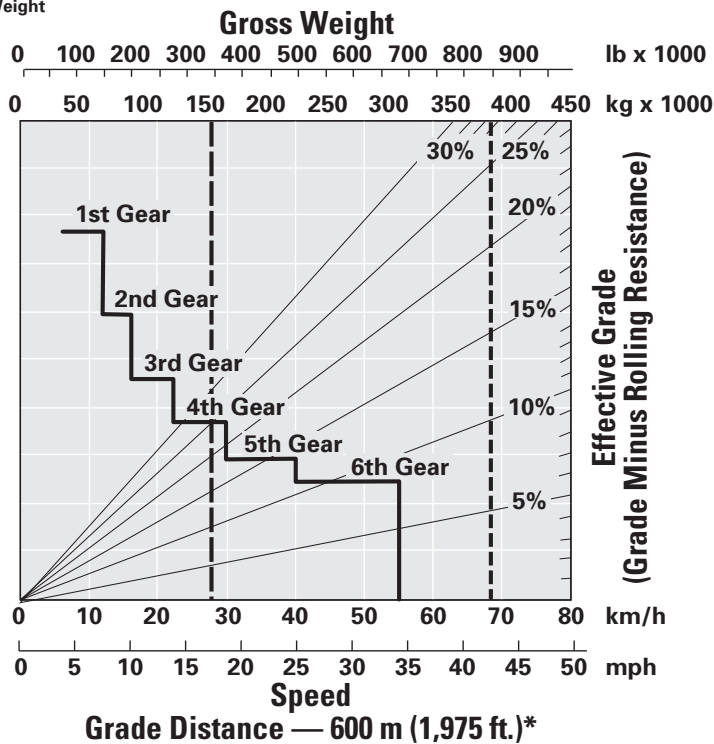

*at sea level

Retarding Performance – Standard

- Typical Field Empty Weight
- Gross Machine Operating Weight
383 749 kg/846,000 lb

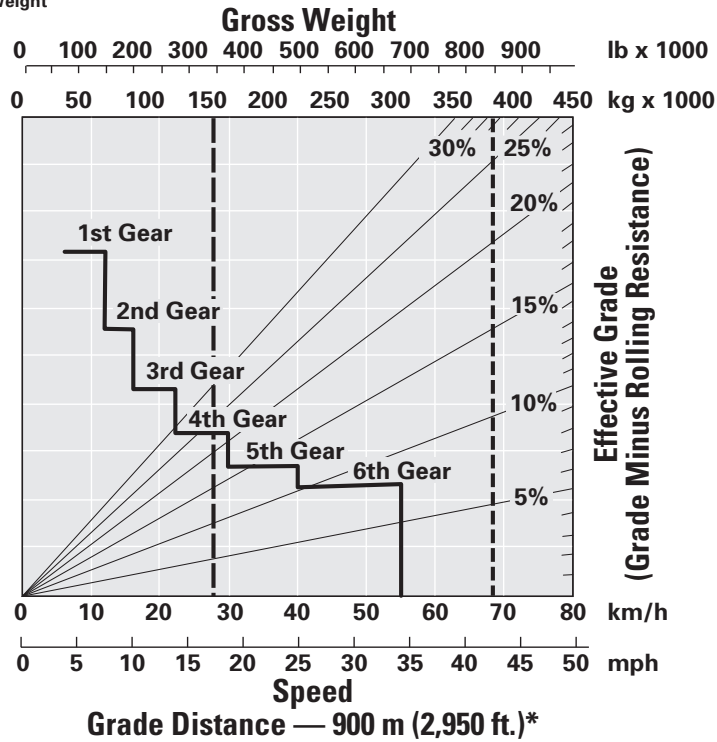

*at sea level

- Typical Field Empty Weight
- Gross Machine Operating Weight
383 749 kg/846,000 lb

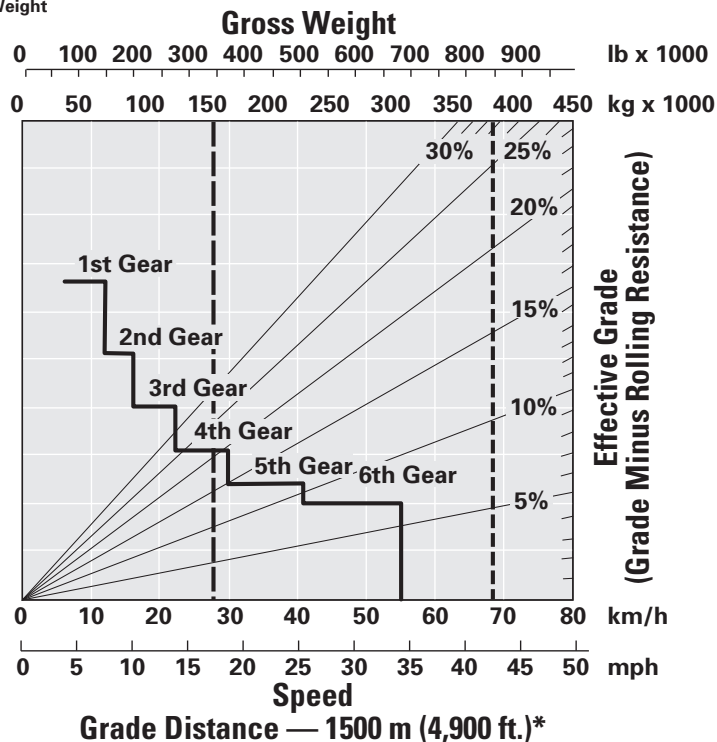

*at sea level

Retarding Performance – Extra Retarding

To determine retarding performance: Add lengths of all downhill segments and, using this total, refer to proper retarding chart. Read from gross weight down to the percent effective grade. Effective grade equals actual % grade minus 1% for each 10 kg/t (20 lb/ton) of rolling resistance. From this weight-effective grade point, read horizontally to the curve with the highest obtainable gear, then down to maximum descent speed brakes can properly handle without exceeding

cooling capacity. The following charts are based on these conditions: 32° C (90° F) ambient temperature, at sea level, with 40.00R57 tires.

NOTE: Select the proper gear to maintain engine rpm at the highest possible level, without overspeeding the engine. If cooling oil overheats, reduce ground speed to allow transmission to shift to the next lower speed range.

- Typical Field Empty Weight
- Gross Machine Operating Weight
383 749 kg/846,000 lb

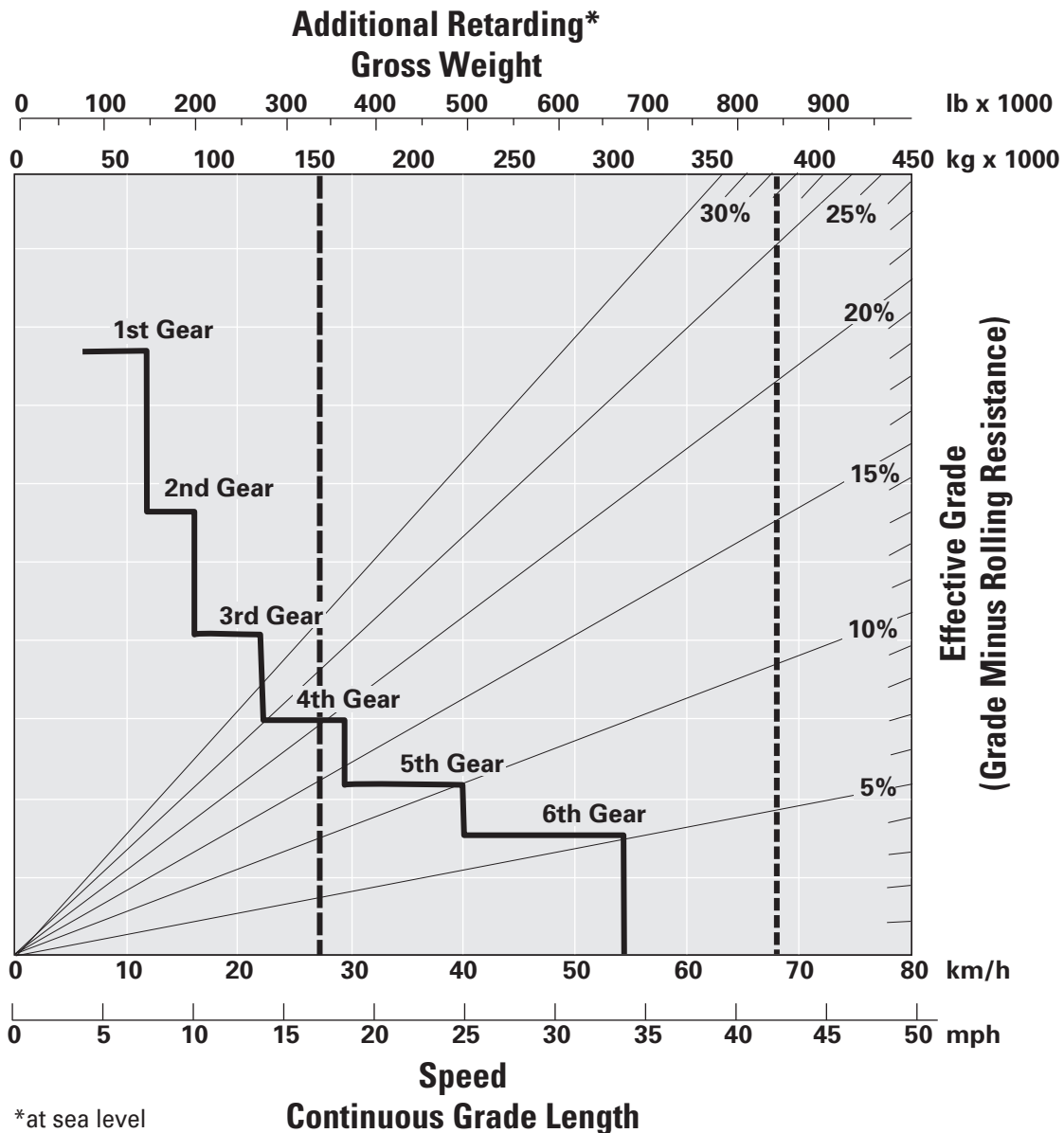

Retarding Performance – Extra Retarding

- Typical Field Empty Weight
- Gross Machine Operating Weight
383 749 kg/846,000 lb

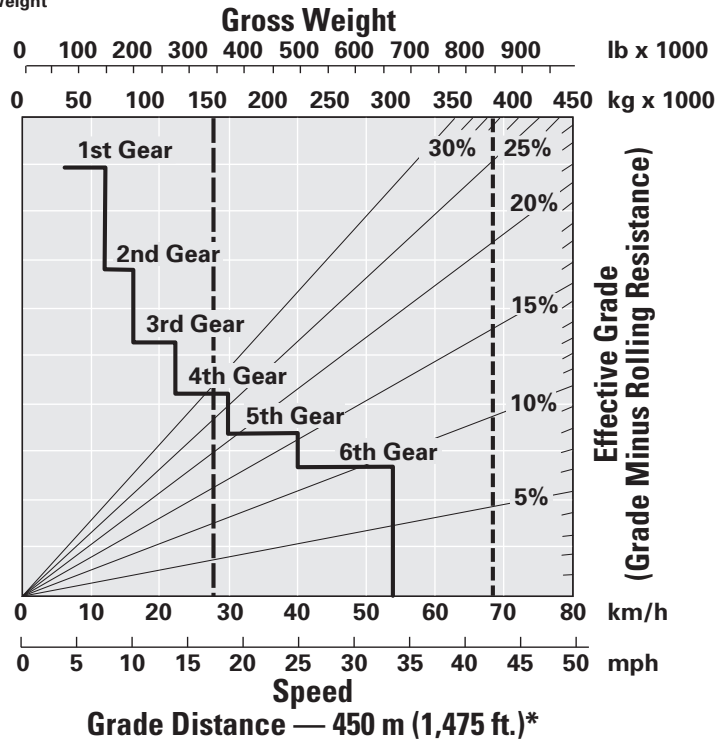

*at sea level

- Typical Field Empty Weight
- Gross Machine Operating Weight
383 749 kg/846,000 lb

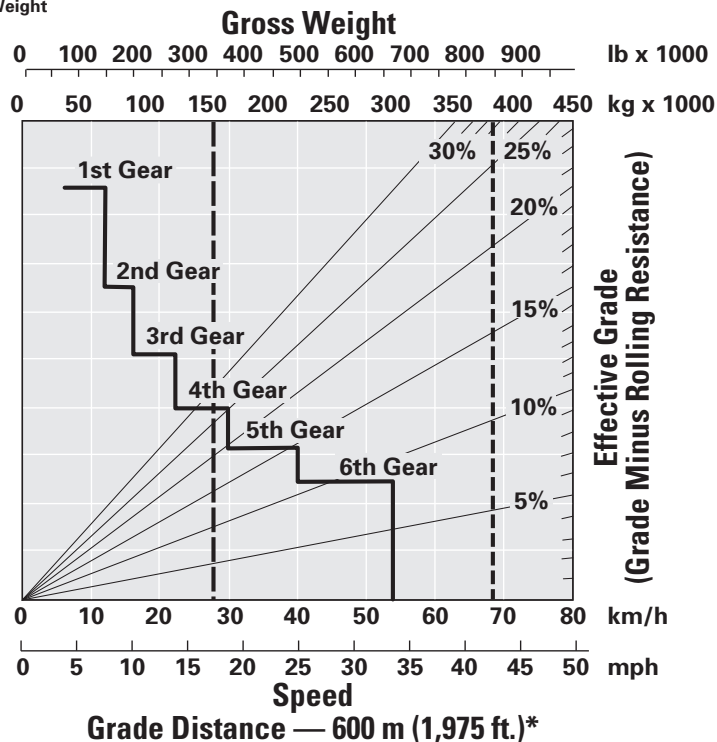

*at sea level

Retarding Performance – Extra Retarding

- - - - - Typical Field Empty Weight
 - - - - - Gross Machine Operating Weight
 383 749 kg/846,000 lb

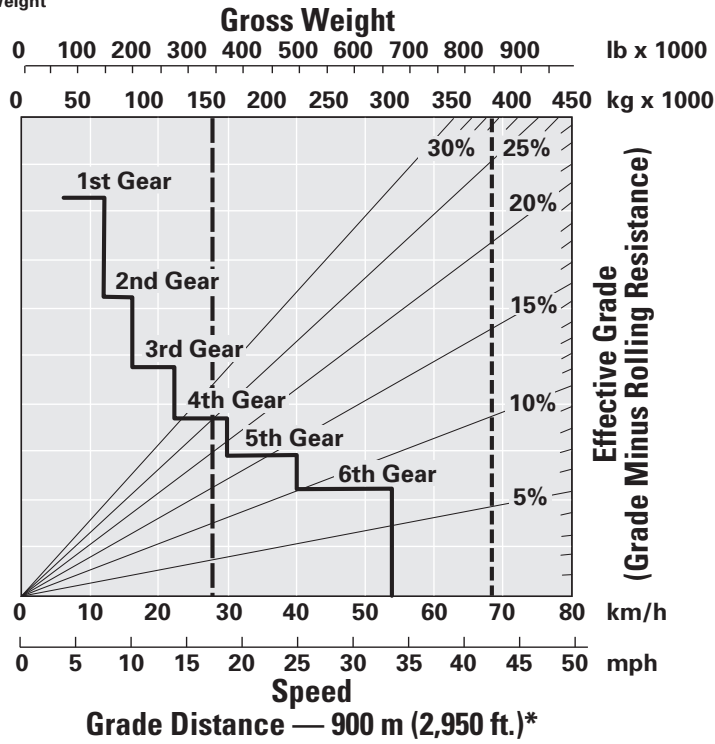

*at sea level

- - - - - Typical Field Empty Weight
 - - - - - Gross Machine Operating Weight
 383 749 kg/846,000 lb

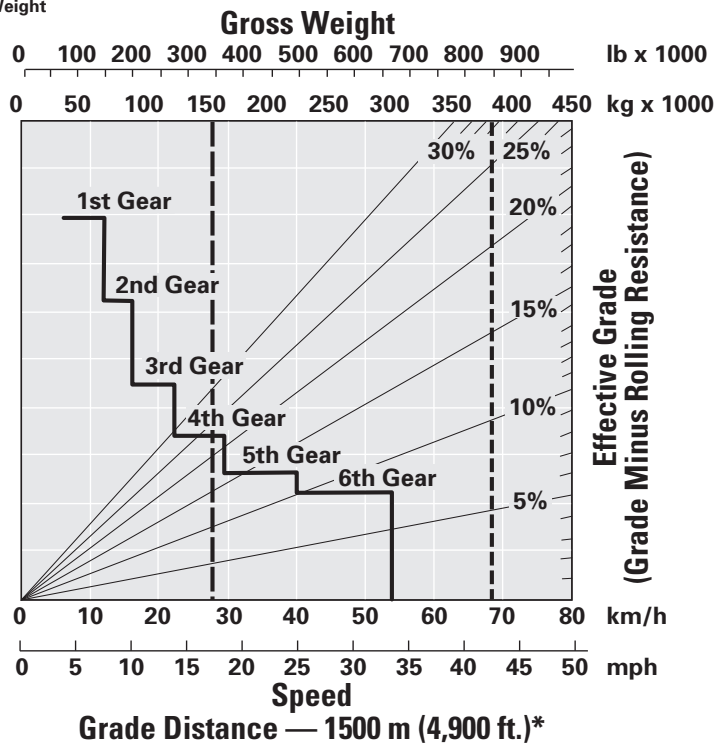

*at sea level

Gradeability/Speed/Rimpull

To determine gradeability performance: Read from gross weight down to the percent of total resistance. Total resistance equals actual percent grade plus 1% for each 10 kg/t (20 lb/ton) of rolling resistance. From this weight-resistance point, read

horizontally to the curve with the highest obtainable gear, then down to maximum speed. Usable rimpull will depend upon traction available and weight on drive wheels.

- Typical Field Empty Weight
- Gross Machine Operating Weight
383 749 kg/846,000 lb

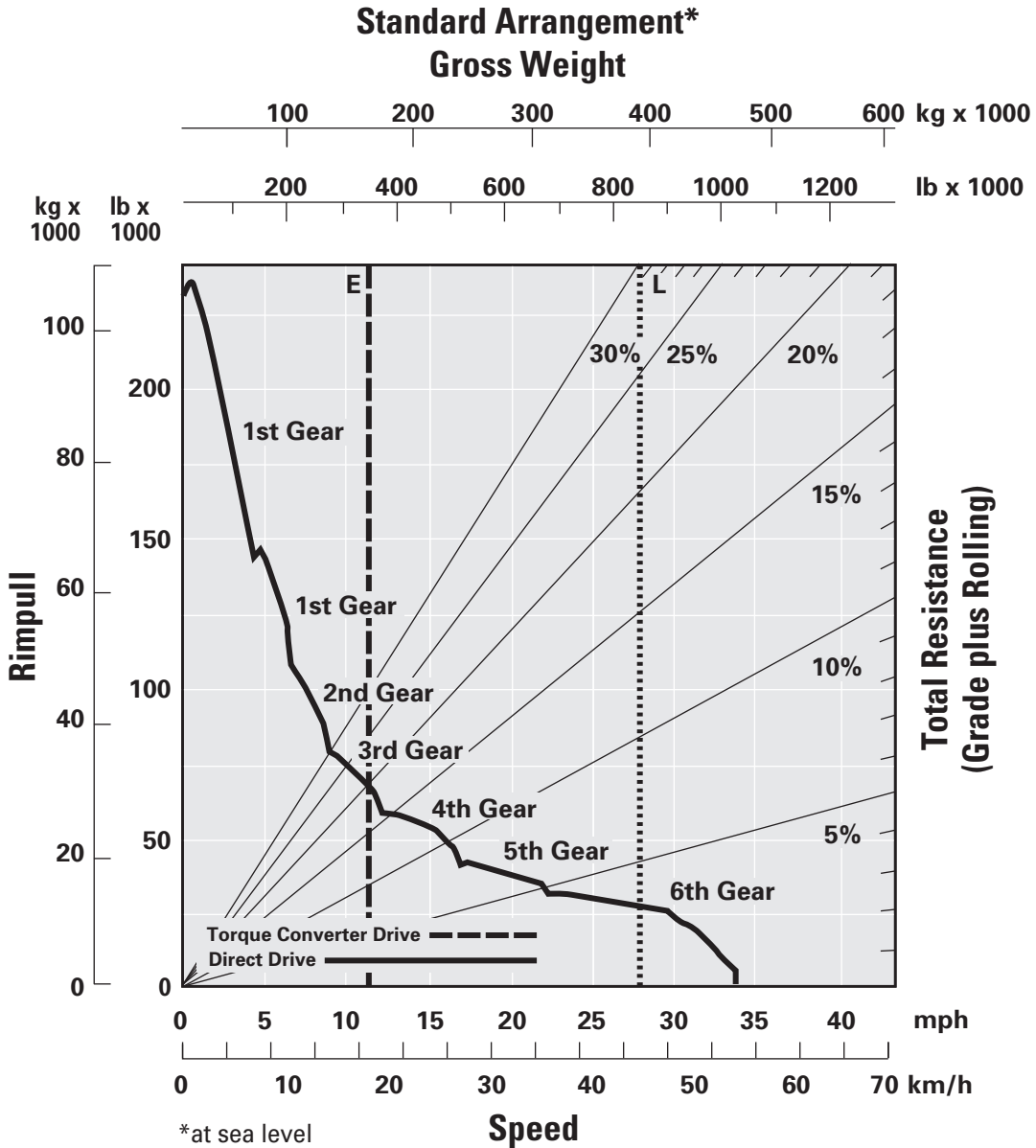

Standard Equipment

Standard equipment may vary. Consult your Caterpillar dealer for details.

Air Line Dryer (2)	Driveline Guard
Air Starter, Vane-type	Dumping, Auxiliary Quick Connect for “Buddy Dumping”
Alarm, Back-up	Electrical System, 12-volt to 24-volt
Alternator (105-amp)	Engine – Caterpillar 3516B HD EUI Diesel Engine
Automatic Lubrication System (Lincoln)	Air Cleaner with Precleaner (2)
Automatic Retarder Control	Elevated Low Idle Control
Batteries, 93-amp-hour, Low-maintenance, 12-volt (2)	Ether Starting Aid, Automatic
Body Mounting Group	Multi-Point Oil Pressure Sensing
Brake Release Motor for Towing	Turbocharger (4)/Aftercooler
Brake System	Fast-fill Fuel System, Wiggins
Oil-cooled, Multiple-disc, Front and Rear	Ground Level
Parking	Battery Disconnect
Secondary, Emergency	Engine Shutdown
Cab, ROPS	VIMS Dataports (2)
Air Cleaner Service Indicator	Lighting System
Air Conditioner	Back-up Lights, Halogen
Ashtray	Direction Signals and Hazard Warning (Rear Halogen)
Cigarette Lighter	Headlights, Halogen, With Dimmer
Coat Hook	LH Ladder Light and Service Deck Lights
Diagnostic Connector	Stop and Tail Lights (LED)
Electric Engine Control Fault Indicator	Under-hood Light
Electric Window (Operator Only)	Oil Change System, Quick Service
Entertainment Radio Ready	Reservoirs (Separate)
Glass, Tinted	Brake/Hoist
Heater/defroster: 11 070 kCal (43,930 Btu)	Steering/Fan
Horn	Transmission/Converter
Insulated and Sound Suppressed	Rims, Center Mounted for 40.00-R57 Tires
Dome Courtesy Light	Rock Ejectors
Mirrors, Right and Left	Steering, Auxiliary Quick Connect for Towing
Quad-Gauge Panel	Tie Down Eyes
Air Pressure	Tow Hooks, Front
Brake Oil Temperature	Tow Pin, Rear
Coolant Temperature	Traction Control System
Fuel Level	Transmission
Seat, Air Suspension w/3-piece compartment	6-speed, Automatic Power Shift
Seat, Passenger, Non-suspension	Body-up Shift Inhibitor
Seat Belts, 75 mm (3 in) wide retractable	Controlled Throttle Shifting
Speedometer	Directional Shift Management
Steering, Automatic Supplemental	Electronic Control and Downshift Inhibitor
Steering Wheel, Tilt, Padded, Telescopic	Lock-up Torque Converter
Storage Compartment	Neutral Coast Inhibitor
Sun Visor	Neutral Start Switch, Reverse Shift Inhibitor
Tachometer	Programmable Top Gear
Transmission Gear Indicator	Reverse Neutralizer during Dumping
VIMS Keypad	Vandalism Protection Locks
VIMS Message Center with Universal Gauge	VIMS® Monitoring System with Max Payload Speed Manager
Windshield Wiper and Washer	

Optional Equipment

With approximate changes in operating weights.

Optional equipment may vary. Consult your Caterpillar Dealer for specifics.

	kg	lb		kg	lb
Air suspension companion seat	12	27	Oil Renewal System (ORS)	8	17
Catwalk and handrail assemblies rear of cab	83	183	Prelubrication system	30	66
External payload display	54	119	Rear axle filtration cooler	75	165
Fuel tank (4921 L/1,300 gal)	139	306	Retractable visor	1	2
Heated mirrors	5	10	Road Analysis Control (RAC)	6	13
Heater, engine coolant and oil 240-volt external power	15	33	Starting systems:		
Heater, fuel recirculation type, non-electric	17	37	Air (IR turbine)	-15	-33
HID lights	14	31	Air (TDI turbine)	-31	-68
Hub odometer (km or miles)	6	13	Transmission lockout – ground level switch	5	11
			Wheel chocks	26	57
			Wiggins service center	137	302

Weight/Payload Calculation*

	kg	lb
Chassis**	64 061	141,230
Body Mounting Group	735	1,620
Tires (6) 40.00R57	21 364	47,100
Wheel Arrangement – Standard with 29" Rims	30 547	67,344
TOTAL EMPTY CHASSIS WEIGHT (CLEAN)	116 707	257,294
4% Debris	4668	10,292
Body Weight*	32 129	70,832
Full Liner	11 025	24,306
Tail Extension	1005	2,215
Side Boards	1332	2,936
Gross Machine Weight (empty)	166 866	367,875

* With Dual Slope Body.

** Includes standard arrangement, 100% fuel, starting system, seats, fan arrangement, exhaust system, tires, and all mandatory attachments less wheel group.

793D Mining Truck

For more complete information on Cat products, dealer services,
and industry solutions, visit us on the web at www.cat.com

© 2010 Caterpillar
All Rights Reserved
Printed in U.S.A.

Materials and specifications are subject to change without notice.
Featured machines in photos may include additional equipment.
See your Caterpillar dealer for available options.

AEHQ5600-02 (03-10)
Replaces AEHQ5600-01

CAT, CATERPILLAR, SAFETY.CAT.COM, their respective logos, S-O-S, VIMS, and Minestar,
“Caterpillar Yellow” and the “Power Edge” trade dress, as well as corporate and product
identity used herein, are trademarks of Caterpillar and may not be used without permission.

CATERPILLAR®