

# 160K

Motor Grader

CATERPILLAR®



## Engine

Engine Model	Cat® C7 ACERT™	
Base Power (1st gear) – Net	139 kW	186 hp
VHP Range – Net	139-154 kW (186-206 hp)	

## Moldboard

Blade Width	4.3 m	14 ft
-------------	-------	-------

## Weights

Gross Vehicle Wt, Typically Equipped			
total	15 785 kg	34,800 lb	
front axle	4735 kg	10,440 lb	
rear axle	11 049 kg	24,360 lb	

## 160K Features

### Cat C7 Engine

*Optimum power and fuel efficiency, combined with Power Management and Electronic Throttle Control, assure maximum productivity.*

### Power Train

*The Power Shift transmission features direct drive and electronic control for smooth, powerful shifts at any speed.*

### Balanced Hydraulics

*Proportional hydraulic flow provides outstanding "feel" and predictable movements.*

### Machine Safety

*Caterpillar has been and continues to be proactive in developing machines that meet or exceed safety standards.*

### Serviceability

*Grouping service points makes daily maintenance easier and faster, while enhanced diagnostics and monitoring, reduce downtime.*



## Contents

Power Train.....	3
Cat C7 Engine.....	3
Hydraulics .....	4
Structures, DCM.....	5
Work Tools and Attachments.....	6
Operator's Station.....	7
Electronic Solutions.....	8
Safety .....	9
Complete Customer Support.....	10
Serviceability.....	11
160K Motor Grader Specifications.....	12
160K Standard Equipment.....	16
160K Optional Equipment.....	17
Notes.....	18

**The 160K optimizes your investment by delivering maximum productivity and durability. The Cat C7 engine, direct-drive power shift transmission and load-sensing hydraulics work together to ensure the power and precision to get the job done.**

# Power Train

Smooth, responsive performance and reliability.

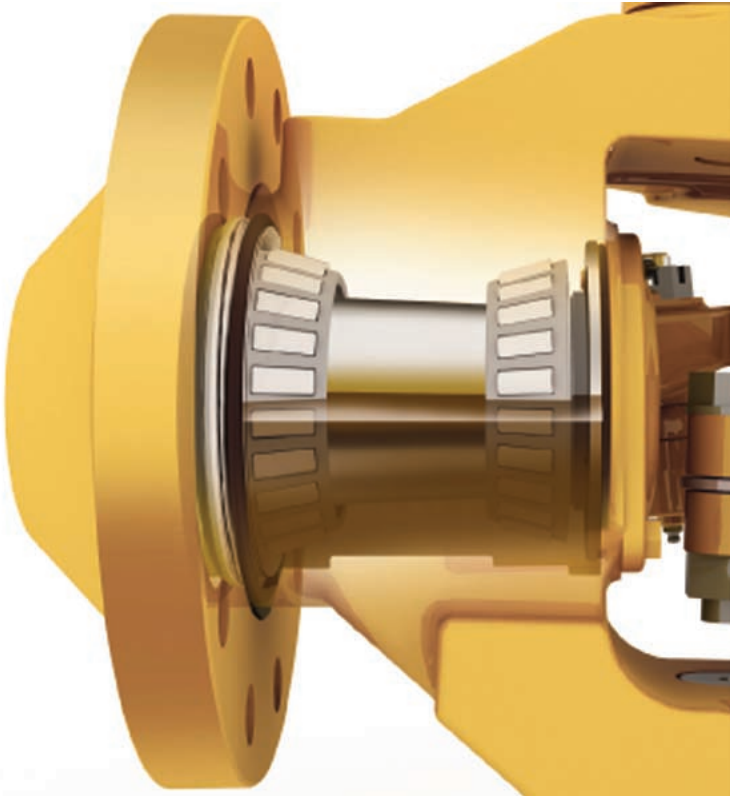

## Power Shift Transmission

Provides on-the-go, full-power shifting and inching capability. Direct drive delivers superior fuel efficiency and better “feel” of blade loads, material hardness and ground speed.

## Optional Autoshift – Automatic Gear Shifts

This feature automatically shifts the transmission at optimal points (in gears 3-8) so the operator can focus on the work, improving safety, productivity and ease of operation.

## Oil Disk Brakes – Completely Sealed, Adjustment Free

Oil-bathed, air actuated and spring-released, located at each tandem wheel to eliminate braking loads on the power train and to reduce servicing time. The large brake surface area provides dependable braking capability and extended life before rebuild.

## Front Axle with Cat Live Spindle Design

Caterpillar® sealed spindle keeps the bearings free from contaminants and lubricated in a lightweight oil to reduce owning and operating costs. Two tapered roller bearings support the wheel spindle. The larger tapered roller bearing is outboard where the load is greater, extending bearing life.

# Cat C7 Engine

Maximum power and efficiency.

## Power Management

The Cat C7 engine uses ACERT® Technology to provide electronic control, precision fuel delivery and refined air management, resulting in outstanding performance and lower emissions.

Variable Horse Power (VHP) is standard: base power in gears 1 and 2, 7.5 kW (10 hp) increase in gear 3, and an additional 7.5 kW (10 hp) increase in gears 4 through 8. Customized torque curves increase peak torque for improved lugging performance and responsiveness. The Electronic Throttle Control (ETC) provides easier, more precise and consistent throttle operation.

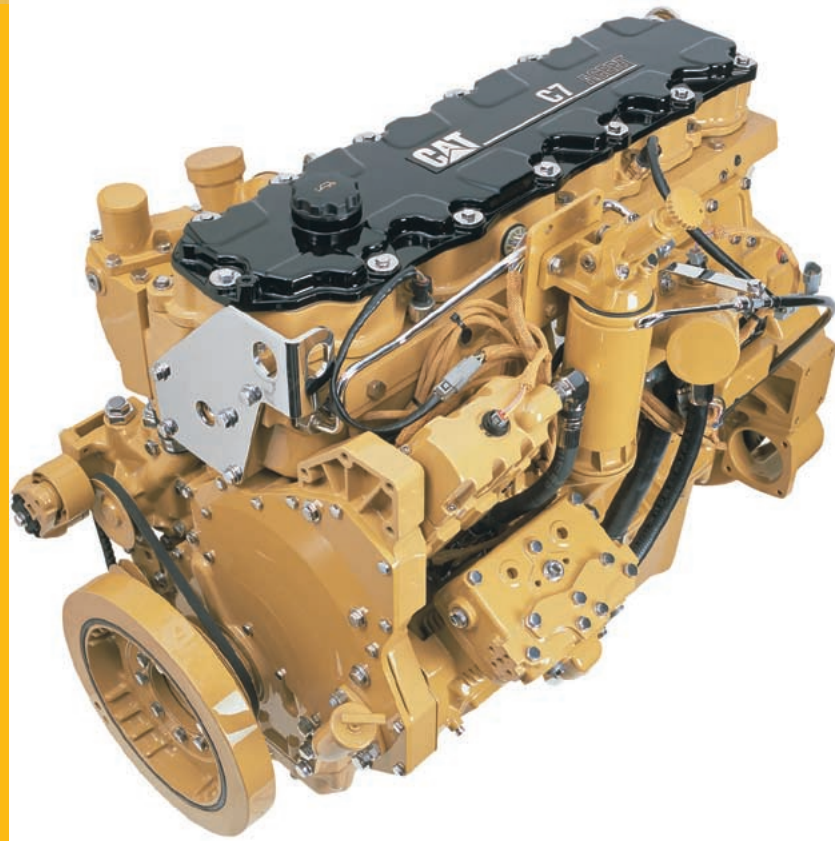

# Hydraulics

Balanced hydraulics deliver consistent, precise and responsive control.



## Balanced Flow, Independent Oil Supply

Hydraulic flow is proportioned to ensure all implements operate simultaneously. Independent oil supply prevents cross-contamination and provides proper oil cooling, which means less heat build-up and extended component life.

## Implement Control Valves

Provide outstanding operator “feel” and predictable system response for unmatched implement control. To help maintain exact blade settings, lock valves are built into all control valves. Line relief valves are also incorporated into selected control valves to protect the cylinders from over-pressurization.

## Load-Sensing Hydraulics (PPPC)

A load sensing variable displacement pump and the advanced Proportional Priority Pressure-Compensating (PPPC, or “triple-P C”) hydraulic valves provide superior implement control and better machine performance. PPPC valves have different flow rates for the head and rod ends of the cylinder. Continuously matching hydraulic flow and pressure to power demands creates less heat and reduces power consumption.

## Consistent and Predictable Movement

The hydraulic system uses valves that provide PPPC control for precise implement and machine operation. These valves contain spools that are specifically cut for each hydraulic function on the motor grader. They compensate for differences in flow requirements, based on cylinder size and the difference in surface volume between the rod end (blue) and barrel end (red) of the cylinder. The result is predictable, consistent hydraulic speeds whether extending or retracting the cylinder.





# Structures, DCM

Every component is designed for high strength and optimum durability.

## **Frame Structure – Provides Consistency and Strength**

Front frame is a continuous top and bottom plate construction. Flanged box section design removes welds from high stress areas, improving reliability. The rear frame structure has two box section channels with fully welded differential case for a solid working platform. An integrated bumper ties the rear frame together into a cohesive unit, to handle high stress loads.

## **Drawbar, Circle and Moldboard (DCM)**

The Y-frame drawbar is constructed of two solid beams for strength, durability, and precise blading control. This design allows the addition of a mid-mount scarifier without compromising blade positioning in extreme reach positions.

One-piece forged circle stands up to high stress loads. Raised wear surfaces prevent circle teeth wear against the drawbar. The 64 uniformly spaced circle teeth are flame cut and heat induction hardened to resist wear, and the circle is secured to the drawbar by six support shoes for maximum support.

The moldboard provides optimal curvature and large throat clearance that helps move all soil types quickly and efficiently. These features deliver excellent load distribution and minimal material buildup in the circle area while allowing large blade loads to roll freely.

## **Blade Lift Accumulators**

This optional feature uses accumulators to help absorb impact loads to the moldboard by allowing vertical blade travel. Blade lift accumulators reduce unnecessary wear and help to avoid unintended machine movement for increased operator safety.

# Work Tools and Attachments

Allow expansion of machine versatility, utilization, and performance.



## Moldboard Options

Standard moldboard length is 4.3 m (14 ft). Left and right side moldboard extensions (available through the Cat parts system) will increase moldboard surface area and extend reach capability.

## Ground Engaging Tools (GET)

A wide variety of Cat GET is available from Cat parts system, including cutting edges and end bits, all designed for maximum service life and productivity.



## Rear Ripper/Scarifier

The 160K optional ripper/scarifier is made to penetrate tough material fast and rip thoroughly for easier material movement with the moldboard. The ripper includes three shanks with the ability to add two more if needed. Nine scarifier shanks can also be added for additional versatility.

## Front Mounted Groups

A front mounted push plate/counterweight or front blade can be ordered.

## Mid-Mount Scarifier

Positioned between the front axle and the circle to break up tough material that the blade can then move, all in a single pass. The V-type scarifier can accommodate up to 11 teeth.



## Snow Removal Work Tools

Includes snow wings, angle blades, and V-plows. Multiple mounting options are available, increasing machine versatility. (Availability may differ by region.)



# Operator's Station

Caterpillar sets the standard for comfort, convenience and visibility.

## **Designed to keep operators comfortable, relaxed and productive throughout the long work shift.**

The 160K features:

- Electronic Clutch Pressure Control (ECPC) optimizes inching modulation and smoothes shifting
- Low efforts on all pedals, hydraulic controls and the transmission shifter
- Rocker switches and transmission shifter are backlit for night time operation
- The operator can adjust implement controls and steering wheel angle independently
- Clear view to the moldboard heel and tandem tires
- Fresh air filters above each cab door for quick replacement

### **In-dash Instrument Cluster**

The instrument panel, with easy-to read, high-visibility gauges and warning lamps, keeps the operator aware of critical system information. The dash cluster panel provides enhanced machine information and diagnostic capability. It includes an engine coolant temperature gauge, an articulation gauge, voltage gauge, and fuel level gauge. Service brake air pressure gauges are also standard. Speedometer and tachometer are optional. All major systems are monitored by warning lights.

### **Additional Cab Features**

Additional cab features include storage area, an adjustable control console, and a coat hook. The following optional features are also available: power port, air conditioner/heater, suspension seat, defroster fan, sun shade, backup lights, Product Link, and AccuGrade system ready.

NOTE: Some attachments are not available in all regions

# Electronic Solutions

Optimizes machine performance and availability.



## AccuGrade Grade Control System

The Cat AccuGrade™ System automatically controls the blade, improving operator efficiency and productivity. AccuGrade technology reduces the need for traditional survey stakes or grade checkers, so you can reach grade faster and in fewer passes than ever before.

The Cat AccuGrade System includes Cross Slope, Sonic, Laser, GPS or ATS electronic kits that are available in the AccuGrade price list.

The factory installed AccuGrade Attachment Ready Option provides additional mounting brackets, cab controls and electrical harnesses for easy installation of the AccuGrade Systems.

## Product Link

Streamlines diagnostic efforts, and reduces downtime, maintenance scheduling and costs by providing a communication flow of vital machine data and location. Product Link gives automatic updates on machine parameters such as machine hours, machine condition, location, fault codes and alarms directly to your office computer.

## Cat ET (Electronic Technician)

Cat ET is a two-way communication tool that gives service technicians easy access to stored diagnostic data, reducing machine downtime and lowering operating costs.

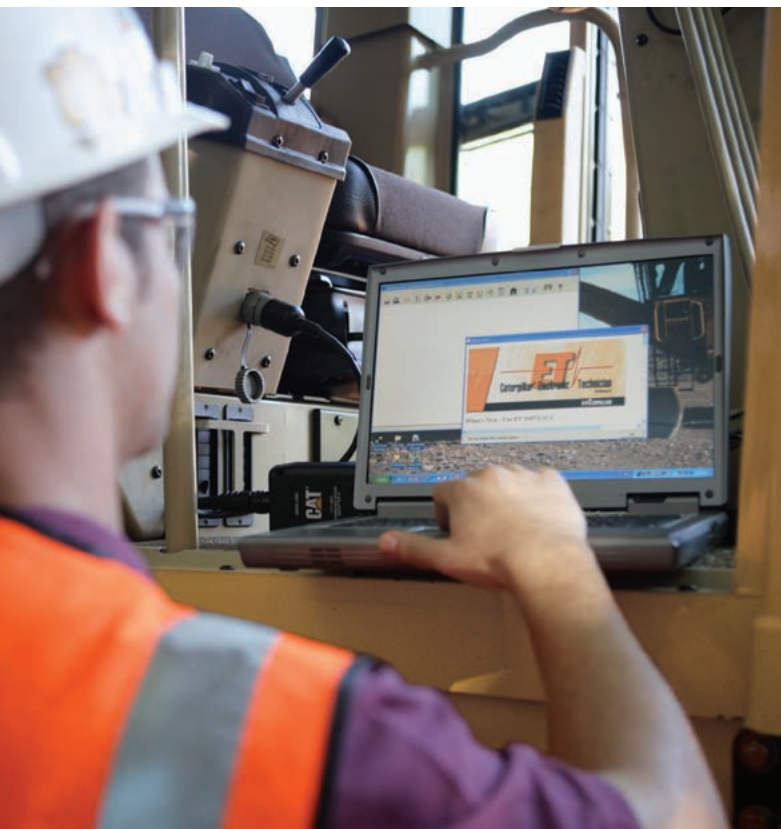





# Safety

Caterpillar machines continue to meet or exceed safety standards.

## **ROPS/FOPS Cab offers Low Sound and Vibration Levels**

The operator sound pressure level for the cab offered by Caterpillar, when properly installed, maintained and tested with the doors closed, meets or exceeds requirements set forth in ISO 6394:1998. The quiet environment improves operator working conditions. Steel non-skid steps use raised perforations to provide sturdy access to the tandems.

## **Brake Systems and Machine Protection**

Brakes located at each tandem wheel offer the largest total brake surface area in the industry, delivering dependable stopping power and longer brake life. Standard circle drive slip clutch protects the drawbar, circle and moldboard from shock loads when the blade encounters an immovable object. Blade lift accumulators help absorb impact loads to the moldboard by allowing vertical blade travel.

## **Electrical Disconnect Switch and Engine Shutoff Switch**

Disconnect switch provides ground-level lockout of the electrical system to prevent inadvertent machine starts. Engine shutoff allows anyone nearby to shut the machine down in case of an emergency.

## **Additional Safety Features**

Laminated glass on the front windows and lockable doors to reduce theft and vandalism are available with the optional cab. Brake lights, conveniently located grab rails, back up lights and alarm help ensure a safe work environment.

# Complete Customer Support

Cat dealers offer services to help you operate longer with lower costs.



## Your Cat dealer is ready to assist you with your purchase decision and everything after.

- Your Cat dealer can help you make detailed comparisons of the machines you're considering. How long do components last? What is the cost of preventive maintenance? What is the true cost of lost production?
- Look past initial price. Consider the financing options available as well as day-to-day operating costs. Many dealers offer services that can be included in the cost of the machine to yield lower equipment owning and operating costs over the long run.
- Smart equipment buyers plan for effective maintenance before buying equipment. Ask your Cat dealer about maintenance services before you make your purchase. Repair option programs guarantee the cost of repairs up front. Diagnostic programs such as Scheduled Oil Sampling and Technical Analysis help avoid unscheduled repairs.
- You will find nearly all parts at our dealer parts counter. In the rare case when we don't have a part in stock, our dealer network will find it and get it to you fast.
- Improving operating techniques can boost customer profits. Ask your Cat dealer about training videos, literature and other ideas to help you increase productivity. Caterpillar offers certified operator training classes to help you maximize the return on your machine investment.
- Your Cat dealer can evaluate the cost to repair, rebuild and replace your machine, so you can make the right choice.
- For more information on Cat products, dealer services and industry solutions, visit us at [www.cat.com](http://www.cat.com).

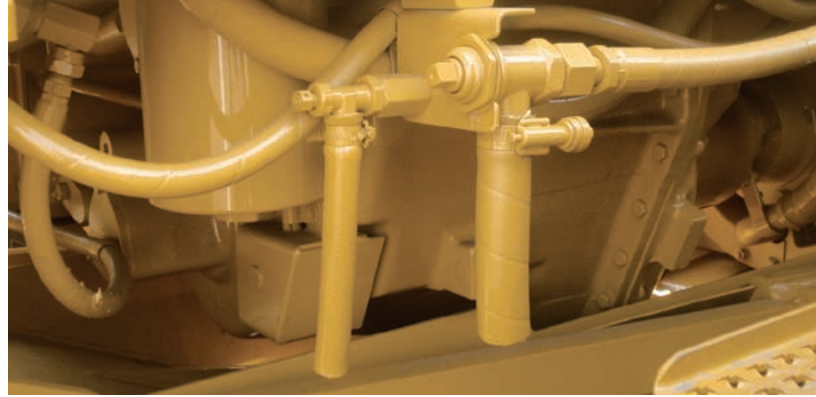

# Serviceability

Convenient service points make routine maintenance quick and easy.

## Grouped Service Points on the left side to help ensure proper maintenance

Easy access to service areas speeds up maintenance and ensures that routine service is performed on time. Ecology drains shorten service times and help prevent spills. Radiator cleanout access gives the operator the ability to clear away debris and other materials that build up around the radiator. Fuel water separator is easily accessible from the ground.

## Extended Service Intervals Reduce Downtime, Operating Cost

• 500 hour engine oil changes • 4,000 hour hydraulic oil changes • 12,000 hour engine coolant changes

## Diagnostics and Machine Monitoring via Electronic Technician

The dash cluster panel provides enhanced machine information and diagnostic capability, which allows faster servicing of the transmission and engine. Cat ET is a two-way communication tool that gives service technicians easy access to stored diagnostic data and lets them configure the machine parameters through the Cat Data Link.

## O-Ring Face Seals

O-Ring face seals create a reliable connection and are used in all hydraulic circuits to minimize the possibility of oil leaks.

## Separate Wiring Harnesses

This modular harness design provides simple disconnects for major machine repairs or rebuilds.

# 160K Motor Grader Specifications

## Engine

Engine Model	Cat® C7 ACERT™	
Base Power (1st gear) – Net	139 kW	186 hp
VHP Range – Net	139-154 kW (186-206 hp)	
VHP – gears		
1-2 Net	139 kW	186 hp
3 Net	147 kW	196 hp
4-8 Net	154 kW	206 hp
1-2 Gross	151 kW	203 hp
3 Gross	159 kW	213 hp
4-8 Gross	166 kW	223 hp
Displacement	7.2 L	439 in <sup>3</sup>
Bore	105 mm	4.1 in
Stroke	127 mm	5 in
Torque Rise	46%	
Max Torque	1076 N·m	794 lb ft
Speed @ rated power	2,000 rpm	
Number of cylinders	6	
Derating altitude	3048 m	10,000 ft
Hi Ambient Fan speed – max	1,800 rpm	
Hi Ambient Capability	50° C	122° F

- Net power is tested per ISO 9249, SAE J1349, and EEC 80/1269 standards in effect at the time of manufacture.
- Net power advertised is the power available at rated speed of 2,000 rpm, measured at the flywheel when engine is equipped with fan, air cleaner, muffler and alternator.
- Maximum torque measured at 1,000 rpm in gears 4-8.

## Power Train

Forward/Reverse Gears	8 fwd/6 rev	
Transmission	Direct drive, Power shift	
Brakes		
Service	Air actuated, multiple oil-disc	
Service, surface area	23 948 cm <sup>2</sup> 3,712 in <sup>2</sup>	
Parking	Air actuated, multiple oil-disc	
Secondary	Dual circuit	

- Brakes meet the following standards: SAE J/ISO3450 JAN 98.

## Operating Specifications

Top Speed		
fwd	46.4 km/h	28.8 mph
rev	36.6 km/h	22.8 mph
Turning Radius, outside front tires	7.5 m	24 ft 9 in
Steering Range – left/right	47.5 Degrees	
Articulation Angle – left/right	20 Degrees	
Fwd.		
1st	4.1 km/h	2.5 mph
2nd	5.5 km/h	3.4 mph
3rd	8.0 km/h	4.9 mph
4th	11.0 km/h	6.8 mph
5th	17.0 km/h	10.6 mph
6th	23.2 km/h	14.4 mph
7th	31.9 km/h	19.8 mph
8th	46.4 km/h	28.8 mph
Rev.		
1st	3.2 km/h	2 mph
2nd	5.9 km/h	3.7 mph
3rd	8.7 km/h	5.4 mph
4th	13.4 km/h	8.4 mph
5th	25.2 km/h	15.6 mph
6th	36.6 km/h	22.8 mph

- Maximum travel speeds calculated at rated rpm on standard machine configuration with 14.00-24 12PR (G-2) tires.

## Hydraulic System

Circuit Type	Load Sensing, Closed Center, Proportional Priority Pressure Compensating System	
Pump Type	Variable Piston	
Pump Output	210.5 L/min	55.6 gal/min
Maximum System Pressure	25 500 kPa	3,698.5 psi
Standby Pressure	3600 kPa	522.1 psi
Reservoir Tank Capacity	55 L	14.5 gal

- Pump output measured @ 2,150 rpm.

## Moldboard

Blade Width	4.3 m	14 ft
Moldboard		
height	686 mm	27 in
thickness	25 mm	1 in
Arc Radius	413 mm	16.3 in
Throat Clearance	90 mm	3.5 in
Cutting Edge		
width	203 mm	8 in
thickness	16 mm	0.6 in
End Bit		
width	152 mm	6 in
thickness	16 mm	0.6 in
Blade Pull		
typical GVW	9945 kg	21,924 lb
max GVW	12 908 kg	28,458 lb
Down Pressure		
typical GVW	8260 kg	18,211 lb
max GVW	13 472 kg	29,700 lb

- Blade Pull calculated at 0.9 traction coefficient, which is equal to ideal no-slip conditions, and Gross Vehicle Weight (GVW).

## Blade Range

Circle Centershift		
right	728 mm	28.7 in
left	752 mm	29.6 in
Moldboard Sideshift		
right	943 mm	37.1 in
left	851 mm	33.5 in
Maximum Blade Position Angle	90 Degrees	
Blade Tip Range		
forward	40 Degrees	
backward	5 Degrees	
Max shoulder reach outside of tires		
right	2261 mm	89 in
left	2223 mm	87.5 in
Max lift above ground	452 mm	17.8 in
Max depth of cut	790 mm	31.1 in

## Ripper

Ripping depth – max	462 mm	18.2 in
Ripper shank holders, quantity	5	
Ripper shank holder spacing	533 mm	21 in
Penetration force	8518 kg	18,779 lb
Pryout force	9281 kg	20,461 lb
Machine length increase, beam raised	970 mm	38.2 in

## Scarifier

Mid, V-Type		
Working width	1184 mm	46.6 in
Scarifying depth, max	229 mm	9 in
Scarifier shank holders quantity	11	
Scarifier shank holder spacing	116 mm	4.6 in
Rear		
Working width	2300 mm	90.6 in
Scarifying depth, max	266 mm	10.5 in
Scarifier shank holders quantity	9	
Scarifier shank holder spacing	267 mm	10.5 in

- The mid-mount scarifier is positioned under the drawbar between the moldboard and front axle.

## Frame

Circle		
diameter	1553 mm	61.1 in
blade beam thickness	40 mm	1.6 in
Drawbar		
height	127 mm	5 in
width	76.2 mm	3 in
Front axle		
height to center	628 mm	24.7 in
wheel lean, left/right	18 Degrees	
total oscillation	32 Degrees	
Front-top/bottom plate		
width	305 mm	12 in
thickness	25 mm	1 in
Front-side plates		
width	242 mm	9.5 in
thickness	12 mm	0.5 in
Front-linear weights		
min	165 kg/m	112 lb/ft
max	213 kg/m	144 lb/ft
Front-section modulus		
min	2083 cm <sup>2</sup>	127 in <sup>2</sup>
max	4785 cm <sup>2</sup>	291 in <sup>2</sup>
<b>Tandems</b>		
Height	572 mm	22.5 in
Width	201 mm	7.9 in
Sidewall thickness		
inner	16 mm	0.6 in
outer	18 mm	0.7 in
Drive chain pitch	51 mm	2 in
Wheel axle spacing	1522 mm	59.9 in
Tandem oscillation		
front up	15 Degrees	
front down	25 Degrees	

# 160K Motor Grader Specifications

## Service Refill

Fuel Capacity	344 L	91 gal
Cooling system	40 L	10.6 gal
Engine Oil	25 L	6.6 gal
Trans./Diff./Final Drives	47 L	12.4 gal
Tandem housing (each)	80 L	21.1 gal
Front wheel spindle bearing housing	0.5 L	0.1 gal
Circle drive housing	7 L	1.8 gal

## Weights

Gross Vehicle Wt, Base		
total	15 155 kg	33,411 lb
front axle	4546 kg	10,023 lb
rear axle	10 609 kg	23,388 lb
Gross Vehicle Wt, Typically Equipped		
total	15 785 kg	34,800 lb
front axle	4735 kg	10,440 lb
rear axle	11 049 kg	24,360 lb
Gross Vehicle Wt, Max		
total	22 066 kg	48,647 lb
front axle	7723 kg	17,026 lb
rear axle	14 343 kg	31,621 lb

- Base weight calculated on standard machine configuration with 14.00-24 12PR (G-2) tires, full fuel tank, coolant, lubricants and operator.
- Typical operating weight calculated on standard machine configuration with Cab High Profile ROPS, 14.00-24 12PR (G-2) tires, full fuel tank, coolant, lubricants and operator.
- Max Vehicle Weight includes all compatible attachments with Cab High Profile ROPS, 14.00-24 12PR (G-2) tires, full fuel tank, coolant, lubricants and operator.

## Standards

ROPS/FOPS	ISO 3471:1994/ ISO 3449:1992
Steering	ISO 5010:1992
Brakes	ISO 3450:1996

- These standards are met when the machine is equipped with a cab.

## Dimensions

All dimensions are approximate, based on standard machine configuration with 14.00-24 12PR (G-2) tires. Dimensions vary depending on the tires and attachments selected.

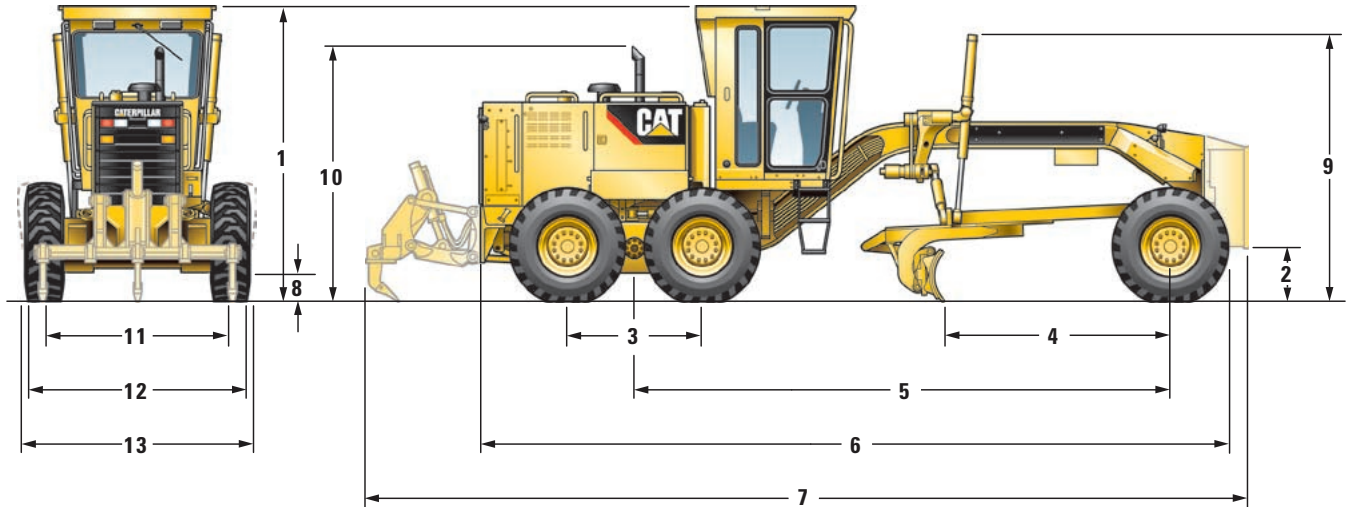

<b>1</b> Height – ROPS Cab	3322 mm	130.8 in
Height – Non-ROPS Cab	3316 mm	131 in
Height – ROPS Canopy	3322 mm	130.8 in
<b>2</b> Ground Clearance – Center Front Axle	626 mm	24.6 in
<b>3</b> Length – Between Tandem Axles	1523 mm	60 in
<b>4</b> Length – Front Axle to Moldboard	2555 mm	100.6 in
<b>5</b> Length – Front Axle to Mid Tandem	6086 mm	239.6 in
<b>6</b> Length – Front Tire to Rear of Machine	8504 mm	334.8 in

<b>7</b> Length – Counterweight to Ripper	10 013 mm	394.2 in
<b>8</b> Ground Clearance, Trans. Case	362 mm	14.3 in
<b>9</b> Height – Top of Cylinders	3049 mm	120 in
<b>10</b> Height to Exhaust Stack	2895 mm	114 in
<b>11</b> Width – Tire Center Lines	2065 mm	81.3 in
<b>12</b> Width – Outside Rear Tires	2452 mm	96.6 in
<b>13</b> Width – Outside Front Tires	2481 mm	97.7 in

# 160K Standard Equipment

Standard equipment may vary. Consult your Caterpillar dealer for details.

## ELECTRICAL

Alternator, 95 amps, sealed  
Backup alarm, reversing lights  
Batteries, maintenance free 750 CCA  
Electrical system, 24 volt  
Horn, electric  
Lights, stop and tail  
Motor, starting  
Product Link Ready  
Working lights

## OPERATOR ENVIRONMENT

Accelerator  
Control console, adjustable  
Gauge cluster (includes voltmeter, articulation, engine coolant temperature, air brake pressure and fuel level)  
Guard rails, operator station  
Hydraulic controls, load sensing (right/left blade lift, circle drive, centershift, sideshift, blade tip, front wheel lean & articulation)  
Indicator lights (includes high beam, LH & RH turn, low engine oil pressure, throttle lock, check engine, transmission filter bypass and check, centershift pin, brake air pressure, parking brake engaged, AccuGrade, auto shift)  
Key start/stop switch  
Meter, hour  
Power steering, hydraulic  
Seat, vinyl-covered static  
Seat belt  
Steering wheel, tilt, adjustable  
Storage area, cooler/lunch box  
Throttle, electronic control

## POWER TRAIN

Air cleaner, dry type radial seal with service indicator and automatic dust ejector  
Air to air after cooler (ATAAC)  
Blower fan  
Brakes, oil disc, four-wheel air actuated  
Differential with lock/unlock  
Engine, Cat C7 with ACERT technology, diesel with automatic engine derate and idle control. Meets U.S. EPA Tier 2 and EU Stage II emission standards.  
Fuel water separator  
Muffler, under hood  
Parking brake, multi-disc, sealed and oil cooled  
Prescreener  
Priming pump, fuel, resiliently mounted  
Sediment drain, fuel tank  
Tandem drive  
Transmission, 8 speed forward and 6 speed reverse, power shift, direct drive with electronic shift control and overspeed protection  
VHP (Variable Horse Power)

## OTHER STANDARD EQUIPMENT

Bumper, rear  
CD ROM Parts Book  
Circle drive slip clutch  
Cutting edges, 152 mm × 16 mm (6" × 5/8") curved DH-2 steel  
Doors, Engine compartment  
Drawbar, 6 shoes with replaceable nylon composite wear strips  
Endbits, 16 mm (5/8") DH-2 steel  
Frame, articulated with safety lock  
Fuel tank, 344 L (91 gal)  
Ground level engine shutdown  
Link bar, 7 position  
Moldboard, 4267 mm × 686 mm × 25 mm (14' × 27" × 1") blade with hydraulic sideshift and tip  
S·O·S ports, engine, hydraulic, transmission and cooling  
Toolbox with padlock  
Vandalism protection – including cap locks for hydraulic tank, radiator access cover, fuel tank, engine and transmission oil check/fill and lockable battery boxes.

## TIRES, RIMS, & WHEELS

A partial allowance for tires on 229 mm (9") single piece rims is included in the base machine price and weight. A tire **MUST** be selected from the Mandatory Attachments section.

## ANTIFREEZE

Extended Life Coolant to -35° C (-30° F)



Optional equipment may vary. Consult your Caterpillar dealer for details.

	kg	lb
<b>GUARDS</b>		
Guard, transmission	98	216
<b>OPERATOR ENVIRONMENT</b>		
Air conditioner with heater	91	201
Heater, cab	14	31
<b>CAB/CANOPY</b>		
Cab, ROPS*	0	0
Cab, Non-ROPS*	-182	-401
Canopy, ROPS*	-118	-260
Seat, vinyl adjustable	14	31
Seat, cloth, contour	11	24
Fan, defroster, front window	2	4
Fan, defroster, rear window	2	4
Sun shade, rear	3	7
Wiper/washer, rear	7	15
Wipers, intermittent front	1	2
Mirrors, dual inside	1	2
Mirrors, outside mounted	8	18
Power port, 12V accessory	2	4
Radio ready entertainment	5	11
Tachometer/Speedometer	1	2

\* Cab weights represent changes to Typically Equipped machine weights.

	kg	lb
<b>RIPPER/SCARIFIER</b>		
Ripper/Scarifier, rear mounted	961	2,119
Scarifier, mid mounted, V-type	845	1,862
<b>LIGHTS</b>		
Bar mounted, low, directional and headlights	13	29
Cab and bar mounted, high, directional, headlights and work lights	22	49
<b>POWER TRAIN</b>		
Autoshift	2	4
<b>OTHER ATTACHMENTS</b>		
Product Link	5	10
Snow Wing Mounting, frame-ready	91	201
AccuGrade ARO	10	22
Dryer, air	13	29
Push plate, counterweight	907	2,000
Accumulator, blade lift	77	170
Battery, extreme duty (1400 CCA)	14	31
Ether, starting aid	1	2
Heater, engine coolant, 220V	1	2

	kg	lb
<b>HYDRAULICS</b>		
Pump, hydraulic, high capacity	2	4
Hydraulic arrangements with one or more additional hydraulic valves are available for rear ripper, mid-mount scarifier, dozer, snow plow and snow wing.		
<b>BLADES, MOLDBOARDS</b>		
Blade, front	1180	2,601
Cutting edge, 203 mm × 19 mm (8" × 3/4"). For use with 14' blade	21	46
Endbits, overlay, reversible pair for use with 203 mm (8") cutting edges	11	24





# 160K Motor Grader

For more complete information on Cat products, dealer services, and industry solutions, visit us on the web at [www.cat.com](http://www.cat.com)

© 2009 Caterpillar Inc.  
All rights reserved

AEHQ5937 (03-2009)

Materials and specifications are subject to change without notice. Featured machines in photos may include additional equipment. See your Caterpillar dealer for available options.

CAT, CATERPILLAR, SAFETY.CAT.COM, their respective logos, "Caterpillar Yellow" and the POWER EDGE trade dress, as well as corporate and product identity used herein, are trademarks of Caterpillar and may not be used without permission.

**CATERPILLAR®**