

D6T

Track-Type Tractor



Engine

| | | |
|----------------------|----------------|--------|
| Engine Model | Cat® C9 ACERT™ | |
| Engine Power | STD | |
| Maximum – ISO 14396 | 166 kW | 223 hp |
| Net Power – ISO 9249 | 138 kW | 185 hp |
| Engine Power | XL/LGP | |
| Maximum – ISO 14396 | 179 kW | 240 hp |
| Net Power – ISO 9249 | 149 kW | 200 hp |

Operating Weights

| | | |
|-----|------------------|------------------|
| STD | 19 429-19 969 kg | 42,834-44,024 lb |
| XL | 20 449-20 661 kg | 45,082-45,550 lb |
| LGP | 22 039 kg | 48,588 lb |

Features

Operator Station

Ease of operation, as well as cab comfort and layout, help keep operators comfortable and more productive. The D6T offers excellent visibility all around the machine, enhancing operator efficiency and job site safety.

Power Train

The D6T is powered by a Cat C9 engine with ACERT Technology that delivers proven performance and reliability.

Integrated Technologies

AccuGrade™ systems help improve productivity and efficiency, as well as help less experienced operators perform more effectively. Cat Product Link™ is an excellent tool to help fleet managers maximize efficiency and control costs.

Equipped for Versatility

A variety of undercarriage and work tool offerings help customers equip the D6T for optimized performance in a wide range of working conditions.

Serviceability and Customer Support

Cat machines are designed for ease of serviceability so they can spend more productive time on the job site. Cat dealer preventive maintenance and repair expertise, along with machine rebuild capability, help reduce overall owning and operating costs.

Contents

| | |
|--|----|
| Operator Station..... | 3 |
| Engine | 3 |
| Implement and Steering Controls | 4 |
| Power Train..... | 5 |
| Structures..... | 6 |
| Undercarriage | 6 |
| Cooling System..... | 7 |
| Sustainability | 7 |
| Integrated Technologies..... | 8 |
| Work Tools and Rear Implements | 9 |
| Serviceability and Customer Support..... | 10 |
| Specifications..... | 11 |
| Standard Equipment..... | 16 |
| Optional Equipment..... | 17 |



The Cat D6T dozer has earned a reputation for best-in-class versatility, productivity and resale value. Because it excels across a wide range of dozing tasks, customers choose the D6T for everything from dozing, ripping, scraper work and land clearing to finish grading, backfilling trenches, building oil/gas/wind farm pads and working landfills. The D6T offers many of the robust features found on larger tractors, with the reliability and low operating costs customers have come to expect from Cat Track-Type Tractors.

Operator Station

Comfort and Convenience



The D6T cab is designed for operator productivity, safety and comfort. An isolation-mounted, pressurized cab reduces noise and vibration. Large single-pane windows offer excellent visibility. The low rear window enables excellent rearward visibility and lets the operator see the ripper tip. The tapered hood, notched fuel tank, and narrow single-shank ripper carriage give the operator a clear line of sight to front and rear work areas.

The Cat Comfort Series seat is well padded and adjustable, with bolsters to help support the operator when working on slopes. Armrests are adjustable without tools, and heating/air conditioning vents evenly distribute airflow. The cab is pre-wired for a radio and equipped with two speakers, an antenna and a radio mount recessed in the headliner. A 10-amp, 12-volt power converter is also included to provide convenient supplemental power for cellular phones and computers.

Engine

Power and Sustainability

Every component of a Cat engine is carefully designed to maximize durability and reliability. Precise controls optimize power and fuel efficiency while reducing emissions.

The D6T features a Cat C9 engine with ACERT Technology. A series of Caterpillar engineered innovations provide advanced electronic control, precision fuel delivery and refined air management, resulting in outstanding performance and lower emissions.

Modular design and advanced electronic diagnostics enhance the engine's serviceability. An optional sand blast grid equips the machine for high airborne debris applications.

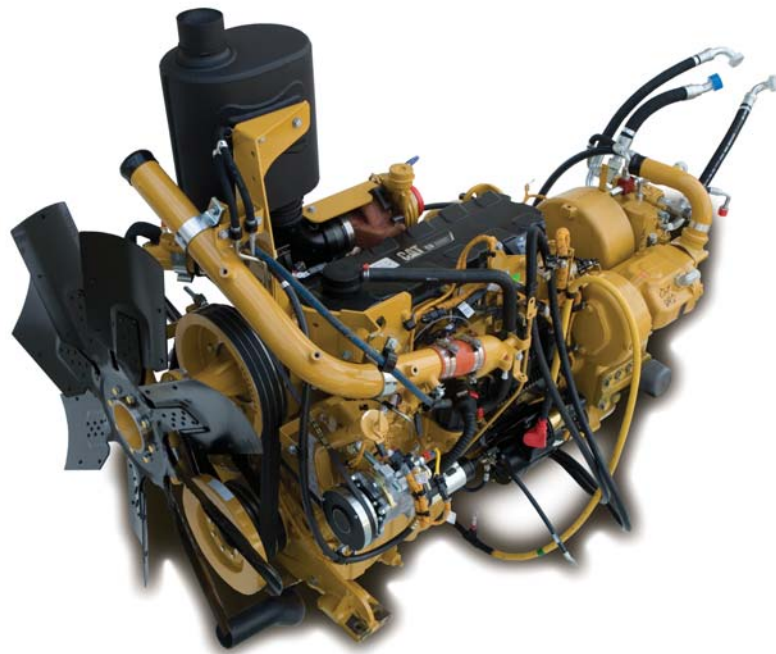

Implement and Steering Controls

Ergonomically designed for ease of operation



Steering and Transmission Control

Turns and directional changes are controlled with a single tiller handle. Buttons change the electronically controlled powershift transmission. Operators are able to work precisely in tight areas and around obstacles.

Dozer and Ripper Control Levers

The D6T features ergonomically designed dozer and ripper controls with low-effort, pilot-operated hydraulics. The dozer control is equipped as an electro-hydraulic control when the AccuGrade Ready Option is installed.

Throttle Rocker Switch

The fingertip rocker switch activates high or low idle. A decelerator pedal gives the operator full control of engine speed when the rocker switch is in the high idle position. Engine speed can be set between high and low idle by simultaneously using the decelerator pedal and holding the Rabbit side of the throttle switch for three seconds.

Work Tool Lock-Out Switch

Work tool lock-out prevents inadvertent operation of hydraulic work tool attachments.

Auto-Shift/Auto-Kickdown

Operators can pre-select a forward and reverse speed setting for easy, efficient directional changes. Auto-kickdown allows the transmission to automatically downshift when significant load increases are detected.

Instrument Panel and Cat Monitoring System

The instrument panel, with easy-to-read gauges and warning lamps, keeps the operator aware of all system information. All gauges and readouts are easily visible in direct sunlight. The Cat Monitoring System has a dash mounted instrument cluster showing on-the-go operating information and insight into operation and maintenance needs.



Power Train

Powerful efficiency

The powershift transmission and differential steering work in tandem with the Cat C9 engine to deliver outstanding power, productive performance and reliability.

Two Pump Hydraulic System

A dual hydraulic pump design provides dedicated hydraulic power to steering and implements for a 20 percent steering improvement. The split pump design improves response in simultaneous steering/implement applications for greater maneuverability. The constant flow in steering circuit improves hydraulic cooling, increasing cooling capacity.

Multi Velocity Program (MVP)

This exclusive machine control system allows the operator to choose from five speed ranges in Forward and Reverse to best match machine speed to applications and ground conditions. MVP improves productivity in light applications (partial blade loads), where more speed flexibility is desired.

Differential Steering System

Differential steering maintains full power to both tracks, providing best in class turning with a loaded blade. When one track speeds up, the other slows down an equal amount. Maneuverability – especially with large blade loads – is improved, as well as cycle times in some applications. Greater load capacity, power and speed control are possible in soft underfoot conditions on steep slopes because both tracks are powered during turns. Low effort tiller bar, touch shift control and steering modulation insure ease of operation.

Torque Divider

A single-stage torque divider sends 70 percent of engine torque through a converter and 30 percent through a direct drive shaft. This provides greater drive line efficiency and higher torque multiplication, delivering more power to the ground to optimize operator productivity.

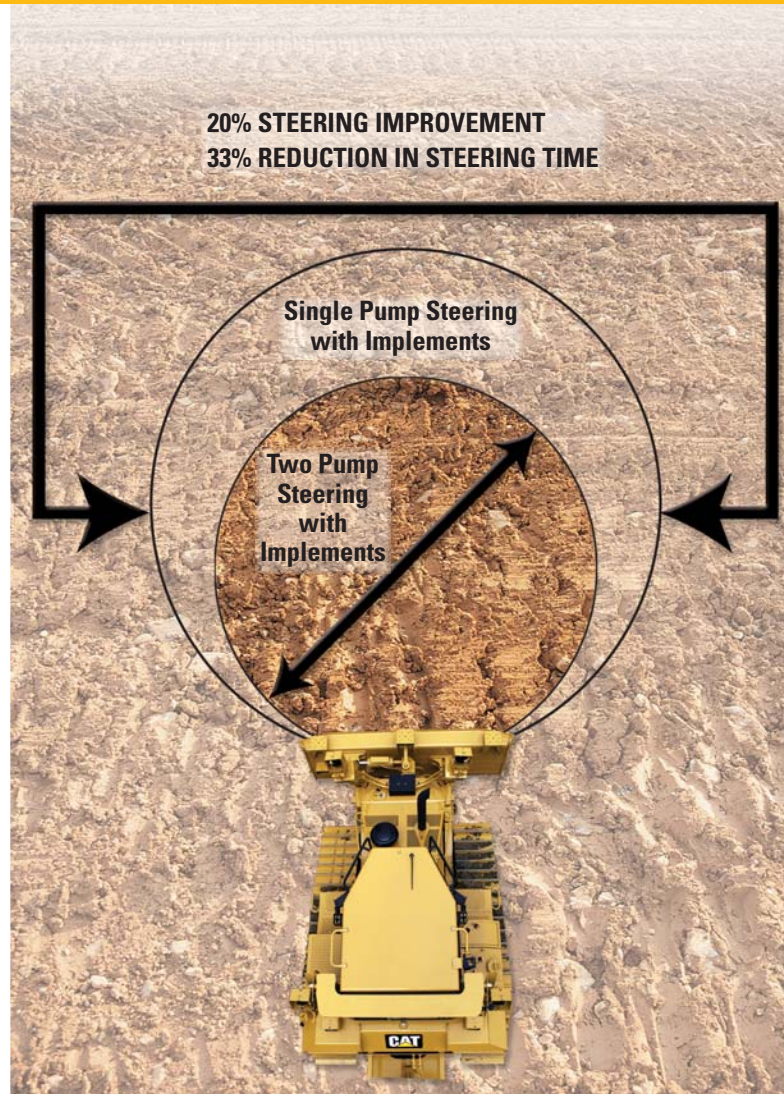

Structures

Rugged design for maximum service

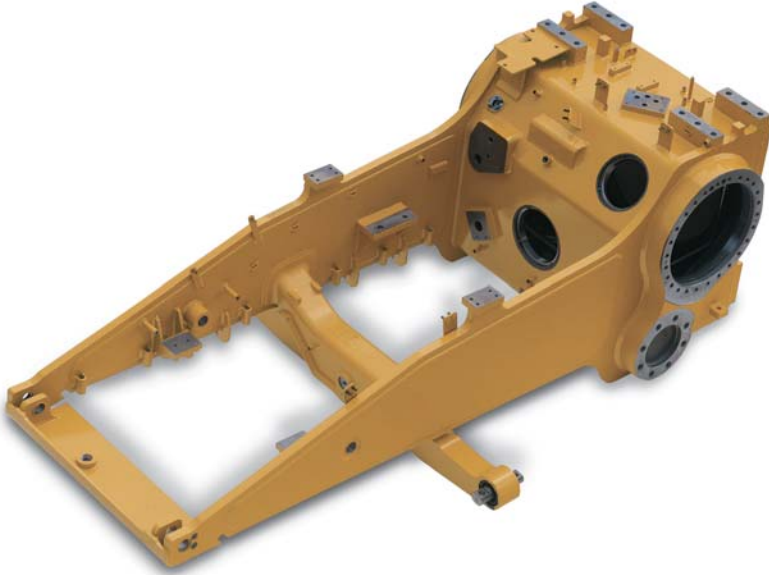

The foundation of every Cat dozer is a rugged frame built to absorb high impact shock loads and twisting forces. A reinforced saddle, welded front cross-member and steel castings on the main case add to the overall strength.

The pivot shaft is bolted to the mainframe and connects to the rear roller frames to allow independent oscillation. The pivot shaft distributes impact loads through the case. This design eliminates alignment problems and the need for diagonal braces on the roller frames.

The pinned equalizer bar gives the roller frames the ability to oscillate up and down to better match ground contours for maximum traction and operator comfort. Bolted end pins offer longer life and reduce downtime with improved serviceability and reliability. A remote lubrication point in the engine compartment provides easy access to lubricate the center pin of the equalizer bar as part of scheduled maintenance practices.

Undercarriage

Engineered for performance

The D6T features the Caterpillar elevated sprocket design that isolates final drives, axles, and steering components from harsh impacts. The modular design aids serviceability to help reduce maintenance costs. A variety of undercarriage configurations and track shoe designs help optimize performance and undercarriage life.

SystemOne™ Undercarriage

SystemOne can help reduce total undercarriage owning and operating costs in many applications. Lifetime sealed and lubricated cartridges eliminate bushing turns and sprockets require no replacement during the life of the chain. All SystemOne undercarriage components are designed to work and wear as a system for longer track life.

Heavy Duty Undercarriage

Heavy duty undercarriage is well-suited to aggressive applications like land clearing, side-slopes, or working in rocky or uneven terrain. Components are designed for extended wear life in abrasive conditions and high impact applications.

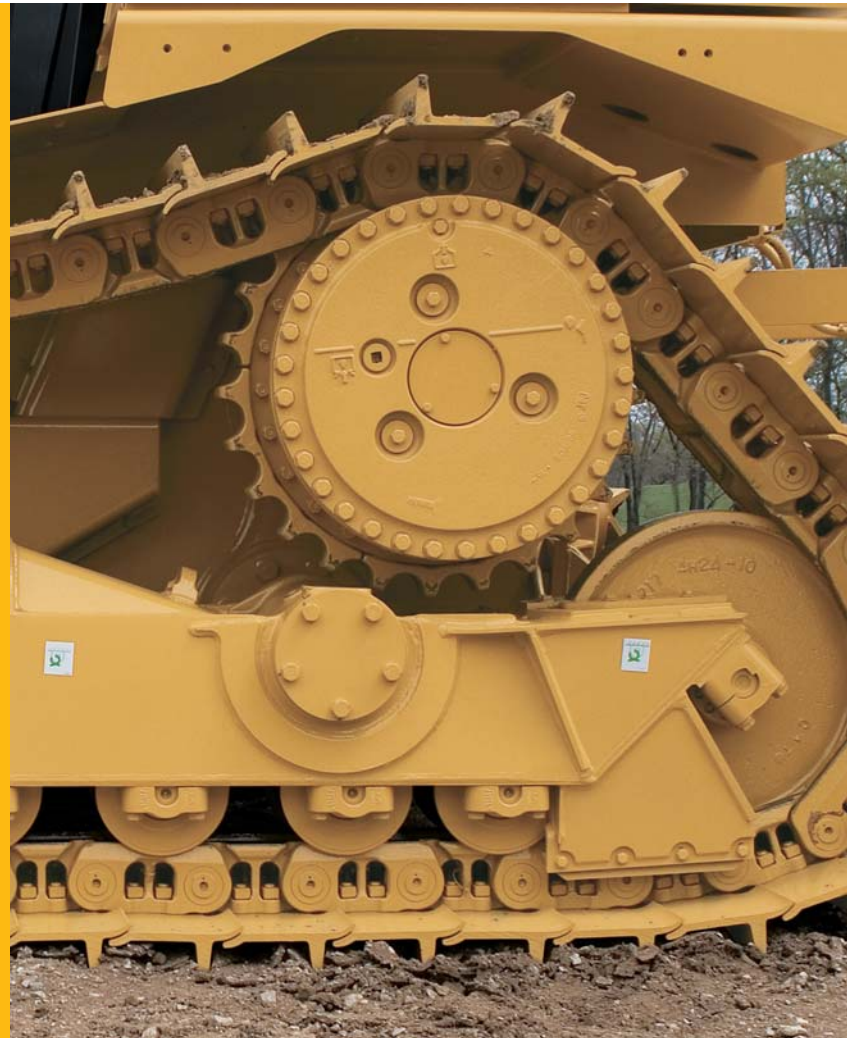

Cooling System

Durable and Efficient

The D6T cooling system is durable and efficient, utilizing aluminum bar plate construction on the radiator cores and Air To Air After Cooler (ATAAC). Aluminum bar plate provides durability and allows for high heat transfer and superior corrosion resistance. The radiator consists of twin unit cores that act together as one heat exchanger.

The Air To Air After Cooler is part of an advanced air management system that brings cool air to the engine. This increases life, reduces emissions, and helps maximize fuel efficiency.

The twin core is designed for easy service. Either half of the radiator can be removed by itself to reduce downtime and repair costs. A sight gauge makes daily service checks convenient.

The rugged aluminum bar plate construction helps protect against coolant leaks caused by tube punctures in abrasive applications. The unit core construction also reduces leak potential by eliminating core seals.



Sustainability

Thinking generations ahead

- ACERT engine technology helps improve fuel efficiency and reduce emissions.
- Ease of operation, operator comfort and excellent visibility help operators stay focused for enhanced job site safety.
- Technologies like Product Link help improve overall efficiency, safe fuel and fluids, and reduce equipment wear and tear.
- Ecology drains help make draining fluids more convenient and help prevent spills.
- Major components are built to be rebuilt, eliminating waste and saving customers money by giving the machine and/or major components a second – and even third – life.





Integrated Technologies

Solutions to make work easier and more efficient

Caterpillar is the only manufacturer to offer fully-integrated electronic technology solutions that enable greater accuracy, higher productivity, lower operating costs and more profitability.

AccuGrade

AccuGrade uses positioning and guidance technologies, machine sensors, and automatic blade control to help operators get to grade faster, easier and more efficiently. Digital design plans, real-time cut/fill data, and in-cab guidance give operators detailed information to work more confidently and achieve greater accuracy, in fewer passes, using less material. Operators can stay on grade and improve productivity and accuracy by nearly 50 percent over conventional methods. Grade stakes and checkers are minimized, making the work site safe, efficient, and cost effective. AccuGrade technologies include Cross Slope, Sonic, Laser, GPS, and/or Universal Total Station (UTS).

Product Link

Product Link helps take the guesswork out of equipment management with remote monitoring capabilities for your machine or your entire fleet. Track asset location, hours, fuel usage, diagnostic codes, idle time and more through the secure VisionLink® user interface, powered by Trimble. Knowing where your equipment is, what it's doing and how it's performing enables you or your Cat dealer to manage your fleet in real-time so you can maximize efficiency, improve productivity, and lower operating costs.

**Product Link licensing not available in all areas. Please consult your Cat dealer for availability.*

Work Tools and Rear Implements

Equipped for the job

L-Shaped Push Arms

L-shaped push arms bring the blade closer to the machine than diagonal brace designs, providing excellent maneuverability, balance, and blade penetration. This design provides solid lateral stability and better cylinder positions for constant pryout independent of blade height.

Load Sensing Hydraulics

Field-proven, load-sensing hydraulics respond to operating requirements by automatically and continually adjusting hydraulic power to maximize work tool efficiency.

Cat Blades

Semi-Universal, Straight, and Angle Blade designs feature a strong box-section to stand up to the most severe applications. Heavy moldboard construction and hardened bolt-on cutting edges and end bits add strength and durability.

Multi-Shank Ripper

A multi-shank parallelogram style ripper is offered with curved or straight ripper shanks.

Winch

A single lever control actuates both clutch and brake functions to help improve operator efficiency. See your Cat dealer for available winch options.

Rear Counterweight

Optimize balance for backing up steep slopes or increasing performance in heavy dozing applications. Rear counterweights are recommended if another rear attachment is not specified.

Drawbar

The D6T can be equipped with a drawbar for retrieving other equipment or pulling work tools such as disks, compactors, or chopper wheels. Optional implement towing arrangements allow for quick setup of a hydraulically controlled towed scraper.



Serviceability and Customer Support

When uptime counts



Easy Service Access

The D6T is designed with conveniently located, grouped service points and wide engine compartment access panels to help you reduce maintenance time and cost.

Power train oil filter and pressure taps are remote-mounted in the right-hand fender. Quick disconnect fittings allow for fast diagnosis of the power train and hydraulic oil systems.

The engine oil filter is easily accessed on the right side of the engine compartment. An optional quick oil change attachment can further reduce maintenance time.

The water separator, located just inside the engine access panel, functions as the primary fuel filter, just ahead of the secondary fuel filter. A standard electric priming pump on the primary filter reduces the effort required to prime the system.

Scheduled Oil Sampling Analysis (S-O-SSM)

Preventive maintenance through Scheduled Oil Sampling is made easier through live sampling ports for the engine oil, power train hydraulics and coolant. The ports are color coded for easy identification of each system.

Renowned Cat Dealer Support

Only Cat machines come with the industry's best sales and service support – the Cat dealer network. From helping you choose the right machine to ongoing maintenance, your Cat dealer provides the best in sales and service. Manage your costs with preventive maintenance programs like Custom Track Service and guaranteed maintenance contracts. Stay productive with best-in-class parts availability. Your Cat dealer can even help with operator training to help you boost your profits.

And when it's time for replacement, your Cat dealer can help you save even more with Genuine Cat Remanufactured parts. Remanufactured power train and hydraulic components cost less, but come with the same warranty and reliability as new products. Talk with your Cat dealer to learn more about reducing waste and saving money through Cat Remanufacturing.

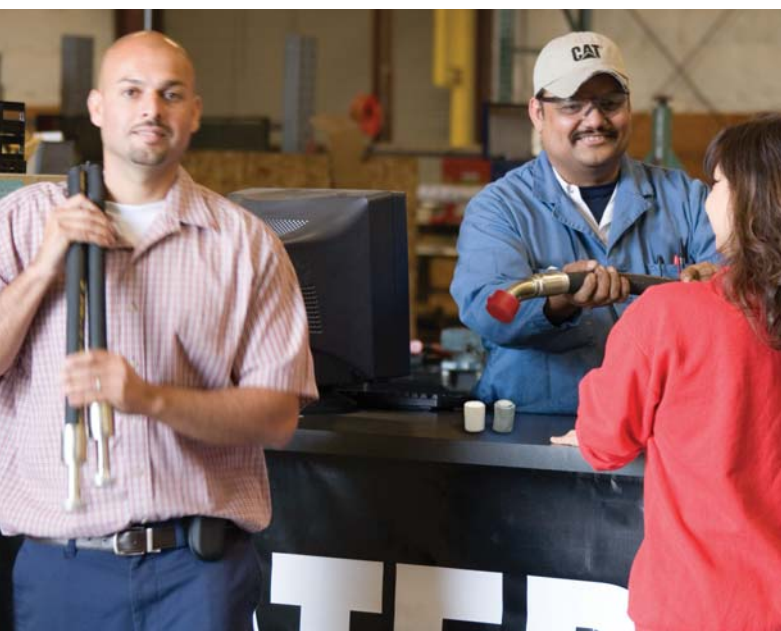

Engine – STD

| | | |
|------------------|--------------|---------------------|
| Engine Model | Cat C9 ACERT | |
| Engine Power | | |
| Maximum Power | | |
| SAE J1995 | 168 kW | 225 hp |
| ISO 14396 | 166 kW | 223 hp |
| ISO 14396 Metric | 226 hp | |
| Net Power | | |
| SAE J1349 | 138 kW | 185 hp |
| ISO 9249 | 138 kW | 185 hp |
| ISO 9249 Metric | 188 hp | |
| Bore | 112 mm | 4.4 in |
| Stroke | 149 mm | 5.9 in |
| Displacement | 8.8 L | 537 in ³ |

Engine – XL/LGP

| | | |
|------------------|--------------|---------------------|
| Engine Model | Cat C9 ACERT | |
| Engine Power | | |
| Maximum Power | | |
| SAE J1995 | 181 kW | 243 hp |
| ISO 14396 | 179 kW | 240 hp |
| ISO 14396 Metric | 243 hp | |
| Net Power | | |
| SAE J1349 | 149 kW | 200 hp |
| ISO 9249 | 149 kW | 200 hp |
| ISO 9249 Metric | 203 hp | |
| Bore | 112 mm | 4.4 in |
| Stroke | 149 mm | 5.9 in |
| Displacement | 8.8 L | 537 in ³ |

- Meets non-current U.S. EPA Tier 3 or EU Stage IIIA emission standards.
- Engine ratings apply at 1,850 rpm.
- ISO 14396 maximum is at 1,300 rpm.
- Net power advertised is the power available at the engine flywheel when the engine is equipped with a fan at maximum speed, air cleaner, muffler and alternator.
- No deratings required up to 2286 m (7,500 ft) altitude, beyond 2286 m (7,500 ft) automatic derating occurs.

Transmission

| | | | |
|-------------|---------|-----------|----------|
| 5 Speed | 3 Speed | | |
| 1.5 Forward | 1 | 3.8 km/h | 2.33 mph |
| 2.0 Forward | | 5.2 km/h | 3.2 mph |
| 2.5 Forward | 2 | 6.6 km/h | 4.09 mph |
| 3.0 Forward | | 8.5 km/h | 5.3 mph |
| 3.5 Forward | 3 | 11.4 km/h | 7.11 mph |
| 1.5 Reverse | 1 | 4.8 km/h | 3 mph |
| 2.0 Reverse | | 6.6 km/h | 4.1 mph |
| 2.5 Reverse | 2 | 8.4 km/h | 5.22 mph |
| 3.0 Reverse | | 10.9 km/h | 6.8 mph |
| 3.5 Reverse | 3 | 14.6 km/h | 9.04 mph |

Service Refill Capacities

| | | |
|-------------------------|---------|----------|
| Fuel Tank | 424 L | 112 gal |
| Cooling System | 76.8 L | 20.3 gal |
| Engine Crankcase | 28 L | 7.4 gal |
| Power Train | 145.7 L | 38.5 gal |
| Final Drives (each) | 13.6 L | 3.6 gal |
| Roller Frames (each) | 24.6 L | 6.5 gal |
| Pivot Shaft Compartment | 5 L | 1.3 gal |
| Hydraulic Tank | 51.5 L | 13.6 gal |

Weights

| | | |
|------------------|-----------|-----------|
| Operating Weight | | |
| STD A-Blade | 19 969 kg | 44,024 lb |
| STD SU-Blade | 19 429 kg | 42,834 lb |
| XL A-Blade | 20 661 kg | 45,550 lb |
| XL SU-Blade | 20 449 kg | 45,082 lb |
| LGP S-Blade | 22 039 kg | 48,588 lb |
| Shipping Weight | | |
| STD A-Blade | 16 266 kg | 35,860 lb |
| STD SU-Blade | 16 266 kg | 35,860 lb |
| XL A-Blade | 17 050 kg | 37,589 lb |
| XL SU-Blade | 17 050 kg | 37,589 lb |
| LGP S-Blade | 18 811 kg | 41,471 lb |

- Operating Weight includes blade, lubricants, coolant, full fuel tank, standard track, ROPS/FOPS cab, drawbar and operator.
- Shipping Weight includes lubricants, coolant, ROPS/FOPS cab, standard track and 10% fuel.

Hydraulic Controls – Pump

| | | |
|---------------------------------------|-----------|--------------|
| RPM at rated Engine Speed – Implement | 1,965 rpm | |
| RPM at rated Engine Speed – Steering | 2,625 rpm | |
| Pump Output – Implement | 189 L/min | 49.9 gal/min |
| Pump Output – Steering | 179 L/min | 47.3 gal/min |
| Lift Cylinder Flow | 189 L/min | 49.9 gal/min |
| Tilt Cylinder Flow | 80 L/min | 21.1 gal/min |
| Ripper Cylinder Flow | 189 L/min | 49.9 gal/min |

Hydraulic Controls – Main Relief Valve

| | | |
|------------------------------|------------|-----------|
| Pressure Setting – Steering | 41 700 kPa | 6,048 psi |
| Pressure Setting – Implement | 21 700 kPa | 3,147 psi |

Hydraulic Controls – Maximum Operating Pressure

| | | |
|------------------|------------|-----------|
| Bulldozer – Lift | 19 300 kPa | 2,799 psi |
| Bulldozer – Tilt | 19 300 kPa | 2,799 psi |
| Ripper | 19 300 kPa | 2,799 psi |

Ripper

| | | |
|---|---------------------|-------------|
| Type | Fixed Parallelogram | |
| Number of Pockets | 3 | |
| Overall Beam Width | 2202 mm | 87 in |
| Beam Cross Section | 216 × 254 mm | 8.5 × 10 in |
| Maximum Clearance Raised (under tip, pinned in bottom hole) | 511 mm | 20.1 in |
| Maximum Penetration | 500 mm | 19.7 in |
| Maximum Penetration Force | 6603 kg | 14,557 lb |
| Pryout Force | 9134 kg | 20,137 lb |
| Weight – With One Shank | 1634 kg | 3,606 lb |
| Each Additional Shank | 74 kg | 163 lb |

D6T Specifications

Winch

| | | |
|-----------------------------------|-----------------------|-----------|
| Winch Model | PA56 | |
| Maximum bare drum line pull* | 40 750 kg | 89,800 lb |
| Rated bare drum line pull | 26 800 kg | 59,100 lb |
| Winch Model | PA56 Optional Gearing | |
| Maximum bare drum line pull | 40 750 kg | 89,800 lb |
| Rated bare drum line pull | 31 750 kg | 70,000 lb |
| Maximum recommended drum capacity | | |
| Recommended rope (22 mm/0.88 in) | 55 m | 180 ft |
| Optional rope (25 mm/1.0 in) | 50 m | 163 ft |
| Weight | 1180 kg | 2,600 lb |
| Oil refill capacity | 67 L | 17.8 gal |
| Drum diameter | 255 mm | 10 in |
| Increased tractor length | 517 mm | 20.4 in |
| Increased tractor length LGP | 397 mm | 15.6 in |

*Maximum line pull is lesser of actual line pull at maximum PTO output torque or catalog breaking strength of maximum optional size new IWRC IPS wire rope.

D6T Standard Tier 3/Stage IIIA

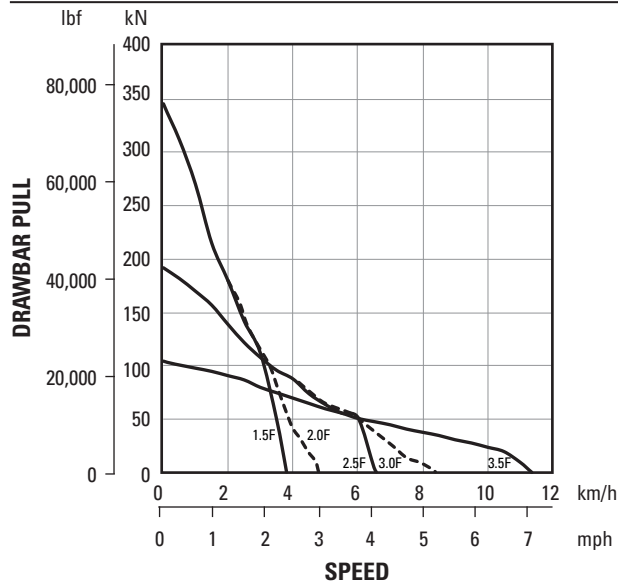

NOTE: Usable pull will depend upon weight and traction of equipped tractor.

D6T XL and LGP Tier 3/Stage IIIA

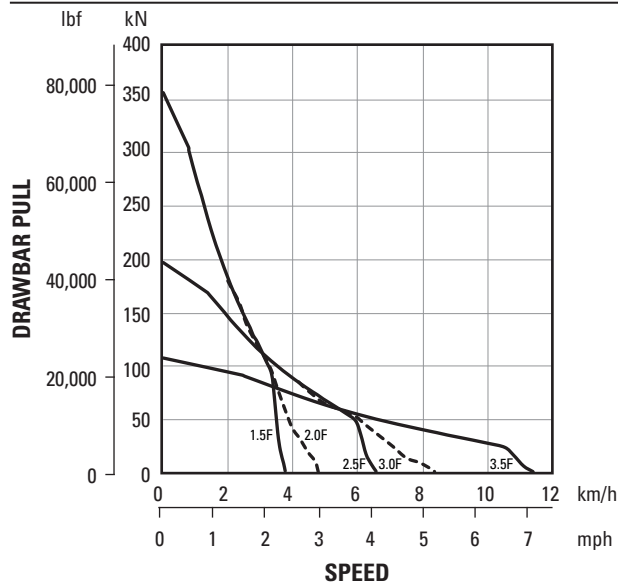

NOTE: Usable pull will depend upon weight and traction of equipped tractor.

Standards

| | |
|-----------|---|
| ROPS/FOPS | ROPS meets criteria ISO 3471:2008. FOPS meets ISO 3449, 2005 Level II. |
| Brakes | Brakes meet the International Standard ISO 10265:2008. |
| Cab | Meets appropriate standards as listed below. |

Standard

- The declared dynamic operator sound pressure level is 76 dB(A) when “ISO 6396:2008” is used to measure the value for an enclosed cab. The measurement was conducted at 70% of the maximum engine cooling fan speed. The sound level may vary at different engine cooling fan speeds. The cab was properly installed and maintained. The measurement was conducted with the cab doors and the cab windows closed. The cab was properly installed and maintained.
- The declared exterior sound power level is 112 dB(A) when the value is measured according to the dynamic test procedures and the conditions that are specified in “ISO 6395:2008.” The measurement was conducted at 70% of the maximum engine cooling fan speed. The sound level may vary at different engine cooling fan speeds.
- Hearing protection may be needed when the machine is operated with an open operator station for extended periods or in a noisy environment. Hearing protection may be needed when the machine is operated with a cab that is not properly maintained, or when the doors and windows are open for extended periods or in a noisy environment.

With Optional Sound Package

- The declared dynamic operator sound pressure level is 75 dB(A) when “ISO 6396:2008” is used to measure the value for an enclosed cab. The measurement was conducted at 70% of the maximum engine cooling fan speed. The sound level may vary at different engine cooling fan speeds. The cab was properly installed and maintained. The measurement was conducted with the cab doors and the cab windows closed. The cab was properly installed and maintained.
- The declared exterior sound power level is 111 dB(A) when the value is measured according to the dynamic test procedures and the conditions that are specified in “ISO 6395:2008.” The measurement was conducted at 70% of the maximum engine cooling fan speed. The sound level may vary at different engine cooling fan speeds.
- Hearing protection may be needed when the machine is operated with an open operator station for extended periods or in a noisy environment. Hearing protection may be needed when the machine is operated with a cab that is not properly maintained, or when the doors and windows are open for extended periods or in a noisy environment.

D6T Specifications

Dimensions

All dimensions are approximate.

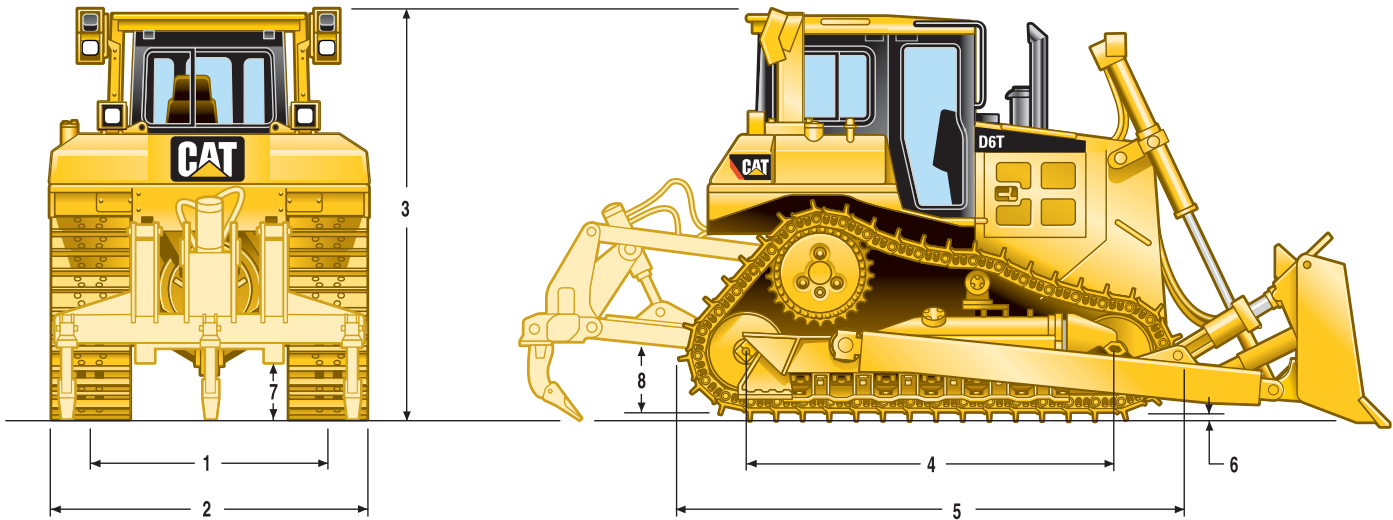

| | STD | | XL | | LGP S | |
|--|--------------------------|-----------------------|--------------------------|-----------------------|--------------------------|-----------------------|
| 1 Track gauge | 1880 mm | 74 in | 1880 mm | 74 in | 2286 mm | 90 in |
| 2 Width of tractor | | | | | | |
| Over trunnions | 2640 mm | 8 ft 8 in | 2640 mm | 8 ft 8 in | 3480 mm | 11 ft 5 in |
| Without trunnions (std. track) | 2440 mm | 8 ft 0 in | 2440 mm | 8 ft 0 in | 3193 mm | 10 ft 6 in |
| 3 Machine height from tip of grouser: | | | | | | |
| Stack | 3143 mm | 10 ft 4 in | 3143 mm | 10 ft 4 in | 3193 mm | 10 ft 6 in |
| ROPS | 3195 mm | 10 ft 6 in | 3195 mm | 10 ft 6 in | 3245 mm | 10 ft 8 in |
| 4 Length of track on ground | 2664 mm | 8 ft 9 in | 2871 mm | 9 ft 5 in | 3275 mm | 10 ft 9 in |
| 5 Length of basic tractor | 3658 mm | 12 ft 0 in | 3860 mm | 12 ft 8 in | 4247 mm | 13 ft 11 in |
| With following attachments add: | | | | | | |
| Drawbar | 217 mm | 8.5 in | 217 mm | 8.5 in | 251 mm | 9.9 in |
| Ripper Multi-Shank (tip at ground line) | 1403 mm | 4 ft 7 in | 1403 mm | 4 ft 7 in | — | — |
| Winch | 517 mm | 1 ft 8 in | 517 mm | 1 ft 8 in | 397 mm | 1 ft 4 in |
| S Blade | 1043 mm | 3 ft 5 in | — | — | 1218 mm | 4 ft 0 in |
| SU Blade | 1235 mm | 4 ft 1 in | 1472 mm | 4 ft 10 in | — | — |
| A Blade | 1147 mm | 3 ft 9 in | 1349 mm | 4 ft 5 in | — | — |
| 6 Height of grouser | 65 mm | 2.6 in | 65 mm | 2.6 in | 65 mm | 2.6 in |
| 7 Ground clearance | 383 mm | 1 ft 3 in | 383 mm | 1 ft 3 in | 433 mm | 1 ft 5 in |
| Track pitch | 203 mm | 8.0 in | 203 mm | 8.0 in | 203 mm | 8.0 in |
| Number of shoes per side | | 39 | | 41 | | 45 |
| Number of rollers per side | | 6 | | 7 | | 8 |
| Standard shoe | 560 mm | 22 in | 560 mm | 22 in | 915 mm | 36 in |
| Ground contact area (std. track) | 2.98 m ² | 4,620 in ² | 3.22 m ² | 4,972 in ² | 5.99 m ² | 9,288 in ² |
| Ground pressure* | 0.614 kg/cm ² | 8.74 psi | 0.623 kg/cm ² | 8.90 psi | 0.362 kg/cm ² | 5.15 psi |
| 8 Drawbar height | 576 mm | 1 ft 11 in | 576 mm | 1 ft 11 in | 626 mm | 2 ft 1 in |
| From ground face of shoe | 511 mm | 1 ft 8 in | 511 mm | 1 ft 8 in | 561 mm | 1 ft 10 in |

*STD, XL with SU blade, with no rear attachments unless otherwise specified.

Weight

All dimensions are approximate.

Bulldozer Specifications

| | S LGP | | SU STD | | SU XL | | A † STD | | A † XL | |
|------------------|---------------------|----------------------|---------------------|----------------------|---------------------|----------------------|---------------------|----------------------|---------------------|----------------------|
| Blade Capacity | 3.75 m ³ | 4.90 yd ³ | 5.61 m ³ | 7.34 yd ³ | 5.61 m ³ | 7.34 yd ³ | 3.93 m ³ | 5.14 yd ³ | 3.93 m ³ | 5.14 yd ³ |
| Width | 4063 mm | 13.33 ft | 3260 mm | 10.66 ft | 3260 mm | 10.66 ft | 4166 mm | 13.66 ft | 4500 mm | 14.75 ft |
| Height | 1101 mm | 44 in | 1412 mm | 56 in | 1412 mm | 56 in | 1155 mm | 45 in | 1155 mm | 45 in |
| Digging Depth | 655 mm | 26 in | 473 mm | 19 in | 459 mm | 18 in | 506 mm | 20 in | 524 mm | 21 in |
| Ground Clearance | 1083 mm | 43 in | 1104 mm | 44 in | 1195 mm | 47 in | 1142 mm | 45 in | 1205 mm | 47 in |
| Maximum Tilt | 701 mm | 28 in | 743 mm | 29 in | 743 mm | 29 in | 408 mm | 16 in | 408 mm | 16 in |
| Weight* | 2836 kg | 6,252 lb | 2699 kg | 5,950 lb | 2973 kg | 6,554 lb | 3050 kg | 6,724 lb | 3150 kg | 6,945 lb |

*Includes push arms, blade, blade tilt cylinder(s), cutting edges and miscellaneous hardware components.

†Angle dozers include two tilt cylinders.

Standard Equipment

Standard equipment may vary. Consult your Cat dealer for details.

POWER TRAIN

- C9 ACERT diesel engine
- Radiator, Aluminum Bar Plate
- Air cleaner, precleaner with stratta tube dust ejector
- Air filter with electronic service indicator
- Aftercooler, air to air (ATAAC)
- Coolant, extended life
- Fan, blower, direct drive
- Final drives, three planet single reduction planetary
- Fuel priming pump, electric
- Muffler, insulated with mitered stack
- Parking brake, electronic
- Prescreener
- Shift management
 - Automatic directional and downshift
 - Controlled throttle, load compensated
- Starting aid, ether, automatic
- Torque divider
- Transmission, electronically controlled powershift 3F/3R speeds
- Turbocharger, wastegate
- Water separator

UNDERCARRIAGE

- SystemOne
- Carrier rollers
- Equalizer bar, heavy duty
- Guards, end track guiding
- Idlers, center tread, lifetime lubricated
- Rollers, lifetime lubricated track
- Track roller frames, tubular
- Track adjusters, hydraulic
- Sprocket rim segments, replaceable

ELECTRICAL

- Alarm, backup
- Alternator, 95 amp, brushless
- Batteries, 2 maintenance free 12V (24V system), heavy duty
- Converter, 12V, 10 amp with 2 outlets
- Connector, diagnostic
- Electric start, 24V
- Horn, forward warning

OPERATOR ENVIRONMENT

- Air conditioner, underhood
- Armrest, adjustable
- Cab, ROPS/FOPS, sound suppressed
- Decelerator pedal
- Differential steering control with touch shift
- Electronic Monitoring System with coolant power train oil, and hydraulic oil temperature, fuel gauge, tachometer, odometer, gear indicator and diagnostic functions
- Foot pads, dash
- Heater
- Hour meter, electronic
- Hydraulic controls, pilot operated with electronic deactivation switch
- Mirror, rearview
- Radio ready
- Seat, adjustable contour suspension
- Seatbelt, retractable 76 mm (3 in)
- Throttle switch, electronic
- Wipers, intermittent

OTHER STANDARD EQUIPMENT

- CD ROM Parts Book
- Engine enclosures, perforated
- Front pull device
- Guards, hinged bottom
- Hood, perforated
- Hydraulics, independent steering and work tool pumps
- Hydraulics, load sensing, dozer lift and tilt
- Oil cooler, hydraulic
- Product link ready
- Radiator doors, louvered, hinged, fan blast deflector
- S·O·S sampling ports
- Tool box
- Vandalism protection for fluid compartments and battery box

Optional Equipment

Optional equipment may vary. Consult your Cat dealer for details.

- Premium Cab Package with cloth air suspension seat and 20 amp converter
- Rear counterweight and drawbar
- Heavy Duty Guard Package
- Efficiency Package with power train oil change system and fast fill fuel system
- Waste Handling Arrangement

POWER TRAIN

- Drains, ecology, power train
- Prescreener
- Grid, radiator core protector
- Fan, ejector
- Fan, reversible
- Precleaner, turbine with screen
- Precleaner, turbine without screen
- Thermal shield arrangement

UNDERCARRIAGE

- Undercarriage, Heavy Duty
- Track pairs
(Standard roller frame, 39 section)
 - Extreme Service (HD)
560 mm (22 in)
 - Extreme Service (SystemOne)
560 mm (22 in)
 - Non-Trapezoidal (SystemOne)
610 mm (24 in)
 - Moderate Service (HD)
560 mm (22 in)
 - Moderate Service (SystemOne)
610 mm (24 in)
- Track pairs
(XL non-VPAT roller frame, 41 section)
 - Extreme Service
(HD) 560 mm (22 in)
 - Extreme Service (HD)
610 mm (24 in), non-trapezoidal
 - Extreme Service (SystemOne)
560 mm (22 in)
 - Extreme Service (SystemOne)
610 mm (24 in), non-trapezoidal
 - Moderate Service (HD)
610 mm (24 in)
 - Extreme Service (HD)
610 mm (24 in), trapezoidal
 - Extreme Service (SystemOne)
560 mm (22 in), center hole

HYDRAULICS

- Hydraulics, ripper

STARTERS, BATTERIES AND ALTERNATORS

- Alternator, 150 amp
- Alternator, 95 amp, ducted
- Heater, engine coolant, 120V
- Batteries, heavy duty and starter

ELECTRICAL

- Lights, five
- Lights, seven
- Lights, eleven
- Lights, sweeps
- Light, warning strobe
- Switch, disconnect, remote mounted

OPERATOR ENVIRONMENT

- Air conditioner, ROPS mounted
- Canopy
- Seat, vinyl
- Camera, rear vision
- Cab, arrangement with screens
- Glass, dual pane and precleaner
- Handles, heavy duty

TECHNOLOGY PRODUCTS

- Security system, machine
- AccuGrade ready, cab
- Blade groups with AccuGrade mounts

GUARDS

Note: Additional guarding may be required for some tractor applications

- Guards
 - Idler seals
 - Crankcase, heavy duty
 - Radiator, hinged
 - Metal hose protection sleeve
 - Final drive, clamshell
 - Final drive seals
 - Fuel tank
 - Precleaner
 - Radiator, HD
 - Radiator, hinged, HD
 - Rear tractor
 - Screen, rear
 - Forestry
 - Track, moderate service
 - Track, full length
 - Track, full
- Striker bars
 - Front
 - Rear
- Striker bar box, rear

COUNTERWEIGHTS AND DRAWBARS

- Counterweight, additional
- Counterweight, rear slab
- Counterweight, rigid short

WINCH

Please see your Cat dealer for Winch options

MISCELLANEOUS

- Paint, black hood and cylinders
- Sweeps

BLADES

- 6SU
- 6S
- 6A
- Blade, Landfill, 6SU

GROUND ENGAGING TOOLS

- Ripper, multi-shank
- Tooth, multi-shank ripper
- Tooth, straight (1, 2 or 3)

For more complete information on Cat products, dealer services, and industry solutions, visit us on the web at www.cat.com

© 2015 Caterpillar
All rights reserved

Materials and specifications are subject to change without notice. Featured machines in photos may include additional equipment. See your Cat dealer for available options.

CAT, CATERPILLAR, SAFETY.CAT.COM, their respective logos, "Caterpillar Yellow" and the "Power Edge" trade dress, as well as corporate and product identity used herein, are trademarks of Caterpillar and may not be used without permission.

VisionLink is a trademark of Trimble Navigation Limited, registered in the United States and in other countries.

AEHQ6742-03 (10-2015)
Replaces AEHQ6742-02
(LACD)

