

430E/430E IT

Backhoe Loaders

CATERPILLAR®



Engine

Engine Model	Cat® C4.4 ACERT® DIT	
Gross Power @ 2,200 rpm – SAE J1995	83 kW	111 hp
Net Power @ 2,200 rpm – SAE J1349	76 kW	102 hp
Net Peak Power @ 1,800 rpm – SAE J1349	77 kW	103 hp

Weights

Operating Weight – Nominal	7125 kg	15,708 lb
Operating Weight – Maximum	11 000 kg	24,251 lb

Backhoe

Dig Depth – Standard	4698 mm	15 ft 5 in
Dig Depth – E-Stick Extended	5951 mm	19 ft 6 in

430E/430E IT Features

World-Class Cab

Standard air suspension seat, extra legroom and more visibility make you feel comfortable – for a safer, more productive work day.

Easy Joystick Control

Ergonomic joystick controls provide smooth operation and low operator effort.

Improved Power Train

Top travel speed of 25 mph/40 km/h so you can get on and off the site faster.

More Work Tools

Do more jobs with one machine. The thumb lets you grip, grab and sort virtually any material.



Contents

Operator Station.....	3
Controls.....	3
Hydraulics	4
Ride Control.....	4
Power Train.....	5
Loader	6
Backhoe.....	7
Serviceability	8
Customer Support.....	8
Technology Products.....	9
Work Tools.....	10
430E/430E IT Specifications.....	11
430E/430E IT Standard Equipment.....	26
430E/430E IT Optional Equipment	27

With standard pilot-operated joystick controls, a more comfortable operator station, extendible stick design and increased performance, the 430E/430E IT lets you get more done with less effort.

Operator Station

Comfort, visibility and style.

Experience a whole new level of comfort with the spacious E-Series operator station. The ergonomic, automotive style enhances the operator environment. A narrow front dash provides excellent visibility to the front bucket. Reduced vibration keeps operator fatigue low. In-cab storage compartment and lockable tool and battery box provides ample space for tools and belongings. The operator station also features an easy-to-read gauge cluster and increased legroom.

Automatic Engine Speed Control

This new feature reduces engine speed when the backhoe is not in use to conserve fuel and lower environmental noise.

Air Suspension Seat

The standard air suspension seat is adjustable for a greater operating range and more comfortable ride. A switch allows the seat to be tailored to support differing body weights. Adjustable seat height accommodates all operators. The deluxe cab air suspension seat also has an adjustable back support, lumbar support, seat cushion extension, seat cushion tilt and vertical and angle adjusting armrests.

Improved Air Conditioning

The improved air conditioning system features enhanced air distribution and performance for a more comfortable work environment. A nearly 20% increase in air flow combined with improved louver locations provide superior operator comfort.

Configurations

The 430E operator station is available in 5 options – ROPS Canopy, ROPS Canopy Plus, Standard Cab, Deluxe Cab and Deluxe Cab with Air Conditioning. See Standard and Optional Equipment for details.



Controls

Reduce fatigue.

Low effort, ergonomic excavator-style joystick controls provide smooth modulation. Thumb rollers provide convenient, fingertip control of auxiliary functions, eliminating pedals on the floor.

One-Touch Low Idle

Located on the right hand joystick, this button reduces engine speed to low idle. This new feature will reduce fuel consumption and improve communication with ground crew.

Pattern Selector

The pattern selector switch, located in the cab, allows the operator to change from excavator to backhoe control pattern simply by pressing a button. This allows the operator to use the pattern they are most familiar with to get more done, faster.



Hydraulics

Load-sensing system matches power to demand.



The 430E has a load-sensing, closed center hydraulic system, which closely matches power and flow to the demand needed by the implements. So whether you're in full trenching mode, or delicately digging around services, you are in control. In applications such as production trenching, speed is important and the system will match the flow needed to get the job done quickly and efficiently. The load-sensing hydraulic system also delivers:

- A cooler hydraulic system
- Better fuel efficiency
- Quieter operation
- Reduced wear on components

Cat XT-3 ES ToughGuard™ hoses combined with Cat couplings and O-ring face seal fittings provide a leak-free system. The 430E also features new flow-sharing hydraulic valves, ensuring proportional flow of oil to all hydraulic cylinders, providing greater control and improving multi-function performance.

Ride Control

Delivers even greater operator comfort.

The optional Ride Control System smoothes the ride in all conditions, including load and carry, highway roading, or simply moving around the job site. It reduces machine loping, providing a smooth and stable ride for increased operator comfort and reduced operator fatigue. The Ride Control option improves material retention in the loader bucket for increased productivity and a cleaner job site.

The system is easily engaged by a switch on the front console. The Ride Control switch has three positions, ON, OFF and AUTOMATIC. In the automatic position, the Ride Control engages automatically as the travel speed increases. At low speed, the system disengages for loading, grading or finishing applications.



Power Train

Built for performance, power, reliability and fuel efficiency.

Cat Engine

The 430E features the Cat® C4.4 DIT (Direct Injection Turbocharged) engine with ACERT® technology and meets all U.S EPA Tier 3/EU Stage IIIa emissions requirements. The increased horsepower and torque rise deliver improved loading and roading performance.

- Electronic engine control provides precise fuel metering for optimized power, response and fuel efficiency.
- The water separator service indicator ensures the operator is alerted when service is necessary.
- Dry-type axial seal air cleaner with automatic, integrated dust ejection system for more efficient pre-separation. Both air cleaner and precleaner functions are incorporated into a single unit mounted under the hood.

Transmission

The Cat standard power shuttle transmission provides four speeds forward and reverse. Hydraulically shifted clutches allow on-the-go direction and travel speed shifts. The optional auto-shift transmission matches gears with grade and load conditions. Top gear is selected with the twist grip control on the steering wheel.

- Hydraulic proportional control valves smooth speed and directional shifts.
- Transmission Kick-Down Switch/Neutralizer allows the operator to downshift through the gears to first.
- Standard Four Wheel Drive (4WD) improves mobility and loader performance in poor underfoot and can be activated on-the-go.
- Maximum roading speed of 40 km/h (25 mph) for faster travel between job sites.
- Cat Rear Axles are designed specifically for demanding backhoe loader applications. Axles feature outboard planetary gear sets for easy serviceability and brake design improvements for longer service life.

Brake Mode Selector

The brake mode selector switch has three positions: two wheel drive, two wheel drive with all wheel braking and four wheel drive. Two wheel drive with all wheel braking provides better tire life while roading and engages the front axle when brakes are applied for improved braking performance.



Loader

Choice of loader linkage to meet your needs.



Caterpillar offers a choice of single tilt or integrated toolcarrier (IT) loader linkage to suit your application requirements. The IT loader controls provide single lever proportional control and fine modulation of the hydraulic work tools. A thumb roller operates auxiliary hydraulic functions such as the multi purpose bucket on the IT machines.



Single Tilt

The standard single tilt loader linkage features strong lift and breakout forces for solid performance in backfilling and truck loading applications.



Integrated Toolcarrier

The optional integrated toolcarrier (IT) loader linkage provides higher breakout forces, as well as parallel lift, for efficient loading and material handling. Integrated toolcarriers are highly versatile and can use a wide range of Cat Work Tools for a variety of applications.



Return-to-Dig

The return-to-dig system reduces loading cycle times by bringing the loader bucket back to the dig position with an easy pull of the lever. By the time the loader bucket is at ground level, the bucket is angled correctly for the next load or cut.



Backhoe

Boom and stick designed for high performance and easy service.

The E-Series backhoe delivers industry-leading digging forces. Serrated edges on the stick provide improved material clamping for clearing and demolition applications. The single pin bucket linkage contributes to best-in-class rotation of 205 degrees for all applications.

E-Stick Design

The optional extendible stick (E-stick) increases reach and dig depth by approximately 1.2 meters (4 feet). The new design delivers increased life and easy in-field adjustment with common hand tools.

Curved Boom

The excavator-style boom is built for optimum performance and durability. The curved design provides additional clearance over obstacles while digging a trench or truck loading. The narrow boom enhances the viewing area to the bucket and trench throughout the entire operating range.

Thumbs

Thumb mounting provisions are standard on every Cat Backhoe Loader for added machine versatility. Hydraulic thumbs are available factory-installed. Mechanical thumbs are available through your Cat Dealer.

Serviceability

Easy access and minimal maintenance requirements maximize uptime.



Convenient service features make maintenance easy, reducing your downtime.

- Tilt-up hood provides convenient access to all engine check points.
- Fill caps are color-coded for quick identification.
- Electronic control modules store fault codes for easy, efficient troubleshooting and maximum uptime.
- S•O•SSM, Coolant Sampling and Technical Analysis help you avoid unscheduled repairs.
- Caterpillar is committed to providing you with a safe work environment. For more information please visit SAFETY.CAT.COMTM.

Customer Support Makes the difference.

Your Cat dealer is ready to assist you with your purchase decision and everything after.

- Financing packages are flexible to meet your needs.
- Your Cat dealer can evaluate the cost to repair, rebuild and replace your machine, so you can make the right choice.
- Nearly all parts are available at your Cat dealer parts counter.
- See your dealer's website or www.cat.com to customize the machine that is right for you using the Build and Quote applications. Also find information on other Cat products, dealer services and industry solutions.



Technology Products

Advanced technologies improve productivity and simplify serviceability.

AccuGrade™ System

The AccuGrade system for backhoe loaders improves digging accuracy and site safety by eliminating the need for manual grade measuring. Both the Site and Laser Reference Systems save time and money in a variety of digging and trenching applications.

Site Reference System

The Site Reference System allows the operator to excavate to pre-determined coordinates. The intuitive software and controls allow the operator to set target grades.

An in-cab display allows the operator to enter slope and dig depth parameters. Easy to read grade indicator and elevation display delivers all system information to the cab for easy viewing by the operator. System includes rugged components built to withstand the harshest environments:

- In-cab display
- Cylinder position sensors
- Swing position sensor
- Inclinometer
- Wiring harnesses

Laser Reference System

The Laser Reference System works with laser transmitters to accurately grade or excavate to a site plan without the use of grade stakes. The Laser System includes all the components of the Site Reference System with the addition of the following:

- Laser receiver
- Electric mast and mount
- Laser wiring harness

Note: Laser transmitter and tripod sold separately

Product Link

Product Link uses GPS technology to provide machine data, including service hours, location, events and diagnostic information, to you through a web-based application or e-mail/pager notification.

Machine Security System

An optional Machine Security System (MSS) that utilizes a programmable key system deters theft, vandalism and unauthorized usage. MSS uses electronically coded keys selected by the customer to limit usage by individuals or time parameters.



Work Tools

Do more jobs with one machine.



Backhoe Work Tools

A large selection of backhoe tools – including a new hydraulic thumb – gives you the flexibility to serve more customers, more profitably.

- Standard Duty, Heavy Duty, Heavy Duty Rock, Pin Lock, Soil Excavation, Coral and Ditch Cleaning Buckets
- Cold Planer
- Hydraulic Hammer
- Auger
- Ripper
- Mechanical and Hydraulic Thumb
- Quick Coupler
- Vibratory Plate Compactor

Loader Work Tools

The versatile loader tool line includes a wide variety of options from angle blades to asphalt cutters:

- General Purpose, Multi Purpose, Side Dump and Light Material Buckets
- Angle Blade
- Broom
- Rake
- Asphalt Cutter
- Loader Forks
- Bale Spear
- Material Handling Arm
- Snow Plow

IT Quick Coupler

The quick coupler allows quick connection to selected work tools. Mechanical work tools can be changed in less than 30 seconds from the comfort of the operator station.

The right bucket makes all the difference

To get top performance from your Cat backhoe loader, be sure your machine is equipped with the proper bucket and tips. The soil excavation bucket provides the best productivity in most conditions.

DRS 230 (Diagonal Retention System)

Heavy-duty bucket teeth are attached with diagonal pins rather than horizontal pins for easy exchange.

Engine

Engine Model (Standard)	Cat® C4.4 ACERT® DIT	
Gross Power – SAE J1995	83 kW	111 hp
Gross Power – ISO 14396	82 kW	110 hp
Net Power – SAE J1349	76 kW	102 hp
Net Power – ISO 9249	77 kW	103 hp
Net Power – EEC 80/1269	77 kW	103 hp
Net Peak Power @ 1,800 rpm – SAE J1349	77 kW	103 hp
Net Peak Power @ 1,800 rpm – ISO 9249	78 kW	105 hp
Net Peak Power @ 1,800 rpm – EEC 80/1269	78 kW	105 hp
Bore	105 mm	4.13 in
Stroke	127 mm	5 in
Displacement	4.4 L	268 in ³
Net Torque Rise @ 1,400 rpm – Standard	43%	
Net Peak Torque @ 1,400 rpm – Standard – SAE J1349	473 N·m	349 lb ft

- Engine meets all U.S. EPA Tier 3/ EU Stage IIIa emissions requirements.
- The net power ratings apply at 2,200 rpm when tested under the specified conditions for the specified standard.
- Net power advertised is the power available at the flywheel when the engine is equipped with fan, air cleaner, muffler and alternator.
- Based on standard air conditions of 25° C (77° F) and 99 kPa (29.32 in) in dry barometer.
- Used 35° API gravity fuel having an LHV of 42 780 kJ/kg (18,390 BTU/lb) when used at 30° C (89° F) (reference a fuel density of 838.9 g/L [7.001 lb/gal]).
- No derating required up to 3000 m (9,843 ft).
- Net torque rise meets SAE J1349.
- Net peak power ratings apply at conditions specified above.

Weights

Operating Weight – Nominal	7125 kg	15,708 lb
Operating Weight – Maximum	11 000 kg	24,251 lb
Cab, ROPS/FOPS	260 kg	573 lb
Auto-Shift	27 kg	60 lb
Transmission		
Ride Control	25 kg	55 lb
Air Conditioning	39 kg	86 lb
Four Wheel Drive	155 kg	342 lb
Loader, IT w/QC	365 kg	805 lb
Extendible Stick (no weights)	275 kg	615 lb
Counterweights (Option 1)	116 kg	255 lb
Counterweights (Option 2)	231 kg	510 lb
Counterweights (Option 3)	488 kg	1,075 lb

- Total gross machine weight not to exceed 11 000 kg (24,251 lb).

Backhoe

Dig Depth – Standard	4698 mm	15 ft 5 in
E-Stick Retracted	4809 mm	15 ft 9 in
E-Stick Extended	5951 mm	19 ft 6 in
Reach from Swing Pivot – Standard	6049 mm	19 ft 10 in
E-Stick Retracted	6154 mm	20 ft 2 in
E-Stick Extended	7247 mm	23 ft 9 in
Bucket Rotation	205 Degrees	
Bucket Dig Force – Standard	70.7 kN	15,892 lb
E-Stick Retracted	69.7 kN	15,680 lb
E-Stick Extended	69.7 kN	15,680 lb
Stick Dig Force – Standard	44.2 kN	9,940 lb
E-Stick Retracted	43.3 kN	9,730 lb
E-Stick Extended	32 kN	7,197 lb
Stick Lift @ 2440 mm (8 ft) – Standard	2755 kg	5,992 lb
E-Stick Retracted	2767 kg	6,100 lb
E-Stick Extended	1966 kg	4,334 lb
Loading Height – Standard	3956 mm	13 ft 0 in
E-Stick Retracted	3912 mm	12 ft 10 in
E-Stick Extended	4520 mm	14 ft 10 in
Loading Reach – Standard	1774 mm	5 ft 10 in
E-Stick Retracted	1948 mm	6 ft 5 in
E-Stick Extended	2916 mm	9 ft 7 in

430E/430E IT Specifications

Loader		
Bucket Capacity – General Purpose	1 m ³	1.31 yd ³
Bucket Width – General Purpose	2406 mm	7 ft 11 in
Dump Height @ Max Angle – Single Tilt	2604 mm	8 ft 6 in
Dump Height @ Max Angle – IT with QC	2539 mm	8 ft 4 in
Dump Reach @ Max Angle – Single Tilt	821 mm	2 ft 8 in
Dump Reach @ Max Angle – IT with QC	799 mm	2 ft 7 in
Dig Depth – Single Tilt	106 mm	4 in
Dig Depth – IT with QC	147 mm	6 in
Lift Capacity @ Full Height – Single Tilt	2937 kg	6,475 lb
Lift Capacity @ Full Height – IT with QC	3162 kg	6,971 lb
Bucket Breakout Force – Single Tilt	46.3 kN	10,401 lb
Bucket Breakout Force – IT with QC	47.5 kN	10,672 lb

Hydraulic System		
Circuit Type	Closed center, load sensing	
Pump Capacity (@ 2,200 rpm)	163 L/min	43 gal/min
System Pressure – Backhoe	24 900 kPa	3,611 psi
System Pressure – Loader	22 800 kPa	3,307 psi
Pump Type	Variable-flow, axial piston	
Steering Type	Front wheel	
Power Steering	Hydrostatic, HMU	
2WD Cylinder – Bore	65 mm	2.6 in
Stroke	120 mm	4.7 in
Rod Diameter	36 mm	1.4 in
4WD Cylinder – Bore	65 mm	2.6 in
Stroke	120 mm	4.7 in
Rod Diameter	36 mm	1.4 in
Brake System	Inboard, oil-immersed, multiple disc	

Power Train		
Power-Shuttle, Forward 1st	6 km/h	3.7 mph
Forward 2nd	9.6 km/h	5.9 mph
Forward 3rd	20 km/h	12 mph
Forward 4th	40 km/h	25 mph
Power-Shuttle, Reverse 1st	6 km/h	3.7 mph
Reverse 2nd	9.6 km/h	5.9 mph
Reverse 3rd	20 km/h	12 mph
Reverse 4th	40 km/h	25 mph
Auto-Shift (opt), Forward 1st	5.9 km/h	3.7 mph
Forward 2nd	10 km/h	5.9 mph
Forward 3rd	20 km/h	12 mph
Forward 4th	27 km/h	17 mph
Forward 5th	42 km/h	26 mph
Auto-Shift (opt), Reverse 1st	5.9 km/h	3.7 mph
Reverse 2nd	13 km/h	7.8 mph
Reverse 3rd	27 km/h	17 mph

- Auto-Shift automatically shifts between second gear and highest selected gear.
- Forward/reverse electric power shuttle is controlled by a conveniently placed, hand operated lever that provides instant direction changes between forward and reverse through power hydraulic clutches.
- Torque converter free-wheel clutch allows the converter stator to free-wheel during high speed, low torque conditions such as roading.
- Single-stage, 2.63:1 stall ratio.
- Travel speeds of two wheel drive backhoe loader at full throttle when equipped with 19.5 × 24 rear tires.

Operating Specifications – Backhoe

Turning Circle: outside, front wheels	8.18 m	26 ft 10 in
Turning Circle: outside, widest loading bucket	10.97 m	36 ft

- ISO 5010.
- 2WD, 4WD (inner wheel not braked).

Service Refills

Cooling System	20.5 L	5.4 gal
Fuel Tank	170 L	45 gal
Engine Oil w/Filter	7.6 L	2 gal
Transmission-Torque Converter, 4WD, Power Shuttle	18.5 L	4.9 gal
Transmission-Torque Converter, 4WD, Auto Shift	19 L	5 gal
Rear Axle	16.5 L	4.4 gal
Rear Axle, Planetaries	1.7 L	0.4 gal
Front Axle, 4WD	11 L	2.9 gal
Front Axle, Planetaries	0.7 L	0.2 gal
Hydraulic System	95 L	25.1 gal
Hydraulic Tank	38 L	10 gal

Standards

Brakes	SAE J/ISO 3450, ISO 3450 1996
Cab – ROPS	SAE J1040 May 1994/ ISO 3741 1994
Cab – FOPS	SAE J/ISO 3449 APR98 LEVEL II and ISO 3449: 1992 LEVEL II
Cab – Sound	ANSI/SAE J1166 Oct 98 is 80 dB (A)
Exterior Sound	SAE J88 JUN86 is 76 dB (A)

Axle Ratings

Front Axle, 2WD, Static	22 964 kg	50,582 lb
Dynamic	9186 kg	20,233 lb
Front Axle, 4WD, Static	22 964 kg	50,582 lb
Dynamic	9186 kg	20,233 lb
Rear Axle, Static	22 964 kg	50,582 lb
Dynamic	9186 kg	20,233 lb
Axle Oscillation	10 Degrees	

- 4WD and 2WD axles are pendulum mounted and permanently sealed and lubricated, requiring no daily maintenance. Also features double-acting steering cylinder with 52° steering angle for increased maneuverability.

Engine Features

- Three-ring pistons made of lightweight, silicon/aluminum alloy for strength and maximum thermal conductivity.
- Forged chrome/molybdenum-steel crankshaft with crankshaft with either induction hardened or nitrocarburized journals.
- Front and rear crankshaft oil seals are “lip” type Viton and PTFE designs featuring an integral dust lip.
- Heat resistant, silicone-chrome steel intake and STELLITE-faced exhaust valves provide long life.
- Cylinder block is high strength, cast iron alloy of deep skirt, monobloc design for increased strength and long life.
- Cylinder head is high strength, cast iron alloy construction with extra duty wall and deck thickness. Intake and exhaust ports are precision cast to promote optimum gas flow.
- Direct injection fuel system provides accurate fuel delivery; remote mounted electric lift pump improves serviceability.
- Dry-type axial seal air cleaner with integral precleaner, automatic dust ejection system, and filter condition indicator.
- Direct electric, 12-volt starting and charging system with 880 CCA Group 31 maintenance free battery.
- Standard glow plug starting aid system for efficient cold weather starting.
- High contact ratio/gear train, peripheral fixed isolation top cover and open deck block design reduce bare engine noise.
- Higher low end torque for better engine/machine performance.

Tires

Choices listed as combination of front/rear tires:

- 12.5/80-18 NHS (12 ply) 1-3 Super Traction/19.5L-24 (12 ply) R4 ATU
- 12.5/80-18 NHS (12 ply) 1-3 Super Traction/21L-24 (16 ply) R4 ATU
- 340/80R 18 XMCL/500/70R 24 XMCL
- 340/80R 18 XMCL/19.5L-R24 (12 ply) R4 ATU

Brakes

Features:

- Brakes meet the following standards: SAE J1473 and ISO 3450 requirements.
- Self-adjusting, completely enclosed and sealed.
- Foot operated brake pedals can be interlocked for roading.
- Parking/secondary brakes are independent of the service brake system. Parking brake is mechanically applied through an adjustable hand lever located on the right console.

430E/430E IT Specifications

Machine Dimensions

	Single Tilt Loader							
	General Purpose (0.96 m ³ /1.25 yd ³)		General Purpose (1.00 m ³ /1.31 yd ³)		General Purpose (1.07 m ³ /1.40 yd ³)		General Purpose (1.15 m ³ /1.50 yd ³)	
	mm	ft/in	mm	ft/in	mm	ft/in	mm	ft/in
(1) Overall length (loader on ground)	7355	24 ft 2 in	7303	24 ft 0 in	7366	24 ft 2 in	7366	24 ft 2 in
Overall transport length	7332	24 ft 1 in	7356	24 ft 2 in	7424	24 ft 4 in	7424	24 ft 4 in
(2) Overall transport height (standard stick)	3577	11 ft 9 in	3866	12 ft 8 in	3866	12 ft 8 in	3866	12 ft 8 in
Overall transport height (extendible stick)	3631	11 ft 11 in	3890	12 ft 9 in	3890	12 ft 9 in	3890	12 ft 9 in
Overall width	2322	7 ft 7 in	2322	7 ft 7 in	2322	7 ft 7 in	2322	7 ft 7 in
(3) Height to top of cab/canopy	2819	9 ft 3 in	2819	9 ft 3 in	2819	9 ft 3 in	2819	9 ft 3 in
(4) Height to top of exhaust stack	2754	9 ft 0 in	2754	9 ft 0 in	2754	9 ft 0 in	2754	9 ft 0 in
Height to loader hinge pin (transport)	360	1 ft 2 in	365	1 ft 2 in	407	1 ft 4 in	407	1 ft 4 in
Ground clearance (minimum)	320	1 ft 1 in	320	1 ft 1 in	320	1 ft 1 in	320	1 ft 1 in
(5) Rear axle centerline to front grill	2705	8 ft 10 in	2704	8 ft 10 in	2704	8 ft 10 in	2704	8 ft 10 in
Front wheel tread gauge	1880	6 ft 2 in	1880	6 ft 2 in	1880	6 ft 2 in	1880	6 ft 2 in
Rear wheel tread gauge	1727	5 ft 8 in	1727	5 ft 8 in	1727	5 ft 8 in	1727	5 ft 8 in
(6) Wheelbase 4WD	2200	7 ft 3 in	2200	7 ft 3 in	2200	7 ft 3 in	2200	7 ft 3 in

Dimensions and performance specifications shown are for machines equipped with 12.5/80-18 SGL front tires, 19.5L-24 IT525 rear tires, ROPS canopy, standard stick with 610 mm (24 inch) standard duty bucket, and 0.96 m³ (1.25 yd³) loader bucket and standard equipment unless otherwise specified.

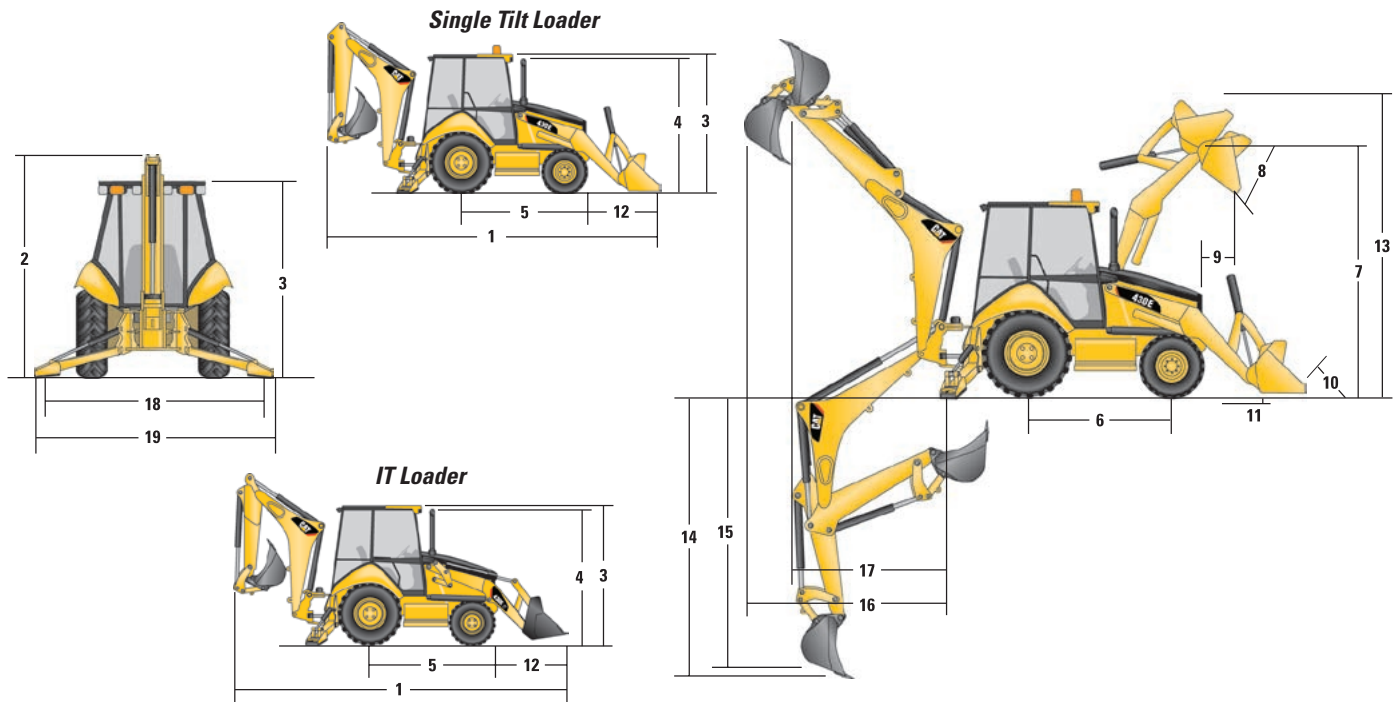

Machine Dimensions

Single Tilt Loader

	Multi Purpose (0.96 m ³ /1.25 yd ³)		Multi Purpose (1.03 m ³ /1.35 yd ³)		Multi Purpose with Forks (1.00 m ³ /1.31 yd ³)		Multi Purpose with Forks (1.07 m ³ /1.40 yd ³)	
	mm	ft/in	mm	ft/in	mm	ft/in	mm	ft/in
(1) Overall length (loader on ground)	7271	23 ft 10 in	7271	23 ft 10 in	7271	23 ft 10 in	7271	23 ft 10 in
Overall transport length	7296	23 ft 11 in	7296	23 ft 11 in	7296	23 ft 11 in	7296	23 ft 11 in
(2) Overall transport height (standard stick)	3577	11 ft 9 in	3577	11 ft 9 in	3577	11 ft 9 in	3577	11 ft 9 in
Overall transport height (extendible stick)	3631	11 ft 11 in	3631	11 ft 11 in	3631	11 ft 11 in	3631	11 ft 11 in
Overall width	2322	7 ft 7 in	2322	7 ft 7 in	2322	7 ft 7 in	2322	7 ft 7 in
(3) Height to top of cab/canopy	2819	9 ft 3 in	2819	9 ft 3 in	2819	9 ft 3 in	2819	9 ft 3 in
(4) Height to top of exhaust stack	2754	9 ft 0 in	2754	9 ft 0 in	2754	9 ft 0 in	2754	9 ft 0 in
Height to loader hinge pin (transport)	412	1 ft 4 in	412	1 ft 4 in	412	1 ft 4 in	412	1 ft 4 in
Ground clearance (minimum)	320	1 ft 1 in	320	1 ft 1 in	320	1 ft 1 in	320	1 ft 1 in
(5) Rear axle centerline to front grill	2705	8 ft 10 in	2705	8 ft 10 in	2705	8 ft 10 in	2705	8 ft 10 in
Front wheel tread gauge	1880	6 ft 2 in	1880	6 ft 2 in	1880	6 ft 2 in	1880	6 ft 2 in
Rear wheel tread gauge	1727	5 ft 8 in	1727	5 ft 8 in	1727	5 ft 8 in	1727	5 ft 8 in
(6) Wheelbase 4WD	2200	7 ft 3 in	2200	7 ft 3 in	2200	7 ft 3 in	2200	7 ft 3 in

IT Loader with Quick Coupler

	General Purpose (0.96 m ³ /1.25 yd ³)		General Purpose (1.00 m ³ /1.31 yd ³)		General Purpose (1.15 m ³ /1.50 yd ³)	
	mm	ft/in	mm	ft/in	mm	ft/in
(1) Overall length (loader on ground)	7464	24 ft 6 in	7412	24 ft 4 in	7455	24 ft 6 in
Overall transport length	7419	24 ft 4 in	7447	24 ft 5 in	7471	24 ft 6 in
(2) Overall transport height (standard stick)	3577	11 ft 9 in	3866	12 ft 8 in	3866	12 ft 8 in
Overall transport height (extendible stick)	3631	11 ft 11 in	3890	12 ft 9 in	3890	12 ft 9 in
Overall width	2322	7 ft 7 in	2322	7 ft 7 in	2322	7 ft 7 in
(3) Height to top of cab/canopy	2819	9 ft 3 in	2819	9 ft 3 in	2819	9 ft 3 in
(4) Height to top of exhaust stack	2754	9 ft 0 in	2754	9 ft 0 in	2754	9 ft 0 in
Height to loader hinge pin (transport)	369	1 ft 3 in	382	1 ft 3 in	359	1 ft 2 in
Ground clearance (minimum)	320	1 ft 1 in	320	1 ft 1 in	320	1 ft 1 in
(5) Rear axle centerline to front grill	2705	8 ft 10 in	2704	8 ft 10 in	2704	8 ft 10 in
Front wheel tread gauge	1880	6 ft 2 in	1880	6 ft 2 in	1880	6 ft 2 in
Rear wheel tread gauge	1727	5 ft 8 in	1727	5 ft 8 in	1727	5 ft 8 in
(6) Wheelbase 4WD	2200	7 ft 3 in	2200	7 ft 3 in	2200	7 ft 3 in

Dimensions and performance specifications shown are for machines equipped with 12.5/80-18 SGL front tires, 19.5L-24 IT525 rear tires, ROPS canopy, standard stick with 610 mm (24 inch) standard duty bucket, and 0.96 m³ (1.25 yd³) loader bucket and standard equipment unless otherwise specified.

430E/430E IT Specifications

Machine Dimensions

	IT Loader with Quick Coupler			
	Multi Purpose (0.96 m ³ /1.25 yd ³)		Multi Purpose (1.03 m ³ /1.35 yd ³)	
	mm	ft/in	mm	ft/in
(1) Overall length (loader on ground)	7372	24 ft 2 in	7372	24 ft 2 in
Overall transport length	7349	24 ft 1 in	7349	24 ft 1 in
(2) Overall transport height (standard stick)	3577	11 ft 9 in	3577	11 ft 9 in
Overall transport height (extendible stick)	3631	11 ft 11 in	3631	11 ft 11 in
Overall width	2322	7 ft 7 in	2322	7 ft 7 in
(3) Height to top of cab/canopy	2819	9 ft 3 in	2819	9 ft 3 in
(4) Height to top of exhaust stack	2754	9 ft 0 in	2754	9 ft 0 in
Height to loader hinge pin (transport)	359	1 ft 2 in	359	1 ft 2 in
Ground clearance (minimum)	320	1 ft 1 in	320	1 ft 1 in
(5) Rear axle centerline to front grill	2705	8 ft 10 in	2705	8 ft 10 in
Front wheel tread gauge	1880	6 ft 2 in	1880	6 ft 2 in
Rear wheel tread gauge	1727	5 ft 8 in	1727	5 ft 8 in
(6) Wheelbase 4WD	2200	7 ft 3 in	2200	7 ft 3 in

Dimensions and performance specifications shown are for machines equipped with 12.5/80-18 SGL front tires, 19.5L-24 IT525 rear tires, ROPS canopy, standard stick with 610 mm (24 inch) standard duty bucket, and 0.96 m³ (1.25 yd³) loader bucket and standard equipment unless otherwise specified.

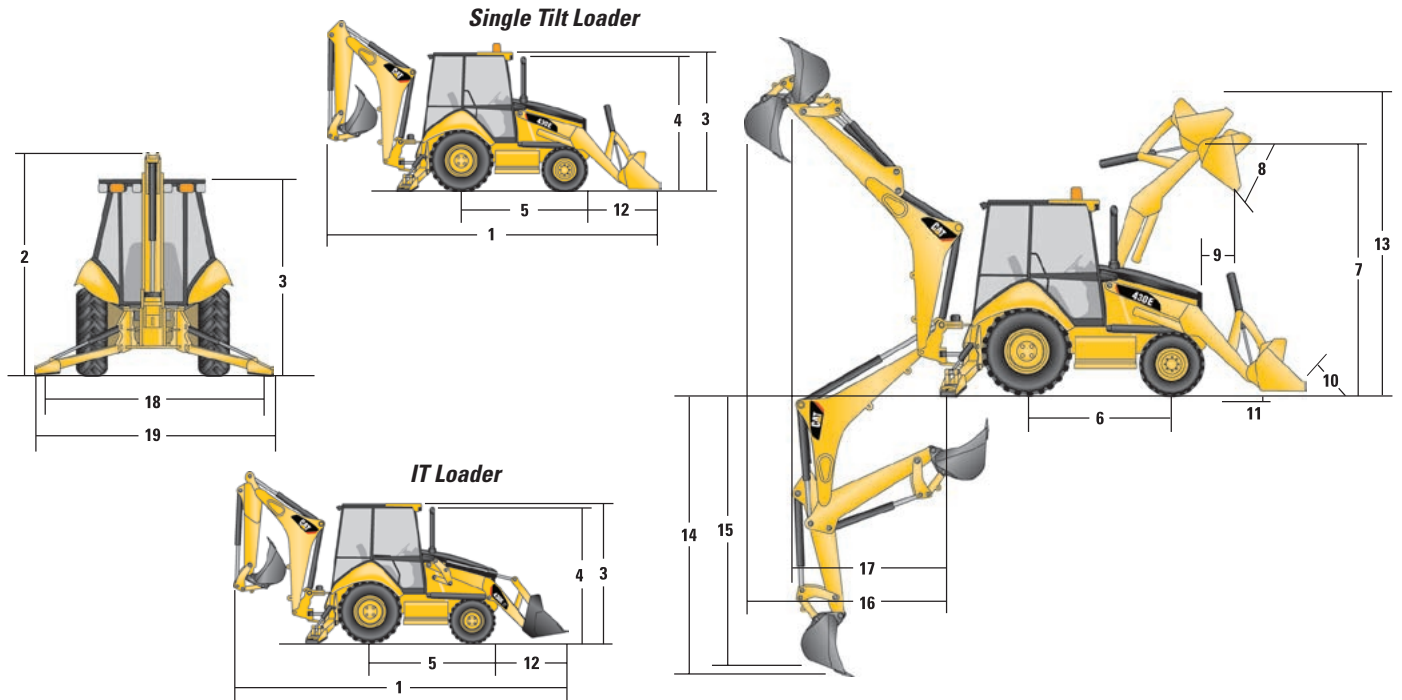

Loader Bucket Dimensions and Performance

	Single Tilt Loader							
	General Purpose (0.96 m ³ /1.25 yd ³)		General Purpose (1.00 m ³ /1.31 yd ³)		General Purpose (1.07 m ³ /1.40 yd ³)		General Purpose (1.15 m ³ /1.50 yd ³)	
Capacity (SAE rated)	0.96 m ³	1.25 yd ³	1.00 m ³	1.31 yd ³	1.07 m ³	1.40 yd	1.15 m ³	1.50 yd ³
Overall bucket width	2262 mm	7 ft 5 in	2406 mm	7 ft 11 in	2262 mm	7 ft 5 in	2406 mm	7 ft 11 in
Lift capacity at maximum height	2811 kg	6,197 lb	2937 kg	6,475 lb	2868 kg	6,323 lb	2849 kg	6,281 lb
Breakout force	44.3 kN	9,973 lb	46.3 kN	10,401 lb	45.1 kN	10,130 lb	44.9 kN	10,091 lb
(7) Maximum hinge pin height	3296 mm	10 ft 10 in	3296 mm	10 ft 10 in	3296 mm	10 ft 10 in	3296 mm	10 ft 10 in
(8) Dump angle at full height	44°		44°		44°		44°	
Dump height at maximum angle	2553 mm	8 ft 7 in	2604 mm	8 ft 7 in	2550 mm	8 ft 4 in	2550 mm	8 ft 4 in
(9) Dump reach at maximum angle	785 mm	2 ft 8 in	821 mm	2 ft 8 in	819 mm	2 ft 8 in	819 mm	2 ft 8 in
(10) Maximum bucket rollback at ground level	39°		39°		40°		40°	
(11) Digging depth	106 mm	4 in	106 mm	4 in	146 mm	6 in	146 mm	6 in
Maximum grading angle	108°		108°		108°		108°	
Width of dozer cutting edge	N/A	N/A	N/A	N/A	N/A	N/A	N/A	N/A
(12) Grill to bucket cutting edge, carry position	1508 mm	4 ft 11 in	1484 mm	4 ft 10 in	1551 mm	5 ft 1 in	1551 mm	5 ft 1 in
(13) Maximum operating height	4177 mm	13 ft 8 in	4193 mm	13 ft 9 in	4237 mm	13 ft 11 in	4237 mm	13 ft 11 in
Jaw opening maximum	N/A	N/A	N/A	N/A	N/A	N/A	N/A	N/A
Bucket jaw clamping force	N/A	N/A	N/A	N/A	N/A	N/A	N/A	N/A
Weight (does not include teeth or forks)	451 kg	994 lb	449 kg	989 lb	459 kg	1,012 lb	479 kg	1,056 lb

	Single Tilt Loader							
	Multi Purpose (0.96 m ³ /1.25 yd ³)		Multi Purpose (1.03 m ³ /1.35 yd ³)		Multi Purpose with Forks (1.00 m ³ /1.31 yd ³)		Multi Purpose with Forks (1.07 m ³ /1.40 yd ³)	
Capacity (SAE rated)	0.96 m ³	1.25 yd ³	1.03 m ³	1.35 yd ³	1.00 m ³	1.31 yd ³	1.07 m ³	1.40 yd ³
Overall bucket width	2279 mm	7 ft 6 in	2425 mm	7 ft 11 in	2279 mm	7 ft 6 in	2425 mm	7 ft 11 in
Lift capacity at maximum height	2615 kg	5,765 lb	2586 kg	5,701 lb	2499 kg	5,508 lb	2470 kg	5,445 lb
Breakout force	46.9 kN	10,547 lb	46.7 kN	10,514 lb	46.0 kN	10,341 lb	45.8 kN	10,308 lb
(7) Maximum hinge pin height	3296 mm	10 ft 10 in	3296 mm	10 ft 10 in	3296 mm	10 ft 10 in	3296 mm	10 ft 10 in
(8) Dump angle at full height	46°		46°		46°		46°	
Dump height at maximum angle	2607 mm	8 ft 7 in	2607 mm	8 ft 7 in	2607 mm	8 ft 7 in	2607 mm	8 ft 7 in
(9) Dump reach at maximum angle	694 mm	2 ft 3 in	694 mm	2 ft 3 in	694 mm	2 ft 3 in	694 mm	2 ft 3 in
(10) Maximum bucket rollback at ground level	40°		40°		40°		40°	
(11) Digging depth	133 mm	5 in	133 mm	5 in	133 mm	5 in	133 mm	5 in
Maximum grading angle	113°		113°		113°		113°	
Width of dozer cutting edge	2262 mm	7 ft 5 in	2406 mm	7 ft 11 in	2262 mm	7 ft 5 in	2406 mm	7 ft 11 in
(12) Grill to bucket cutting edge, carry position	1473 mm	4 ft 10 in	1473 mm	4 ft 10 in	1473 mm	4 ft 10 in	1473 mm	4 ft 10 in
(13) Maximum operating height	4226 mm	13 ft 10 in	4226 mm	13 ft 10 in	4700 mm	15 ft 5 in	4700 mm	15 ft 5 in
Jaw opening maximum	790 mm	2 ft 7 in	790 mm	2 ft 7 in	790 mm	2 ft 7 in	790 mm	2 ft 7 in
Bucket jaw clamping force	55.7 kN	12,521 lb	55.7 kN	12,521 lb	55.7 kN	12,521 lb	55.7 kN	12,521 lb
Weight (does not include teeth or forks)	745 kg	1,642 lb	774 kg	1,706 lb	915 kg	2,017 lb	936 kg	2,064 lb

Dimensions and performance specifications shown are for machines equipped with 12.5/80-18 SGL front tires, 19.5L-24 IT525 rear tires, ROPS canopy, standard stick with 610 mm (24 inch) standard duty bucket, and 0.96 m³ (1.25 yd³) loader bucket and standard equipment unless otherwise specified.

Loader Bucket Dimensions and Performance

	IT Loader with Quick Coupler					
	General Purpose (0.96 m ³ /1.25 yd ³)		General Purpose (1.00 m ³ /1.31 yd ³)		General Purpose (1.15 m ³ /1.50 yd ³)	
Capacity (SAE rated)	0.96 m ³	1.25 yd ³	1.00 m ³	1.31 yd ³	1.15 m ³	1.50 yd ³
Overall bucket width	2262 mm	7 ft 5 in	2406 mm	7 ft 11 in	2406 mm	7 ft 11 in
Lift capacity at maximum height	3056 kg	6,737 lb	3162 kg	6,971 lb	3131 kg	6,903 lb
Breakout force	45.8 kN	10,305 lb	47.5 kN	10,672 lb	46.8 kN	10,525 lb
(7) Maximum hinge pin height	3316 mm	10 ft 11 in	3329 mm	10 ft 11 in	3329 mm	10 ft 11 in
(8) Dump angle at full height	45°		45°		45°	
Dump height at maximum angle	2492 mm	8 ft 2 in	2539 mm	8 ft 4 in	2509 mm	8 ft 3 in
(9) Dump reach at maximum angle	802 mm	2 ft 8 in	799 mm	2 ft 7 in	830 mm	2 ft 9 in
(10) Maximum bucket rollback at ground level	40°		40°		40°	
(11) Digging depth	153 mm	6 in	147 mm	6 in	146 mm	6 in
Maximum grading angle	108°		110°		108°	
Width of dozer cutting edge	N/A	N/A	N/A	N/A	N/A	N/A
(12) Grill to bucket cutting edge, carry position	1595 mm	5 ft 3 in	1575 mm	5 ft 2 in	1598 mm	5 ft 3 in
(13) Maximum operating height	4234 mm	13 ft 11 in	4256 mm	14 ft 0 in	4335 mm	14 ft 3 in
Jaw opening maximum	N/A	N/A	N/A	N/A	N/A	N/A
Bucket jaw clamping force	N/A	N/A	N/A	N/A	N/A	N/A
Weight (does not include teeth or forks)	447 kg	985 lb	444 kg	978 lb	468 kg	1,032 lb

	IT Loader with Quick Coupler			
	Multi Purpose (0.96 m ³ /1.25 yd ³)		Multi Purpose (1.03 m ³ /1.35 yd ³)	
Capacity (SAE rated)	0.96 m ³	1.25 yd ³	1.03 m ³	1.35 yd ³
Overall bucket width	2279 mm	7 ft 6 in	2425 mm	7 ft 11 in
Lift capacity at maximum height	2800 kg	6,174 lb	2771 kg	6,110 lb
Breakout force	44.5 kN	10,020 lb	44.4 kN	9,983 lb
(7) Maximum hinge pin height	3316 mm	10 ft 11 in	3316 mm	10 ft 11 in
(8) Dump angle at full height	45°		45°	
Dump height at maximum angle	2559 mm	8 ft 5 in	2559 mm	8 ft 5 in
(9) Dump reach at maximum angle	748 mm	2 ft 5 in	748 mm	2 ft 5 in
(10) Maximum bucket rollback at ground level	40°		40°	
(11) Digging depth	144 mm	6 in	144 mm	6 in
Maximum grading angle	111°		111°	
Width of dozer cutting edge	2262 mm	7 ft 5 in	2406 mm	7 ft 11 in
(12) Grill to bucket cutting edge, carry position	1526 mm	5 ft 0 in	1526 mm	5 ft 0 in
(13) Maximum operating height	4306 mm	14 ft 2 in	4306 mm	14 ft 2 in
Jaw opening maximum	790 mm	2 ft 7 in	790 mm	2 ft 7 in
Bucket jaw clamping force	55.7 kN	12,521 lb	55.7 kN	12,521 lb
Weight (does not include teeth or forks)	724 kg	1,596 lb	753 kg	1,660 lb

Dimensions and performance specifications shown are for machines equipped with 12.5/80-18 SGL front tires, 19.5L-24 IT525 rear tires, ROPS canopy, standard stick with 610 mm (24 inch) standard duty bucket, and 0.96 m³ (1.25 yd³) loader bucket and standard equipment unless otherwise specified.

Backhoe Dimensions and Performance

	Standard Stick		E-Stick Retracted		E-Stick Extended	
(14) Digging depth, SAE (max.)	4698 mm	15 ft 5 in	4809 mm	15 ft 9 in	5951 mm	19 ft 6 in
(15) Digging depth, 610 mm (2 ft) flat bottom	4672 mm	15 ft 4 in	4783 mm	15 ft 8 in	5925 mm	19 ft 5 in
Reach from rear axle centerline at ground line	7152 mm	23 ft 6 in	7257 mm	23 ft 10 in	8350 mm	27 ft 5 in
(16) Reach from swing pivot at ground line	6049 mm	19 ft 10 in	6154 mm	20 ft 2 in	7247 mm	23 ft 9 in
Maximum operating height	6009 mm	19 ft 9 in	6096 mm	20 ft 0 in	6990 mm	22 ft 11 in
Loading height	3956 mm	13 ft 0 in	3912 mm	12 ft 10 in	4520 mm	14 ft 10 in
(17) Loading reach	1774 mm	5 ft 10 in	1948 mm	6 ft 5 in	2916 mm	9 ft 7 in
Swing arc	180°		180°		180°	
Bucket rotation	205°		205°		205°	
(18) Stabilizer spread, operating position (center)	3310 mm	10 ft 10 in	3310 mm	10 ft 10 in	3310 mm	10 ft 10 in
(19) Stabilizer spread, operating position (outside)	3770 mm	12 ft 4 in	3770 mm	12 ft 4 in	3770 mm	12 ft 4 in
Stabilizer spread, transport position	2322 mm	7 ft 7 in	2322 mm	7 ft 7 in	2322 mm	7 ft 7 in
Bucket dig force	70.7 kN	15,892 lb	69.7 kN	15,680 lb	69.7 kN	15,680 lb
Stick dig force	44.2 kN	9,940 lb	43.3 kN	9,730 lb	32.0 kN	7,197 lb

Dimensions and performance specifications shown are for machines equipped with 12.5/80-18 SGL front tires, 19.5L-24 IT525 rear tires, ROPS canopy, standard stick with 610 mm (24 inch) standard duty bucket, and 0.96 m³ (1.25 yd³) loader bucket and standard equipment unless otherwise specified.

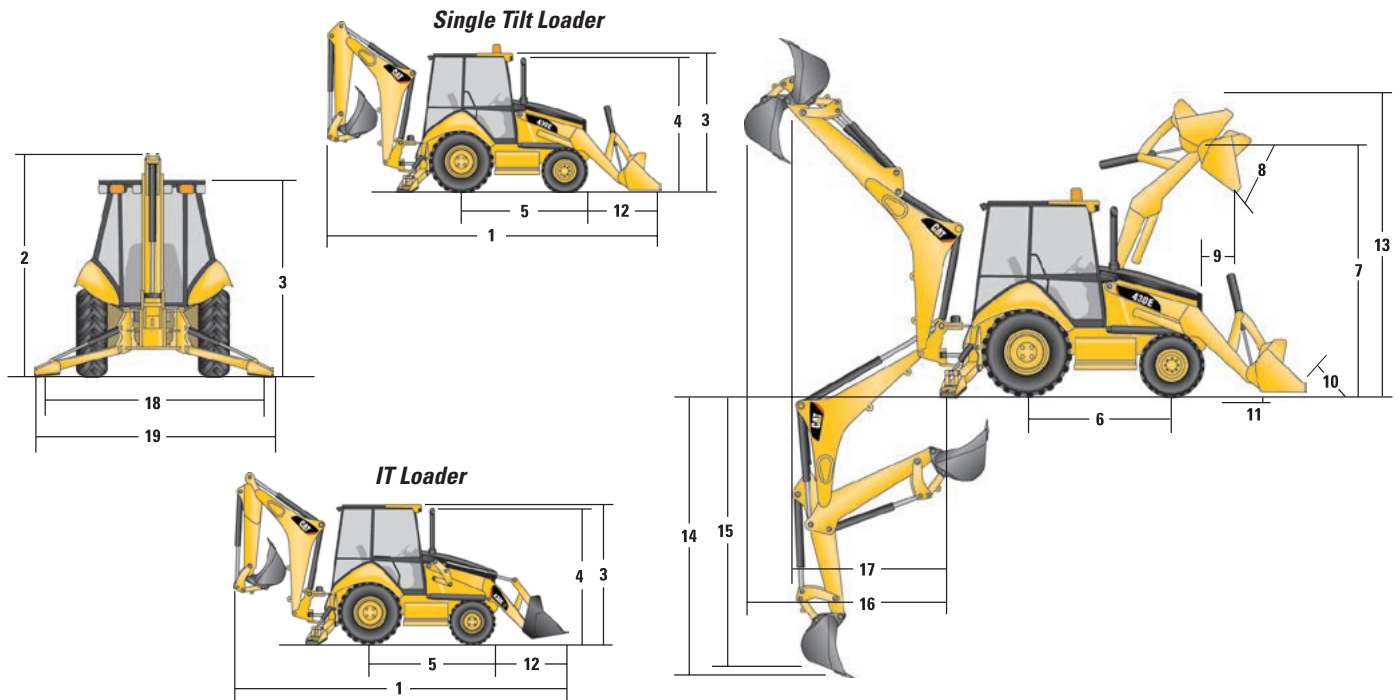

430E/430E IT Specifications

Dimensions with Forks

Fork Tine Length	1070 mm/3 ft 6 in		1220 mm/4 ft 0 in		1370 mm/4 ft 10 in	
Operating load (SAE J1197)	2403 kg*	5,298 lb*	2258 kg	4,978 lb	2089 kg	4,604 lb
SAE load center	535 mm	1 ft 9 in	610 mm	2 ft 0 in	685 mm	2 ft 3 in
Operating load (CEN 474-4)	2428 kg	5,353 lb	2406 kg	5,304 lb	2382 kg	5,252 lb
CEN load center	500 mm	1 ft 8 in	500 mm	1 ft 8 in	500 mm	1 ft 8 in
(1) Overall length (forks on ground)	7857 mm	25 ft 9 in	8007 mm	26 ft 3 in	8157 mm	26 ft 9 in
(2) Reach at ground (from grill to heel of fork)	985 mm	3 ft 3 in	985 mm	3 ft 3 in	985 mm	3 ft 3 in
(3) Maximum reach (from grill to heel of fork)	1427 mm	4 ft 8 in	1427 mm	4 ft 8 in	1427 mm	4 ft 8 in
(4) Fork height at maximum reach	1458 mm	4 ft 9 in	1458 mm	4 ft 9 in	1458 mm	4 ft 9 in
(5) Reach at maximum height (from grill to heel of fork)	665 mm	2 ft 2 in	665 mm	2 ft 2 in	665 mm	2 ft 2 in
(6) Maximum fork height	3238 mm	10 ft 7 in	3238 mm	10 ft 7 in	3238 mm	10 ft 7 in
(7) Maximum fork depth (below ground level)	20 mm	1 in	20 mm	1 in	20 mm	1 in

*Tip limited.

Dimensions and performance specifications shown are for machines equipped with 12.5/80-18 SGL front tires, 19.5L-24 IT525 rear tires, ROPS canopy, standard stick with 610 mm (24 inch) standard duty bucket, and 0.96 m³ (1.25 yd³) loader bucket and standard equipment unless otherwise specified.

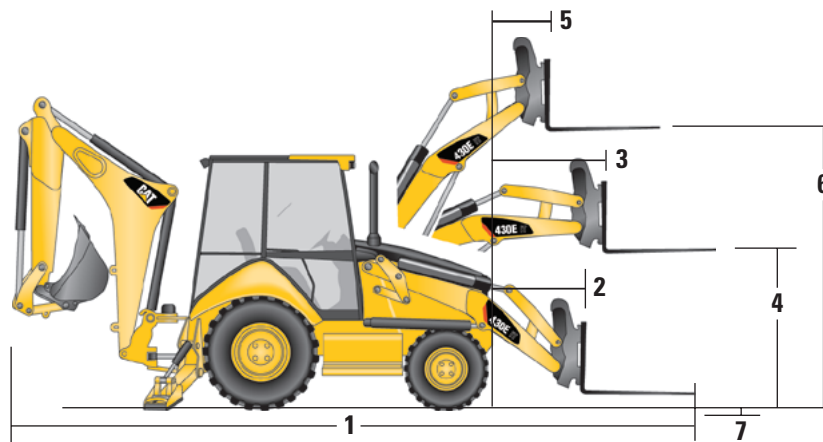

Dimensions with Material Handling Arm

Material Handling Arm Position	Retracted		Mid-Position		Extended	
Operating load (SAE J1197 and CEN 474-4)*	906 kg	1,998 lb	572 kg	1,261 lb	418 kg	921 lb
Overall length, maximum	8948 mm	29 ft 4 in	9948 mm	32 ft 8 in	10 947 mm	35 ft 11 in
(1) Reach at maximum depth (from machine nose)	585 mm	1 ft 11 in	585 mm	1 ft 11 in	585 mm	1 ft 11 in
(2, 3, 4) Maximum depth	1998 mm	6 ft 7 in	2996 mm	9 ft 10 in	3996 mm	13 ft 1 in
(5, 6, 7) Maximum reach (from machine nose)	3147 mm	10 ft 4 in	4145 mm	13 ft 7 in	5145 mm	16 ft 11 in
(8) Height at maximum reach	1549 mm	5 ft 1 in	1549 mm	5 ft 1 in	1549 mm	5 ft 1 in
(9, 10, 11) Reach at maximum height (from machine nose)	1462 mm	4 ft 10 in	2000 mm	6 ft 7 in	2541 mm	8 ft 4 in
(12, 13, 14) Maximum height	5051 mm	16 ft 7 in	5892 mm	19 ft 4 in	6733 mm	22 ft 1 in

*Hydraulically limited.

Dimensions and performance specifications shown are for machines equipped with 12.5/80-18 SGL front tires, 19.5L-24 IT525 rear tires, ROPS canopy, standard stick with 610 mm (24 inch) standard duty bucket, and 0.96 m³ (1.25 yd³) loader bucket and standard equipment unless otherwise specified.

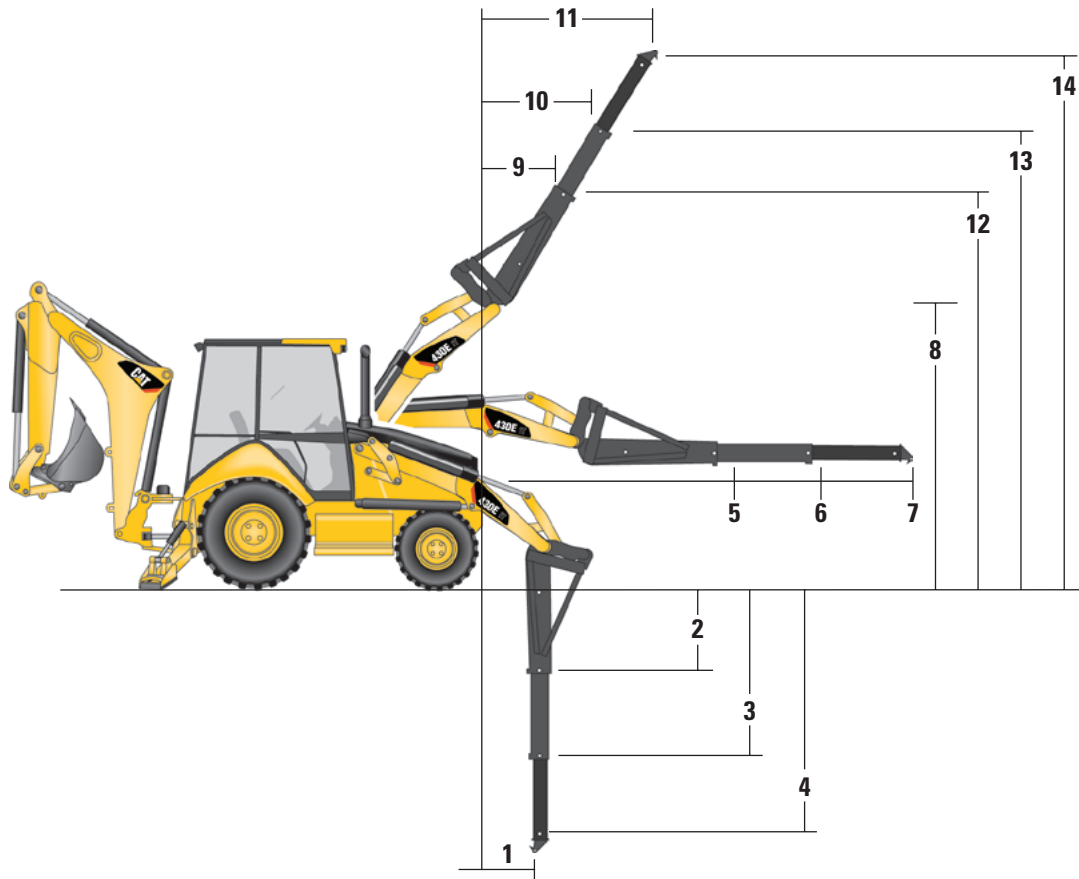

430E/430E IT Specifications

Backhoe Lift Capacity

Cat 430E/430E IT Standard Stick

Boom Lifting	kg	lb
1	1469	3,232
2	1740	3,828
3	1906	4,193
4	1901	4,183
5	1857	4,086
6	1801	3,962
7	1715*	3,773*
8	1648*	3,626*
9	1619*	3,562*
10	1577	3,469
11	1530	3,365
12	1488	3,273
13	1452	3,195
14	1427	3,139
15	1423	3,130
16	1507	3,315
17	1587	3,492
Stick Lifting	kg	lb
18	2436	5,359
19	2615	5,754
20	2684	5,906
21	2629	5,783
22	2755	6,061
23	3139*	6,907*
24	5259*	11,571*
25	5368*	11,809*

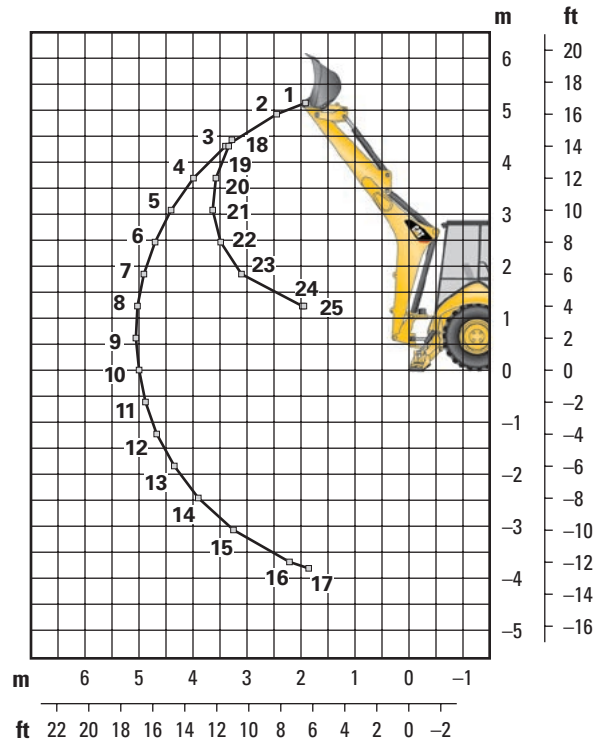

Lift Capacities are over-end values. Machine equipped with 4WD, OROPS, 1.00 m³ (1.31 yd³) general purpose bucket, and 116 kg (255 lb) counterweight.

*Indicates lift capacity is stability limited.

Backhoe Lift Capacity

Cat 430E/430E IT Extendible Stick – Retracted

Boom Lifting		
	kg	lb
1	1214	2,670
2	1505	3,311
3	1639	3,606
4	1635	3,598
5	1595	3,510
6	1543	3,395
7	1488	3,273
8	1433	3,152
9	1380	3,036
10	1330	2,927
11	1284	2,826
12	1243	2,735
13	1208	2,657
14	1181	2,598
15	1172	2,578
16	1224	2,693
17	1345	2,959
Stick Lifting		
	kg	lb
18	2142	4,711
19	2348	5,165
20	2400	5,280
21	2350	5,170
22	2457	5,406
23	2817	6,197
24	4270	9,394
25	5815*	12,793*

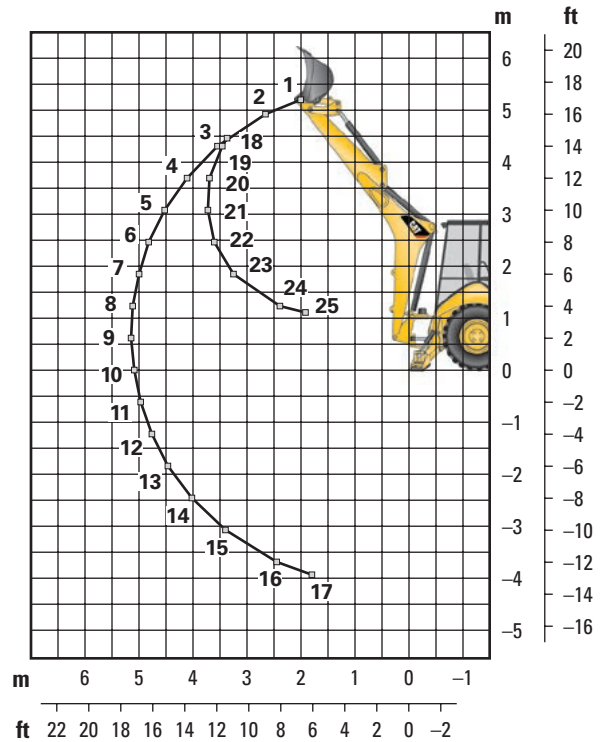

Lift Capacities are over-end values. Machine equipped with 4WD, OROPS, 1.00 m³ (1.31 yd³) general purpose bucket, and 116 kg (255 lb) counterweight.

Extendible stick includes 488 kg (1,075 lb) counterweight.

*Indicates lift capacity is stability limited.

430E/430E IT Specifications

Backhoe Lift Capacity

Cat 430E/430E IT Extendible Stick – Extended

Boom Lifting		
	kg	lb
1	657	1,446
2	993	2,185
3	1106	2,433
4	1143	2,514
5	1148	2,525
6	1138	2,503
7	1120	2,464
8	1098	2,416
9	1075	2,364
10	1051	2,312
11	1028	2,261
12	1006	2,213
13	987	2,171
14	971	2,135
15	959	2,110
16	956	2,102
17	966	2,125
18	1011	2,223
19	1224	2,694
Stick Lifting		
	kg	lb
20	1187	2,612
21	1266	2,786
22	1553	3,416
23	1634	3,595
24	1615	3,553
25	1650	3,630
26	1752	3,854
27	1960	4,312
28	2419	5,322
29	4631	10,187
30	5624*	12,373*

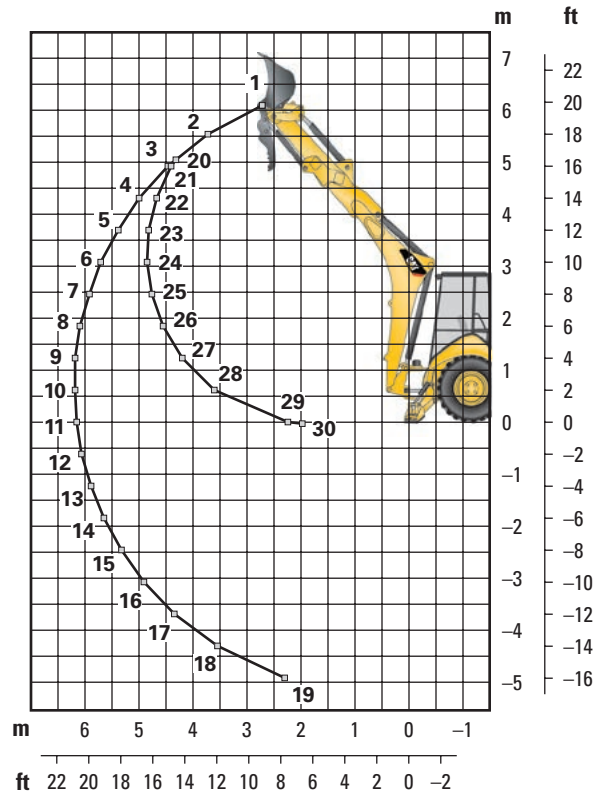

Lift Capacities are over-end values. Machine equipped with 4WD, OROPS, 1.00 m³ (1.31 yd³) general purpose bucket, and 116 kg (255 lb) counterweight. Extendible stick includes 488 kg (1,075 lb) counterweight.

*Indicates lift capacity is stability limited.

Counterweights

Minimum Counterweight Recommendations

Standard Stick

Loader Bucket	Power Train	Single-Tilt		IT Loader w/QC	
		kg	lb	kg	lb
GP	4WD	231	510	no counterweight	
MP	4WD	no counterweight		no counterweight	
Forks	4WD	N/A	N/A	no counterweight	
Material Handling Arm	4WD	N/A	N/A	no counterweight	

Extendible Stick

Loader Bucket	Power Train	Single-Tilt		IT Loader w/QC	
		kg	lb	kg	lb
GP	4WD	488	1,075	488	1,075
MP	4WD	231	510	116	255
Forks	4WD	N/A	N/A	no counterweight	
Material Handling Arm	4WD	N/A	N/A	231	510

Backhoe Buckets

With weld on adapters and pin-on teeth

Standard Duty

Width		Rated Capacity		Weight		No. of Teeth
mm	in	L	ft ³	kg	lb	
305	12	78	2.8	97	213	3
457	18	118	4.2	115	253	4
610	24	175	6.2	132	290	5
762	30	233	8.2	147	323	5
914	36	292	10.3	165	363	6

Heavy Duty

Width		Rated Capacity		Weight		No. of Teeth
mm	in	L	ft ³	kg	lb	
305	12	78	2.8	105	231	3
406	16	105	3.7	127	279	3
457	18	118	4.2	129	284	4
610	24	175	6.2	151	332	5
762	30	233	8.2	167	367	5
914	36	292	10.3	189	416	6

Soil Excavation

Width		Rated Capacity		Weight		No. of Teeth
mm	in	L	ft ³	kg	lb	
457	18	181	6.4	153	336	4
610	24	241	8.5	179	395	5
762	30	320	11.3	197	434	5
914	36	380	13.4	223	491	6

Heavy Duty Rock

Width		Rated Capacity		Weight		No. of Teeth
mm	in	L	ft ³	kg	lb	
305	12	70	2.5	120	265	3
457	18	127	4.5	150	331	4
610	24	198	7.0	175	386	5
762	30	255	9.5	195	430	5
914	36	311	11.5	210	463	6

Coral

Width		Rated Capacity		Weight		No. of Teeth
mm	in	L	ft ³	kg	lb	
305	12	60	2.1	134	295	4
457	18	100	3.5	155	341	6
610	24	140	4.9	182	402	8
762	30	190	6.7	210	463	10

430E/430E IT Standard Equipment

Standard equipment may vary. Consult your Caterpillar dealer for details

Air cleaner	Filters, spin-on: fuel, engine oil, transmission oil, water separator, hydraulic fluid	Open circuit breather
Alarm, back-up	Flashing hazard/signal lights	Pattern changer, in cab
Automatic Engine Speed Control (AESC)	Floor mat	Power receptacle, 12V, internal and external
Backhoe position footrests	Four wheel drive with driveshaft guard	Power steering, hydrostatic
Battery, maintenance-free, 880 CCA	Gauges: coolant temperature, fuel level, tachometer, hour meter, torque converter oil temperature	Radio installation kit
Battery disconnect switch	Ground level fuel fill	Rubber impact strips on radiator guard
Boom transport lock	High ambient cooling package	Seat belt, retractable (51 mm/2 in)
Brace, lift cylinder	Hydraulic hose, XT™-3 ES	Service harness
Brake, secondary parking	Hydraulic oil cooler	Stabilizer shoes, grouser type
Brakes, hydraulically boosted, oil disc, dual pedals, interlocking	Indicators: air cleaner service, water separator service, brake on, engine coolant, hydraulic oil level sight gauge, oil pressure	Seat, air suspension, fabric or vinyl cover, with armrest
Bucket level indicator	Instrument panel lights	Stabilizer controls, pilot operated
Canopy, ROPS/FOPS	Joystick controls: pilot operated, excavator-style with pattern changer	Starting system, glow plugs
Cat cushion swing system	Key start/stop system	Storage compartment, internal
Coat hook	Lights, working (4 front, 4 rear)	Stop and tail lights
Coolant/Antifreeze, extended life	Loader, self-leveling, return-to-dig and transmission disconnect switch	Swing transport lock
Counterweight, bumper	Lunch box holder	Tilt steering wheel
Dome light (cab only)	Mirror, rear view	Tires, see page 13
Differential lock	One-touch low idle	Toolbox, external, lockable
Engine, Cat® C4.4 ACERT® DIT (Direct Injection Turbocharged)		Torque converter
Engine enclosure		Throttles, hand and foot
Face seals, O-ring		Transmission, four speed, syncromesh
Fan, suction and guard		Transmission neutralizer switch
Fast reversing shuttle, all gears		Transport tie-downs
Fenders, rear		Warning horn, electric

Optional equipment may vary. Consult your Caterpillar dealer for details

	kg	lb		kg	lb		kg	lb
AccuGrade™ Site Reference System for Backhoe Loaders	19	42	Battery, additional, 880 CCA	25	55	Hydraulic lines		
AccuGrade Laser Reference System for Backhoe Loaders	48	105	Cab, deluxe	225	495	Combo, Std Stick	27	59
Attachments, backhoe			Cab, deluxe with A/C	263	579	Combo, E-Stick	27	59
Mechanical Quick Coupler			Cab, standard	225	495	One-way, E-Stick	22	48
D and E-Series buckets	75	165	Canopy Plus, ROPS	15	33	Loader, IT with hydraulic QC and pilot loader control	338	744
C-Series buckets	75	165	Coolant, additional protection, -50° C (-58° F)	0	0	Machine Security System	1	2
D, E and Deere buckets	75	165	Counterweights			Product Link	4	9
D, E and Case buckets	80	176	116 kg (255 lb)	116	255	Ride Control	22	48
Hydraulic thumb	139-157	306-345	231 kg (510 lb)	231	510	Rotating beacon		
Attachments, front loader			488 kg (1,075 lb)	488	1,075	Magnetic mount	5	11
General purpose buckets			Cutting edge, bolt-on, two piece	70	154	Seat belt, 75 mm (3 in)	0	0
0.96 m³ (1.25 yd³)	452	994	Fenders, 4WD, front	12	26	Stabilizers, available with guards		
1.00 m³ (1.31 yd³)	462	1,016	Fenders, rear extensions	1	2	Street	37	81
1.07 m³ (1.4 yd³)	473	1,041	Guards			Reversible	38	84
Multi purpose buckets			Boom protection plate	18	39	Sticks		
1.0 m³ (1.3 yd³)	557	1,225	Stabilizer, rock	31	68	Extendible	255	561
1.0 m³ (1.3 yd³) w/ forks	884	1,945	Hydraulic valves, loader (3rd valve for GP, MP or Quick Coupler)	27	59	Teeth, loader bucket	45	99
1.1 m³ (1.4 yd³)	742	1,632	Hydraulic valves, backhoe			Transmission, auto-shift	25	55
1.1 m³ (1.4 yd³) w/ forks	908	1,998	5th Function	5	11	Vandalism protection		
Carriage, fork	218	480	6th Function	5	11	Gauge cover	1	2
Material handling arm	425	953				Padlocks	1	2
						Hood lock	0	0

430E/430E IT Backhoe Loaders

For more complete information on Cat products, dealer services, and industry solutions, visit us on the web at www.cat.com

© 2008 Caterpillar Inc.
All rights reserved

AEHQ6012 (09-2008)
Replaces AEHQ5686-02

Materials and specifications are subject to change without notice. Featured machines in may include additional equipment. See your Caterpillar dealer for available options.

CAT, CATERPILLAR, SAFETY.CAT.COM their respective logos, "Caterpillar Yellow" and the POWER EDGE trade dress, as well as corporate and product identity used herein, are trademarks of Caterpillar and may not be used without permission.

CATERPILLAR®