



Cat[®] 257B Series 2

MULTI TERRAIN LOADER

FEATURES:

The Cat[®] 257B Series 2 Multi Terrain Loader, with its vertical lift design, delivers extended reach and lift height for quick and easy truck loading. Its suspended undercarriage system provides superior traction, flotation and the ability to work in a wide range of underfoot conditions. The 257B Series 2 features the following:

- **Ergonomic operator station** features easy to use pilot operated joystick controls for reduced operator fatigue and increased productivity.
- **High performance power train** provides high engine horsepower and torque, allowing part-throttle operation for lower sound levels and fuel consumption.
- **Advanced hydraulic system** is designed for maximum power and reliability. High flow hydraulic system is available for applications that demand maximum work tool performance.
- **Single level suspension undercarriage** provides low ground pressure, stability, high traction and fast travel.
- **Easy routine maintenance** helps reduce machine downtime for greater productivity.
- **Broad range of performance matched Cat[®] Work Tools** make the Cat Multi Terrain Loader the most versatile machine on the jobsite.

Specifications

Engine

Engine Model	Cat [®] C2.2 T	
Gross Power SAE J1995	45.5 kW	61 hp
Net Power SAE 1349	42 kW	56 hp
Displacement	2.2 L	134 in ³
Stroke	100 mm	3.9 in
Bore	84 mm	3.3 in

Weights

Operating Weight	3607 kg	7,952 lb
------------------	---------	----------

Power Train

Travel Speed (Forward or Reverse)	11.2 km/h	6.9 mph
-----------------------------------	-----------	---------

Hydraulic System

Hydraulic Flow – Standard:		
Loader Hydraulic Pressure	23 000 kPa	3,335 psi
Loader Hydraulic Flow	60 L/min	15.6 gal/min
Hydraulic Power	22.7 kW	30.4 hp
Hydraulic Flow – High Flow:		
Max. Loader Hydraulic Pressure	23 000 kPa	3,335 psi
Max. Loader Hydraulic Flow	100 L/min	26 gal/min

Operating Specifications

Rated Operating Capacity:		
35% Tipping Load	848 kg	1,870 lb
50% Tipping Load	1134 kg	2,500 lb
Tipping Load	2424 kg	5,344 lb
Breakout Force, Tilt Cylinder	1793 kg	3,954 lb
Ground Contact Area	1.14 m ²	1,770 in ²
Ground Pressure	31 kPa	4.5 psi

Cab

ROPS	SAE J1040 MAY94, ISO 3471:1994	
FOPS	SAE J/ISO 3449 APR98 Level I, ISO 3449:1992 Level I	
FOPS Level II	SAE J/ISO 3449 APR98 Level II, ISO 3449:1992 Level II (optional)	

Service Refill Capacities

Cooling System	10 L	2.6 gal
Engine Crankcase	10 L	2.6 gal
Fuel Tank	84 L	22.2 gal
Hydraulic System	55 L	14.5 gal
Hydraulic Tank	35 L	9.2 gal

257B Series 2 Multi Terrain Loader

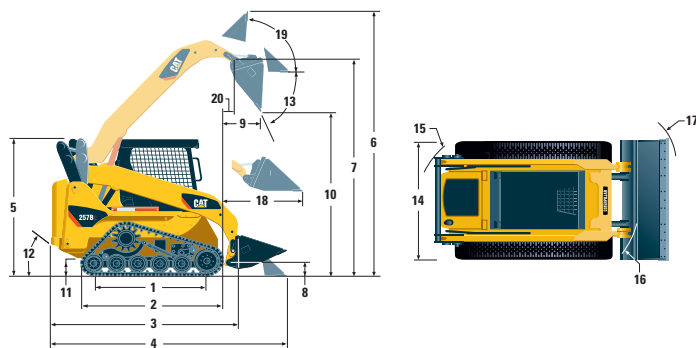

Dimensions

1 Length of Track on Ground	1499 mm	59 in
2 Overall Length of Track	1899 mm	75 in
3 Length w/o Bucket	2701 mm	106 in
4 Length w/Bucket on Ground	3490 mm	137 in
5 Height to Top of Cab	2022 mm	80 in
6 Maximum Overall Height	3963 mm	156 in
7 Bucket Pin Height at Maximum Lift	3018 mm	119 in
8 Bucket Pin Height at Carry Position	234 mm	9.3 in
9 Reach at Maximum Lift and Dump	790 mm	31 in
10 Clearance at Maximum Lift and Dump	2278 mm	90 in
11 Ground Clearance	257 mm	10 in
12 Departure Angle	37°	
13 Maximum Dump Angle	50°	
14 Vehicle Width	1676 mm	66 in
15 Turning Radius from Center – Machine Rear	1479 mm	58.2 in
16 Turning Radius from Center – Coupler	1696 mm	66.8 in
17 Turning Radius from Center – Bucket	2197 mm	86.5 in
18 Maximum Reach w/Arms Parallel to Ground	1388 mm	54.6 in
19 Rack Back Angle at Maximum Height	86.9°	
20 Bucket Pin Reach at Maximum Lift	357 mm	14.1 in

MANDATORY EQUIPMENT

- Hydraulics, Standard or High Flow
- Quick Coupler, Mechanical or Hydraulic
- Seat Belt, 50 mm (2 in) or 75 mm (3 in)

COMFORT PACKAGE (must select one of the following)

- Open ROPS (C0): *Static Seat*
- Open ROPS (C1): *Suspension Seat, Cup Holder*
- Enclosed ROPS (C2): *C1 + Heater, Cab Door, Side Windows, Cab Debris Barrier*
- Enclosed ROPS (C3): *C2 + Air Conditioner*

CONTROL PACKAGE (must select one of the following)

- Control Package 1: *On/Off Auxiliary Hydraulics Basic*
- Control Package 2: *Proportional Auxiliary Hydraulics Deluxe*
- Control Package 3: *High Flow Hydraulics*

STANDARD EQUIPMENT

ELECTRICAL

- 12 volt Electrical System
- 85 ampere Alternator
- Ignition Key Start/Stop Switch
- Lights: *Gauge Backlighting, Two Rear Tail Lights, Two Adjustable Front and Rear Halogen Lights, Dome Light*

OPERATOR ENVIRONMENT

- Gauges: *Fuel Level, Hour Meter*
- Operator Warning System Indicators: *Air Filter Restriction, Alternator Output, Armrest Raised/Operator Out of Seat, Engine Coolant Temperature, Engine Oil Pressure, Glow Plug Activation, Hydraulic Filter Restriction, Hydraulic Oil Temperature, Parking Brake Engaged*
- Vinyl Seat
- Pull Down Ergonomic Contoured Armrest
- Control Interlock System, when operator leaves seat or armrest raised: *Hydraulic System Disables, Hydrostatic Transmission Disables, Parking Brake Engages*
- ROPS Cab, Open, Tilt Up
- FOPS, Level I
- Top and Rear Windows
- Headliner, Deluxe
- Floor Mat
- Interior Rear View Mirror
- 12 volt Electric Socket
- Horn
- Backup Alarm

POWER TRAIN

- Cat® C2.2 T Tier 4 Interim Compliant Diesel Engine
- Air Cleaner, Dual Element, Radial Seal
- S-O-SSM Sampling Valves, Engine Oil and Hydraulic Oil
- Filters: Spin on, Hydraulic
- Filters: Bayonet-type, Fuel and Water Separator
- Tilt Up Radiator/Hydraulic Oil Cooler
- Muffler, Standard
- Spring Applied, Hydraulically Released, Wet Multi Disc Parking Brakes
- Hydrostatic Transmission

OTHER

- Engine Enclosure, Lockable
- Extended Life Antifreeze, -36° C (-33° F)
- Machine Tie Down Points (4)
- Support, Lift Arm
- Hydraulic Oil Level Sight Gauge
- Radiator Coolant Level Sight Gauge
- Radiator, Expansion Bottle
- Cat® ToughGuard™ Hose
- Auxiliary, Hydraulics, Continuous Flow
- Heavy Duty, Flat Faced Quick Disconnects
- Split D-Ring to Route Work Tool Hoses Along Side of Left Lift Arm
- Electrical Outlet, Beacon
- Belly Pan Cleanout

OPTIONAL ATTACHMENTS

- Counterweight, increases rated operating capacity 20 kg (45 lb)
- Beacon, Rotating
- Engine Block Heater – 120V or 240V
- Oil, Hydraulic, Cold Operation
- Paint, Custom
- Heavy Duty Battery, 850 CCA

For more complete information on Cat products, dealer services, and industry solutions, visit us on the web at www.cat.com

AEHQ5900-01 (11-07)

© 2007 Caterpillar
All Rights Reserved
Printed in U.S.A.

Materials and specifications are subject to change without notice. Featured machines in photos may include additional equipment. See your Caterpillar dealer for available options.

CAT, CATERPILLAR, SAFETY.CAT.COM, their respective logos, "Caterpillar Yellow" and the POWER EDGE trade dress, as well as corporate and product identity used herein, are trademarks of Caterpillar and may not be used without permission.

CATERPILLAR®