

# CS423E

Vibratory Soil  
Compactor



**Stage II Compliant**

Cat® 3054C Diesel Engine

Gross Power 62 kW/83 hp

Compaction Width 1676 mm

Centrifugal Force

High 134 kN

Low 67 kN

Operating Weight (with ROPS/FOPS Cab) 6990 kg

## Introducing the CS423E.

*Designed to meet your smooth drum compaction needs.*

*Engineered for optimum results, the CS423E features a Caterpillar® 3054C engine rated at 62 kW (83 hp). The CS423E is sized to minimize operating costs and meet the needs of the majority of applications from site preparation to compacting sub-bases for parking lots or roadways. An optional padfoot shell kit increases versatility and a list of several other attachments provides you with exceptional performance in a wider range of applications.*

---

### Engine

Powered by the 62 kW (83 hp) Caterpillar® 3054C diesel engine, the CS423E provides exceptional performance on flat or aggressive terrain. The 3054C engine meets Stage II emission regulations. **pg. 4**

---

### Dual Propel Pumps

The exclusive dual pump propel system provides a separate balanced hydraulic flow to both the rear drive axle and the front drum drive motor. This system enables the operator to achieve unmatched gradeability and maintain machine control while compacting on a grade. Dual pumps also minimize drum and wheel spin-out in low traction conditions. **pg. 4**

---

### Vibratory System

A pod-style weight housing ensures peak vibratory performance and minimal service. The pod is replaceable and features bearing lubrication change intervals of 3 years/3000 hours. **pg. 5**

---

### Padfoot Conversion Kit

An optional two-piece padfoot conversion kit expands the application range to work in either cohesive or semi-cohesive materials. Simple changing procedure minimizes your conversion time. **pg. 8**

---

### Operator's Station

- ✓ Based on the 500D-Series Soil Compactors operator's station, the 400E-Series Soil Compactors feature exceptional operator comfort and unmatched visibility to drum and tire edges. A propel lever wrist rest, grouped control gauges and conveniently located control switches enhance operator productivity and reduce operator fatigue. Four heavy-duty isolation mounts provide a smooth ride. **pg. 6**



✓ *New feature*

### **Setting industry standards... again.**

*Based upon the industry-proven reputation of the Caterpillar® 400C-Series Soil Compactors, the new 400E-Series establishes new standards for productivity, comfort and serviceability in the soil compaction industry. The 400E-Series compactors continue to provide exceptional reliability, quality and gradeability that you've come to expect from Caterpillar.*



---

#### **Visibility**

- ✓ The one-piece sloped hood design provides exceptional operator visibility to the outside edge of the rear tires and to the rear of the machine. **pg. 6**

---

#### **Cab**

- ✓ The cab on the 400E-Series Soil Compactors is engineered to provide the operator unparalleled viewing area and comfort. Integrated, factory installed air conditioning is optional. The cab may be an option in some areas and standard in others. Consult your dealer for specifics. **pg. 7**

---

#### **Serviceability**

- ✓ The newly designed one-piece fiberglass hood tilts forward to allow access to the engine and daily maintenance points. Sealed-for-life bearings in the articulation hitch never need to be greased. Engine lubrication change interval of 500 hours. The operator's station tilts forward to provide access to the hydraulic pumps. **pg. 9**

### ***Performance and reliability you can trust.***

*Caterpillar® E-Series Soil Compactors are the benchmark of the soil compactor industry. Durable Cat power train, field-proven hydraulic and vibratory systems and the world's largest and most dedicated dealer support system ensure the 400E-Series Soil Compactors will provide maximum utilization.*

## Caterpillar® 3054C Diesel Engine

*Industry-proven Caterpillar technology designed to provide performance, reliability and fuel economy.*

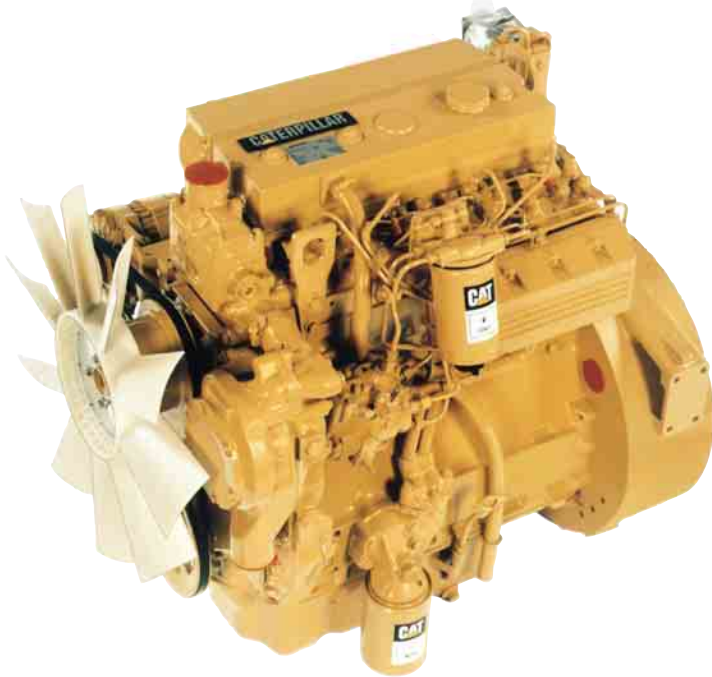

**Direct injection fuel system.** Adjustment-free direct injection fuel system provides individually metered high-pressure, direct injection of fuel for maximum efficiency.

**High displacement-to-power ratio.** It ensures long life and exceptional reliability.

**Oil cooler.** Engine oil cooler keeps the engine running cool and maintains the oil integrity.

**Oil pump.** Low-mounted oil pump for quicker start-up lubrication.

**Fuel filters and water separator.** Dual fuel filters and water separator offer superior protection for the unit injection system.

**Air inlet heater.** It helps cold weather starting.

**Emission requirements.** This engine meets EU directive 97/68/EC Stage II emission requirements.

## Dual Pump Propel System

*Superior tractive effort and gradeability for outstanding productivity and machine control in demanding environments.*

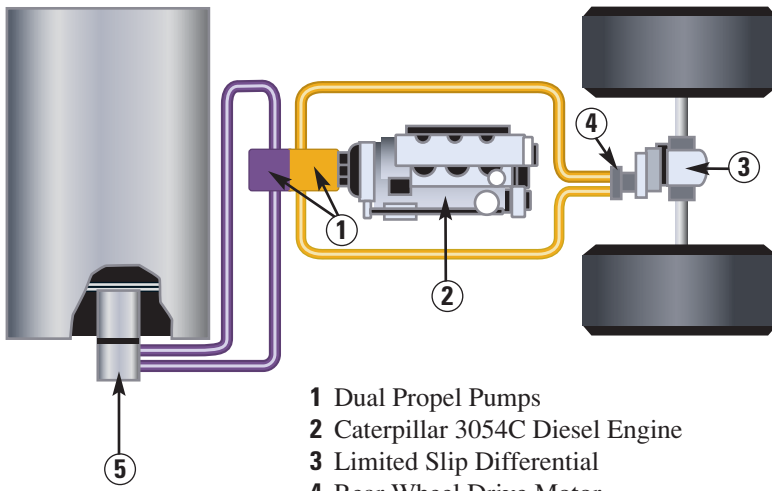

- 1 Dual Propel Pumps
- 2 Caterpillar 3054C Diesel Engine
- 3 Limited Slip Differential
- 4 Rear Wheel Drive Motor
- 5 Drum Drive Motor

**Dual propel pumps.** Dual propel pumps provide separate, balanced flow to the rear wheel axle and the drum drive motors. Provides superior gradeability and increases tractive effort in soft material.

**Limited slip differential.** It provides balanced tractive effort to both rear wheels.

**Speed ranges.** Two speed ranges for versatile operation. Low speed range for vibratory operation and maximum torque when grade climbing. High speed range moves machine quickly over longer distances.

**Valves.** Flushing valves in each propel circuit help keep hydraulic oil cool and clean.

**Travel Speed.** High travel speed up to 11.5 km/h.

## Vibratory System

*The pod-style vibratory system delivers superior compactive force while offering serviceability advantages.*

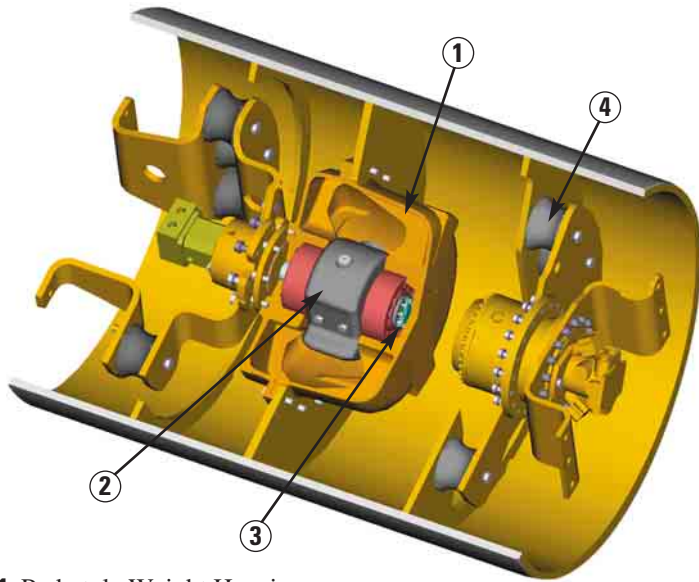

- 1 Pod-style Weight Housing
- 2 Patented Eccentric Weight
- 3 Heavy-duty Bearings
- 4 Isolation Mounts

**Pod-style weight housing.** It is assembled and sealed at the factory to ensure cleanliness, longer bearing life and easier field exchange or service.

**Dual amplitude.** It works efficiently in a wider range of applications. Changeable from the operator's station.

**Vibratory frequency.** Vibratory frequency of 31.9 Hz for maximum compaction results. Optional variable frequency available with a frequency range from 23.3-31.9 Hz .

**Heavy-duty bearings.** Large heavy-duty bearings for the eccentric weight shaft allow higher frequency for greater force.

**Service interval.** 3 year/3000 hour vibratory bearing lube service interval reduces maintenance.

**Isolation mounts.** Improved isolation mounts allow more force to be transmitted to the ground and less vibration to the operator.

## Patented Eccentric Weights

*Reliable dual amplitude selection and innovative design ensure precise performance.*

High Amplitude

Low Amplitude

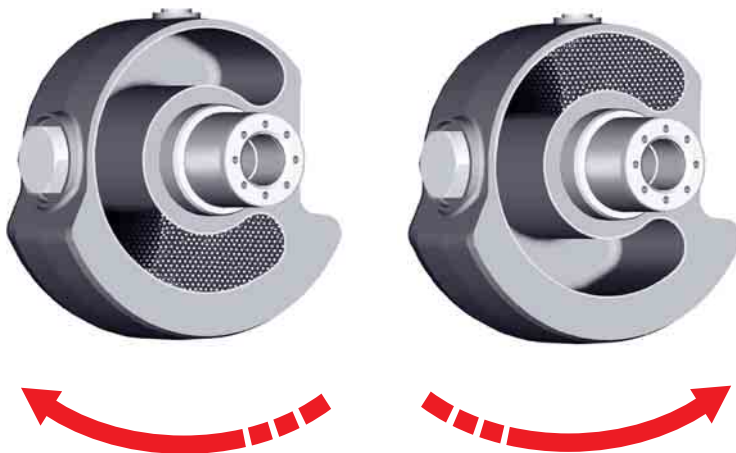

**Amplitude selection.** Positive amplitude selection is accomplished when the spherical steel shot is repositioned inside the hollow eccentric weight. Direction of weight shaft rotation determines amplitude.

**Improved reliability.** It ensures no chance of steel shot wedging together. System reliability is superior to swinging mechanical weights.

**Simplified control.** The simplified control from the operator's station with a selection switch on the operator's console.

---

## Operator's Station

*Ergonomically designed for maximum operator productivity while offering visibility and unmatched comfort.*



**Steering console and operational gauges.** Steering console with foot-rests providing excellent operator's comfort.

**Single lever control.** The Single lever control for propel and vibratory On/Off provides simple and low effort operation. A padded adjustable wrist rest helps reduce operator fatigue.

**Seat.** Comfortable and durable seat has adjustable fore/aft position, bottom cushion height, suspension stiffness and flip-up arm rests.

**Isolated operator's station.** The isolated operator's station with heavy-duty rubber mounts reduce machine vibration transmitted to the operator.

**Floor mat.** Rubber floor mat helps further isolate the operator from machine vibration and noise.

---

## One-Piece Hood Design

*The new one-piece fiberglass hood design provides excellent service access and exceptional operator visibility.*



**Visibility.** The visibility to the drum and tire edges are exceptional. The sloped hood allows the operator to see obstacles measuring 1 meter high located 1 meter to the rear of the machine. Excellent visibility in all directions increases productivity for working near obstructions, in trenches, or maneuvering around the job site.

**One-piece hood.** One-piece fiberglass hood tilts forward to provide unrestricted access to the engine and all service points.

**Gas charged struts.** The gas charged struts easily lifts hood to provide exceptional access to the engine and cooling system.

**Sound levels.** Low sound levels for the operator and the ground crew due to the one-piece hood design and revised cooling air flow through the rear mounted radiator.

## ROPS/FOPS Cab

*Optional cab can increase machine utilization in extreme environment conditions and the ergonomic design emphasizes comfort, visibility and easy operation.*

**Cab.** The cab is a spacious and comfortable work environment that includes large windows, more interior room with storage areas, better ergonomics and a dramatic reduction in interior sound levels.

**Windshield.** Full-length glass windshield provides exceptional visibility to the drum.

**Mirrors.** Two exterior rear view mirrors, front and rear working lights included with cab.

**Wipers.** Windshield wipers on front and rear windows allow clear vision in adverse conditions.

**Windows.** Slide-open side windows for cross ventilation.

**Climate control.** The climate control with standard heater and defroster for maximum operator comfort. Optional air conditioning helps keep the cab cool and comfortable.



---

## Padfoot Shell Kit

*Optional padfoot shell kit expands the application range of the CS423E to work in either cohesive or semi-cohesive material.*



**Shell kit.** Two-piece shell kit features a total of 84 pads with a pad height of 90 mm. Each half of the shell kit weighs 453 kg and includes a special bumper for a quick conversion.

**Machine application range.** Expands machine application range to work effectively in either cohesive or semi-cohesive material.

**Compaction specification.** Meets compaction specification quickly with no loss in compactive performance in semi-cohesive material.

**Easy adaptation.** Kit can be quickly and easily removed or installed for adaptation to specific job conditions with no special tooling required.

---

## Articulation and Oscillation Hitch

*The hitch area, proven reliable on 500D-Series Soil Compactors, offers improved durability, reliability and simplified service.*

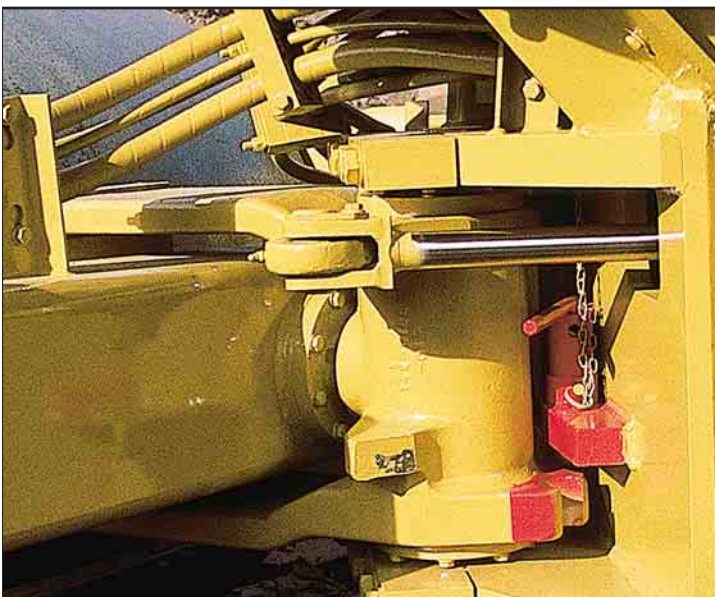

**Hitch area.** It is structurally reinforced and joined by two hardened steel pins for improved service life.

**Articulation pin.** Vertical articulation pin permits 37 degrees steering in either direction.

**Oscillation pin.** Horizontal oscillation pin allows up to 15 degrees drum oscillation.

**Roller bearings.** Sealed-for-life tapered roller bearings never need greasing or maintenance.

**Articulation lock.** It prevents the inadvertent articulation of machine during shipping or while performing service on the machine.

**Parts commonality.** Shares parts commonality with the Cat® 500D-Series Soil Compactors.



## Reliability and Serviceability

*Reliability and serviceability are integrated into every Caterpillar machine. These important features keep your machine investment profitable.*



**Indicators.** Visual indicators allows easy check of radiator coolant, hydraulic oil tank level and air restriction indicator.

**Fiberglass hood.** One-piece fiberglass hood tilts forward for access to the engine and cooling system. Service points are accessible from ground level and are grouped on one side of the engine.

**Operator's station.** The operator's station tilts forward to allow convenient access to the hydraulic pumps.

**Bearings.** Sealed-for-life bearings in the articulation hitch never need to be greased.

**Service interval.** 3 year/3000 hour vibratory bearing lube service interval reduces maintenance.

**Hydraulic test ports.** Quick connect hydraulic test ports simplify system diagnostics.

**Electrical wiring.** The electrical wiring is color-coded and numbered to simplify troubleshooting.

**All-weather connectors.** Nylon braided wrap and all-weather connectors ensure electrical system integrity.

**Caterpillar batteries.** Maintenance-free Caterpillar batteries are mounted in the rear of the machine and are protected by the engine hood. Caterpillar batteries are specifically designed for maximum cranking power and protection against vibration.

**Simple fluid collection.** S•O•S<sup>SM</sup> (Scheduled Oil Sampling) ports allow for simple fluid collection of engine oil, engine coolant and hydraulic oil.

**Hose routing.** Secure hose routing with polyurethane routing blocks to reduce rubbing and increase service life.

**Reman parts.** Factory reman parts are a cost-effective and reliable solution to keep your machines productive. Caterpillar offers a large choice of Reman components including hydraulic pumps and motors.



*The one-piece fiberglass hood tilts for exceptional access to the engine and cooling system. Service points are accessible from ground level and are grouped on one side of the engine.*

## Engine

Four-stroke, four cylinder Caterpillar 3054C diesel engine.

It meets EU Stage II emission requirements. Equipped with a spark arresting muffler.

Ratings at 2200 rpm	kW	hp
Gross power	62	83
Net Power		
EEC 80/1269	59	80
ISO 9249	59	80

Net power advertised is the power available at the flywheel when the engine is equipped with fan, air cleaner, muffler and alternator. All models feature a dual-element, dry-type air cleaner with visual restriction indicator.

### Dimensions

Bore	105 mm
Stroke	127 mm
Displacement	4.4 liters

## Transmission

Two variable displacement piston pumps supply pressurized flow to two dual displacement piston motors. One pump and motor drives the drum propel system while the other pump and motor drives the rear wheels.

The two-pump system ensures equal flow to the drive motors regardless of the operating conditions. In case the drum or wheels lose traction, the other motor can still build additional pressure to provide added torque.

The drive motors have two swashplate positions allowing operation at either maximum torque for compaction and gradeability or maximum speed for moving around the job site. A rocker switch at the operator's console triggers an electric over hydraulic control to change speed ranges.

Speed changes can be made without stopping. A single propel lever located on the control console provides smooth hydrostatic control of the machine's infinitely variable speeds in both forward and reverse.

### Speeds (forward and reverse):

Low range	5.5 km/h
High range	11.5 km/h

Gradeability with or without vibration (subject to underfoot conditions) 44%

## Operator and Machine Protective Equipment

**Backup Alarm** – 112 dB(A) alarm sounds whenever the machine is in reverse. The backup alarm has three sound levels that can be changed with a switch located on the alarm.

**Seat Belt** – 76 mm wide seat belt is standard.

## Sound

**Operator Sound.** The operator sound level measured according to the procedures specified in ISO6394 is 78 dB(A), for cab offered by Caterpillar, when properly installed and maintained and tested with the doors and windows closed.

**Exterior Sound.** The labeled spectator sound power level measured according to the test procedures and conditions specified in 2000/14/EC is 109 dB(A).

## Service Refill Capacities

	Liters
Fuel tank	160
Full fuel capacity	153
Cooling system	18
Crankcase	6.8
Eccentric weight housing	12
Limited slip axle	15.9
Planetary gear reducers	2.3
Hydraulic system	60
Hydraulic filtration system (pressure type)	15 micron absolute

## Final Drives and Axle

Final drive is hydrostatic with gear reducer to the drum and hydrostatic with differential and planetary gear reduction to each wheel.

### Axle:

Heavy-duty fixed rear axle with a limited slip differential for smooth and quiet torque transfer.

Axle width 1.27 m

### Tires:

378 mm x 610 mm (14.9 x 24)  
6-ply flotation

## Steering

A priority-demand hydraulic power-assist steering system provides smooth low-effort steering. The system always receives the power it needs regardless of other hydraulic functions.

### Minimum turning radius:

Inside	3.05 m
Outside	4.73 m

### Steering angle:

(each direction)	37°
------------------	-----

### Oscillation angle:

(each direction)	15°
------------------	-----

### Hydraulic system:

Two 64 mm bore, double-acting cylinders powered by a gear-type pump.

## Brakes

Brake system meets EN 500-1995.

### Service brake features

- Closed-loop hydrostatic drive system provides dynamic braking during operation.

### Secondary brake features\*

- Spring-applied/hydraulically-released multiple disc type brakes mounted on the drum drive gear reducer and within the rear axle. Secondary brakes are activated by a button on the operator's console, loss of hydraulic pressure in the brake circuit or when the engine is shut down. A brake interlock system prevents driving through the secondary brakes.

\* All machines sold within European Union are equipped with a brake release pump which allows the manual release of the secondary brake system for towing the machine.

## Vibratory System

Drum diameter (over drum)	1225 mm
Drum width	1700 mm
Drum shell thickness	25 mm
Eccentric weight drive	Hydrostatic

### Frequency

Standard	31.9 Hz
Optional	23.3-31.9 Hz

### Nominal Amplitude

High	1.67 mm
Low	0.84 mm

### Centrifugal Force at 31.9 Hz

High Amplitude	134 kN
Low Amplitude	67 kN

### Weight at Drum

CS423E*	3410 kg
---------	---------

### Linear Force Static\*\*

CS423E*	20.3 kg/cm
---------	------------

\* With ROPS/FOPS Cab

\*\* Meets NFP 98736 class: VM2

## Instrumentation

Alternator Light, Hour Meter, Fuel Gauge, Horn, Audible Warning Horn for the: Low Engine Oil Pressure Light, High Engine Coolant Temperature Light, High Hydraulic Oil Temperature Light, Low Charge Pressure Light.

## Frame and Drum Yoke

Fabricated from heavy gauge steel plate and rolled sections and joined to the drum yoke at the articulation pivot. Articulation area is structurally reinforced and joined by hardened steel pins. Sealed-for-life hitch bearings never need maintenance.

## Electrical

The 24-volt electrical system consists of two maintenance-free Caterpillar batteries, color-coded and numbered wiring wrapped in nylon braid. The starting system provides 750 cold cranking amps (cca). The system includes a 55-amp alternator.

# Dimensions

All dimensions are approximate.

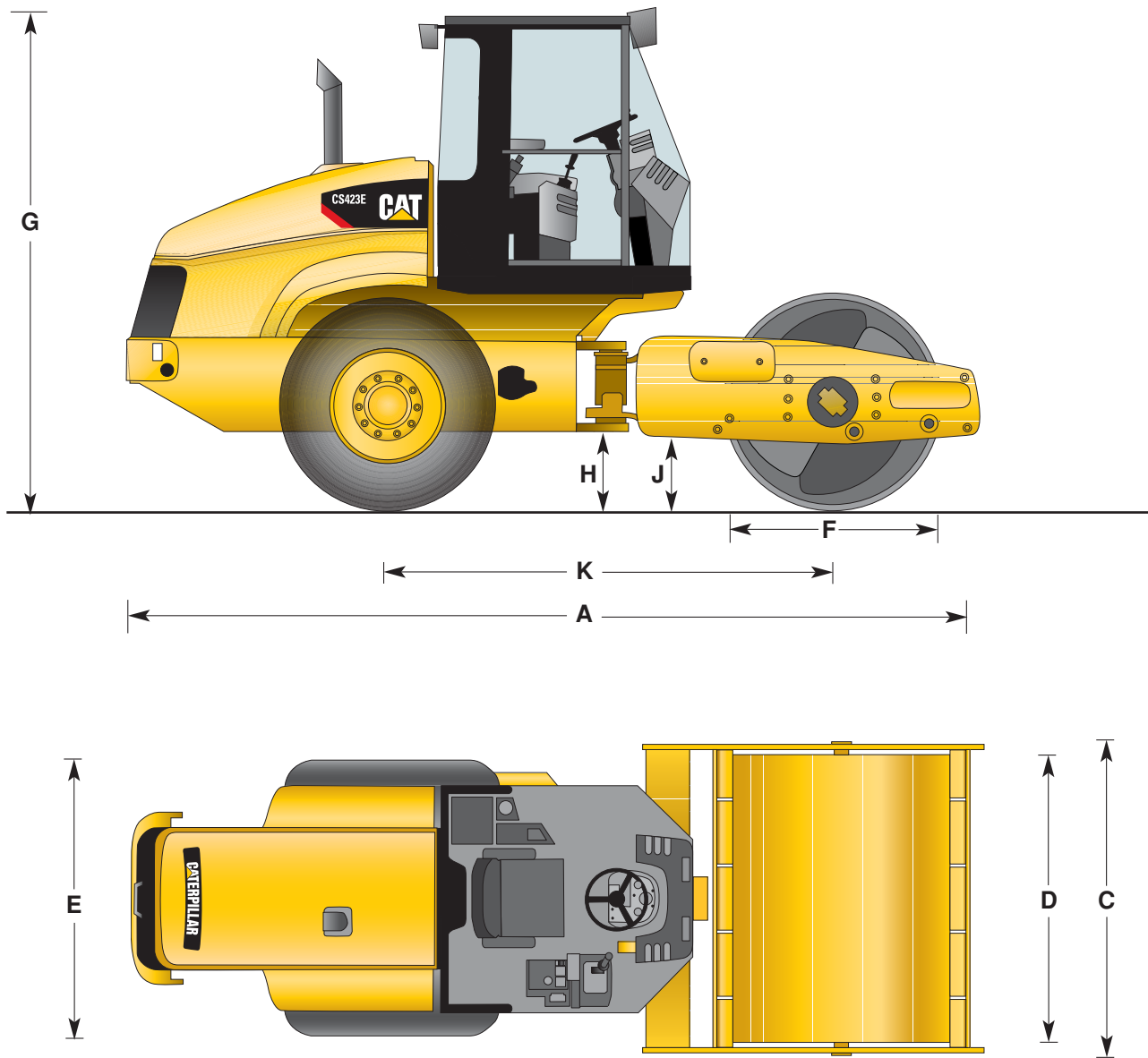

	CS423E		CS423E
<b>A</b> Operating length	4960 mm	<b>F</b> Drum diameter	1221 mm
<b>C</b> Maximum machine width	1800 mm	<b>G</b> Height at ROPS/FOPS Cab	2970 mm
Outside turning radius	4730 mm	<b>H</b> Ground clearance	403 mm
Inside turning radius	3050 mm	<b>J</b> Curb clearance	375 mm
<b>D</b> Compaction width	1676 mm	<b>K</b> Wheelbase	2600 mm
<b>E</b> Width over tires	1650 mm		

---

## Operating Weights

Weights include lubricants, coolant, full fuel and hydraulic tanks and a 80 kg operator. All weights are approximate.

---

### Machine Weights

with open platform	6515 kg
with ROPS/FOPS canopy	6745 kg
with ROPS/FOPS cab	6990 kg

---

### Weight at Drum

with open platform	3360 kg
with ROPS/FOPS canopy	3410 kg
with ROPS/FOPS cab	3510 kg

---

## Total Customer Support System

**Parts availability** – most parts on dealer’s shelf when you need them. Computer-controlled, emergency search system backup.

**Parts stock lists** – dealer helps you plan on-site parts stock to minimize your parts investment while maximizing machine availability.

**Machine management services** – effective preventive maintenance programs, cost-effective repair options, customer meetings, operator and mechanic training.

**Remanufactured parts** – pumps and motors, engines, fuel system and charging system components available from dealer at 20-50% of new part cost.

**Service capability** – dealer’s shop or fast field service by trained technicians using latest tools and technology.

**Literature support** – easy-to-use parts books, operation and maintenance manuals and service manuals to help you get maximum value from Caterpillar equipment.

**Flexible financing** – your dealer can arrange attractive financing on the entire line of Caterpillar equipment. Terms structured to meet cash flow requirements. See how easy it is to own, lease or rent Cat equipment.

# Value Analysis

## Gradeability

- Unique dual pump propel system provides field-proven and industry-leading grade climbing, machine control and tractive power.
- Drum and wheel drive results in excellent tractive effort.
- Separate propel systems outperform flow-dividers.

## Productivity

- Pod-style vibratory system provides high compactive effort and features numerous serviceability advantages to keep the machine productive.
- The Cat 3054C engine is matched to machine weight and application demands.
- High dynamic force helps get density in the fewest number of passes.
- Large pad face area and pad height on the CS423E shell kit option get density deeper in the lift.
- High working speed increases productivity.

## Serviceability

- The one-piece fiberglass hood tilts forward for easy access to daily maintenance points.
- Parts commonality makes servicing easier.
- 3 year/3000 hour vibratory bearing lube service interval keeps maintenance to a minimum and maximizes production.
- Daily check points are accessible from ground level.
- The operator's platform tilts forward for better hydraulic component access.
- The articulation hitch area features sealed-for-life bearings that never need maintenance.

## Versatility

- Standard dual amplitude expands the compactor's application range.
- The large spread between high and low centrifugal force makes it easier to tailor the compactive effort to density specifications.
- The high traction propel system means the machine can go more places.
- The optional padfoot shell kit makes the CS423E an extremely adaptable machine to either cohesive or semi-cohesive material.

## Reliability

- The patented eccentric weight system is completely sealed.
- The absence of swinging counterweights eliminates the chance for metal chips to contaminate the vibratory lubrication system or for heavy weights to wedge together.
- The O-ring face seal hydraulic connections help maintain system integrity.
- The hydraulic hoses are carefully routed and secured by polyurethane mounting blocks to prevent rubbing.
- The Cat electrical system includes two Caterpillar batteries and color-coded and numbered wires protected by vinyl-coated nylon braid wrap.

## Optional Equipment

Some options listed may be an option in some areas and standard in others. Consult your dealer for specifics.

**Roll Over Protective Structure/Falling Object Protective Structure (ROPS/FOPS) canopy** is a two-post structure that bolts directly onto flanges welded to the operator platform. Includes two front-facing and two rear-facing working lights, handrails and a rear view mirror. The structure meets ISO 3449-1992 and ISO 3471-1994.

**ROPS/FOPS Cab** includes a cloth suspension seat, one access door, tinted safety glass windows, electric wipers front and rear, heater/defroster, two vertically sliding side windows for ventilation, two exterior rear view mirrors, two front-facing and two rear-facing working lights, interior dome light, coat hook. Cab can be ordered with or without air conditioning. Cab is fully EROPS rated and meets ISO 3449-1992 and ISO 3471-1994.

**Sun Visor** for the front windshield can be installed on machines equipped with a ROPS/FOPS cab.

**Roll-Down Sun Screen** for the rear window can be installed on machines equipped with a ROPS/FOPS cab.

**Operator Platform Lift Cylinder** is available and provides a hydraulic cylinder to raise and lower the operator's platform or cab.

**Variable Frequency** is an electronic displacement control on the vibratory pump that is operated by a dial on the operator's station. Engine rpm remains constant. Frequency range from 23.3-31.9 Hz makes it easier to match frequency, amplitude and working speed to job conditions. Includes the vibratory gauge.

**Vibratory Gauge** is mounted on the console in front of the operator and displays the actual vibratory system frequency. (Standard with the variable frequency option.)

**Rotating Beacon** includes an amber beacon and mount that can be attached to machines with ROPS/FOPS canopy or ROPS/FOPS cab.

**Two-Piece Padfoot Shell Kit** bolts onto the smooth drum of CS423E. Features 90 mm high pads. Each shell half weights 453 kg and includes a special bumper for a quick conversion.

**Polyurethane Drum Scrapers** for the CS423E provide a front and rear scraper for continuous contact with the drum surface and replaces the standard steel front scraper.

**Spare Tire with Rim** is available for both the flotation tread and the traction tread.

**Recording Module** provides a visual gauge for reading worktime, machine speed, distance covered and amplitude selection.

**Traction Tires** improve traction when CS423E is equipped with Padfoot Shell Kit.

**Compaction Indicator CI 010** includes LED panel indicating compaction level with integrated LCD screen displaying travel speed and compaction meter value. Also Includes hand-held printer.

**Compactometer ALFA 022R** includes compaction meter value dial, frequency meter dial and resonance meter value dial.

# CS423E Vibratory Soil Compactor

For more complete information on Cat products, dealer services, and industry solutions, visit us on the web at [www.cat.com](http://www.cat.com)

Materials and specifications are subject to change without notice. Featured machines in photos may include additional equipment. See your Caterpillar dealer for available options.

© 2007 Caterpillar -- All rights reserved

HEHG2823-2 (02/2007) hr

CAT, CATERPILLAR, their respective logos, "Caterpillar Yellow" and the POWER EDGE trade dress as well as corporate and product identity used herein, are trademarks of Caterpillar and may not be used without permission.

**CATERPILLAR**<sup>®</sup>