

232B Series 2

Skid Steer Loader



Features

The Cat® 232B Series 2 Skid Steer Loader, with its vertical lift design, delivers extended reach and lift height for quick and easy truck loading. Its stability and lifting performance provides excellent material handling.

The 232B Series 2 features the following:

Ergonomic Operator Station. Easy to use pilot operated joystick controls for reduced operator fatigue and increased productivity.

High Performance Power Train. Provides high engine horsepower and torque, allowing part-throttle operation for lower sound levels and fuel consumption.

Advanced Hydraulic System. Designed for maximum power and reliability.

Serviceability. Easy routine maintenance helps reduce machine downtime for greater productivity.

Work Tools. Caterpillar's broad range of performance matched work tools make the Cat Skid Steer Loader the most versatile machine on the jobsite.

232B Series 2 Specifications

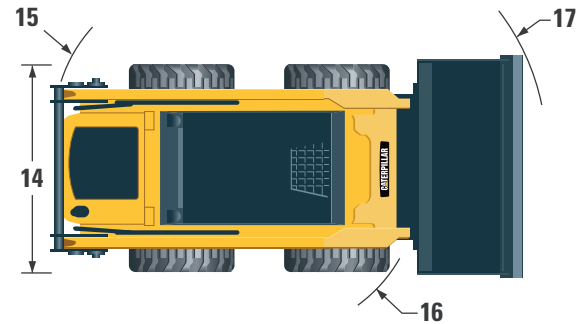
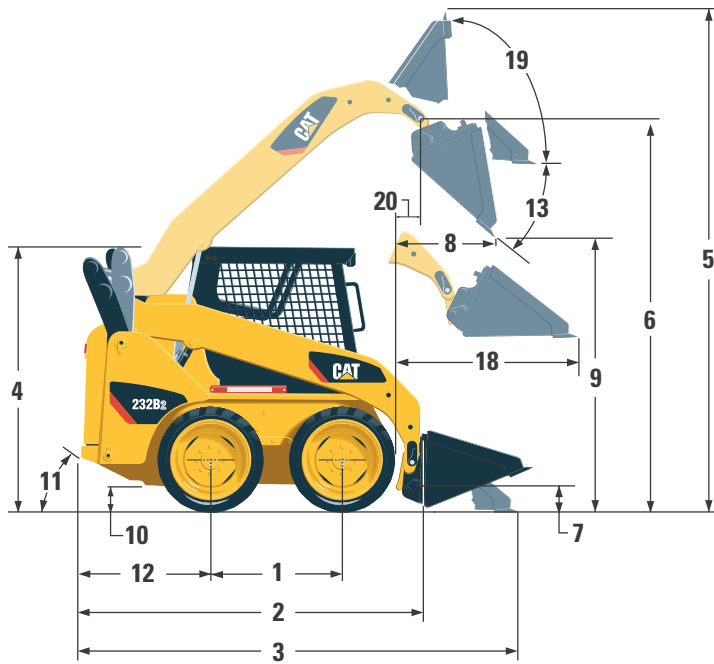

Dimensions

	mm
1 Wheelbase	1094
2 Length without Bucket	2760
3 Length with Bucket on Ground	3437
4 Height to Top of Cab	1953
5 Max. Overall Height	3894
6 Bucket Pin Height at Max. Lift	3013
7 Bucket Pin Height at Carry Position	247
8 Reach at Max. Lift and Dump	766
9 Clearance at Max. Lift and Dump	2243
10 Ground Clearance	145
11 Departure Angle	28°
12 Bumper Overhang Behind Rear Axle	989
13 Maximum Dump Angle	50°
14 Vehicle Width over Tires	1524
15 Turning Radius from Center – Machine Rear	1545
16 Turning Radius from Center – Coupler	1409
17 Turning Radius from Center – Bucket	2221
18 Max. Reach with Arms Parallel to Ground	1231
19 Rack Back Angle at Max. Height	87°
20 Bucket Pint Reach at Max. Lift	285

Engine

Horsepower (hp) are metric

Engine Model	Cat® C2.2 T
Gross Power SAE J1995	46 kW/63 hp
Net Power ISO 9249 at 2600 rpm	42 kW/57 hp
Displacement	2.2 L
Stroke	100 mm
Bore	84 mm

Weight

Operating Weight	3056 kg
------------------	---------

Power Train

Max. Travel Speed (Forward or Reverse)	10 km/h
--	---------

Hydraulic System

Hydraulic Flow – Standard	
Loader Hydraulic Pressure	230 bar
Loader Hydraulic Flow	60 L/min
Hydraulic Power	23 kW/31 hp

Operating Specifications

Rated Operating Capacity	862 kg
with Optional Counterweight	883 kg
Tipping Load	1858 kg
Breakout Force	18 kN

Cab

ROPS	ISO 3471:1994
FOPS	ISO 3449 APR98 Level I, ISO 3449:1992 Level I ISO 3449:1992 Level II

Service Refill Capacities

	Liter
Chain Box, each side	6
Cooling System	10
Engine Crankcase	10
Fuel Tank	58
Hydraulic System	55
Hydraulic Tank	35

232B Series 2 Skid Steer Loader

Work Tools

- Augers
- Angle Blades
- Brooms
- Cold Planers
- Forks & Carriages
- Grapple Buckets & Forks
- Landscape Rakes
- Landscape Tillers
- Material Handling Arms
- Stump Grinders
- Trenchers
- Snow Blowers
- Vibratory Compactors
- Wheel Saws
- Dozer Blades

Standard Equipment

Electrical

- Electrical System, 12 V
- Alternator, 85 A
- Ignition Key Start/Stop Switch
- Lights: *Gauge Backlighting, Two Rear Tail Lights, Two Adjustable Front Halogen Lights, Dome Light*

Operator Environment

- Gauges: *Fuel Level, Hour Meter*
- Operator Warning System Indicators: *Air Filter Restriction, Alternator Output, Armrest Raised/Operator Out of Seat, Engine Coolant Temperature, Engine Oil Pressure, Glow Plug Activation, Hydraulic Filter Restriction, Hydraulic Oil Temperature, Parking Brake Engaged*
- Vinyl Seat
- Pull Down Ergonomic Contoured Armrest
- Control Interlock System, when operator leaves seat or armrest raised: *Hydraulic System Disables, Hydrostatic Transmission Disables, Parking Brake Engages*
- ROPS Cab, Open, Tilt Up
- FOPS, Level I
- Top and Rear Windows
- Headliner, Deluxe
- Floor Mat
- Interior Rear View Mirror
- 12 volt Electric Socket
- Horn

Power Train

- Cat® C2.2 T Stage IIIA Compliant Diesel Engine
- Air Cleaner, Dual Element, Radial Seal
- S-O-SSM Sampling Valves, Engine Oil and Hydraulic Oil

Mandatory Equipment

- Quick Coupler, Mechanical or Hydraulic
- Seat Belt, 50 mm or 75 mm
- EU Preparation Package

Comfort Package (select one of the following):

- Open ROPS (C0): *Static Seat*
- Open ROPS (C1): *Suspension Seat, Cup Holder*
- Enclosed ROPS (C2): *C1 and Heater, Cab Door, Side Windows, Cab Debris Barrier*
- Enclosed ROPS (C3): *C2 and Air Conditioner*

Control Package (select one of the following):

- Control Package 1: *On/Off Auxiliary Hydraulics Basic*
- Control Package 2: *Proportional Auxiliary Hydraulics Deluxe*

- Filters, Spin on, Hydraulic
- Filters, Bayonet-type, Fuel and Water Separator
- Tilt Up Radiator/Hydraulic Oil Cooler
- Muffler, Standard
- Spring Applied, Hydraulically Released, Wet Multi Disc Parking Brakes
- Hydrostatic Transmission
- Four Wheel Chain Drive

Other

- Engine Enclosure, Lockable
- Extended Life Antifreeze, -36°C
- Machine Tie Down Points (4)
- Support, Lift Arm
- Hydraulic Oil Level Sight Gauge
- Radiator Coolant Level Sight Gauge
- Radiator, Expansion Bottle
- Caterpillar XT™ ToughGuard™ Hose
- Auxiliary, Hydraulics, Continuous Flow
- Heavy Duty, Flat Faced Quick Disconnects
- Split D-Ring to Route Work Tool Hoses Along Side of Left Lift Arm
- Electrical Outlet, Beacon
- Belly Pan Cleanout

Optional Attachments

- Counterweight, increases rated operating capacity 45 kg
- Beacon, Rotating
- Engine Block Heater – 120 V or 240 V
- Oil, Hydraulic, Cold Operation
- Paint, Custom
- Backup Alarm
- Heavy Duty Battery, 850 CCA

232B Series 2 Skid Steer Loader

For more complete information on Cat products, dealer services, and industry solutions, visit us on the web at www.cat.com

HEHL3638-1 (06/2008) hr

© 2007 Caterpillar -- All Rights Reserved

Materials and specifications are subject to change without notice. Featured machines in photos may include additional equipment. See your Caterpillar dealer for available options.

CAT, CATERPILLAR, their respective logos, "Caterpillar Yellow" and the POWER EDGE™ trade dress, as well as corporate and product identity used herein, are trademarks of Caterpillar and may not be used without permission.

CATERPILLAR®
TODAY'S WORK. TOMORROW'S WORLD.™