

928Hz

Wheel Loader

CATERPILLAR®



Cat® C6.6 Engine with ACERT™ Technology

Net power (SAE J1249) 111 kW 149 hp
EPA Tier 3, EU Stage III Compliant

Weight

Operating Weight 12 564 kg 27,699 lb

Buckets

Bucket Capacity 2.0-2.3 m³ 2.6-3.0 yd³

928Hz Features

High Performance Power Train

Clean, quiet operation with superior power.

Powerful Hydraulic System

System senses work demand and adjusts flow and pressure to match for precise, efficient control.

Loader Linkage

Proven design delivers outstanding bucket loading performance.

Comfortable Cab

Large, spacious cab and low-effort, ergonomic joystick controls let you concentrate on your work.

Buckets

Caterpillar® buckets deliver superior digging, loading and carrying performance.



Contents

Power Train	3
Hydraulic System	4
Loader Linkage	4
Operator Station	5
Buckets.....	6
Serviceability.....	7
Customer Support.....	7
Specifications	8
Standard and Optional Equipment.....	14

The Cat® 928Hz Wheel Loader leads the industry in operator comfort and performance. Size, power, and performance make this machine ideal for a wide range of jobs. Fast cycle times help you move more material. Large spacious cab with joystick control keeps you comfortable throughout the work day, allowing you to get more done. Loader design delivers strength and durability with superior control. Discover how much more you can get done with the new 928Hz.



Power Train

Delivers maximum rimpull to the ground and full power to loader hydraulics.

Cat Engine

The Cat® C6.6 engine provides cleaner, quieter operation while delivering superior performance and durability. The 111 kW (149 hp) rated net power engine meets all worldwide emissions standards and features flatter power curve for outstanding response in the working RPM range (1,900 to 2,300), noise reduction technologies for up to 5 dB reduction, and patented ACERT™ Technology combined with common rail fuel system, smart waste gate turbocharger and crossflow head design for reduced emissions.

Cat Axles

Heavy-duty axles feature hardened gears and bearings for durable performance. Rear axle oscillates up to 12 degrees to help assure four-wheel ground contact for optimum traction and stability. Optional front and rear Limited Slip Differentials enable outstanding traction in poor underfoot conditions.

Cat Transmission

Rugged Cat transmission uses heavy-duty components for durable and reliable operation. The operator can choose between manual shift and two autoshift modes, Performance or Economy. Performance mode provides maximum acceleration while the economy mode increases fuel economy and improves operator comfort.

Hydraulics

System provides high efficiency with low effort, precise control.



Proven Design

Time tested hydraulic system provides low effort operation and superior control. Fast loader cycle times help you get more done.

Dual Hydraulic Pumps System

Load-sensing steering pump provides outstanding response during heavy and light duty operations.

High output implement pump provides all the hydraulic power required to move loads at all engine speeds.

Ride Control System

The optional Ride Control System provides a comfortable ride and excellent material retention.

Nitrogen charged accumulator enables optimum cushioning over uneven terrain for all loads and speeds.

The system operates in Automatic – as the loader ground speed exceeds 5 km/h (3 mph) the system will activate, below 5 km/h (3 mph) the system is off providing maximum lift power.

Loader Linkage

Strong design delivers superior performance.

Z-Bar Design

Z-bar linkage generates excellent breakout force and good rack back angle for better bucket loading and load retention.

Lift arms are solid steel, providing superior strength with an excellent front end viewing area. The proven design offers excellent dump clearance and reach for exceptional truck loading performance.





Operator Station

Superior comfort keeps you productive, all day long.

Experience comfort and convenience in the H-Series cab. The spacious interior and ergonomic controls keep you comfortable throughout the work day. Choose the seat that meets your needs – the standard, fully adjustable seat or the optional Cat Contour seat for added adjustment and air suspension. The two-door design lets you enter and exit from either side of the machine and wide, serrated steps provide stable footing. Both doors lock open 180 degrees and feature sliding glass windows for better communication with workers on the ground. Large flat glass windows provide excellent visibility all around the machine. The rear window features a standard electric defroster.

Controls

Low effort, ergonomic joystick controls provide easy operation of lift and tilt functions. The standard joystick features an integrated directional control switch for added convenience. The operator programmable transmission neutralizer can be set in seconds optimizing brake effort for all applications.

Instrument Panel

The sealed instrument panel with easy to read white faced gauges and indicators keeps the operator informed of system conditions. The large LED readout provides ground speed and other critical information.

Optional Rear View Camera

This work area visual enhancement system uses a closed circuit video monitoring system. Up to three cameras can be mounted on the machine frame. Objects can be viewed on a color LCD monitor in the cab.

Buckets

Cat[®] Buckets are built for high performance.

The Right Bucket for the Job

Caterpillar offers a variety of buckets to meet your specific job requirements. Careful match of the bucket design and machine operating characteristics provide the best digging, loading and carrying performance.

General Purpose Buckets

Caterpillar general purpose buckets, available in 2.0 m³ (2.6 yd³) and 2.3 m³ (3.0 yd³) capacities with bolt-on cutting edge, are suitable for most general applications. Features include:

- Improved bucket design with longer floor and a larger radius for easier flow of material into the bucket.
- Patented Two-Bolt Corner Guard Cutting Edge System for superior wear resistance, better stability and a simple bolt-on system.
- Built-in, replaceable heel wear plates for extended bucket life.

Sand and Gravel Bucket

This 2.5 m³ (3.5 yd³) heavy duty material handling bucket, built with additional wear plates on the floor and sides, is engineered for ready mix or batch plant applications with plant capacity of 200 tons per hour.

Ground Engaging Tools

Ground engaging tools include hardened steel cutting edges, choice of short or long teeth and a variety of tooth adapters. These tools optimize performance, improve load retention and extend the useful life of Caterpillar buckets.

Versatility

For expanded machine versatility, factory installed quick couplers and other special purpose buckets are also available. Contact your Caterpillar dealer for details.



Serviceability

Easy access and minimal maintenance requirements keep your machine on the job.



Convenient service features make maintenance easy.

All service points are accessible from ground level on the right side of the engine. Gull-wing doors with gas struts lift for exceptional access to filters and service points. Extended service intervals reduce service time and increase machine availability.

- Sight gauges let you easily check radiator coolant, hydraulic oil and transmission oil levels as well as engine air filter restriction without opening the air cleaner.
- Standard pressure taps allow quick diagnosis of the entire hydraulic system.
- S•O•SSM ports make oil sampling quicker, cleaner and provide the best oil sample for analysis.
- Spin-on filters for engine oil, transmission oil and hydraulic oil are vertically mounted for easier servicing.
- 928Hz features a standard electronic fuel prime pump.
- Sequentially placed radiator and oil coolers are easy to access.
- Swing-out cooling fan allows quick and easy cleaning and servicing of the radiator. The fan is hydraulically driven and separate from the engine compartment for low noise operation.
- Optional reversing fan cleans screens without interrupting machine operation.

Customer Support

Unmatched support makes the difference

Your Cat dealer is ready to assist you with your purchase decision and everything after.

- Make comparisons of machines, with estimates of component life, preventative maintenance and cost of production.
- Financing packages are flexible to meet your needs.
- Your Cat dealer can evaluate the cost to repair, rebuild and replace your machine, so you can make the right choice.
- For more information on Cat products, dealer services and industry solutions, visit us at www.cat.com.



928Hz Wheel Loader Specifications

Engine		
Rated net power @ 2,300 rpm	111 kW	149 hp
Model	Cat® C6.6	
SAE J1349	111 kW	149 hp
ISO 9249 (1997)	112 kW	150 hp
EEC 80/1269	112 kW	150 hp
Max. net power @ 2,000 rpm	119 kW	160 hp
SAE J1349	119 kW	160 hp
ISO 9249 (1997)	120 kW	161 hp
EEC 80/1269	120 kW	161 hp
Bore	105 mm	4.13 in
Stroke	127 mm	5 in
Displacement	6.6 L	403 in ³
Net torque	727 N·m	536 ft-lb
Peak torque	742 N·m	547 ft-lb

- Net Power ratings are tested at the reference conditions for the specified standard.
- Net power shown is the power available at the flywheel when the engine is equipped with alternator, air cleaner, muffler and fan at minimum speed.
- No derating required up to 3000 m (9,843 ft) altitude. Auto derate protects hydraulic and transmission systems.
- When the fan is at maximum speed, Rated Net Power is 97 kW (130 hp) and Maximum Net Power is 106 kW (142 hp) at the flywheel per the SAE reference conditions.
- The Caterpillar® C6.6 engine meets Tier 3 off-highway emission regulations.

Engine Torque

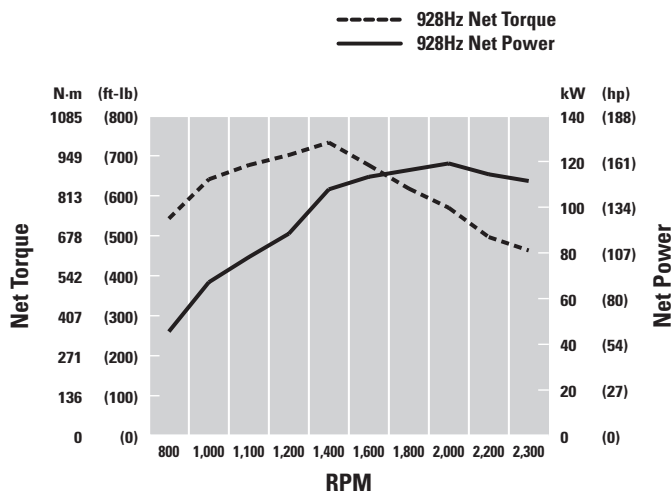

Buckets		
Bucket capacities	2.0 m ³ - 2.3 m ³	2.6 yd ³ - 3.0 yd ³

Weights		
Operating weight	12 564 kg	27,699 lb
• Specifications shown are for 928Hz with optional counterweight, standard lubricants, full fuel tank, deluxe cab, Limited Slip rear axle with heavy duty brakes, additional guarding, 2.0 m ³ (2.6 yd ³) bucket with bolt-on cutting edge, 80 kg (176 lb) operator and 20.5 R25 radial (L-3) XHA tires.		

Steering		
Steering articulation	40°	40°
Minimum turning radius (over tire)	5233 mm	206 in
Steering angle, each direction	40°	40°
Steering cylinders, two, bore	70 mm	2.75 in
Hydraulic output at 2,300 engine rpm and 6900 kPa (1,000 psi)	104 L/min	27 gal/min
Maximum working pressure	20 700 kPa	3,000 psi

Loader Hydraulic System		
Output at 2,300 engine rpm and 6900 kPa (1,000 psi) with SAE 10W oil at 65° C (150° F)	151.5 L/min	40.3 gal/min
Hydraulic cycle time	10.1 Seconds	
Pump flow – implement pump	152 L/min	40.2 gal/min
Relief pressure – implement pump	258.9 bar	3,755 psi
Maximum working pressure	25 900 kPa	3,755 psi
Hydraulic cycle time	10.1 Seconds	
Raise	6.1 Seconds	
Dump	1.2 Seconds	
Lower, empty, float down	2.8 Seconds	
Total	10.1 Seconds	
Lift cylinders, double acting:		
Bore	120.6 mm	4.75 in
Stroke	685 mm	27 in
Tilt cylinder, double acting:		
Bore	127 mm	5 in
Stroke	550 mm	21.7 in

Service Refill Capacities		
Fuel tank	225 L	59.4 gal
Cooling system	42 L	11.1 gal
Crankcase	15 L	4.0 gal
Transmission	34.5 L	9.1 gal
Differentials and final drives:		
Front	26 L	6.9 gal
Rear	25 L	6.6 gal
Hydraulic system (including tank)	125 L	33 gal
Hydraulic tank	70 L	18.5 gal

Transmission

Standard transmission		37.7 km/h	23.4 mph
max travel speeds			
Forward	1	7.9 km/h	4.9 mph
	2	12.6 km/h	7.8 mph
	3	25.8 km/h	16 mph
	4	37.7 km/h	23.4 mph
Reverse	1	7.9 km/h	4.9 mph
	2	12.6 km/h	7.8 mph
	3	25.8 km/h	16 mph

Tires

Size	20.5 R25 L3 XHA	
Tread width	2570 mm	8 ft 5 in

- Choice of:
 - 17.5-25, 12PR (L-2)
 - 17.5-25, 12PR (L-3)
 - 17.5 R25, radial (L-2)
 - 17.5 R25, radial (L-3)
 - 20.5-25, 12PR (L-2)
 - 20.5-25, 12PR (L-3)
 - 20.5 R25, radial (L-2/L-3)
 - 600/65 R25, radial (L-3)
- Other tire choices are available, contact your Cat® Dealer for details.
- In certain applications, the loader's productive capabilities may exceed the tire's tonnes-km/h (ton-mph) capabilities. Caterpillar recommends that you consult a tire supplier to evaluate all conditions before selecting a tire model.

Cab

ROPS	SAE J1040 MAY94, ISO 3471-1994
FOPS	SAE J/ISO 3449 APR98 Level II, ISO 3449 1992 Level II

- Caterpillar cab and Rollover Protective Structure (ROPS) are standard in North America and Europe.
- When properly installed and maintained, the cab offered by Caterpillar, when tested with doors and windows closed as per work cycle procedures specified in ANSI/SAE J1166 May 90, results in operator sound exposure Leq (equivalent sound pressure level) of 74 dB(A).

Operating Specifications

Static tipping load (full turn)	8658 kg	19,089 lb
Reach – full lift/45 degree dump angle	927 mm	3 ft 0 in
Dump clearance – full lift/45 degree dump angle	2879 mm	9 ft 6 in
Articulation angle	40°	40°

928Hz Wheel Loader Specifications

Dimensions

All dimensions are approximate. Dimensions may vary with bucket. Refer to Operating Specifications.

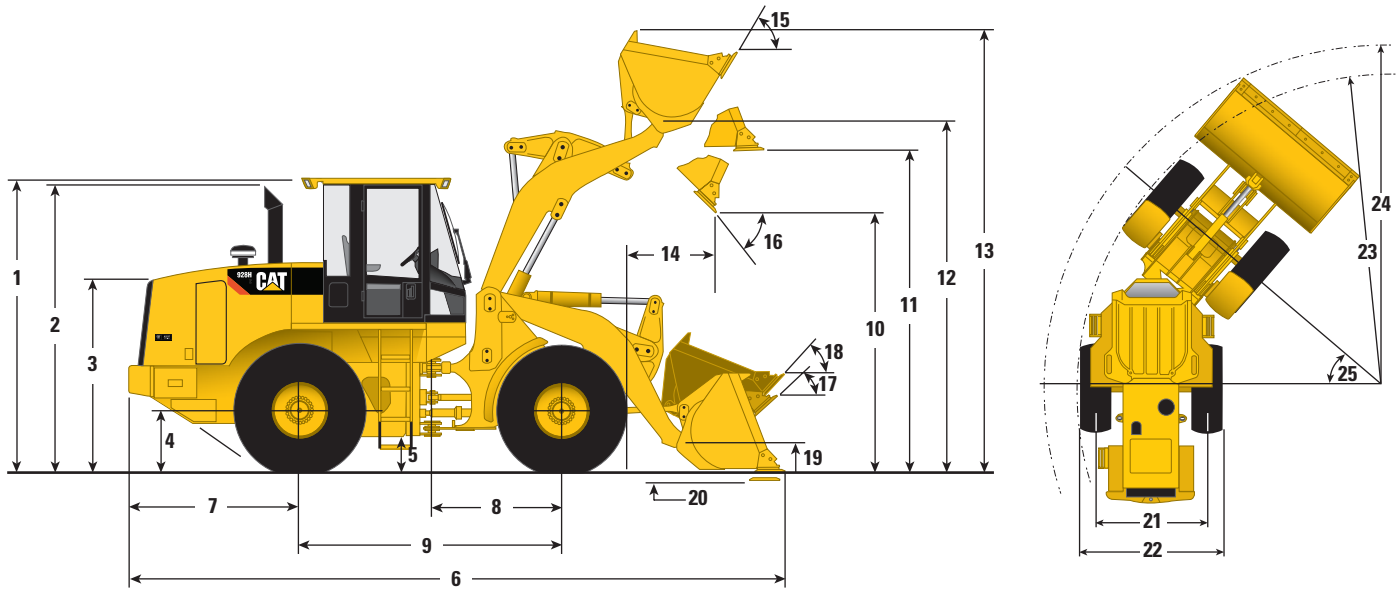

1	Height to top of ROPS/FOPS	3269 mm	(10 ft 9 in)
2	Height to top of exhaust stack	3189 mm	(10 ft 6 in)
3	Height to top of hood	2197 mm	(7 ft 2 in)
4	Height to center of axle	685 mm	(2 ft 3 in)
5	Ground clearance	408 mm	(1 ft 4 in)
6	Overall length	7252 mm	(23 ft 10 in)
7	Length – rear axle to bumper	1920 mm	(6 ft 4 in)
8	Center line of front axle to hitch	1450 mm	(4 ft 9 in)
9	Wheel base length	2900 mm	(9 ft 6 in)
10	Dump clearance at maximum lift and 45° dump	2879 mm	(9 ft 5 in)
11	Bucket clearance at maximum lift and level	3752 mm	(12 ft 4 in)
12	Bucket pin height at maximum lift	3872 mm	(12 ft 8 in)
13	Overall height – bucket raised	4971 mm	(16 ft 4 in)
14	Reach at maximum lift and 45° dump	927 mm	(3 ft 0 in)
15	Rack back angle at maximum lift		60°
16	Dump angle at maximum lift		45°
17	Rack back angle at ground		44°
18	Rack back angle at carry		47.8°
19	Carry height	449 mm	(1 ft 6 in)
20	Digging depth	86 mm	(3 in)

Dimensions listed are for 928Hz with 2.0 m³ (2.6 yd³) pin-on bucket with bolt-on cutting edge, cab with A/C, optional counterweights, limited slip axles, heavy duty rear brakes, additional guarding, sound suppression, work tool, 80 kg (176 lb) operator and Michelin 20.5R25 L3 XHA tires.

	20.5 R25 (L-3) Tires		17.5-25 12PR (L-2) Tires	
21	Width at tread center	1950 mm (6 ft 5 in)	1950 mm (6 ft 5 in)	
22	Overall width over tires	2570 mm (8 ft 5 in)	2407 mm (7 ft 11 in)	
23	Minimum turning radius over tires	5275 mm (17 ft 4 in)	5186 mm (17 ft 0 in)	
24	Minimum turning radius over bucket at ground level	5794 mm (19 ft 0 in)	5795 mm (19 ft 0 in)	
25	Steering angle – left/right	40°	40°	
	Change in vertical dimension	no change	no change	-65 mm (-2.6 in)

Operating Specifications

		Pin-on Buckets					
		With Bolt-On Cutting Edge		With Bolt-On Teeth & Segments*		With Bolt-On Teeth*	
Rated bucket capacity (§)	m ³	2.0	2.3	2.0	2.3	1.9	2.2
	yd ³	2.6	3.0	2.6	3.0	2.5	2.9
Struck capacity (§)	m ³	1.7	1.9	1.7	1.9	1.6	1.8
	yd ³	2.2	2.5	2.2	2.5	2.1	2.4
Bucket width	mm	2549	2549	2549	2549	2549	2549
	ft/in	8'4"	8'4"	8'4"	8'4"	8'4"	8'4"
10 Dump clearance at full lift and 45° discharge (§)	mm	2879	2842	2766	2730	2766	2729
	ft/in	9'5"	9'4"	9'1"	8'11"	9'1"	8'11"
14 Reach at full lift and 45° discharge (§)	mm	927	964	1021	1058	1021	1058
	ft/in	3'0"	3'2"	3'4"	3'6"	3'4"	3'6"
Reach at 45° discharge and 2130 mm (7'0") clearance (§)	mm	1455	1474	1492	1509	1492	1509
	ft/in	4'9"	4'10"	4'11"	4'11"	4'11"	4'11"
Reach with lift arms horizontal and bucket level	mm	2253	2305	2399	2451	2399	2451
	ft/in	7'5"	7'7"	7'10"	8'0"	7'10"	8'0"
20 Digging depth (§)	mm	86	86	99	99	99	99
	in	3.4"	3.4"	3.9"	3.9"	3.9"	3.9"
6 Overall length	mm	7252	7304	7398	7450	7378	7430
	ft/in	23'10"	24'0"	24'3"	24'5"	24'2"	24'5"
13 Overall height with bucket at full raise (§)	mm	4971	5070	4971	5070	4971	5070
	ft/in	16'4"	16'8"	16'4"	16'8"	16'4"	16'8"
24 Loader clearance radius with bucket in carry position (§)	mm	5781	5796	5845	5860	5845	5860
	ft/in	19'0"	19'0"	19'2"	19'3"	19'2"	19'3"
Static tipping load straight (§)	kg	9983	9911	9819	9746	9923	9851
	lb	22,008	21,850	21,647	21,486	21,876	21,717
Static tipping load full 40° turn (§)	kg	8654	8585	8490	8420	8594	8525
	lb	19,079	18,928	18,718	18,564	18,948	18,795
Breakout force (§)	kg	11 723	11 095	11 590	10 961	12 604	11 880
	lb	25,844	24,460	25,552	24,165	27,787	26,191
Operating weight	kg	12 564	12 618	12 669	12 753	12 614	12 668
	lb	27,699	27,818	27,997	28,116	27,809	27,928

Specifications shown are for 928Hz with cab with A/C, optional counterweight, limited slip axles, heavy duty rear brakes, additional guarding, sound suppression, work tool, 80 kg (176 lb) operator and Michelin 20.5 R25 L3 XHA tires.

* Dimensions are measured to the tip of the bucket teeth to provide accurate clearance data. SAE standards specifies the cutting edge.

(§) Specifications and ratings conform to all applicable standards recommended by the Society of Automotive Engineers (SAE), including SAE-Standards J732 JUN92 and J742 FEB85 governing ratings.

Other Ground Engaging Tools available, consult your Cat dealer.

928Hz Wheel Loader Specifications

Typical Material Densities – Loose

	kg/m ³	lb/yd ³		kg/m ³	lb/yd ³
Basalt	1960	3,305	Gypsum		
Bauxite, Kaolin	1420	2,394	broken	1810	3,052
Clay			crushed	1600	2,698
natural bed	1660	2,799	Limestone		
dry	1480	2,495	broken	1540	2,596
wet	1660	2,799	crushed	1540	2,596
Clay and gravel			Sand		
dry	1420	2,394	dry, loose	1420	2,394
wet	1540	2,596	damp	1690	2,849
Decomposed rock			wet	1840	3,102
75% rock, 25% earth	1960	3,305	Sand and clay		
50% rock, 50% earth	1720	2,900	loose	1600	2,698
25% rock, 75% earth	1570	2,647	Sand and gravel		
Earth			dry	1720	2,900
dry, packed	1510	2,546	wet	2020	3,416
wet, excavated	1600	2,698	Sandstone	1510	2,546
Granite			Shale	1250	2,107
broken	1660	2,799	Slag		
Gravel			broken	1750	2,950
pitrun	1930	3,254	Stone		
dry	1510	2,546	crushed	1600	2,698
dry, 6-50 mm (0.2-2")	1690	2,849			
wet, 6-50 mm (0.2-2")	2020	3,406			

Bucket Selection – Pin-on Buckets

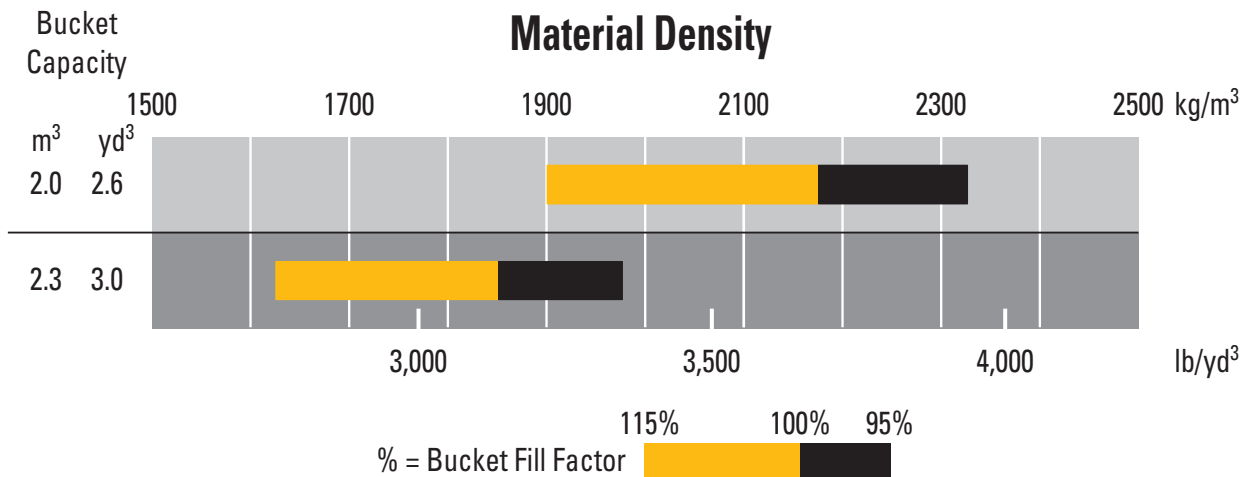

Supplemental Specifications

	Change in Operating Weight		Change in Articulated Static Tipping Load with Pin-On Bucket 2.0 m ³ (2.6 yd ³)	
	kg	lb	kg	lb
Canopy, ROPS (less cab)	-198	-436	-181	-398
No optional counterweights	-470	-1,034	-751	-1,652
Substitute 296 kg (653 lb) optional counterweight	-174	-383	-278	-612
Without guard, crankcase	-17	-37	-22	-48
Without guard, power train	-58	-128	-56	-123
Without ride control system	-41	-90	-28	-62
Without secondary steering	-42	-92	-52	-114
Tires, 1-piece rims				
17.5-25, 12PR (L-2)	-661	-1,454	-410	-902
17.5-25, 12PR (L-3)	-582	-1,280	-361	-794
17.5-25, radial (L-2/L-3)	-519	-1,142	-322	-708
17.5-25, radial (L-2)	-614	-1,351	-381	-838
17.5-25, radial (L-3)	-458	-1,008	-284	-625
Tires, 3-piece rims				
17.5-25, 12PR (L-2)	-529	-1,164	-328	-722
17.5-25, 12PR (L-3)	-457	-1,005	-283	-623
17.5-25, radial (L-2/L-3)	-413	-909	-256	-563
17.5-R25, radial (L-2)	-489	-1,076	-303	-667
17.5-R25, radial (L-3)	-389	-856	-241	-530
20.5-25, 12PR (L-2)	-240	-528	-149	-328
20.5-25, 12PR (L-3)	-96	-211	-60	-132
20.5-25, radial (L-2/L-3)	-52	-114	-33	-73
20.5 R25, radial (L-2)	-172	-378	-107	-235
20.5 R25, radial (L-3)	0	0	0	0
600/65 R25, radial (L-3) Michelin	+4	+9	+2	+4

928Hz Standard Equipment

Standard equipment may vary. Consult your Caterpillar dealer for details.

ELECTRICAL

Alternator, 95-amp brushless
Alarm, back-up
Batteries, maintenance-free, 950 CCA, (2)
Directional signals (front & rear)
Starting and charging system, 24V
Halogen work lights (front & rear)
Ignition key start/stop switch
Roading lights
Starting aid, thermal
Switch, battery disconnect

OPERATOR ENVIRONMENT

Standard two door cab includes all of the following items:

Air conditioner, heater/defroster
Sliding glass door windows
Radio ready
12 volt electrical accessory outlet
Sealed Instrument Gauge:
• Engine RPM
• Hydraulic oil temperature
• Engine coolant temperature
• Torque converter oil temperature
• Fuel level
• Digital LED speedometer, hour meter/odometer
Indicator Lights:
• Turn signal
• Primary steering malfunction
• Hydraulic oil bypass
• Parking brake applied
• Brake charge pressure low
• Transmission oil temperature
• General warning
• Electrical system voltage low
• Fuel water separator
• Engine oil temperature
• Bright lights activated
Adjustable tilt steering column
Coat hook
Ground level door release

Horn, steering wheel mounted (electric)
Hydraulic control lever lockout
Interior light
Lighter
Lunch box storage with cup holder
Pilot hydraulic implement controls
Rear window defroster, electric
Rear view mirrors (2 inside)
Seat, adjustable suspension, armrest (fabric or vinyl)
Seat belt, 75 mm (3 in), retractable
Tinted safety glass, front
Tool box
Wet arm wiper/washer (front & rear), front intermittent

POWER TRAIN

Engine, Cat C6.6 ACERT
• Low emission diesel engine
• Noise reduction technology
• Smart waste gate turbocharged
• Aftercooled
• Closed Circuit Breather
• Electronically controlled
Air cleaner, dry type
Axle seal guards, integrated
Brakes, enclosed wet-disc full hydraulic
Differentials, conventional (front/rear)
Driveshaft, lubed for life
Electric fuel prime pump
Engine speed control
Fuel/water separator
Muffler
Radiator, unit serviceable
S•O•S oil sampling port, engine oil
S•O•S oil sampling port, transmission oil
Torque converter
Transmission, 4F/3R, autoshift, single lever control with F/N/R and kickdown button
Transmission neutralizer; operator programmable

HYDRAULICS

Hydraulic diagnostic connectors
Heavy duty hydraulic oil cooler
Hydraulic control, 2-valve, 1-lever with F/N/R
Hydraulics, third function
Load-sensing steering system
S•O•SSM oil sampling port, hydraulic oil

OTHER STANDARD EQUIPMENT

Antifreeze/coolant, extended-life protects to -36° C (-33° F)
Automatic bucket positioner/fork positioner
Brakes, secondary and parking
Counterweight
Engine enclosure, lockable
Fenders, front
Hitch, recovery
Loader linkage, z-bar
Lift kickout, automatic
Machine Security System ready
Product Link ready
Remote grease lines
Steering stops, cushioned
Swing-out, hydraulically driven demand fan
Vandalism protection, lockable service points
Visual indicators:
• air cleaner service
• coolant level
• hydraulic oil
• transmission oil

Optional equipment may vary. Consult your Caterpillar dealer for details.

Antifreeze/coolant, extended-life, protects to
-50° C (-58° F)

Axles:

- Front Limited Slip Differential
- Rear Limited Slip Differential
- Rear Limited Slip Differential, with heavy duty brakes (axle oil cooler included)

Beacon light, rotating or strobe,
magnetic-mount

Buckets/ground engaging tools

Canopy, ROPS

Counterweight, additional, optional

Coupler controls and lines

Deluxe Cab arrangement includes:

- External heated mirrors
- Sunscreen
- Sun shade
- Flood lights, auxiliary, cab mounted

Fan, reversing

Fenders, roading, rear

Fenders, steel

Guards:

- Crankcase
- Driveshaft, front
- Power train
- Lights
- Windshield
- Radiator

Hydraulic control auxiliary, third valve

Load check valves (dealer installed)

Machine Security System

Material handling arm

Pallet forks, carriage

Product Link

Quick Coupler

Radiator, wide fin spacing, 5.5 fpi

Radio packages:

- Radio, AM/FM
- Radio, AM/FM with CD player

Rear-view camera system

Ride Control System

Seats:

- Cat Contour Seat, fabric, with adjustable backrest and lumbar support
- Cat Contour Seat, fabric, electrically adjustable with air suspension

Sound suppression package, available in select markets

Starting aid, engine coolant heater, 120V

Steering, secondary

Tires:

- Bias ply, 17.5-25 and 20.5-25
- Radial, 17.5-R25, 20.5-R25 and 600/65 R25

928Hz Wheel Loader

For more complete information on Cat products, dealer services, and industry solutions, visit us on the web at www.cat.com

© 2007 Caterpillar Inc.
All rights reserved
Printed in the U.S.A.

Materials and specifications are subject to change without notice. Featured machines may include additional equipment. See your Caterpillar dealer for available options.

CAT, CATERPILLAR, their respective logos, "Caterpillar Yellow" and the POWER EDGE trade dress, as well as corporate and product identity used herein, are trademarks of Caterpillar and may not be used without permission.

AEHQ5907 (08-2007)
Replaces AEHQ5610-01

CATERPILLAR[®]