

320D/ 320D L

Hydraulic Excavators



Engine

Engine Model	Cat® C6.4 ACERT™	
Net Flywheel Power	103 kW	138 hp

Weights

Operating Weight – Std. Undercarriage	20 350 kg	44,870 lb
------------------------------------------	-----------	-----------

- Reach boom, R2.9B1 (9 ft 6 in) Stick, 0.9 m³ (1.2 yd³)
Bucket, 600 mm (24 in) Shoes

Operating Weight – Long Undercarriage	21 550 kg	47,510 lb
------------------------------------------	-----------	-----------

- Reach boom, R2.9B1 (9 ft 6 in) Stick, 0.9 m³ (1.2 yd³)
Bucket, 800 mm (32 in) Shoes

320D/320D L Hydraulic Excavators

The D Series incorporates innovations for improved performance and versatility.

C6.4 with ACERT™ Technology

- ✓ ACERT™ Technology works at the point of combustion to optimize engine performance and provide low exhaust emissions with exceptional performance capabilities and proven reliability. By combining excellent fuel efficiency and maximized production, 320D will provide unmatched profit potential. **pg. 4**

Versatility

Caterpillar offers a wide variety of factory-installed attachments that enhance performance and job site management. **pg. 11**

Hydraulics

The hydraulic system has been designed to provide reliability and outstanding controllability. An optional Tool Control System provides enhanced flexibility. **pg. 5**

Service and Maintenance

Fast, easy service has been designed in with extended service intervals, advanced filtration, convenient filter access and user-friendly electronic diagnostics for increased productivity and reduced maintenance costs. **pg. 12**

Operator Comfort

- ✓ Provides maximum space, wider visibility and easy access to switches. The monitor is a full-color graphical display that allows the operator to understand the machine information easily. Overall, the new cab provides a comfortable environment for the operator. **pg. 6**



Structures

Caterpillar® design and manufacturing techniques assure outstanding durability and service life from these important components. **pg. 8**

Booms, Sticks and Bucket Linkages

Three lengths of booms and five sticks are available, offering a range of configurations suitable for a wide variety of application conditions. The bucket linkage pins have been enlarged to improve reliability and durability. All Booms and Sticks are stress relieved. **pg. 9**

Work Tools – Attachments

- ✓ A variety of work tools, including buckets, couplers, hammers, and grapples are available through Cat® Work Tools. **pg. 10**

Complete Customer Support

Your Cat® dealer offers a wide range of services that can be set up under a customer support agreement when you purchase your equipment. The dealer will help you choose a plan that can cover everything from machine configuration to eventual replacement. **pg. 13**



✓ *New Feature*

C6.4 with ACERT™ Technology

The Cat® C6.4 gives the 320D exceptional power and fuel efficiency unmatched in the industry for consistently high performance in all applications.



ADEM™ A4 Engine Controller.

The ADEM A4 electronic control module manages fuel delivery to get the best performance per liter of fuel used. The engine management system provides flexible fuel mapping, allowing the engine to respond quickly to varying application needs. It tracks engine and machine conditions while keeping the engine operating at peak efficiency.

Electronic Control Module.

The Electronic Control Module (ECM) works as the “brain” of the engine’s control system, responding quickly to operating variables to maximize engine efficiency. Fully integrated with sensors in the engine’s fuel, air, coolant, and exhaust systems, the ECM stores and relays information on conditions such as rpm, fuel consumption, and diagnostic information.

Fuel Delivery. The Cat C6.4 features electronic controls that govern the fuel injection system. Multiple injection fuel delivery involves a high degree of precision. Precisely shaping the combustion cycle lowers combustion chamber temperatures, generating fewer emissions and optimizing fuel combustion. This translates into more work output for your fuel cost.

Cooling System. The ambient cooling capability of the Cat C6.4 on the 320D is 52° C (125° F) . This can potentially lead to better fuel efficiency and longer hydraulic component life in all ambient conditions.

Cat C6.4. The Cat C6.4 with ACERT™ Technology introduces a series of evolutionary, incremental improvements that provide breakthrough engine technology. The building blocks of ACERT Technology are fuel delivery, air management and electronic control. ACERT Technology optimizes engine performance while meeting global low emission regulations. With its proven technology, robust components and precision manufacturing, you can count on this engine to power up at start time and keep working productively all shift long.

Performance. The 320D, equipped with the C6.4 engine with ACERT™ Technology, provides a speed and efficiency advantage in high production applications. By combining excellent fuel consumption of the C6.4 engine with the Economy Mode, customers can balance the demands of performance and fuel economy to suit their requirements and application.

Automatic Engine Speed Control.

The two-stage, one-touch control reduces sound levels and fuel consumption.

Hydraulics

Cat® hydraulics deliver power and precise control to keep material moving.

Component Layout. To optimize efficiency of hydraulic performance, the hydraulic components are located close together, which reduces friction loss and pressure drops in the lines.

System Pressure. System pressure has been increased to 35 000 kPa (5,076 psi), which attributes to improved performance:

- Increased stick and bucket forces (up 7% higher than the 320C) to better handle those tight digging conditions
- More drawbar pull (206 kN – 46,300 lb) to provide more ability to climb slopes, easier spot turns and improved travel in poor underfoot conditions
- More lift capacity, generally over the front where you are generally hydraulically limited

Pilot System. The pilot pump is independent from the main pumps and controls the front linkage, swing and travel operations.

Hydraulic Cross Sensing System. The hydraulic cross sensing system utilizes each of two hydraulic pumps to 100 percent of engine power, under all operating conditions. This improves productivity with faster implement speeds and quicker, stronger pivot turns.

Boom and Stick Regeneration Circuit. Boom and stick regeneration circuit saves energy during boom-down and stick-in operation which increases efficiency, reduces cycle times and pressure loss for higher productivity, lower operating costs and increased fuel efficiency.



Auxiliary Hydraulic Valve. The auxiliary valve is standard on the 320D. Control Circuits are available as attachments, allowing for operation of high and medium pressure tools such as shears, grapples, hammers, pulverizers, multi-processors and vibratory plate compactors.

Hydraulic Cylinder Snubbers. Snubbers are located at the rod-end of the boom cylinders and both ends of the stick cylinders to cushion shocks while reducing sound levels and extending component life.

Optional Heavy Lift. The optional heavy lift feature on the 320D increases system pressure to 36 000 kPa (5,221 psi), giving even more lift capacity over the front. Heavy Lift is activated by depressing the soft switch on the right hand console. As the pressure increases, the engine speed is reduced, which allows better control while lifting objects.

Operator Comfort

Caterpillar offers the most intuitive and easy to operate excavators while providing great all around visibility and exceptional operator comfort.



Operator Station. The layout of the interior has been redesigned to maximize operator comfort and reduce operator fatigue.

- Frequently used switches have been relocated for easier access.
- Consoles and armrests have been redesigned for better comfort and adjustability.
- More seat options – choose from the low back or high back mechanical suspension seat, the high back air suspension seat or the optional air suspension seat with heater. All provide excellent operator comfort.

Standard Cab Equipment. To enhance operator comfort and productivity, the cab includes a lighter, drink holder, coat hook, service meter, literature holder, magazine rack and storage compartment.

Joystick Control. Joystick controls have low lever effort and are designed to match the operator's natural wrist and arm position.

Hydraulic Activation Control Lever.

For added safety, this lever must be in the operate position to activate the machine control functions.

Automatic Climate Control. Fully automatic climate control adjusts temperature and flow, and determines which air outlet is best in each situation with a touch of a button.

Cab Exterior. The exterior design uses thick steel tubing along the bottom perimeter of the cab, improving the resistance of fatigue and vibration.

Cab Mounts. The cab shell is attached to the frame with viscous rubber cab mounts, which dampen vibrations and sound levels while enhancing operator comfort.

Windows. All glass is affixed directly to the cab for excellent visibility eliminating window frames.



Wipers. Pillar-mounted wipers increase the operator's viewing area and offer continuous and intermittent modes.

Skylight. An enlarged skylight with sunshade provides excellent visibility and ventilation.

Monitor. The vertical monitor enhances operator visibility. The full-color Liquid Crystal Display gives you vital operating and performance information, alerts in text, all in a simple, easy to navigate format delivering information in 27 languages.

Main Menu. Four menu options to choose from:

Settings – Adjust monitor settings, select Economy Mode, work tool or choose video mode (when equipped with a camera)

Maintenance – Displays service intervals and hours accumulated since last serviced.

Performance – Displays machine performance attributes such as Engine Speed, Coolant and Hydraulic Oil Temperature.

Service – Allows access to machine parameters for service intervals, diagnostic information and information related to the machines software.

Pre-Start Check. Prior to starting the machine, the system will check for low fluid levels for the engine oil, hydraulic oil and engine coolant and warn the operator through the monitor in the event display area.

Gauge Display. Three analog gauges, fuel level, hydraulic oil temperature and coolant temperature, are displayed in this area.

Event Display. Machine information is displayed in this area with the icon and language.

Multi-information Display. This area is reserved for displaying various information which is convenient for the operator.

Structures

320D is designed to handle the most rugged operating conditions, while providing long life and value.



Robust Undercarriage. A solid foundation built tough to absorb the stresses of everyday work.

- Rollers and idlers are sealed and lubricated to extend service life.
- Track links are assembled and sealed with grease to decrease internal bushing wear and increase life by as much as 25%, when compared to dry seal undercarriages.
- Spring recoil system stroke has been increased to better relieve excess track tension, which can occur when material builds up between the track and sprocket.

Undercarriage Options. Choose the undercarriage option that best matches your application.

- Standard undercarriage – Works well in restricted work spaces and on uneven, rocky terrain. It's also preferred on jobs that require frequent repositioning of the machine.
- Long undercarriage – Allows for maximum stability and lift capacity.

Rugged Structures. Structural components and the undercarriage are the backbone of the machine's durability. Caterpillar places a lot of emphasis on the machine's durability during the designing and manufacturing of its excavators.

- Up to 95% of the structural welds are welded by robots, which achieve up to three times the penetration of a manual weld and improving overall durability of the machine.
- The 320D's main frame utilizes high-tensile strength steel and a one-piece swing table, which improves strength and reliability.
- The carbody has a X-shaped, box section design to resist bending and twisting forces.
- Track roller frames are press-formed in a pentagonal shape for additional strength.

Booms, Sticks and Bucket Linkages

Built for performance and long service life, Caterpillar® booms and sticks are large, welded, box-section structures with thick, multi-plate fabrications in high stress areas.

Front Linkage Options. The Reach Boom allows excellent all-around versatility and a large working envelope. It can be equipped with the following three sticks:

- R3.9B1 – offers maximum reach and digging depth
- R2.9B1 – performs well in a mid-range working envelope
- R2.5B1 – a good match when the job requires a larger bucket or a hammer

For Heavy-duty applications, heavy-duty reach boom and heavy-duty R2.9B1 and R2.5B1 sticks are available.

Mass Excavation Boom is designed for heavy-duty, high production earthmoving applications and has a single system-matched stick

- M2.4CB2 – delivers significantly higher digging forces and allows the use of large buckets.

Super Long Reach Front – with reaches up to 15.2 meter this configuration is designed for light duty applications requiring an extra large working envelope.



Linkage Pins. All the pins in the front linkages have thick chrome plating, giving them high wear and corrosion resistance. The pins and bushings provide a 1,000 hour greasing interval for boom and stick linkages under normal job conditions.

Bucket Linkage. The power link improves durability, increases machine-lifting capability in key lifting positions and with the integrated lift-eye it is easier to use than compared to the previous power link.

Work Tools – Attachments

The 320D has an extensive selection of work tools to optimize machine performance.



Wide Variety of Work Tools. Caterpillar offers a complete line of work tools to match all of your application needs:

- Hammers – the ideal choice for concrete demolition, demolishing oversize rock, breaking frozen or hard ground, and trenching. Matched to Cat machines for optimum performance.
- Thumbs transform your 320D into a versatile material handling machine.
- Grapples – for handling loose material, sorting trash, and demolition site cleanup. An array of styles and sizes are available to match the task at hand.
- Vibratory Plate Compactors – provide superior compaction force in a reliable, low maintenance package.

Caterpillar Buckets. The most expensive choice of buckets that can optimize machine performance and match your application needs.

- General Purpose Buckets (GP) – Large capacity for digging soft to hard materials, such as dirt, loam, and clay like materials. Not intended for use in abrasive materials or high-impact applications. The shallow profile optimizes bucket capacity for easy to penetrate soils.
- Excavation (X) and Excavation Special (XSP) – for normal excavation work in soft to hard ground with moderate abrasiveness.

- Heavy-Duty Buckets (HD) – for use in materials, such as mixed dirt, clay and rock. Aggressive bucket designed for moderate abrasive applications. The bucket is designed with increased wear material to allow for longer life in abrasive applications.
- Heavy-Duty Power Buckets – for use in abrasive applications where breakout force and cycle times are critical – good for materials such as mixed dirt, clay and rock.
- Ditch Cleaning Buckets – wide and shallow for ditch cleaning, bank forming and finishing.

Caterpillar Ground Engaging Tools (GET).

Choose from a wide variety of tips that maximize bucket and machine performance. Sidecutters and sidebar protectors are also available.



Pin Grabber Plus Hydraulic Pin Grabber

Couplers. Multiply the versatility and utility of 320D.

- Hydraulic Pin Grabber Plus – allows quick and easy tool changes without having to leave the cab. Picks up a large variety of tools equipped with standard pins.
- Dedicated Coupler – no loss of tip radius, maximizing the breakout forces on your 320D.

Versatility

A wide variety of optional factory-installed attachments are available to enhance performance and improve job site management.



Auxiliary Hydraulic Options. Allows you to configure your 320D to meet your work tools needs, while increasing its versatility.

- Single Function Circuit – suited for tools that require one-way flow with both pumps, such as hammers, vibratory plate compactors.
- Common Function Circuit – In addition to the Single Function Circuit, it features one more selection of Double Function Circuit, ideal for tools that require two-way flow and one or two pump output, such as thumbs and non-rotating shears or grapples. Two control options are available, either modulated foot pedal (right-hand side) or joystick controls (on/off, no modulation). Flows can be set through the monitor.

- Tool Control System – accommodates single or double function tools, as well as rotating tools when equipped with medium pressure.
 - Stores pressure and flow information for up to 10 tools
 - Cat tools selectable that have preset flows and pressures
 - Shortcut button on right hand console, making tool selection easier.



Machine Security. An optional Machine Security System is available from the factory on the 320D. This system controls when the machine can be operated and utilizes specific keys to prevent unauthorized machine use, a significant theft deterrent.

Product Link. Both the PL121 and PL321 are available as factory installed attachments. PL121 gives you Asset Watch, which includes the following features:

- Engine hours
- Machine location

- Time based fences (when the machines can operate)
- Geo-based fences (boundaries that the machine can operator) PL321 gives you all of the features listed for PL121, plus the ability to include Health and Maintenance Watch.
- Health Watch
 - Codes from on-board EDM's/Sensors
 - Estimated Fuel Consumption
 - Fuel Watch
- Maintenance Watch
 - Preventative Maintenance Planning
 - Preventative Maintenance Checklists
 - Overdue PM Notification
 - PM History Recording

More Attachments. The 320D offers the most options available to equip your 320D to best match your application and work environment requirements. From track shoe size to guarding packages to operator comfort options, the 320D offers more options.

Service and Maintenance

Simplified service and maintenance features save you time and money.



Ground Level Service. The design and layout of the 320D was made with the service technician in mind. Many service locations are easily accessible at ground level allowing critical maintenance to get done quickly and efficiently. For example, service doors are situated on both sides of the upper structure, which allows for ease of maintenance on items such as the engine radiator or any of the hydraulic components, all reachable from ground level.

The 320D has two service hour meters. One is installed in the monitor, the other is installed on the console permitting ground level reading without starting the engine.

Air Filter Compartment. The air filter features a double-element construction for superior cleaning efficiency. When the air cleaner plugs, a warning is displayed on the monitor screen inside the cab.

Pump Compartment. A service door on the right side allows for ground level access to the hydraulic pump, engine oil filter, case drain and pilot filters.

Greasing Points. A concentrated remote greasing block on the boom delivers grease to hard-to-reach locations on the front.

Capsule Filter. The hydraulic return filter, a capsule filter, is situated outside the hydraulic tank. This filter prevents contaminants from entering the system when hydraulic oil is changed and keeps the operation clean.

Fan Guard. Engine radiator fan is completely enclosed by fine wire mesh, reducing the risk of an accident.

Anti-Skid Plate. Anti-skid plate covers top of storage box and upper structure to prevent slipping during maintenance.

Radiator Compartment. There is wide clearance between the radiator/oil cooler and aftercooler for maintenance. A radiator screen is provided between the radiator/oil cooler and aftercooler for protection. The condenser for the air conditioning system is mounted in front of the radiator/oil cooler and under the aftercooler. Optional swing type condenser is available.

Diagnostics and Monitoring. The 320D is equipped with S•O•SSM sampling ports and hydraulic test ports for the hydraulic system, engine oil, and for coolant. A test connection for the Cat Electronic Technician (Cat ET) service tool is located in the cab.

Extended Service Interval. 320D service and maintenance intervals have been extended to reduce machine service time and increase machine availability.

- Hydraulic oil filter – up to 2,000 hours
- Engine coolant – up to 6,000 hours
- Hydraulic oil – up to 5,000 hours
- Boom foot and front lube – up to 1,000 hours

Complete Customer Support

Cat® dealer services help you operate longer with lower costs.



Product Support. You will find nearly all parts at our dealer parts counter. Cat dealers utilize a worldwide computer network to find in-stock parts to minimize machine down time. Save money with remanufactured components.

Machine Selection. Make detailed comparisons of the machines you are considering before you buy. What are the job requirements, machine attachments and operating hours? What production is needed? Your Cat dealer can provide recommendations.

Customer Support Agreements.

Cat dealers offer a variety of product support agreements, and work with you to develop a plan the best meets specific needs. These plans can cover the entire machine, including attachments, to help protect your investment.

Operation. Improving operating techniques can boost your profits. Your Cat dealer has videotapes, literature and other ideas to help you increase productivity, and Caterpillar offers certified operator training classes to help maximize the return on your investment.

Maintenance Services. Repair option programs guarantee the cost of repairs up front. Diagnostic programs such as Scheduled Oil Sampling, Coolant Sampling and Technical Analysis help you avoid unscheduled repairs.

Replacement. Repair, rebuild, or replace? Your Cat dealer can help you evaluate the cost involved so you can make the right choice.

Engine

Engine Model	Cat® C6.4 ACERT™	
Net Flywheel Power	103 kW	138 hp
Net Power – ISO 9249	103 kW	138 hp
Net Power – SAE J1349	103 kW	138 hp
Net Power – EEC 80/1269	103 kW	138 hp
Bore	102 mm	4.02 in
Stroke	130 mm	5.12 in
Displacement	6.4 L	389 in ³

- The C6.4 ACERT meets exhaust emissions equivalent to USA EPA Tier 2 and EU Stage II engine emissions regulations
- Net flywheel power advertised is the power available at the flywheel when the engine is equipped with fan, air cleaner, muffler and alternator.
- No engine power derated below 2300 m (7,500 ft).

Weights

Operating Weight – Std. Undercarriage	20 350 kg	44,870 lb
Operating Weight – Long Undercarriage	21 550 kg	47,510 lb

- Reach boom, R2.9B1 (9 ft 6 in) Stick, 0.9 m³ (1.2 yd³) Bucket, 600 mm (24 in) Shoes
- Reach boom, R2.9B1 (9 ft 6 in) Stick, 0.9 m³ (1.2 yd³) Bucket, 800 mm (32 in) Shoes

Service Refill Capacities

Fuel Tank Capacity	410 L	108 gal
Cooling System	25 L	6.6 gal
Engine Oil	30 L	8 gal
Swing Drive	8 L	2.1 gal
Final Drive (each)	10 L	2.6 gal
Hydraulic System (including tank)	260 L	69 gal
Hydraulic Tank	120 L	32 gal
Hydraulic Tank (including suction pipe)	138 L	36 gal

Swing Mechanism

Swing Speed	11.5 rpm	
Swing Torque	62 kN·m	45,600 lb ft

Drive

Maximum Drawbar Pull	206 kN	46,300 lb
Maximum Travel Speed	5.5 km/h	3.4 mph

Hydraulic System

Main Implement System – Maximum Flow (2x)	205 L/min	54 gal/min
Max. Pressure – Equipment	35 000 kPa	5,076 psi
Max. Pressure – Equipment – Heavy Lift	36 000 kPa	5,221 psi
Max. Pressure – Travel	35 000 kPa	5,076 psi
Max. Pressure – Swing	24 500 kPa	3,553 psi
Pilot System – Maximum Flow	32.4 L/min	9 gal/min
Pilot System – Maximum Pressure	3900 kPa	566 psi
Boom Cylinder – Bore	120 mm	4.7 in
Boom Cylinder – Stroke	1260 mm	49.6 in
Reach Stick Cylinder – Bore	140 mm	5.5 in
Mass Stick Cylinder – Bore	140 mm	5.5 in
Reach Stick Cylinder – Stroke	1504 mm	59.2 in
Mass Stick Cylinder – Stroke	1504 mm	59.2 in
B1 Family Bucket Cylinder – Bore	120 mm	4.7 in
B1 Family Bucket Cylinder – Stroke	1104 mm	43.5 in
CB2 Family Bucket Cylinder – Bore	135 mm	5.3 in
CB2 Family Bucket Cylinder – Stroke	1156 mm	45.5 in

Sound Performance

Performance ANSI/SAE J1166 OCT 98

- When properly installed and maintained, the cab offered by Caterpillar, when tested with doors and windows closed according to ANSI/SAE J1166 OCT 98, meets OSHA and MSHA requirements for operator sound exposure limits in effect at time of manufacture.
- Hearing protection may be needed when operating with an open operator station and cab (when not properly maintained or doors/windows open) for extended periods or in noisy environment.

Standards

Brakes	SAE J1026 APR90
Cab/FOGS	SAE J1356 FEB88

Dimensions

All dimensions are approximate.

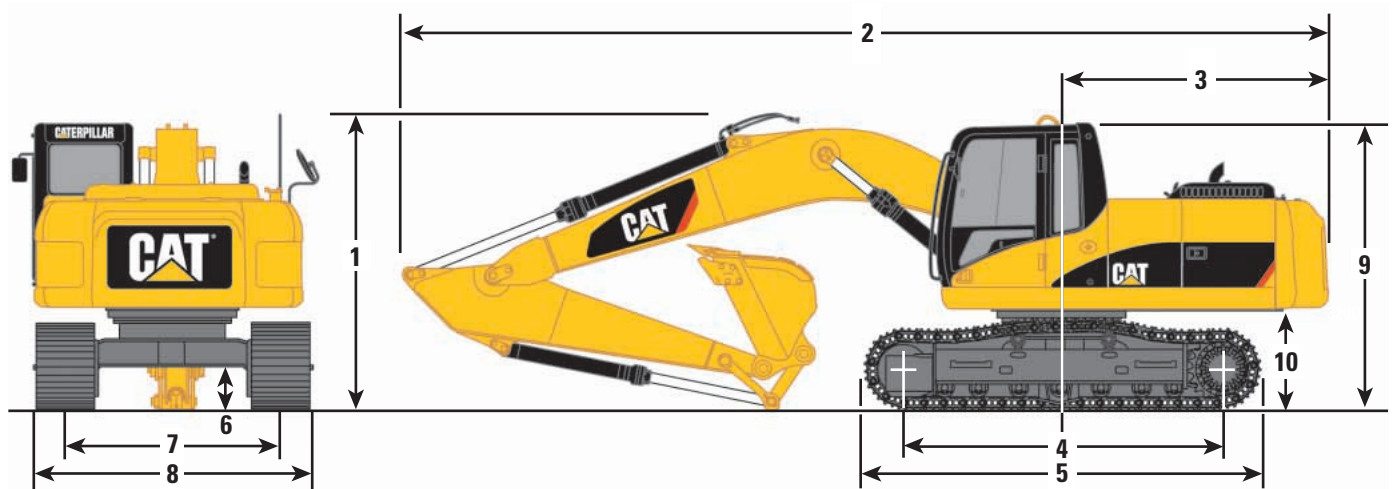

Boom Options	Reach 5.7 m (18'7")	Reach 5.7 m (18'7")	Reach 5.7 m (18'7")	Mass 5.2 m (17'1")	Super Long Reach 8.85 m (29'1")
Stick Options	R3.9B1 (12'8")	R2.9B1 (9'7")	R2.5B1 (8'2")	M2.4CB2 (7'10")	6.28 m (20'7")
1 Shipping Height*	3440 mm (11'3")	3030 mm (9'11")	3050 mm (10'0")	3280 mm (10'9")	3190 mm (10'6")
2 Shipping Length	9440 mm (31'0")	9460 mm (31'0")	9460 mm (31'0")	9050 mm (29'8")	12 680 mm (41'7")
3 Tail Swing Radius	2750 mm (9'0")	2750 mm (9'0")	2750 mm (9'0")	2750 mm (9'0")	2750 mm (9'0")
4 Length to Center of Rollers					
Standard	3265 mm (10'9")	3265 mm (10'9")	3265 mm (10'9")	3265 mm (10'9")	n/a
Long	3650 mm (12'0")	3650 mm (12'0")	3650 mm (12'0")	3650 mm (12'0")	3650 mm (12'0")
5 Track Length					
Standard	4075 mm (13'4")	4075 mm (13'4")	4075 mm (13'4")	4075 mm (13'4")	n/a
Long	4455 mm (14'7")	4455 mm (14'7")	4455 mm (14'7")	4455 mm (14'7")	4455 mm (14'7")
6 Ground Clearance**	450 mm (1'6")	450 mm (1'6")	450 mm (1'6")	450 mm (1'6")	450 mm (1'6")
7 Track Gauge					
Standard	2200 mm (7'3")	2200 mm (7'3")	2200 mm (7'3")	2200 mm (7'3")	n/a
Long	2380 mm (7'10")	2380 mm (7'10")	2380 mm (7'10")	2380 mm (7'10")	2380 mm (7'10")
8 Transport Width	800 mm Shoes	700 mm Shoes	600 mm Shoes	600 mm Shoes	800 mm Shoes
Standard	3000 mm (9'10")	2900 mm (9'6")	2800 mm (9'2")	2800 mm (9'2")	n/a
Long	3180 mm (10'5")	3080 mm (10'1")	2980 mm (9'9")	2980 mm (9'9")	3180 mm (10'5")
9 Cab Height*	2950 mm (9'8")	2950 mm (9'8")	2950 mm (9'8")	2950 mm (9'8")	2950 mm (9'8")
10 Counterweight Clearance**	1020 mm (3'4")	1020 mm (3'4")	1020 mm (3'4")	1020 mm (3'4")	1020 mm (3'4")

* Includes 30 mm shoe lug height.

** Without 30 mm shoe lug height.

Reach Excavator Working Ranges

Reach (R) boom configuration

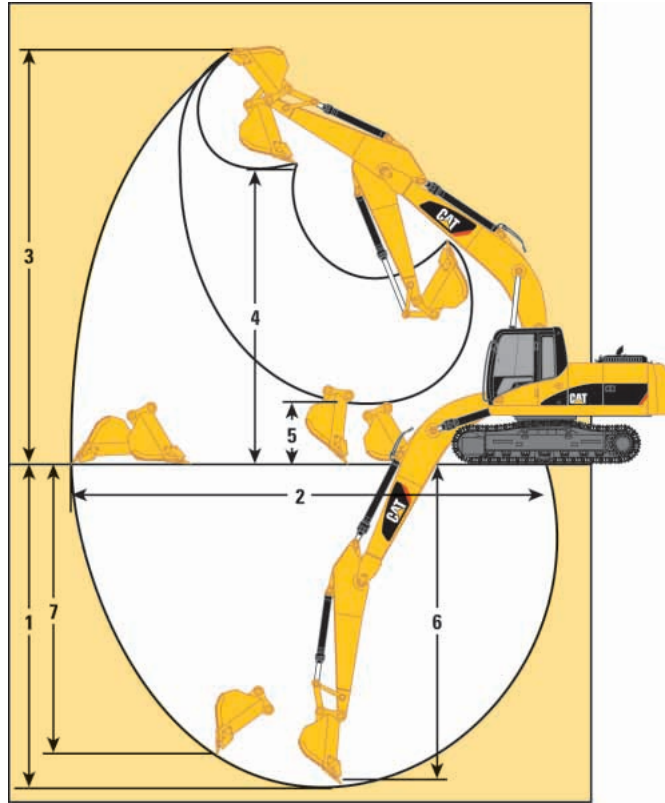

Boom Options	Reach 5.7 m (18'7")	Reach 5.7 m (18'7")	Reach 5.7 m (18'7")
Stick Options	R3.9B1 (12'8")	R2.9B1 (9'7")	R2.5B1 (8'2")
Bucket	0.8 m ³ (1.05 yd ³)	0.9 m ³ (1.2 yd ³)	0.9 m ³ (1.2 yd ³)
1 Maximum Digging Depth	7580 mm (24'10")	6640 mm (21'9")	6220 mm (20'5")
2 Maximum Reach at Ground Level	10 680 mm (35'0")	9780 mm (32'1")	9380 mm (30'9")
3 Maximum Cutting Height	9870 mm (32'5")	9410 mm (30'10")	9210 mm (30'3")
4 Maximum Loading Height	7020 mm (23'0")	6570 mm (21'7")	6370 mm (20'11")
5 Minimum Loading Height	1310 mm (4'4")	2250 mm (7'5")	2870 mm (9'5")
6 Maximum Depth Cut for 2440 m (8') Level Bottom	7440 mm (24'5")	6470 mm (21'3")	6030 mm (19'9")
7 Maximum Vertical Wall Digging Depth	6960 mm (22'10")	6050 mm (19'10")	5640 mm (18'6")
Bucket Digging Force (SAE)	131 kN (29,450 lb)	131 kN (29,450 lb)	131 kN (29,450 lb)
(ISO)	149 kN (33,497 lb)	149 kN (33,497 lb)	149 kN (33,497 lb)
Stick Digging Force (SAE)	86 kN (19,334 lb)	105 kN (23,605 lb)	117 kN (26,303 lb)
(ISO)	89 kN (20,008 lb)	109 kN (24,504 lb)	121 kN (27,202 lb)

All measurements are approximate

Mass Excavator Working Ranges

Mass (M) boom configuration

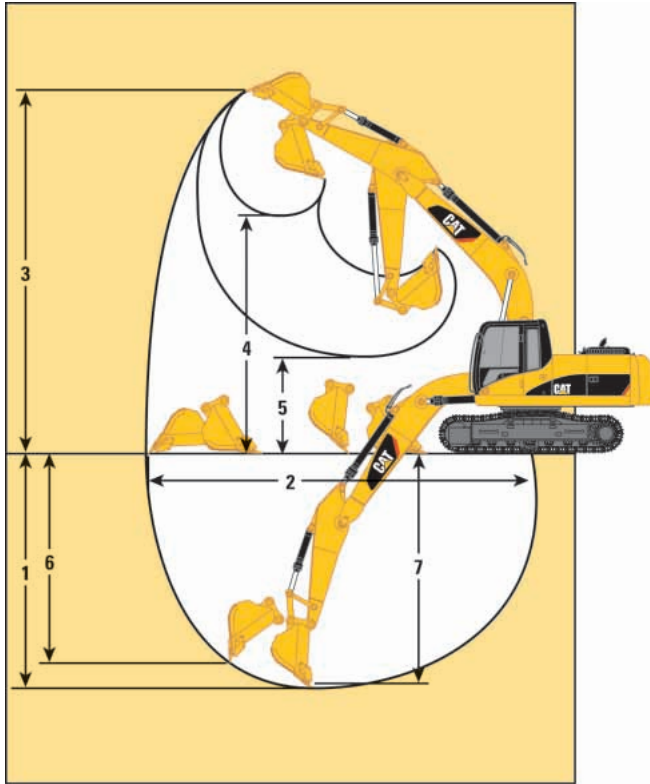

Super Long Reach Working Ranges

Super Long Reach configuration

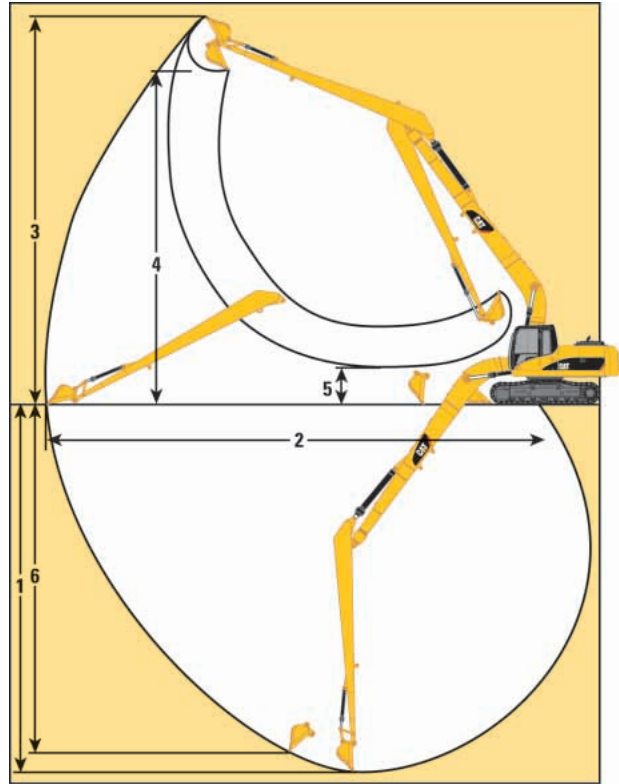

Boom Options	Mass 5.2 m (17'1")	Super Long Reach 8.85 m (29'1")	
Stick Options	M2.4CB2 (7'10")	6.28 m (20'7")	
Bucket	Excavation 1.2 m ³ (1.6 yd ³)	Excavation 0.45 m ³ (0.60 yd ³)	Ditch Cleaning 0.60 m ³ (0.80 yd ³)
1 Maximum Digging Depth	5780 mm (19'0")	11 880 mm (39'0")	11 750 mm (38'7")
2 Maximum Reach at Ground Level	8850 mm (29'0")	15 720 mm (51'7")	15 590 mm (51'2")
3 Maximum Cutting Height	8810 mm (28'1")	13 290 mm (43'7")	13 230 mm (43'5")
4 Maximum Loading Height	5830 mm (19'2")	11 010 mm (36'1")	11 140 mm (36'6")
5 Minimum Loading Height	2340 mm (7'8")	1970 mm (6'6")	2090 mm (6'1")
6 Maximum Vertical Wall Digging Depth	5030 mm (16'6")	10 700 mm (35'1")	11 310 mm (37'1")
7 Maximum Depth Cut for 2440 m (8') Level Bottom	5570 mm (18'3")	—	—
Bucket Digging Force (SAE)	166 kN (37,318 lb)	54 kN (12,100 lb)	60 kN (13,500 lb)
(ISO)	188 kN (42,264 lb)	60 kN (13,500 lb)	60 kN (13,500 lb)
Stick Digging Force (SAE)	125 kN (28,101 lb)	46 kN (10,300 lb)	46 kN (10,300 lb)
(ISO)	130 kN (29,225 lb)	46 kN (10,300 lb)	46 kN (10,300 lb)

All measurements are approximate

320D Bucket Specifications and Compatibility

	Capacity		Width		Tip Radius		Weight (with tips)		Teeth Qty	Reach Boom Stick			HD Reach Boom Stick		Mass Boom Stick M2.4CB2
	m ³	yd ³	mm	in	mm	in	kg	lb		R3.9B1	R2.9B1	R2.5B1	R2.9 HD	R2.5HD	
B1 Family															
Excavation	0.8	1.0	1000	39.4	1497	58.9	675	1,488	5	☉	●	●	●	●	—
	0.9	1.2	1120	44.1	1497	58.9	715	1,576	5	○	●	●	●	●	—
Excavation Special	0.8	1.0	990	39.0	1508	59.4	765	1,687	5	○	●	●	●	●	—
	0.9	1.2	1110	43.7	1508	59.4	830	1,830	5	☉	☉	●	☉	●	—
General Purpose	0.9	1.2	1224	48.2	1480	58.3	772	1,702	6	○	●	●	●	●	—
	1.0	1.3	1224	48.2	1580	62.2	795	1,753	6	○	●	●	●	●	—
Heavy Duty	1.0	1.3	1072	42.2	1577	62.1	866	1,909	5	☉	☉	●	☉	●	—
CB Family															
Excavation	1.1	1.4	1345	53.0	1586	62.4	885	1,951	5	—	—	—	—	—	●
	1.2	1.6	1435	56.5	1586	62.4	919	2,026	5	—	—	—	—	—	●

Assumptions for maximum material density rating:

1. Front linkage fully extended at ground line
2. Bucket curled
3. 100% bucket fill factor

- 2100 kg/m³ (3,500 lb/yd³) max material density
- ☉ 1800 kg/m³ (3,000 lb/yd³) max material density
- 1500 kg/m³ (2,500 lb/yd³) max material density
- 1200 kg/m³ (2,000 lb/yd³) max material density
- Not Available/Recommended

320D L Bucket Specifications and Compatibility

	Capacity		Width		Tip Radius		Weight (with tips)		Teeth Qty	Reach Boom Stick			HD Reach Boom Stick		Mass Boom Stick M2.4CB2
	m ³	yd ³	mm	in	mm	in	kg	lb		R3.9B1	R2.9B1	R2.5B1	R2.9 HD	R2.5HD	
B1 Family															
Excavation	0.8	1.0	1000	39.4	1497	58.9	675	1,488	5	☉	●	●	●	●	—
	0.9	1.2	1120	44.1	1497	58.9	715	1,576	5	○	●	●	●	●	—
Excavation Special	0.8	1.0	990	39.0	1508	59.4	765	1,687	5	○	●	●	●	●	—
	0.9	1.2	1110	43.7	1508	59.4	830	1,830	5	☉	●	●	●	●	—
General Purpose	0.9	1.2	1224	48.2	1480	58.3	772	1,702	6	○	●	●	●	●	—
	1.0	1.3	1224	48.2	1580	62.2	795	1,753	6	○	●	●	●	●	—
Heavy Duty	1.0	1.3	1072	42.2	1577	62.1	866	1,909	5	☉	●	●	●	●	—
CB Family															
Excavation	1.1	1.4	1345	53.0	1586	62.4	885	1,951	5	—	—	—	—	—	●
	1.2	1.6	1435	56.5	1586	62.4	919	2,026	5	—	—	—	—	—	●

Assumptions for maximum material density rating:

1. Front linkage fully extended at ground line
2. Bucket curled
3. 100% bucket fill factor

- 2100 kg/m³ (3,500 lb/yd³) max material density
- ☉ 1800 kg/m³ (3,000 lb/yd³) max material density
- 1500 kg/m³ (2,500 lb/yd³) max material density
- 1200 kg/m³ (2,000 lb/yd³) max material density
- Not Available/Recommended

Major Component Weights

		kg	lb
Base machine with counterweight (without front linkage)	STD undercarriage with 600 mm shoe	16 260	35,847
	L undercarriage with 800 mm shoe	17 470	38,515
Two boom cylinders (Each)		182	401
Counterweight			
Standard		3860	8,510
Super Long Reach		4830	10,648
Boom (includes lines, pins and stick cylinder)			
Reach boom 5.7 m (18'7")		1640	3,616
Mass boom 5.2 m (17'1")		1670	3,682
Super Long Reach Boom – 8.85 m (29'1")		2180	4,806
Stick (includes lines, pins, bucket cylinder and linkage)			
R3.9 (12'8")		1063	2,344
R2.9 (9'7")		818	1,803
R2.5 (8'2")		779	1,717
M2.4 (7'10")		985	2,172
Super Long Reach Stick – 6.82 m (20'7")		1600	3,527
Undercarriage [includes Carbody, Swing bearing, Track frame, Rollers, Idlers, Steps, Guards, Final drive]	STD undercarriage with 600 mm shoe	6670	14,705
	L undercarriage with 800 mm shoe	7880	17,372

320D/320D L Work Tool Matching Guide

Boom Options	Reach Boom 5.7 m (18'7")			Mass Boom 5.2 m (17'1")
Stick Options	R3.9B1 (12'8")	R2.9B1 (9'7")	R2.5B1 (8'2")	M2.4CB2 (7'10")
Hydraulic Hammer	H115s/ H120Cs/ H130s	H115s/ H120Cs/ H130s	H115s/ H120Cs/ H130s	H115s/ H120Cs/ H130s
Vibratory Plate Compactor	CVP110	CVP110	CVP110	CVP110
Trash Grapple	2.7 m ³ (3.5 yd ³)	2.7 m ³ (3.5 yd ³)	2.7 m ³ (3.5 yd ³)	2.7 m ³ (3.5 yd ³)
Contractor's Grapple	yes	yes	yes	n/a
Hydraulic Thumb	yes	yes	yes	n/a
Dedicated Quick Coupler	yes	yes	yes	yes
Pin-Grabber Quick Coupler	yes	yes	yes	yes

Reach Boom Lift Capacities



Load Point Height



Load Radius Over Front



Load Radius Over Side

















Load at Maximum Reach

R2.92B1 STICK – 2.9 m (9'7")
BUCKET – 0.9 m³ (1.2 yd³)

UNDERCARRIAGE – Long
SHOES – 600 mm (24") triple grouser

BOOM – 5.7 m (18'7")















	1.5 m (5.0 ft)		3.0 m (10.0 ft)		4.5 m (15.0 ft)		6.0 m (20.0 ft)		7.5 m (25.0 ft)				m ft	
														
7.5 m 25.0 ft	kg lb											*2150 *4,700	*2150 *4,700	7.75 25.10
6.0 m 20.0 ft	kg lb								*3350 3150			*2000 *4,450	*2000 *4,450	8.73 28.47
4.5 m 15.0 ft	kg lb						*4650 *10,150	4650 10,000	*4400 *9,550	3150 6,700		*2000 *4,400	*2000 *4,400	9.30 30.44
3.0 m 10.0 ft	kg lb		*11 050 *23,500	*11 050 *23,500	*7050 *15,100	7050 *15,100	*5500 *11,950	4450 9,500	*4800 *10,400	3050 6,500		*2100 *4,550	1950 4,300	9.56 31.34
1.5 m 5.0 ft	kg lb				*8800 *19,000	6500 13,950	*6450 *13,900	4200 8,950	4850 10,400	2900 6,250		*2250 *4,900	1950 4,250	9.53 31.28
Ground Line	kg lb		*6350 *14,550	*6350 *14,550	*9950 *21,500	6150 13,150	6750 14,450	4000 8,550	4750 10,150	2800 6,050		*2500 *5,500	2000 4,400	9.22 30.26
-1.5 m -5.0 ft	kg lb	*5850 *13,050	*5850 *13,050	*9800 *22,300	*9800 *22,300	*10 250 *22,200	6000 12,900	6650 14,200	3900 8,350	4700 10,050	2750 5,950	*2950 *6,500	2250 5,000	8.60 28.17
-3.0 m -10.0 ft	kg lb	*9800 *22,000	*9800 *22,000	*14 350 *31,050	12 000 25,650	*9800 *21,150	6050 12,950	6650 14,250	3900 8,350			*3750 *8,300	2800 6,250	7.58 24.72
-4.5 m -15.0 ft	kg lb			*11 850 *25,450	*11 850 *25,450	*8300 *17,750	6200 13,350					*4300 *9,500	4300 *9,500	5.93 19.24

* Limited by hydraulic capacity rather than tipping load. The above loads are in compliance with SAE hydraulic excavator lift capacity rating standard J1097. They do not exceed 87% of hydraulic lifting capacity or 75% of tipping capacity. Weight of all lifting accessories must be deducted from the above lifting capacities.

R2.5B1 STICK – 2.5 m (8'3")
BUCKET – 0.9 m³ (1.2 yd³)

UNDERCARRIAGE – Long
SHOES – 600 mm (24") triple grouser

BOOM – 5.7 m (18'7")

	1.5 m (5.0 ft)		3.0 m (10.0 ft)		4.5 m (15.0 ft)		6.0 m (20.0 ft)		7.5 m (25.0 ft)				m ft	
														
7.5 m 25.0 ft	kg lb						*4150 *9,150	*4150 *9,150				*2500 *5,550	*2500 *5,550	7.24 23.39
6.0 m 20.0 ft	kg lb						*4550 *9,950	*4550 *9,950				*2400 *5,250	*2400 *5,250	8.29 27.02
4.5 m 15.0 ft	kg lb						*5050 *10,950	4600 9,850	*4700 *10,150	3100 6,600		*2400 *5,200	2300 5,100	8.89 29.11
3.0 m 10.0 ft	kg lb				*7600 *16,350	6900 14,800	*5850 *12,650	4400 9,400	4950 10,600	3000 6,450		*2450 *5,400	2100 4,650	9.16 30.05
1.5 m 5.0 ft	kg lb				*9250 *19,900	6350 13,700	*6700 *14,450	4150 8,900	4850 10,350	2900 6,200		*2650 *5,800	2100 4,550	9.14 29.99
Ground Line	kg lb		*5650 *13,050	*5650 *13,050	*10 150 *21,900	6100 13,050	6700 14,400	3950 8,500	4750 10,150	2850 6,050		*2950 *6,500	2200 4,800	8.81 28.92
-1.5 m -5.0 ft	kg lb	*6350 *14,200	*6350 *14,200	*10 350 *23,500	*10 350 *23,500	*10 200 *22,100	6000 12,900	6650 14,250	3900 8,350	4700 10,100	2800 6,000	*3500 *7,700	2500 5,500	8.15 26.71
-3.0 m -10.0 ft	kg lb	*11 150 *25,050	*11 150 *25,050	*13 600 *29,400	12 100 25,850	*9500 *20,500	6100 13,050	6700 14,350	3950 8,450			*4500 *9,950	3200 7,100	7.05 22.99
-4.5 m -15.0 ft	kg lb			*10 700 *22,900	*10 700 *22,900	*7600 *16,100	6300 13,600					*5750 *12,650	4700 10,600	5.50 17.76

* Limited by hydraulic capacity rather than tipping load. The above loads are in compliance with SAE hydraulic excavator lift capacity rating standard J1097. They do not exceed 87% of hydraulic lifting capacity or 75% of tipping capacity. Weight of all lifting accessories must be deducted from the above lifting capacities.

Reach Boom Lift Capacities



Load Point Height



Load Radius Over Front



Load Radius Over Side













Load at Maximum Reach

R2.92B1 STICK – 2.9 m (9'7")
BUCKET – 0.8 m³ (1.0 yd³)

UNDERCARRIAGE – Standard
SHOES – 600 mm (24") triple grouser

BOOM – 5.7 m (18'7")

		1.5 m (5.0 ft)		3.0 m (10.0 ft)		4.5 m (15.0 ft)		6.0 m (20.0 ft)		7.5 m (25.0 ft)				m ft
														
7.5 m 25.0 ft	kg lb											*2150 *4,750	*2150 *4,750	7.75 25.10
6.0 m 20.0 ft	kg lb									*3350	2850	*2050 *4,500	*2050 *4,500	8.73 28.47
4.5 m 15.0 ft	kg lb							*4700 *10,200	4200 9,000	4300 9,200	2800 6,000	*2050 *4,500	1900 4,200	9.30 30.44
3.0 m 10.0 ft	kg lb			*11 100 *23,550	*11 100 *23,550	*7050 *15,150	6300 13,550	*5550 *12,000	4000 8,550	4200 9,000	2700 5,800	*2100 *4,650	1750 3,850	9.56 31.34
1.5 m 5.0 ft	kg lb					*8850 *19,050	5750 12,350	5850 12,500	3750 8,000	4100 8,750	2600 5,550	*2300 *5,000	1700 3,750	9.53 31.28
Ground Line	kg lb			*6400 *14,600	*6400 *14,600	8900 19,050	5400 11,650	5600 12,050	3550 7,600	3950 8,500	2500 5,350	*2550 *5,550	1800 3,900	9.22 30.26
-1.5 m -5.0 ft	kg lb	*5900 *13,100	*5900 *13,100	*9850 *22,350	*9850 *21,850	8750 18,700	5300 11,350	5500 11,850	3450 7,400	3900 8,400	2450 5,250	*3000 *6,550	2000 4,400	8.60 28.17
-3.0 m -10.0 ft	kg lb	*9850 *22,050	*9850 *22,050	*14 350 *31,100	10 400 22,250	8750 18,800	5300 11,450	5500 11,850	3450 7,400			*3800 *8,400	2500 5,600	7.58 24.72
-4.5 m -15.0 ft	kg lb			*11 900 *25,500	10 750 23,000	*8350 *17,800	5500 11,800					*4350 *9,600	3850 8,550	5.93 19.24

* Limited by hydraulic capacity rather than tipping load. The above loads are in compliance with SAE hydraulic excavator lift capacity rating standard J1097. They do not exceed 87% of hydraulic lifting capacity or 75% of tipping capacity. Weight of all lifting accessories must be deducted from the above lifting capacities.

Mass Boom Lift Capacities



Load Point Height



Load Radius Over Front



Load Radius Over Side













Load at Maximum Reach

M2.4CB2 STICK – 2.4 m (7'11")
BUCKET – 1.2 m³ (1.6 yd³)

UNDERCARRIAGE – Long
SHOES – 600 mm (24") triple grouser

BOOM – 5.2 m (17'1")

		1.5 m (5.0 ft)		3.0 m (10.0 ft)		4.5 m (15.0 ft)		6.0 m (20.0 ft)		7.5 m (25.0 ft)				m ft
														
7.5 m 25.0 ft	kg lb											*3250 *3250	*3250 *3250	6.51
6.0 m 20.0 ft	kg lb							*4650 *10,250	4400 9,350			*3050 *6,650	2800 6,200	7.69 25.03
4.5 m 15.0 ft	kg lb							*5000 *10,850	4300 9,200			*3050 *6,650	2300 5,050	8.34 27.30
3.0 m 10.0 ft	kg lb					*7250 *15,550	6700 14,450	*5700 *12,300	4100 8,800	4650 9,850	2700 5,700	*3150 *6,900	2050 4,500	8.63 28.29
1.5 m 5.0 ft	kg lb					*8850 *19,050	6150 13,250	*6450 *13,950	3850 8,300	4550 9,700	2600 5,550	*3450 *7,550	2000 4,400	8.58 28.17
Ground Line	kg lb			*8550 *19,650	*8550 *19,650	*9750 *21,100	5800 12,500	6450 13,850	3700 7,900	4450 9,700	2550 5,550	3800 8,400	2150 4,700	8.22 26.96
-1.5 m -5.0 ft	kg lb	*7800 *17,400	*7800 *17,400	*14 050 *32,000	11 450 24,500	*9800 *21,200	5700 12,250	6400 13,700	3650 7,750			4500 9,950	2550 5,650	7.48 24.47
-3.0 m -10.0 ft	kg lb	*13 850 *31,200	*13 850 *31,200	*12 850 *27,800	11 800 25,200	*8850 *19,000	5800 12,500	*6100 13,700	3700 8,100			*4600 *10,050	3650 8,100	6.20 20.18
-4.5 m -15.0 ft	kg lb											*5850 *12,850	*5850 *12,850	4.47

* Limited by hydraulic capacity rather than tipping load. The above loads are in compliance with SAE hydraulic excavator lift capacity rating standard J1097. They do not exceed 87% of hydraulic lifting capacity or 75% of tipping capacity. Weight of all lifting accessories must be deducted from the above lifting capacities.

Super Long Reach Boom Lift Capacities



Load Point Height



Load Radius Over Front



Load Radius Over Side



Load at Maximum Reach

SUPER LONG REACH STICK – 6.28 m (20'7")



















UNDERCARRIAGE – Long

BOOM – 8.85 m (29'0")

BUCKET – 1142 mm (45") Ditch Cleaning Bucket

SHOES – 800 mm (32") triple grouser

COUNTERWEIGHT – 4.82 ton (10,624 lb)

	4.5 m (15.0 ft)		6.0 m (20.0 ft)		7.5 m (25.0 ft)		9.0 m (30.0 ft)		10.5 m (35.0 ft)		12.0 m (40.0 ft)		13.5 m (45.0 ft)				m ft	
																		
12.0 m 40.0 ft	kg lb															*800 *1,800	*800 *1,800	11.54 37.25
10.5 m 35.0 ft	kg lb															*750 *1,650	*750 *1,650	12.78 41.52
9.0 m 30.0 ft	kg lb											*1850 *3,550	1800 *3,550			*700 *1,550	*700 *1,550	13.72 44.74
7.5 m 25.0 ft	kg lb									*4,050 *4,050	*4,050 *4,050	*1850 *4,050	1800 3,750	*1000 *1000		*700 *1,550	*700 *1,550	14.42 47.15
6.0 m 20.0 ft	kg lb									*2000 *4,350	*2000 *4,350	*1950 *4,250	1750 3,650	*1750 *3,200	1300 2,700	*700 *1,550	*700 *1,550	14.92 48.87
4.5 m 15.0 ft	kg lb						*2400 *5,150	*2400 *5,150	*2200 *4,800	2150 4,600	*2050 *4,500	1650 3,500	*2000 *4,350	1250 2,650	*750 *1,550	*750 *1,550	15.24 49.98	
3.0 m 10.0 ft	kg lb			*3950 *8,450	*3950 *8,450	*3200 *6,850	*3200 *6,850	*2750 *5,900	2650 5,700	*2450 *5,250	2000 4,300	*2250 *4,850	1550 3,300	*2100 *4,550	1200 2,550	*750 *1,650	*750 *1,650	15.40 50.52
1.5 m 5.0 ft	kg lb	*6950 *14,850	6550 14,100	*4800 *10,300	4450 9,550	*3700 *8,000	3200 6,900	*3100 *6,650	2450 5,200	*2650 *5,800	1850 4,000	*2400 *5,200	1450 3,100	2050 4,400	1150 2,400	*800 *1,750	*800 *1,750	15.40 50.53
Ground Line	kg lb	*4650 *10,650	*4650 *10,650	*5500 *11,900	3950 8,500	*4200 *9,050	2900 6,250	*3400 *7,350	2250 4,750	*2900 *6,250	1750 3,700	2450 5,250	1350 2,900	2000 4,300	1100 2,300	*850 *1,900	850 1,850	15.24 49.99
-1.5 m -5.0 ft	kg lb	*4450 *10,050	*4450 *10,050	*6000 *12,950	3650 7,850	*4550 *9,850	2700 5,800	3650 7,850	2100 4,450	*2900 *6,250	1650 3,450	2350 5,050	1300 2,750	1950 4,200	1050 2,200	*950 *2,100	850 1,900	14.91 48.89
-3.0 m -10.0 ft	kg lb	*4900 *11,050	*4900 *11,050	*6250 *13,500	3500 7,550	4600 9,900	2550 5,500	3550 7,600	1950 4,200	2850 6,050	1550 3,300	2300 4,950	1250 2,650	1950 4,150	1000 2,150	*1100 *2,350	900 2,000	14.40 47.19
-4.5 m -15.0 ft	kg lb	*5700 *12,850	5350 11,450	*6300 *13,600	3450 7,450	4550 9,750	2500 5,350	3500 7,500	1900 4,100	2800 6,000	1500 3,250	2300 4,900	1250 2,600			*1250 *2,750	1000 2,250	13.70 44.81
-6.0 m -20.0 ft	kg lb	*6750 *15,300	5450 11,700	*6150 *13,250	3500 7,500	4550 9,750	2500 5,400	3500 7,500	1900 4,100	2800 6,000	1500 3,250	2300 5,000	1250 2,650			*1500 *3,400	1200 2,600	12.76 41.64
-7.5 m -25.0 ft	kg lb	*7600 *16,300	5600 12,100	*5750 *12,400	3600 7,700	*4550 *9,800	2550 5,500	3550 7,600	1950 4,200	2850 6,150	1600 3,400					*1950 *4,400	1450 3,200	11.53 37.46
-9.0 m -30.0 ft	kg lb	*6600 *14,100	5900 12,700	*5100 *10,850	3750 8,100	*4050 *8,600	2700 5,850	*3200 *6,750	2100 4,500							*2400 *5,300	1950 4,400	9.89 31.84
-10.5 m -35.0 ft	kg lb	*5100 *11,200	*5100 *11,200	*3950 *8,200	*3950 *8,200	*3050 *6,150	2950 *6,150									*2650 *5,750	2600 *5,750	8.18 25.98

* Limited by hydraulic capacity rather than tipping load. The above loads are in compliance with SAE hydraulic excavator lift capacity rating standard J1097. They do not exceed 87% of hydraulic lifting capacity or 75% of tipping capacity. Weight of all lifting accessories must be deducted from the above lifting capacities.

Always refer to the appropriate Operation and Maintenance Manual for specific product information.

Standard Equipment

Standard equipment may vary. Consult your Caterpillar dealer for details.

Electrical

- Alternator, 50 A
- Light, storage box mounted (one)
- Signaling/Warning horn

Engine/Power Train

- C6.4 with ACERT™ Technology
- 2300 m (7,500 ft) altitude capability without derate
- Air intake heater
- Automatic engine speed control with one touch low idle
- Equivalent to EU Stage II/EPA Tier 2 compliant
- Radial seal air filter
- Water separator in fuel line
- Waved fin radiator with space for cleaning
- 2 micron fuel filter

Operator Environment

- Adjustable armrest
- Ashtray with 24 volt lighter
- Beverage/cup holder
- Bi-Level air conditioner (automatic) with defroster
- Bolt-on Falling Object Guarding System (FOGS) capability
- Capability of installing two additional pedals
- Coat hook
- Front windshield glass split 70/30
- Light, interior
- Literature holder
- Monitor
 - Economy mode
 - Full time clock
 - Language display – Full color and graphical display
 - Machine condition, error code and tool mode setting
 - Start-up level check for hydraulic oil, engine oil and coolant
 - Warning information, filter/fluid change information and working hour
- Mounting for two stereo speakers (two locations)
- Neutral lever (lock out) for all controls
- Openable front windshield with assist device
- Openable skylight
- Pillar mounted upper windshield wiper and washer
- Pressurized cab
- Radio mounting (DIN size)
- Rear window, emergency exit
- Removable lower windshield with in-cab storage bracket
- Seat with integrated, adjustable console
- Seat belt, retractable (two inch width)
- Sliding upper door window
- Storage compartment suitable for lunch box
- Travel control pedals with removable hand levers
- Utility space for magazine
- Washable floor mat

Undercarriage

- Grease lubricated GLT2, resin seal
- Idler and center section track guiding

Other Standard Equipment

- Automatic swing parking brake
- Boom drift reducing valve
- Boom lowering device for back-up
- Counterweight with lifting eyes
- Door locks, cap locks and Caterpillar® one key security system
- Mirrors (frame-right, cab left)
- Regeneration circuit for boom and stick
- Reverse swing damping valve
- Stick drift reducing valve
- Two speed travel

Optional Equipment

Optional equipment may vary. Consult your Caterpillar dealer for details.

Front Linkage

Booms

- Reach 5.7 m (18 ft 7 in)
- Mass 5.2 m (17 ft 1 in)
- Super Long Reach 8.85 m (29 ft 1 in)
- Heavy-Duty Reach 5.7 m (18 ft 7 in)

Sticks

- R3.9B1 3.9 m (12 ft 8 in)
- R2.9B1 2.9 m (9 ft 7 in)
- R2.9B1 Heavy-Duty 2.9 m (9 ft 7 in)
- R2.5B1 2.5 m (8 ft 2 in)
- R2.5B1 Heavy-Duty 2.5 m (8 ft 2 in)
- M2.4CB2 2.4 m (7 ft 10 in)
- M1.9CB2 1.9 m (6 ft 3 in)
- Super long reach 6.82 m (20 ft 7 in)

Bucket Linkage

- B1 Family
- CB2 Family

Boom Lowering Control Device

Stick Lowering Check Valve

Electrical

Machine Security System (MSS)

Light, Boom – Right side

Lights, Cab mounted (2)

Power supply (12V-7 AMP)

Product Link (PL121SR/PL321SR)

Pump, Electric refueling

Travel Alarm

Guarding

Falling Object Guarding System (FOGS)

Front windshield guard

Full length, wire mesh

Heavy-duty bottom guards

Track guiding guards

Sprocket end, idler end guard

Two-piece full length (center guard removed)

Vandalism guards

Operator Environment

Hand control pattern changer (ISO-SAE)

Seat, high back with air suspension and heater

Third pedal, straight travel

Wiper, Lower windshield

Engine/Power Train

Prefilter, air

Starting, Cold weather package to -32°C (-26°F)

Two additional maintenance free batteries

High capacity starter motor

Heavy-duty cable

Jump-start receptacle

Water level indicator (Fuel)

Undercarriage

Standard undercarriage

Long undercarriage

Track shoes

600 mm (24 in) double or triple grouser

700 mm (28 in) double or triple grouser

800 mm (32 in) triple grouser

Heavy-duty rollers

Auxiliary Hydraulics

Hammer Circuit

For single function (1 way/2 pump) hydraulic tools

Thumb Circuit

For double function (2 way/1 pump) hydraulic tools

Tool Control System

For single or double function, (1 or 2 way, 1 or 2 pump) hydraulic tools

Joysticks with additional switches

Medium pressure circuit for tools requiring medium pressure

Common Circuit

For single/double (1 way/2 way, 1 or 2 pump)

Hydraulic pin grabber quick coupler and controller

Lines for booms and sticks

Work Tools

Wide offering of buckets, tips and sidecutters

320D/320D L Hydraulic Excavators

For more complete information on Cat products, dealer services,
and industry solutions, visit us on the web at www.cat.com

© 2007 Caterpillar
All Rights Reserved
Printed in U.S.A.

Materials and specifications are subject to change without notice.
Featured machines in photos may include additional equipment.
See your Caterpillar dealer for available options.

AEHQ5885 (5-07)

APD

CAT, CATERPILLAR, their respective logos, ACERT, "Caterpillar Yellow" and the
POWER EDGE trade dress, as well as corporate and product identity used herein,
are trademarks of Caterpillar and may not be used without permission.

CATERPILLAR®