

# TH330B

Telehandler



## Engine

Model	Caterpillar 3054E	
Gross Power (Basic)	74.5 kW	99 hp
Gross Power (Premium)	92 kW	120 hp

## Weights

Operating Weight	7020 kg	15,470 lb
------------------	---------	-----------

## Operating Specifications

Rated Load Capacity	3200 kg	7,000 lb
Maximum Lift Height	7200 mm	24 ft

# TH330B Telehandler

*Caterpillar® Telehandlers offer performance and versatility.*

---

## Operator Station

- ✓ Operators will feel relaxed and comfortable in the spacious, ergonomically designed cab. Considerable attention has been paid to control layout, making this cab an industry leader. **pg. 4**

---

## Ease of Operation

- ✓ Ease of operation was paramount in the design of the new TH330B. The single joystick, with its intuitive, modulated, hydraulic functions and the new Cat® electronic machine information display are designed to maximize operator efficiency. **pg. 5**

---

## Performance

- ✓ In its size class, the TH330B combines productivity, maneuverability and responsiveness to deliver smooth and stable performance on the job site. **pg. 6**

---

## Serviceability and Customer Support

- ✓ The lowest operating costs in the industry – setting new standards in serviceability. Caterpillar Dealer Services enables you to operate longer with lower costs, helped by significantly extended service intervals. **pg. 10**

*The TH330B is a highly versatile machine, designed to deliver maximum performance with traditional Cat reliability, durability and productivity in the toughest working conditions.*



---

### Power Train

- ✓ The TH330B is designed to perform in the toughest conditions. With its Cat 3054E engine, that's U.S. EPA Tier 2 compliant, and purpose designed Cat transmission and axles, you can depend on the TH330B to keep your job on schedule. **pg. 7**

---

### Versatility

- ✓ The TH330B is a very versatile machine. With its optional hydraulic quick coupler and extensive range of work tools, you can simply and efficiently get the job done. **pg. 8**

---

### Cost of Ownership

- ✓ Extended service intervals and the reduction in service parts give Cat the lowest operating costs in the industry. **pg. 9**



✓ *New Feature*

## Operator Station

*The operator station provides comfort and protection with excellent job site visibility and convenient, logical controls.*



**Intuitive Control Layout.** All day operator comfort and efficiency is ensured through our simple, logical control layout.



**Easy Access.** Cab entry and exit is both easy and convenient due to the well placed handholds and step.

**Operator Protection.** The machine provides full operator security with ROPS/FOPS protection.

**Seat.** A variety of seats are available, tailored to meet the requirements of the operator and applications.

**Electronic Machine Information Display.** Communicates essential technical data to facilitate easier machine operation.

**Excellent Visibility.** The B-Series cab has superb visibility due to the use of advanced virtual design techniques.

**Joystick.** The joystick is capable of three simultaneous boom functions making machine operation easy. All functions are fully modulated.

## Ease of Operation

*Ease of operation was paramount in the design of the new TH330B. The single joystick, with its intuitive, modulated, hydraulic functions, and the new Cat electronic machine information display are designed to maximize operator efficiency.*



*Fork Configuration*

**Joystick Control.** The joystick allows three simultaneous boom functions and incorporates unique slider switches.

The joystick also operates the auxiliary hydraulic function and allows the option of a second auxiliary service for the use of work tools that require more than one hydraulic service.

**Hydraulic System.** The Cat Electro Hydraulic system allows all three boom functions to be operated simultaneously and proportionally. This enables precise placing of loads in challenging applications.

Auxiliary hydraulic functions are available on the joystick to allow operators to utilize more complex work tools.

A continuous flow auxiliary hydraulic supply is also available for operating tools such as brooms that require continuous flow for long periods of time.

**Integrated System.** The Caterpillar exclusive integrated management system allows the engine, transmission and hydraulic systems to operate with maximum efficiency, control and productivity.

**Flow Sharing.** Three simultaneous hydraulic functions are achieved by:

- A load sensing variable displacement pump delivering flow on demand and ensuring that only the flow rate required is delivered, thus reducing fuel consumption and reducing heat generation.
- The post spool pressure compensating on the main implement valve ensures three function flow sharing even when valve demand exceeds pump output. Flow sharing is achieved regardless of loading on each circuit, making smooth boom movements easy even for inexperienced operators.

## Performance

*The TH330B delivers high performance to meet your specific job site needs.*



**Lift Height.** The TH330B can effectively and quickly place bricks and materials to a maximum height of 7.2 m (23.58 ft).

**Reach.** Job site obstacles present challenges demanding a machine to place loads at greater distances – the TH330B delivers.

**Maneuverability.** The TH330B offers excellent maneuverability, due to its tight turning circle and its three different steering modes.

The TH330B has 50 degree axle steering angle and no rear tail swing, allowing it to work productively and safely in confined areas.

**Steering Modes.** The TH330B offers three steering modes (two wheel, crab and circle steer) to allow an operator to easily position the machine. Steering modes are selected by a single three-position rocker switch. Steering position sensors are fitted as standard to all steering modes to be changed while moving.

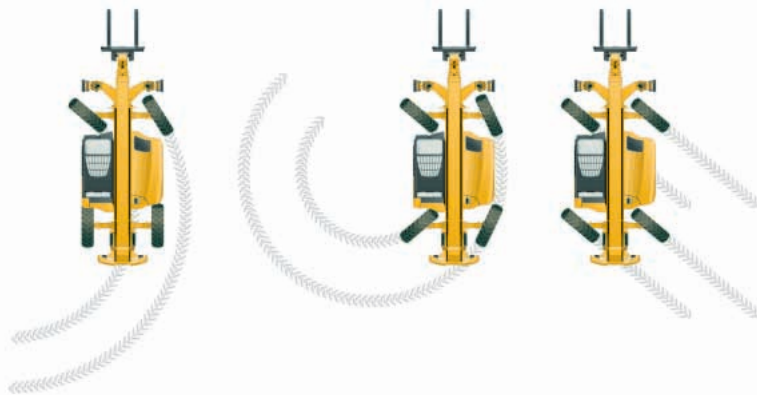

## Power Train

*Caterpillar engines, axles and transmissions give you the quality power train that you expect.*

**High Torque Rise Engine.** The Cat 3054E electronic engine is U.S. EPA Tier 2 compliant. While continuing to deliver maximum performance it features improved timing, reduced smoke and exceptional service improvements. For improved sound characteristics, a venturi tailpipe has been packaged inside the engine enclosure.

The cooling system has been designed to work in the most challenging conditions.

Electronic engines deliver:

- Improved low idle performance
- Improved fuel consumption
- Improved cold start
- Increased diagnostic and security capability

**Transmission.** The TH330B has a purpose designed Caterpillar four speed forward, three speed reverse powersyncro transmission.

**Axles.** The TH330B is fitted with Caterpillar planetary reduction axles.

For improved machine performance in difficult conditions, a differential lock is available (front axle).



## Versatility

*Redefine the traditional role of a Telehandler with the Cat TH330B.*



**Quick Coupler.** An IT interface is standard on the TH330B. For optimum versatility machines are equipped with a hydraulic quick coupler, allowing the operator to quickly and easily change non-hydraulic work tools without leaving the cab.

**Hydraulic Services.** Machines are equipped with Auxiliary Hydraulic services, allowing the use of hydraulically operated work tools. All B-Series Telehandlers are equipped with a single auxiliary hydraulic service and continuous hydraulic flow.

**Work Tools.** A wide range of work tools are available to meet most job site applications.

Caterpillar Telehandler Work Tools extend the versatility of the machine. Built for performance and durability, these work tools deliver high productivity, long life and excellent value.

- General Purpose Bucket (1.0 m<sup>3</sup>/1.3 yd<sup>3</sup>)
- Material Handling Bucket (1.5 m<sup>3</sup>/1.95 yd<sup>3</sup>)
- Multi Purpose Bucket (1.0 m<sup>3</sup>/1.3 yd<sup>3</sup>)
- Grapple Bucket (0.85 m<sup>3</sup>/1.1 yd<sup>3</sup>)
- Light Material Bucket (2.0 m<sup>3</sup>/2.6 yd<sup>3</sup>, 2.5 m<sup>3</sup>/3.25 yd<sup>3</sup>, 3.0 m<sup>3</sup>/3.9 yd<sup>3</sup>)
- Bale Handler
- Fixed Carriage
- Rotate Carriage
- Sideshift Carriage
- Wide Carriage
- Wide Rotate Carriage
- Pallet Forks
- Block Forks
- Lift Hook
- Truss Boom
- Self-tipping Hopper
- Material Handling Arm

Contact your Cat dealer for additional work tool options.

**Tow Hitches.** A manual rear tow hitch is available for off-highway towing as an option.



## Cost of Ownership

*Specifically designed to lower your owning and operating costs.*

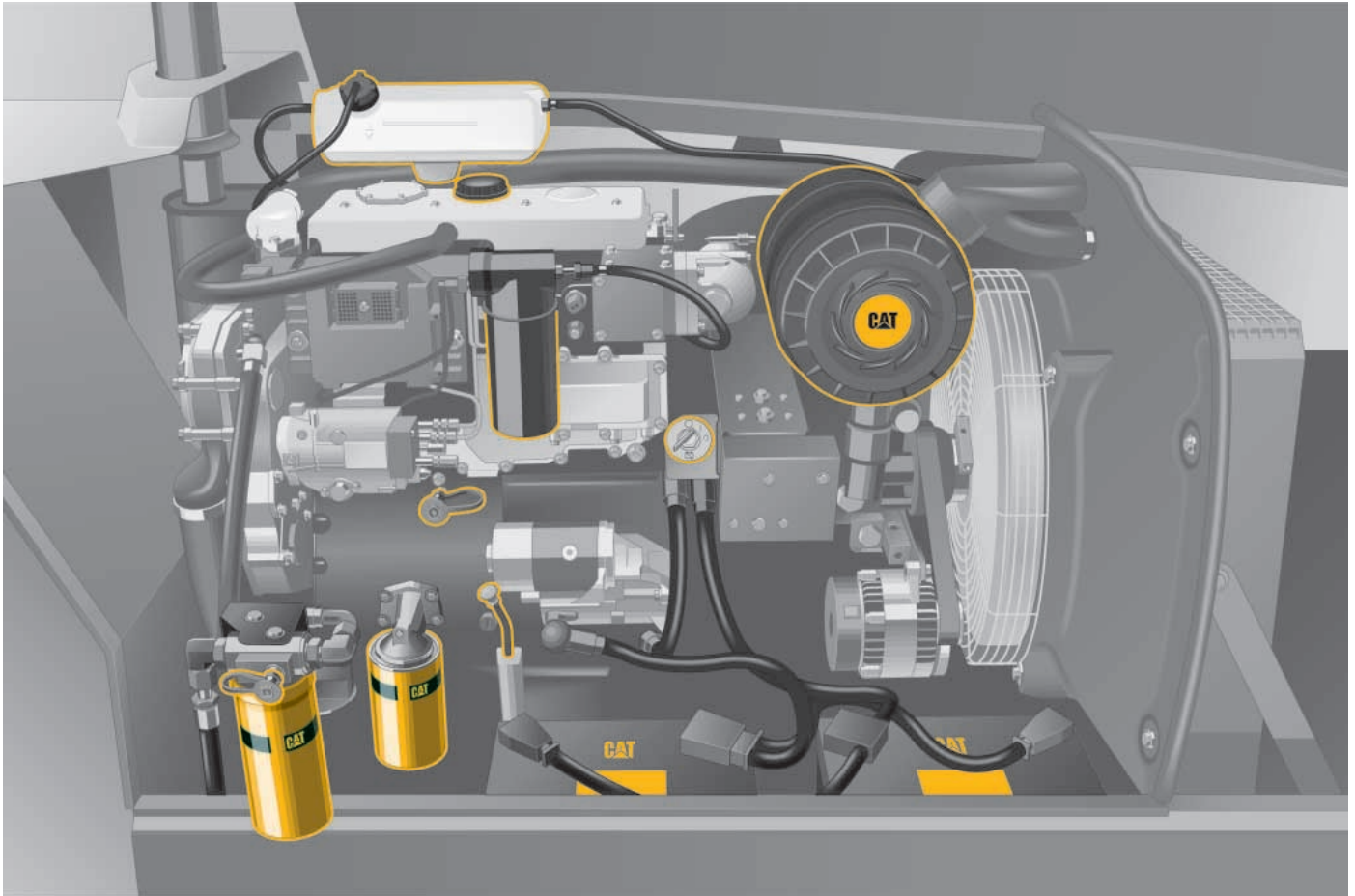

**Ease of Access.** Cost of ownership starts with ease of service. All Cat Telehandler service points are readily accessible and major components are easy to reach at ground level due to overall machine design.

**Daily Maintenance.** Routine daily maintenance is now reduced to checking fluid levels and a walkaround inspection.

**Service Intervals.** Engine oil, filter changes and routine lubrication are now only required every 500 hours.

**Reduced Componentry.** The combined hydraulic/transmission oil filter requires changing at 1,000 hours.

With the reduction in the number of filters and extended service intervals, operating costs are the lowest in the industry.

**Machine Security System.** Secure your investment with the Caterpillar Machine Security System (MSS), a programmable key system that provides optimum machine security for both fleet users and single owners.

- MSS disables machine by interacting with the machine's Electronic Control Modules (ECM)

- Keys fit all existing Cat machines (including machines without MSS)
- Each machine can store up to 50 key identifications
- Each key can be configured to operate a certain range of machines or enable operation for a certain period of time

## Serviceability and Customer Support

*Caterpillar Dealer Services enables you to operate longer with lower costs, helped by significantly extended service intervals.*



**Access.** All Cat Telehandler service points, including the combined transmission/hydraulic oil filter, are readily accessible and major components are easy to reach at ground level due to the overall machine design.

A cab mounted service point allows access to the fuel fill, hydraulic oil fill, washer bottle, fuse box and cab air filter for routine checks.

**Selection.** Make detailed comparisons before you buy. Your Cat Dealer can give you precise answers to your questions.

**Purchase.** Look at the value that the TH330B Telehandler will offer you. Consider all the flexible financing options your Cat Dealer offers as well as day to day operating costs.

**Operation.** Improving operating techniques can boost your profits. Your Cat Dealer has training literature and other ideas to help increase your productivity.

**Maintenance.** Repair options guarantee the cost of repairs up front. Diagnostic programs such as Scheduled Oil Sampling and Technical Analysis help you avoid unscheduled repairs.

**Replacement.** Repair, rebuild or replace? Your Cat Dealer can help you evaluate the cost involved so you can make the right choice.

**Product Support.** You will find high availability of parts at our Dealer parts counter. Cat Dealers utilize a worldwide computer network to find in-stock parts to minimize machine downtime.

Additionally, Caterpillar offers a line of genuine remanufactured components which can help lower repair costs.

**Easy Financing.** Your Cat Dealer can provide a financing package to meet your needs.

## Engine

Model	Caterpillar 3054E	
Gross Power (Basic)	74.5 kW	99 hp
Gross Power (Premium)	92 kW	120 hp
Net Power (Basic)	70.8 kW	94.9 hp
Net Power (Premium)	87.6 kW	117.5 hp
Maximum Torque (Basic)	410 N•m	303 lb ft
Maximum Torque (Premium)	450 N•m	333 lb ft
Bore	105 mm	4 in
Stroke	127 mm	5 in
Displacement	4.4 L	268 in <sup>3</sup>

- Engine is U.S. EPA Tier 2 compliant.
- Maximum Net Power shown is the net power available at the flywheel when the machine is equipped with fan, air cleaner, muffler and alternator.
- Max torque at 1,400 rpm.

## Weights

Operating Weight	7020 kg	15,470 lb
------------------	---------	-----------

## Operating Specifications

Rated Load Capacity	3200 kg	7,000 lb
Maximum Lift Height	7200 mm	24 ft
Maximum Forward Reach	3800 mm	12.5 ft
Load at Max Reach	1250 kg	2,750 lb
Top Travel Speed	40 kph	25 mph
Load at Max Height	2000 kg	4,400 lb
Load at Max Reach	1250 kg	2,750 lb
Reach at Bucket Dump (@ 45 Degrees)	1245 mm	49 in
Bucket Dump Height (@ 45 Degrees)	6066 mm	19.9 ft
Bucket Dump Angle at Full Height	37 Degrees	
Turning Radius over Tires	3340 mm	10.9 ft
Turning Radius over Forks	4530 mm	14.9 ft

## Dimensions

Height	2270 mm	7.4 ft
Width	2390 mm	7.85 ft
Wheelbase	3050 mm	10 ft
Length to Fork Face	4960 mm	16.27 ft
Ground Clearance	425 mm	16.7 in

## Hydraulic System

Maximum System Pressure	250 bar	3,626 psi
Maximum Pump Flow	113 L/min	30 gal/min
Pump Type	Variable Displacement Load Sensing Axial Piston Pump	
Auxiliary Hydraulic Supply – Intermittent	90 L/min	24 gal/min
Auxiliary Hydraulic Supply – Continuous	60 L/min	15.6 gal/min

## Service Refill Capacities

Fuel Tank	100 L	26.4 gal
Hydraulic Tank	59 L	15 gal
Additional Fuel Tank	50 L	13 gal

## Transmission Speeds

Forward – 1	7 kph	4 mph
Forward – 2	13 kph	8 mph
Forward – 3	22 kph	13 mph
Forward – 4	40 kph	25 mph
Reverse – 1	7 kph	4 mph
Reverse – 2	13 kph	8 mph
Reverse – 3	22 kph	13 mph

## Boom Performance

Boom Up	7 Seconds	
Boom Down	6 Seconds	
Tele In	6 Seconds	
Tele Out	6 Seconds	
Crowd Forward (dump)	3 Seconds	
Crowd Backward	3 Seconds	
Combined – Up and Out	11 Seconds	
Combined – Down and In	6 Seconds	
Boom Breakout Force	38.81 kN	8,723 lb
Bucket Breakout Force	64.63 kN	14,523 lb
Drawbar Pull (Basic)	80 kN	17,985 lb
Drawbar Pull (Premium)	95 kN	21,357 lb

# Dimensions

All dimensions are approximate.

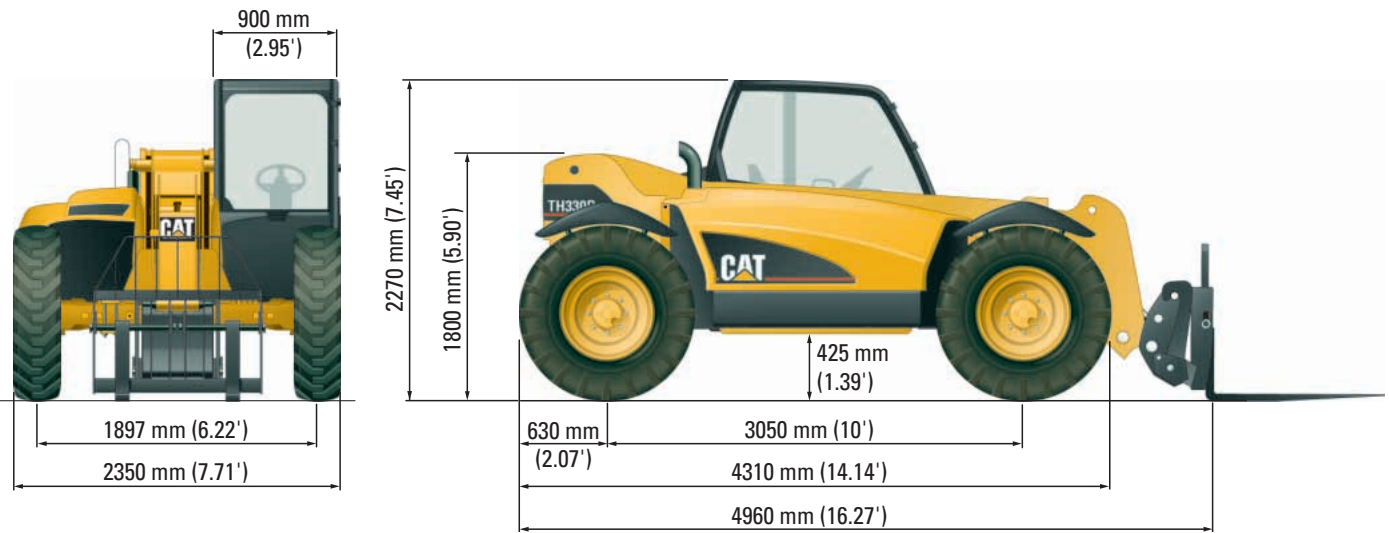

# Load Chart and Dimensions

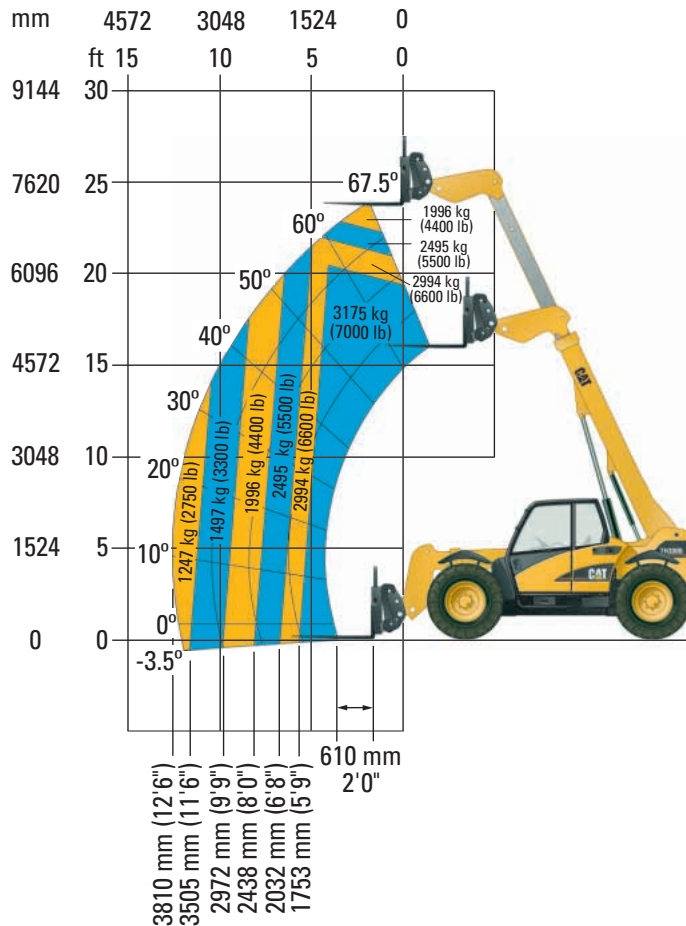

## Standard Equipment

*Standard equipment may vary. Consult your Caterpillar dealer for details.*

### TELESCOPIC BOOM

- Wear pads, non-metallic
- Lock valve on hydraulic cylinders
- Boom angle indicator
- Single auxiliary to the boom head

### ELECTRICAL

- Alternator, 105-amp
- Anti-restart key switch
- Battery, maintenance-free, 12 volt, 750 CCA with disconnect
- Horn
- Alarm, back up
- Electronic Control Module
- Power sockets, 12 volt internal and external
- Caterpillar Electronic Technician diagnostic connection

### OPERATOR STATION

- Canopy, ROPS/FOPS
- Joystick, electronic
- Adjustable joystick arm rest
- Low step, grab bars for easy entry
- 2-way adjustable vinyl suspension seat, seat belt, document pouch
- Steering wheel spinner knob
- Floor mat
- Right and left side rear view mirror
- Service door, cab air intake filter, fuel fill, hydraulic fill, level indicator, fuse panel and washer fill
- Instrument cluster with power train and system monitor, steering alignment indicator, fuel gauge, engine oil temperature gauge, engine water temperature gauge, hydraulic transmission temperature, SMU
- Cup holder
- Fixed steering column
- Boom lights

### POWER TRAIN

- Engine, Cat 3054E (U.S. EPA Tier 2 compliant)
- Air cleaner, dual element and filter condition indicator
- Thermal starting aid
- Water separator
- Transmission, Caterpillar 4 forward/3 reverse Powersyncro
- Direction change, single lever, column mounted
- Self aligned steering
- Spin-on filters: engine oil filter, hydraulic/transmission filter
- Axles, Caterpillar; planetary drive, full time mechanical 4-wheel drive, Integrated steer cylinders protected above axles, with steer sensors
- Steering, power assisted, enclosed oil disc brakes, front axle
- Parking brake, dry disc with transmission disconnect

### STRUCTURE

- Chassis, fixed frame
- Hydraulic quick coupler

### ANTIFREEZE

- Antifreeze, extended life  $-37^{\circ}\text{C}$  ( $-34^{\circ}\text{F}$ )

### TIRES

- 13.0-24 Cat Brand

### OTHER EQUIPMENT

- Integrated lift and tie down points
- Padlock on power module
- Retrieval point
- Standard Cat color paint
- Continuous flow hydraulics

## Optional Equipment

*Optional equipment may vary. Consult your Caterpillar dealer for details.*

### ELECTRICAL

- Light packages: boom lights, roading lights, cab lights
- Dual battery
- Engine heater block, 120V

### OPERATOR STATION

- Enclosed cab
- Air conditioning
- Heater
- Seats: cloth suspension, cloth air-suspension
- Headliner
- Sun visor
- Screen guard
- Additional mirror packages
- Rear wash/wipe
- Machine Security System (MSS)
- Beacon, magnetic mount
- Adjustable steering column
- Radio ready
- Adjustable joystick armrest

### POWER TRAIN

- Differential lock

### ANTI-FREEZE

- Anti-freeze, extended life  $-50^{\circ}\text{C}$  ( $-58^{\circ}\text{F}$ )

### TIRES

- 13.00-24 SGG Goodyear
- 15.5-25 Cat
- 13-24 Cat (Arnco ReSeal)
- 15.5-25 SGL Goodyear
- 15.5-25 Cat (Arnco ReSeal)
- 15.5 R25 XHA Michelin
- 13-24 Cat
- 440/70 R24 XM37 Michelin
- 500/70 R24 XM37 Michelin
- 13-24 Cat foam filled
- 15.5-25 Cat foam filled

### OTHER EQUIPMENT

- Additional fuel tank
- Fenders
- Lockable storage drawer
- Steering cylinder lock

### WORK TOOLS

- Carriage: standard, rotate, wide frame, wide frame (rotate), side-shift

### Forks:

- Pallet forks  $50 \times 100 \times 1220$  mm  
(2 in  $\times$  4 in  $\times$  48 in)
- Pallet forks  $50 \times 100 \times 1066$  mm  
(2 in  $\times$  4 in  $\times$  42 in)
- Block forks  $51 \times 51 \times 1220$  mm  
(2 in  $\times$  2 in  $\times$  48 in)
- Pallet forks  $51 \times 102 \times 1524$  mm  
(2 in  $\times$  4 in  $\times$  60 in)
- Extended Shank Forks  $50 \times 100 \times 1220$  mm  
(2 in  $\times$  4 in  $\times$  48 in)

### Buckets:

- General Purpose,  $1.0\text{ m}^3$  (1.3 yd<sup>3</sup>)
- Multi Purpose,  $1.0\text{ m}^3$  (1.3 yd<sup>3</sup>)
- Grapple,  $0.85\text{ m}^3$  (1.1 yd<sup>3</sup>)
- Material Handling,  $1.5\text{ m}^3$  (1.95 yd<sup>3</sup>)
- Light Material,  $2.0\text{ m}^3$  (2.6 yd<sup>3</sup>)
- $2.5\text{ m}^3$  (3.25 yd<sup>3</sup>)
- $3.0\text{ m}^3$  (3.90 yd<sup>3</sup>)

- Material Handling Arm
- Self-tipping Hopper,  $1.2\text{ m}^3$  (1.56 yd<sup>3</sup>)
- Lifting Hook
- Truss Boom
- Bale Handler

### OTHER ATTACHMENTS

- Tow hitches: hitch, manual rear-tow

---

## Notes

# TH330B Telehandler

For more complete information on Cat products, dealer services,  
and industry solutions, visit us on the web at [www.cat.com](http://www.cat.com)

© 2005 Caterpillar  
All Rights Reserved  
Printed in U.S.A.

Materials and specifications are subject to change without notice.  
Featured machines in photos may include additional equipment.  
See your Caterpillar dealer for available options.

AEHQ5546-02 (7-05)

Replaces AEHQ5546-01

CAT, CATERPILLAR, their respective logos and "Caterpillar Yellow," as well  
as corporate and product identity used herein, are trademarks  
of Caterpillar and may not be used without permission.

**CATERPILLAR**<sup>®</sup>