

135H

Motor Grader



Standard Version

Cat® 3116 turbocharged and aftercooled diesel engine
with Engine Power Management

Gears 4 - 8	116 kW	155 hp
Gears 1 - 3	101 kW	135 hp
Blade width	3658 mm	12 ft

Operating weights (approximate)
(Equipped with hydraulic side shift and tip, high profile
ROPS cab, differential with lock/unlock)

Operating weights (approximate)		
On front wheels	3756 kg	8274 lb
On rear wheels	9152 kg	20,158 lb
Total machine	12 908 kg	28,432 lb

Caterpillar® 135H Motor Grader

The 135H blends productivity and durability to give you the best return on your investment.

Power Train

Using advanced engine technology the 3116 engine offers exceptional lugging performance, fuel efficiency and engine power management. The power shift transmission features smooth, on-the-go shifting and electronic overspeed protection. To increase productivity, the direct drive transmission has eight forward speeds and six reverse speeds. **pg. 4-5**

Hydraulics

The load-sensing hydraulic system lowers power consumption and system heat. The control valves provide low lever effort, balanced flow and consistent implement control. **pg. 6**

Drawbar, Circle & Moldboard

The blade linkage design enhances moldboard positioning. A long wheel base allows the operator to obtain an aggressive moldboard angle for better material movement. The rugged construction of the drawbar, circle and moldboard, and use of replaceable wear inserts provide durability and minimize maintenance costs. **pg. 7**

Matched and balanced components.

The Cat® 3116 engine, direct-drive power shift transmission and load-sensing hydraulics are designed to work together to deliver top productivity in all applications.

Superior visibility, control layout and operating ease.

The operator is the single most important factor in maintaining high productivity throughout the work day. By offering a comfortable and convenient operator's station, Caterpillar helps operators achieve peak performance.



Operator's Station

Well-positioned blade linkage, a tapered engine hood and optional ROPS cab with large windows ensure a clear view in all directions. A roomy operator's station, low-effort controls and optional low sound level cab creates a more productive work environment. **pg. 8-9**

Serviceability

All service areas are easily accessible. A modular design permits easy removal of power train components for servicing. Diagnostic capability allows fast servicing of the transmission. **pg. 10**



Power Train

Matched Cat components deliver smooth, responsive performance and reliability.

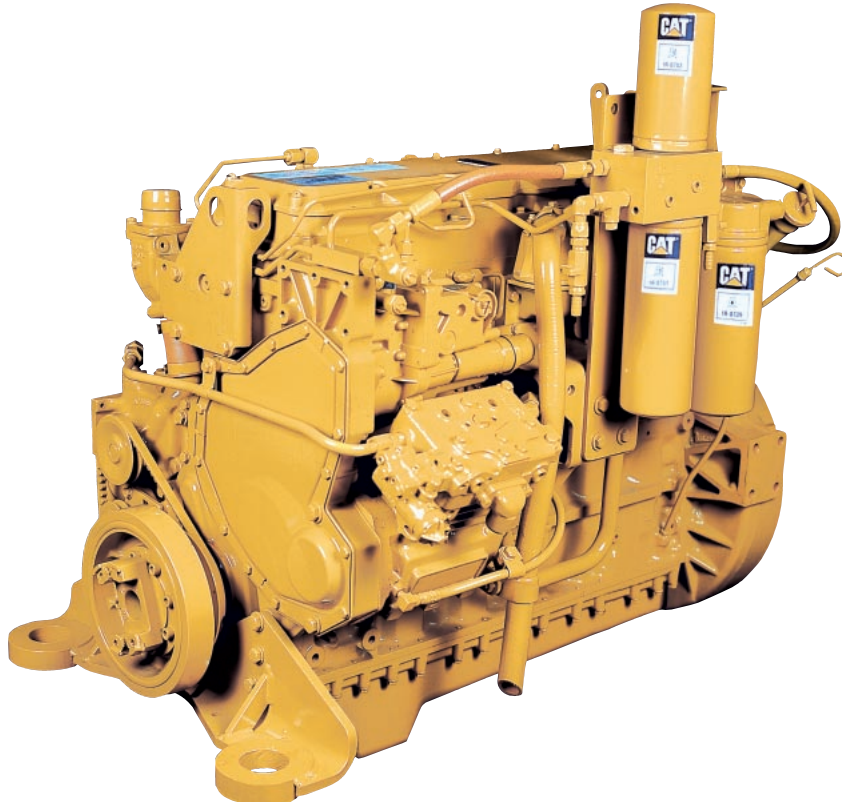

Cat 3116 engine. This modern, turbocharged and aftercooled, six-cylinder engine provides high performance in a fuel-efficient, low emissions package.

Superior lugging performance. High torque output and high torque rise make the 3116 engine very responsive. The engine's lugging capability allows it to pull through sudden, short-term increases in loads, reducing the need to downshift. As a result, the operator can maintain consistent, desirable working speeds, which means the work gets done faster.

Fuel efficiency. Unit injectors deliver very high fuel injection pressures to ensure proper mixing of fuel to air. This very high injection pressure, coupled with the precise metering and timing of the fuel injection, results in superior fuel efficiency and reduced emissions.

Extended engine life. A strong, rigid cylinder block, large-sized bearings and robust reciprocating parts are designed to withstand the rigors of high-pressure, low-emissions engines.

Dual secondary fuel filters provide an extra measure of assurance against engine and fuel system damage caused by fuel contaminants.

Engine power management delivers a full-rated net power of 116 kW (155 hp) in gears 4-8 forward. In lower gears, where the machine is traction-limited, engine horsepower is automatically reduced to 101 kW (135 hp). Engine power management works to lower fuel consumption as well as reduce tire slippage and wear in the lower gears.

Electronic overspeed protection helps prevent engine and transmission damage from premature downshifting and grade-induced overspeeding.

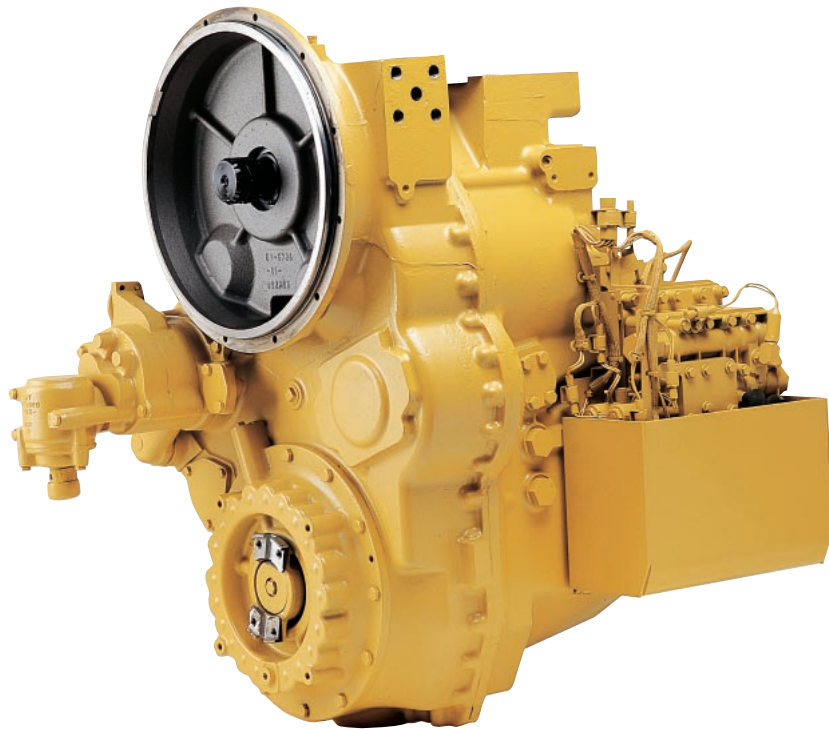

Power shift transmission. Caterpillar designs and builds transmissions specifically for Cat motor graders. The transmission provides on-the-go, full-power shifting as well as inching capability.

Direct drive delivers superior fuel efficiency and better feel of blade loads, material hardness and ground speed.

Gear selections. Eight forward speeds and six reverse speeds give the operator a wide operating range. With four gear selections below 9.7 km/h (6 mph), the operator can precisely match working speeds to job conditions for maximum productivity in earthmoving applications.

Electronic transmission control produces easy, smooth shifts, which enable the operator to maintain uniform surfaces if shifting is required. Smooth shifts also extend the life of the transmission by placing less stress on transmission clutches. A single lever controls direction, speed and the parking brake.

Inching capability. Low pedal effort and excellent modulation provide precise control of machine movements when using the inching pedal. This is especially important in finish grading or other close-quarter work where machine control is critical.

Dual air system supplies braking capacity to each side of the machine. This system ensures secondary braking capability in the event a failure occurs in a single brake line. The dual air system also has a large reserve for stalled-engine braking.

Oil-disc brakes. Caterpillar designs and builds multi-disc brakes that are completely sealed and adjustment-free. The brakes are oil-bathed, air-actuated and spring-released. They are located at each tandem wheel to eliminate braking loads on the power train and to reduce servicing time. The large brake surface provides dependable braking capability and extended life before rebuild.

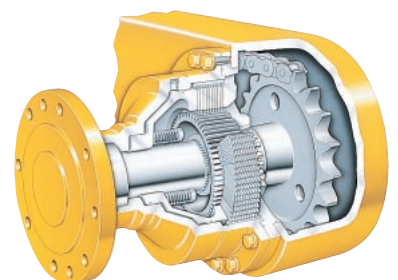

Hydraulics

Balanced hydraulics deliver consistent, precise and responsive control.

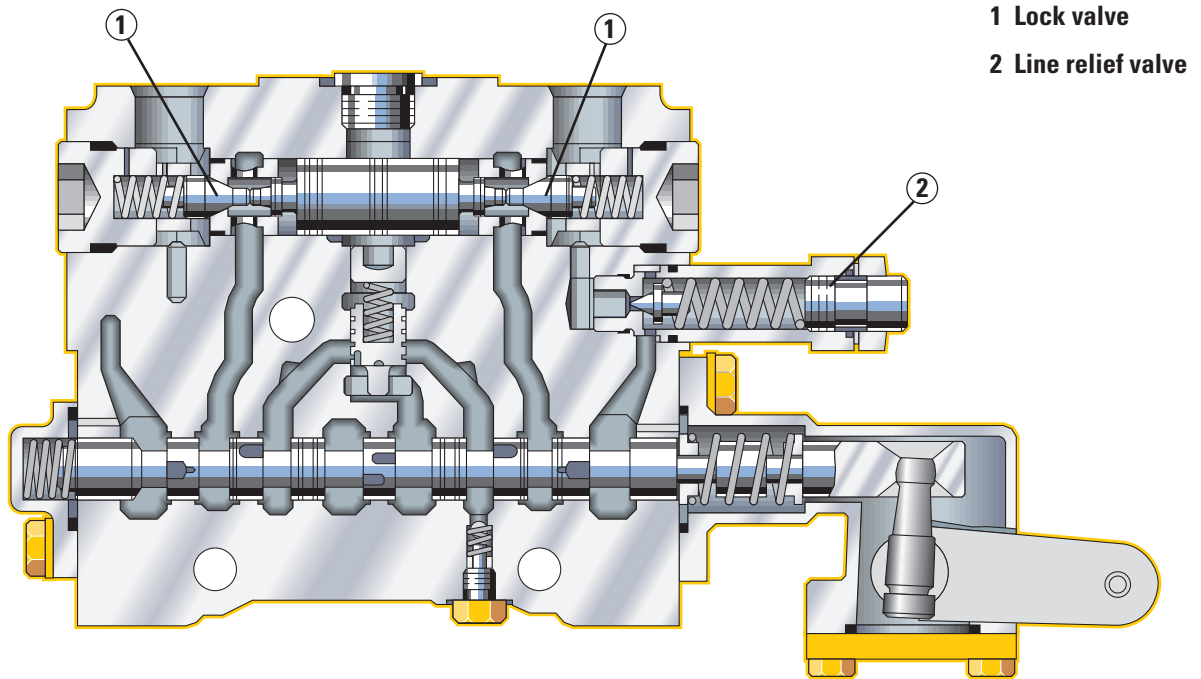

Power on demand. Normally, the variable displacement pump idles at near-zero output. When it senses a load requirement, the pump supplies flow and pressure to match the demand. The result is less hydraulic system heat and lower power consumption.

Implement control valves are designed and built by Caterpillar specifically for motor graders. They provide outstanding operator feel and predictable system response for unmatched implement control. To help maintain exact blade settings, lock valves are built into all control valves. Line relief valves are also incorporated into selected control valves to protect the cylinders from overpressurization.

Low operator effort. Implement controls are designed to reduce operator fatigue. They feature short lever throws and low effort in both directions. Properly spaced control levers and short lever throws allow the operator to use multiple controls with one hand.

Balanced flow. When the operator uses several controls at one time, flow is proportioned to ensure all implements can operate simultaneously. If hydraulic demand exceeds pump capacity, cylinder velocity will be reduced by the same ratio.

Large independent oil supply prevents cross-contamination and provides proper oil cooling, which means less heat build-up and extended component life.

Drawbar, Circle & Moldboard

Every component is designed for maximum productivity and durability.



Blade positioning. The blade linkage design enhances moldboard positioning. This blade linkage is most beneficial in ditch cutting and cleaning.

Blade angle. A long wheel base allows the operator to obtain an aggressive moldboard angle. This aggressive angle permits material to roll more freely along the blade, which reduces power requirements. This is particularly helpful in handling very dry materials, cohesive soils, snow and ice.

Rugged construction. The Y-frame drawbar is constructed of two solid beams. To resist wear, teeth are induction-hardened in the critical areas. The circle is secured to the drawbar by four support shoes.

Replaceable wear items. Tough, durable nylon composite wear inserts are located between the drawbar and circle, and between the support shoes and circle. This wear system helps keep components tight for fine grading and allows easy replacement. In addition to providing extended life, these inserts allow higher circle turning forces by reducing the friction between the circle and drawbar. Replaceable metallic wear inserts are used in the blade lift and centershift cylinder sockets, draftball surface and moldboard slide rail.

Circle drive slip clutch. Protects the drawbar, circle and moldboard from shock when the end of the blade encounters hidden objects. It also reduces the possibility of the grader making abrupt directional changes, further protecting the machine, operator and surroundings.

Operator's Station

Caterpillar sets the standard for comfort, convenience and visibility.





Excellent visibility helps improve operator confidence and productivity in all grader applications. The well-positioned blade linkage provides an unobstructed view of the moldboard and front tires. The operator has a clear view of the moldboard heel and tandem tires. A tapered engine hood provides good visibility to the rear of the machine.

Quiet cab. With optional engine compartment doors and the cab doors closed, interior sound level does not exceed 75 dB(A) when tested using SAE J919 standard or 77 dB(A) when tested using ISO 6394 standard. The quiet environment keeps the operator alert and focused.

More productive work environment. Low efforts on all pedals, hydraulic controls and the transmission shifter reduce operator strain and fatigue. Pedals are angled and raised off the cab floor to make them easy to reach. Extra leg and foot room create a spacious, operator station. The operator station includes built-in storage space for personal items such as a lunch box and cooler.

Optional heater arrangement. Creates a comfortable work environment for the operator. The heater arrangement includes four adjustable vents and is rated at 25,000 BTU/HR.

Comfort and convenience are designed into every feature:

- Engine start-stop switch enables the operator to start and stop engine with a simple key turn.
- Gauges are located on a panel directly in front of the operator.
- Controls and switches are located on the steering console and shift console Ñ all within easy reach.
- Rocker switches and transmission shifter are backlit for nighttime operation.
- The operator can adjust implement controls and steering wheel angle independently.
- Flat floor makes it easy to sweep and keep clean.
- Adjustable vinyl seat is optional.
- With optional ROPS cab:
 - door releases at ground level and inside the cab
 - adjustable cloth seat
 - well-positioned ashtray and lighter
 - easy access cupholder (also available with optional canopy)
 - optional 12-V power port for use with computers, cellular phones or other electronic equipment

Serviceability

Conveniently placed service points make routine maintenance quick and easy.

Easy access to service areas speeds up maintenance and ensures that routine service is performed on time:

- Large hinged doors are optional and provide easy access to the engine and radiator service points.
- Spin-on oil filters make changes quick and clean.
- Lubrication points for the articulation joint are remote-mounted.
- Disconnect switch and most service points are located on the left side, making them easy to access.
- Fuse panel is located at the base of the steering console. Its cover clearly identifies circuits and fuse sizes.
- Tandem oil check point is conveniently located between the wheels in the center of the tandem.
- Service meter is located on the left side of the steering console, giving the operator a clear view from the ground.
- Sampling ports are provided for drawing engine and hydraulic oil.
- Lockable battery box cover is easily removed without tools.

Power train components feature a modular design so you can remove the engine, transmission or parking brake independently for quick servicing.

Diagnostic capability offers fast servicing of the transmission. The transmission's electronic control module automatically records and saves any system faults for later analysis. S_YO_YS oil and coolant sampling valves provide a fast, convenient means of obtaining fluid samples and improve analysis reliability.



XT hose. Caterpillar designs and manufactures its own heavy-duty XT hose and installs it in all high-pressure circuits. Its resistance to abrasion, coupled with its exceptional strength and flexibility, help minimize maintenance and extend life.

O-ring face seals create a reliable seal and are used in all hydraulic circuits to minimize the possibility of oil leaks.

Radiator cleanout access. Removable covers on each side of the radiator guard provide access to the front of the radiator for cleanout with compressed air or pressure washer.

Extended Life Coolant (ELC) extends coolant life to 6000 hours. A single addition of ELC extender at 3000 hours is the only maintenance required.

Separate wiring harnesses connect all electrical components. This modular harness design provides simple disconnects for major machine repairs or rebuilds. The wires are also color-coded and numbered to speed up diagnosis and repairs. Sure-Seal connectors are made of weather-resistant materials that protect against moisture, corrosion and abrasion.

Environmentally Responsible Design

Caterpillar builds machines that help you create a better world.

The H Series motor graders respond to important environmental problems such as noise and air pollution. Today's machines run smoother, quieter and cleaner than ever before.

Quiet cab. With the optional sound-suppressed cab and engine compartment doors the interior sound level does not exceed 75 dB(A) when tested using SAE J919 standards or 77 dB(A) when tested using ISO 6394 standards. The resiliently-mounted engine and transmission result in less engine noise and vibration to the operator.

Quiet machine. With optional engine compartment doors, the drive-by exterior sound level will not exceed 81 dB(A) when tested at rated engine speed using SAE J88 standard test and 110 dB(A) when tested at rated engine speed using ISO 6393 standard test. This quiet operation enables the machine to work with minimal disturbance to the surrounding environment.

Low emissions. Engine performance has been maintained while reducing the amount of particulates and nitrogen oxides released into the air.

Dry machine. Lubricant fill points and filters are designed to minimize spillage. O-ring face seals, XT hose and Cat hydraulic cylinders protect against leaks.

Complete Customer Support

Caterpillar dealer services help you operate longer with lower costs.

Your Cat dealer offers a wide range of services that can be set up under a customer support agreement when you purchase your equipment. The dealer will help you choose a plan that can cover everything from machine and attachment selection to replacement, to help you get the best return on your investment.

Selection. Make detailed comparisons of the machines you are considering before you buy. How long do components last? What is the cost of preventive maintenance? What is the true cost of lost production? Your Cat dealer can give you precise answers to these questions.

Purchase. Look past initial price. Consider the financing options available as well as day-to-day operating costs and dealer services. Comparative resale value is another item to consider.

Operation. Improving operating techniques can boost your profits. Your Cat dealer has training videotapes, literature and other ideas to help you increase productivity.

Maintenance. More and more equipment buyers are planning for effective maintenance before buying equipment. Choose from your dealer's wide range of maintenance services at the time you purchase your machine. Repair option programs guarantee the cost of repairs up front. Diagnostic programs such as Scheduled Oil Sampling and Technical Analysis help you avoid unscheduled repairs.

Product support. You will find nearly all parts at our dealer parts counter. In the rare case when we don't have a part in stock, we will get it to you fast.

Replacement. Repair, rebuild or replace? Your Cat dealer can help you evaluate the costs involved so you can make the right choice.

Engine

Four-stroke cycle, six cylinder Caterpillar 3116 turbocharged and aftercooled diesel engine with engine power management (EPM).

Power ratings for gears 4-8 forward and 3-6 reverse.

Ratings at 2000 rpm*	kW	hp
Gross power	124	166

The following ratings apply at 2000 rpm when tested under the specified standard conditions for the specified standard:

Net power	kW	hp
Caterpillar	116	155
ISO 9249	116	155
SAE J1349	116	155
EEC 80/1269	116	155

Peak torque (net) @ 1400 rpm	719 Nm	529 lb-ft
Torque rise	30%	

Dimensions

Bore	105 mm	4.13 in
Stroke	127 mm	5.00 in
Displacement	6.6 liters	403 cu in

Power ratings for gears 1-3 forward and 1-2 reverse.

Ratings at 2000 rpm*	kW	hp
Gross power	109	146

The following ratings apply at 2000 rpm when tested under the specified standard conditions for the specified standard:

Net power	kW	hp
Caterpillar	101	135
ISO 9249	101	135
SAE J1349	101	135
EEC 80/1269	101	135

Peak torque (net) @ 1400 rpm	639 Nm	472 lb-ft
Torque rise	33%	

*Power rating conditions

- based on standard air conditions of 25°C (77°F) and 99 kPA (29.32 in Hg) dry barometer
- used 35° API gravity fuel having an LHV of 42 780 kJ/kg (18,390 Btu/lb) when used at 30°C (86°F) [ref. a fuel density of 838.9 g/L (7.001 lb/U.S. gal)]
- net power advertised is the power available at the flywheel when engine is equipped with fan, air cleaner, muffler and alternator
- no derating required up to 3750 m (12,304 ft) altitude

Features

- direct injection fuel system with individual adjustment-free unit injectors
- 3-ring aluminum alloy pistons
- heat resistant stellite-faced valves
- forged steel connecting rods
- one-piece cylinder head designed with cast intake manifold
- cast cylinder block with oil cooler cavity cast into block
- induction-hardened, forged crankshaft
- direct electric 24-V starting and charging system
- two 12-V, 100 amp-hour, 750 CCA, maintenance-free batteries
- 35-amp alternator
- plate-type, water-cooled oil cooler
- vertical-flow, steel-fin, tube-type radiator
- dry-type, radial-seal air cleaner with primary and secondary elements
- dual fuel filters
- resiliently mounted to rear frame

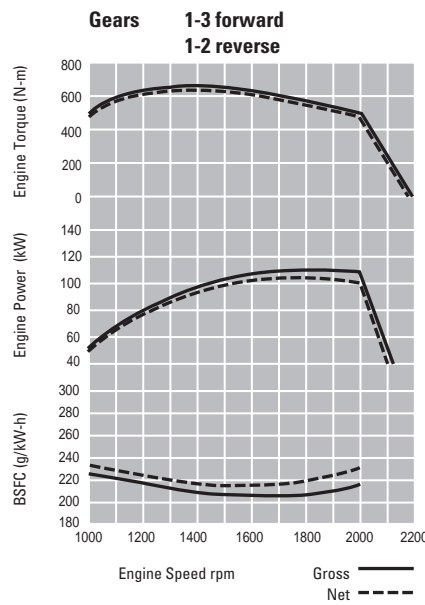
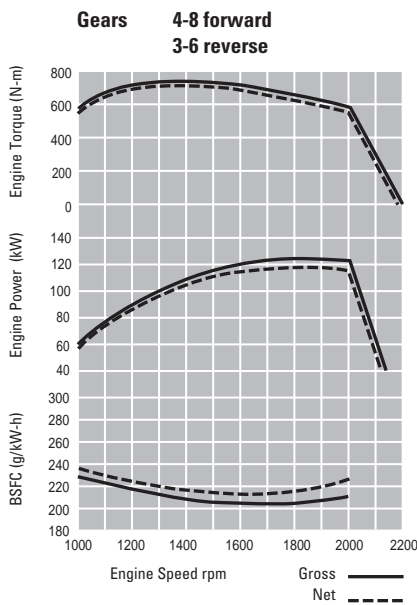

Hydraulic System

Proportional priority pressure compensated system.

Output at 2000 rpm and 24 150 kPa (3500 psi)	148 liters/min	39.0 gpm
With optional high capacity pump output at 2000 rpm and 24 150 kPa (3500 psi)	190 liters/min	49.5 gpm
Standby pressure	3100 kPa	450 psi
Maximum system pressure	24 150 kPa	3500 psi

Pump features

- load sensing, pressure compensating, variable-displacement piston pump
- low standby pressure
- pump supplies only flow and pressure required to move implements plus 2100 kPa (300 psi) margin pressure

Control features

- six, closed-center control valves standard:
 - ↳ right blade lift
 - ↳ left blade lift
 - ↳ circle drive
 - ↳ centershift
 - ↳ front wheel lean
 - ↳ articulation
- low effort, short throw controls
- controls spaced to allow use of several controls at once

- lock valves built into all control valves
- line relief valves for the blade lift circuits are incorporated into the control valves
- if flow requirements exceed pump output, control valves proportion flow to each implement circuit

Other features

- steering circuit given priority over implement circuits
- heavy duty XT hose
- reliable couplings with O-ring face seals
- full-flow filter
- high capacity pump beneficial when using multiple functions simultaneously

Service Refill Capacities

	liters	gallons
Fuel tank	284	75.0
Cooling system	40	10.4
Crankcase	23	6.0
Transmission, differential and final drives	47	12.2
Tandem housing (each)	61	15.9
Hydraulic system	61	16.0
Hydraulic tank	38	9.9
Circle drive housing	7	1.8
Front wheel spindle bearing housing	0.5	0.13

Steering

Two-cylinder, hydraulic steering with hand metering unit.

Dimensions

Minimum turning radius (outside front tires)*	7.2 m	23' 8"
Steering range	50°	Left/Right
Articulation angle	20°	Left/Right

* Using front wheel steering, frame articulation and with optional differential unlocked.

Features

- large steer stops and steering relief valve help prevent damage when object is hit during full turn
- consistent steering response to the left and right

Transmission

Direct drive, power shift transmission with eight speeds forward.

Maximum travel speeds (at rated rpm with standard 13.00-24 tires)

		km/h	mph
Forward	1	3.6	2.3
	2	4.9	3.1
	3	7.2	4.5
	4	9.9	6.2
	5	15.4	9.6
	6	20.9	13.0
	7	28.8	17.9
	8	41.9	26.0
Reverse	1	2.9	1.8
	2	5.4	3.3
	3	7.8	4.9
	4	12.2	7.6
	5	23.0	14.3
	6	33.1	20.6

Features

- electronic shift control
- electronically controlled overspeed protection
- single lever controls direction, speed and parking brake
- inching pedal
- low efforts on shift lever and inching pedal
- internal parking brake serviceable without removing transmission
- diagnostic connector for easy troubleshooting
- resiliently mounted to rear frame

Frame

Flanged, box section design.

Dimensions

Front frame	mm	in
-------------	----	----

Top and bottom plates

Width	280	11
Thickness	22	0.9

Side plates

Width	236	9.3
Thickness	10	0.4

Linear weights

Front frame	kg/m	lb/ft
-------------	------	-------

Minimum	134	90
Maximum	172	115

Section modulus

Front frame	cu cm	cu in
-------------	-------	-------

Minimum	1619	99
Maximum	3681	225

Features

- single piece top and bottom plates run from bolster to articulation joint
- rear frame has two box-sectioned channels integral with fully welded differential case

Front Axle

Live spindle design.

Dimensions

Front axle

Ground clearance	608 mm	23.9"
Front wheel lean		18 _i
Oscillation angle		32 _i

Features

- allows use of large outboard bearings for high load-carrying capability of the wheel assembly
- wheel spindle rotates inside sealed compartment
- bearings bathed in oil

Tandems

Dimensions

	mm	in
--	----	----

Height	502	19.8
Width	172	6.8

Sidewall thickness

Inner	14	0.55
Outer	16	0.63
Drive chain pitch	44.5	1.75
Wheel axle spacing	1510	59.5
Tandem oscillation	15 _i Forward 25 _i Reverse	

Brakes

Meets the following standards: SAE J1473 OCT 90 and ISO 3450-1996.

Service brake features

- air actuated, oil-disc brakes located in each of the four wheel spindle housings
- sealed and adjustment-free
- lubricated and cooled by tandem housing oil
- 18 604 cm² (2884 in²) of total braking surface

Parking brake features

- multiple oil-disc unit
- located in the transmission on the output shaft
- manually actuated
- spring engaged, air pressure released
- engaged parking brake neutralizes transmission
- 1916 cm² (297 in²) of total brake surface area

Secondary brake features

- separate circuits to right and left tandems
- malfunction of one circuit still leaves machine with at least half of original braking capacities
- dual chamber air tank provides air to actuate brakes five times after engine and compressor stop
- in the event of total braking loss, the spring-actuated parking/emergency brake can be used to lock the wheels on any surface

Tires and Rims

Tires	Rims	Type
13.00-24	9" x 24" 10" x 24"	SP MP
14.00-24	9" x 24" 10" x 24"	SP MP
15.5-25	13" x 25"	SP
17.5-25	13" x 25" 14" x 25"	SP MP

SP = Single-Piece Rim

MP = Multi-Piece Rim

Notes: An assortment of bias and radial tire models are available from various manufacturers offering different sizes, strength indexes and industry types. Depending on the weight of additional equipment, the machine load may exceed certain tire capabilities. Caterpillar recommends that you carefully evaluate all conditions before selecting a tire model.

Drawbar

Solid steel bars fabricated into Y-frame design.

Dimensions

Drawbar frame	mm	in
Height	127	5
Thickness	76	3

Features

- four shoes support circle
- all shoes have vertical and horizontal adjustment
- nine replaceable nylon composite wear strips between circle and drawbar
- four replaceable nylon composite wear strips between the circle and support shoes

Circle

Circle is fabricated T-section.

Dimensions

Circle	mm	in
Circle diameter	1530	60.2
Blade beam thickness	30	1.2

Features

- 64 uniformly spaced, flame-cut teeth
- teeth surfaces hardened on front 240 μ of circle
- hydraulically driven, circle drive motor
- 360 \circ circle rotation

Moldboard

Fabricated from wear-resistant, high-carbon steel.

Dimensions

Moldboard	mm	in
Length	3658	144
Height	610	24
Thickness	22	0.87
Arc radius	413	16.25
Throat clearance	120	4.7

Cutting Edge	mm	in
Width	152	6
Thickness	16	0.63

Endbit	mm	in
Width	152	6
Thickness	16	0.63

Features

- cutting edge and endbit are Caterpillar through-hardened, curved DH-2 steel
- 16 mm (.63") diameter bolts
- three sideshift mounting locations for optional 4267 mm (14') moldboard

Optional hydraulic sideshift

- heat-treated sideshift rails
- replaceable metallic wear inserts

Blade Range

Full range of blade positioning.

		3-Position Link Bar		7-Position Link Bar		
		mm	in	mm	in	
Circle centershift	Right	460	18.1	628	24.7	
	Left	690	27.2	625	24.6	
Moldboard sideshift	(mechanical)	Right	660	26.0	660	26.0
		Left	660	26.0	660	26.0
	(hydraulic)	Right	660	26.0	660	26.0
		Left	524	20.6	524	20.6
Maximum shoulder reach outside of tires	(mechanical)	Right	1760	69.3	1912	75.3
		Left	1976	77.8	1976	77.8
	(hydraulic)	Right	1760	69.3	1912	75.3
		Left	1840	72.4	1840	72.4
Maximum lift above ground		457	18.0	457	18.0	
Maximum depth of cut		728	28.7	775	30.5	
Maximum blade position angle		65 \circ Both Sides		90 \circ Both Sides		
Blade tip range	(mechanical and hydraulic)	40 \circ Forward		40 \circ Forward		
		5 \circ Backward		5 \circ Backward		

Features

- steep ditch cutting angles possible
- aggressive blade carrying angles possible
- 1.5:1 and 2:1 back slope can be done without putting front tire on slope with optional 7-position link bar

Add 305 mm (12") for maximum right or left moldboard sideshift when using optional 4267 mm (14') blade.

With the machine in the crab position, add 940 mm (37") to maximum right or left moldboard sideshift.

Dimensions

All dimensions are approximate.

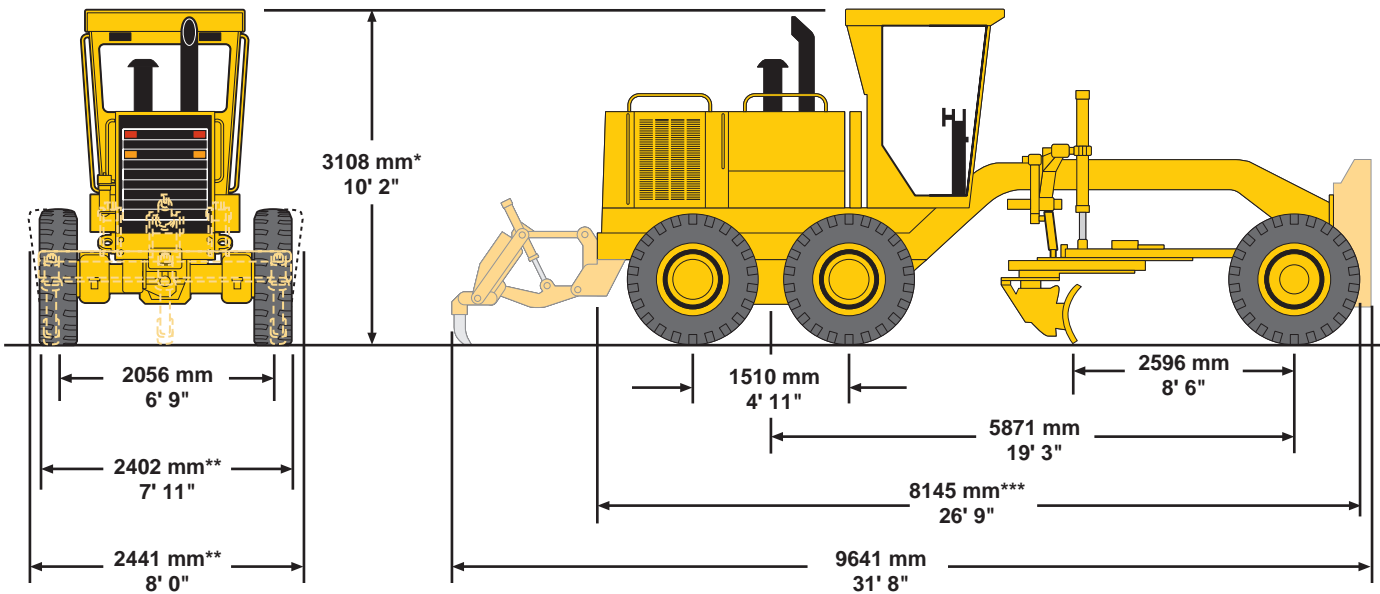

Operating weights (approximate)

on front wheels	3462 kg	7632 lb
on rear wheels	8326 kg	18,357 lb
total machine	11 788 kg	25,989 lb

Operating weights based on standard machine configuration with 13.00-24 10PR (G-2) tires, full fuel tank, coolant, lubricants and operator.

Operating weights (approximate)

(Equipped with hydraulic side shift and tip, high profile ROPS cab and differential with lock/unlock)

on front wheels	3756 kg	8,274 lb
on rear wheels	9152 kg	20,158 lb
total machine	12 908 kg	28,432 lb

* with optional low-profile cab;

add 225 mm (8.9") for optional full height cab or canopy

** add 267 mm (10.5") for optional 17.5-25 tires

*** add 235 mm (9.3") for front pushplate

add 117 mm (4.6") for rear hitch or

add 1261 mm (4' 2") for rear-mounted ripper

Note: Height without ROPS, exhaust, or other easily removed encumbrances 2.95 m (9'7").

Scarifier and Ripper

Type	V-Type-Scarifier (mid-mounted)		Ripper (rear-mounted)	
Working width	1184 mm	46.6"	2300 mm	91"
Scarifying depth, maximum	292 mm	11.5"	Ñ	
Scarifier shank holders:				
number	11		Ñ	
spacing	116 mm	4.6"	Ñ	
Ripping depth, maximum	Ñ		262 mm	10.3"
Ripper shank holders:				
number	Ñ		5	
spacing	Ñ		533 mm	21"
Increase in machine length, beam raised	Ñ		688 mm	27.1"
Penetration force*	Ñ		4343 kg	9566 lb
Pryout force	Ñ		2279 kg	5020 lb

*Varies with machine configuration.

Operator Platform

Features

- adjustable control console
- back-lit rocker switches
- engine key start/shut-off switch
- floormat
- fuse panel in steering control console
- gauges located on the front panel
 - articulation
 - brake air pressure, two
 - engine coolant temperature
 - engine oil pressure
 - voltmeter
- hand throttle
- horn switch
- hydraulic power steering
- hydraulic implement controls
 - articulation
 - center shift
 - circle drive
 - left blade lift
 - right blade lift
 - wheel lean

- indicator lights
 - centershift pin disengaged
 - parking brake engaged
 - service brake air pressure low
 - transmission diagnostics
 - transmission fault
- low-effort suspended foot pedals
 - accelerator
 - decelerator
 - inching pedal
 - service brakes
- lunch box area
- seat, vinyl, static
- seat belt
- service hour meter
- tilt adjustable steering wheel
- transmission control Ñ single lever controls direction, speed and parking brake
- transmission diagnostic connector
- platform guard group Ñ front and rear

Optional ROPS cab features

- ashtray and 24-V lighter
- cloth covered adjustable seat with retractable seat belt
- cupholder
- front windshield wiper and washer
- ground level door release
- high profile sound suppressed cab
- rear view mirror
- 10; slanted rear window
- sweep-out cab floor
- optional front and rear defroster fans
- optional heater system with adjustable vents and three-speed fan
- optional lower opening front windows
- optional rear wiper and washer
- optional 12-V power port

ROPS/FOPS features

- ROPS (Rollover Protective Structure) meets the following criteria:
 - SAE J396
 - SAE J1040 MAY94
 - ISO 3471-1994
- also meets the following FOPS (Falling Object Protective Structure) criteria:
 - SAE J231 JAN81
 - ISO 3449-1992

Standard Equipment

Consult your Caterpillar dealer for details.

Electrical

Alternator, 35-amp, sealed
Batteries, two maintenance-free,
750 CCA
Battery box cover, lockable
Electrical system, 24-V
Horn, electric
Lights, stop and tail
Main disconnect switch
Motor, starting

Operator Environment

Accelerator-decelerator
Alarm, low brake air pressure
Control console, adjustable
Gauge panel
- articulation
- brake air pressure, two
- engine oil pressure
- engine coolant temperature
- voltmeter
Guard rails, operator station
Hydraulic controls, load-sensing
- articulation
- blade lift, right and left
- centershift
- circle drive
- front wheel lean
Indicator lights
- centershift pin
- low air pressure
- parking brake
- transmission diagnostics
- transmission fault

Key start/stop switch
Power steering, hydraulic
Seat, vinyl covered, static
Seat belt, 3 in
Service hour, meter
Steering wheel, tilt, adjustable
Storage area, cooler/lunch box
Throttle, hand

Power Train

Air cleaner, dry type, radial seal with
service indicator and automatic
dust ejector
Blower fan
Brakes, oil disc, four-wheel,
air actuated
Engine, 3116 DITA diesel with
engine power management,
low emissions
Muffler, under hood
Parking brake, multi-disc, sealed and
oil-cooled
Prescreener
Priming pump, fuel
Tandem drive
Transmission, 8-speed forward and
6-speed reverse power shift, direct
drive with electronic shift control
and overspeed protection

Other Standard Equipment

Bumper, rear
Circle drive slip clutch
Cutting edges, 152 mm x 16 mm
(6" x 5/8") curved DH-2 steel
Drawbar, four shoe with replaceable
nylon composite wear strips
End bits, 16 mm (5/8") DH-2 steel
Frame, articulated, with safety lock
Fuel tank, 284-liter (75-gallon), with
dipstick
Link bar, 3-position
Locking caps with padlocks for
hydraulic tank, radiator access
cover and fuel tank
Moldboard, 3658 mm x 610 mm x
22 mm (12' x 24" x 7/8") with
mechanical sideshift and tip
Rims, refer to Tires and Rims
section, page 14
Steps, rubber belted
Tires, refer to Tires and Rims
section, page 14
Tool box with padlock

Optional Equipment

With approximate change in operating weight.

	kg	lb		kg	lb
Alternator, 50-amp	7	15	Instrument panel cover	5	10
Alarm, back up	3	6	Lighting system:		
Blade, 3658 mm x 610 mm x 22 mm (12' x 24" x 7/8") with hydraulic sideshift	191	421	bar mounted lights, directional and headlights	13	28
Blade, 3658 mm x 610 mm x 22 mm (12' x 24" x 7/8") with hydraulic sideshift and tip	288	635	work lights, front	5	10
Blade, 4267 mm x 610 mm x 22 mm (14' x 24" x 7/8") with mechanical sideshift and tip	75	166	work lights, front and rear	6	13
Blade, 4267 mm x 610 mm x 22 mm (14' x 24" x 7/8") with hydraulic sideshift	266	587	warning light, cab-mounted	3	6
Blade, 4267 mm x 610 mm x 22 mm (14' x 24" x 7/8") with hydraulic sideshift and tip	363	801	Link bar, 7-position extended reach	21	46
Bumper with hitch, rear	33	72	Mirrors, dual, inside-mounted	Ñ	Ñ
Cab, ROPS, high profile, sound suppressed	748	1650	Mirrors, outside-mounted	8	18
Cab, ROPS, low profile, sound suppressed	671	1480	Power port, 12-V	2	5
Canopy, ROPS, high profile, with rear wall and window	630	1390	Pump, hydraulic pump, high capacity	5	10
Cutting edges, 203 mm x 19 mm (8" x 3/4")	20	44	Push plate, front-mounted	907	2000
Endbits, overlay, reversible	11	24	Rims, refer to Tires and Rims section, page 14		
Fan, defroster, front and rear	4	8	Ripper, rear-mounted, hydraulic	612	1350
Differential, lock-unlock	41	90	Ripper, shank/tooth, one	12	26
Doors, engine compartment, locking	101	223	Scarifier, front-mounted, V-type	845	1862
Ether starting aid	0	1	Seat, vinyl, adjustable	14	30
Extensions, blade, 610 mm (2')	113	250	Sunshade, rear window	3	7
Guard, transmission	98	215	Tires, refer to Tires and Rims section, page 14		
Heater, without pressurizer	14	30	Windows, lower front, opening	3	6
Horn, air	5	10	Windows, sliding side	4	8
			Wiper and washer, rear	7	16

Hydraulic arrangements with one or more additional hydraulic valves are available for blade sideshift, blade tip, front scarifier, dozer and ripper

135H Motor Grader

AEHQ5275 (11-98)
(Replaces AEHQ5124-01)

www.CAT.com
© 1998 Caterpillar
Printed in U.S.A.

Materials and specifications are subject to change without notice.
Featured machines in photos may include additional equipment.
See your Caterpillar dealer for available options.

