



C15 ACERT™
Industrial Engine
Tier 3/Stage IIIA
433 bkW/580 bhp @ 2100 rpm

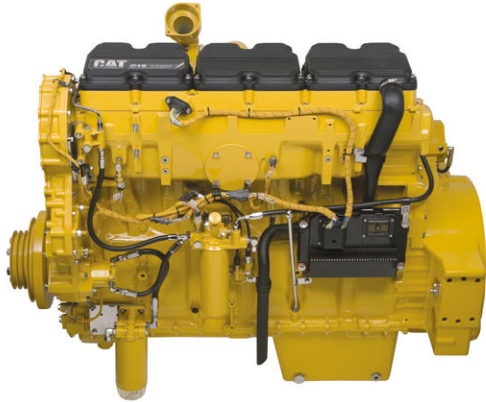

Image shown may not reflect actual engine

CAT® ENGINE SPECIFICATIONS

I-6, 4-Stroke-Cycle Diesel

Bore.....	137.2 mm (5.4 in)
Stroke.....	171.4 mm (6.75 in)
Displacement.....	15.2 L (927.56 in ³)
Aspiration.....	Turbocharged Aftercooled
Compression Ratio.....	18.0:1
Rotation (from flywheel end).....	Counterclockwise
Weight, Net Dry (approximate kg. lb)..	1469 kg (3239 lb)

FEATURES

Emissions

Meets U.S. EPA Tier 3, EU Stage IIIA emission requirements.

Worldwide Supplier Capability

Caterpillar
- Casts engine blocks, heads, cylinder liners, and flywheel housings
- Machines critical components
- Assembles complete engine
- Factory-designed systems built at Caterpillar ISO 9001:2000 certified facilities
Ownership of these manufacturing processes enables Caterpillar to produce high quality, dependable product.

Testing

Prototype testing on every model:
- proves computer design
- verifies system torsional stability
- functionality tests every model

Every Caterpillar engine is dynamometer tested under full load to ensure proper engine performance.

Full Range of Attachments

Wide range of bolt-on system expansion attachments, factory designed and tested.

Unmatched Product Support Offered Through Worldwide Caterpillar Dealer Network

More than 1,800 dealer outlets
Caterpillar factory-trained dealer technicians service every aspect of your industrial engine
99.7% of parts orders filled within 24 hours worldwide
Caterpillar parts and labor warranty
Preventive maintenance agreements available for repair before failure options

Scheduled Oil Sampling program matches your oil sample against Caterpillar set standards to determine:

- internal engine component condition
- presence of unwanted fluids
- presence of combustion by-products

Web Site

For all your industrial power requirements, visit www.cat-industrial.com.



C15 ACERT™ Industrial Engine

Tier 3/Stage IIIA

433 bkW/580 bhp @ 2100 rpm

STANDARD ENGINE EQUIPMENT

Air Inlet System

ATAAC
Turbocharged

Control System

Electronic governing
PTO speed control
Programmable ratings
Cold mode start strategy
Automatic altitude compensation
Power compensation for fuel temperature
Programmable low and high idle and total engine limit
Electronic diagnostics and fault logging
Engine monitoring system
J1939 Broadcast (diagnostic and engine status)
ADEM™ A4

Cooling System

Thermostats and housing, vertical outlet
Jacket water pump, centrifugal
Water pump, inlet

Exhaust System

Exhaust manifold, dry
Optional exhaust outlet

Flywheels and Flywheel Housing

SAE No. 1 Flywheel housing

Fuel System

MEUI injection
Fuel filter, secondary (2 micron high performance)
Fuel transfer pump
Fuel priming pump
ACERT™ Technology

Lube System

Crankcase breather
Oil cooler
Oil filler
Oil filter
Oil pan front sump
Oil dipstick
Oil pump (gear driven)

General

Paint, Caterpillar Yellow
Vibration damper
Lifting eyes



C15 ACERT™ Industrial Engine

Tier 3/Stage IIIA

433 bkW/580 bhp @ 2100 rpm

PERFORMANCE CURVES

IND - D - DM7771-01

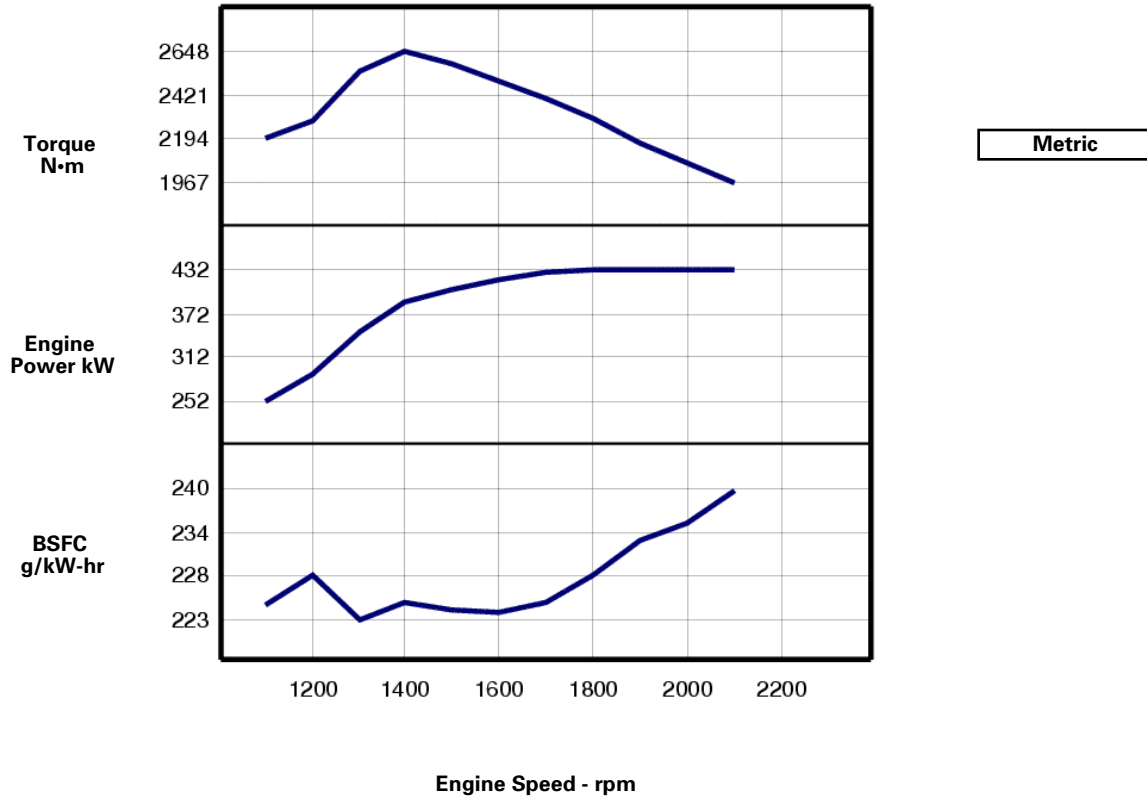

Engine Speed rpm	Engine Power kW	Torque N·m	BSFC g/kW-hr	Fuel Rate L/hr
2100	433	1967	239.9	123.7
2000	433	2065	235.6	121.5
1900	433	2174	233.2	120.2
1800	433	2294	228.7	117.9
1700	428	2402	224.9	114.6
1600	418	2497	223.6	111.5
1500	406	2582	224.2	108.4
1400	388	2648	225	104.1
1300	347	2545	222.6	92.0
1200	288	2292	228.8	78.5
1100	252	2190	224.7	67.6



**C15 ACERT™
Industrial Engine**

Tier 3/Stage IIIA

433 bkW/580 bhp @ 2100 rpm

PERFORMANCE CURVES

IND - D - DM7771-01

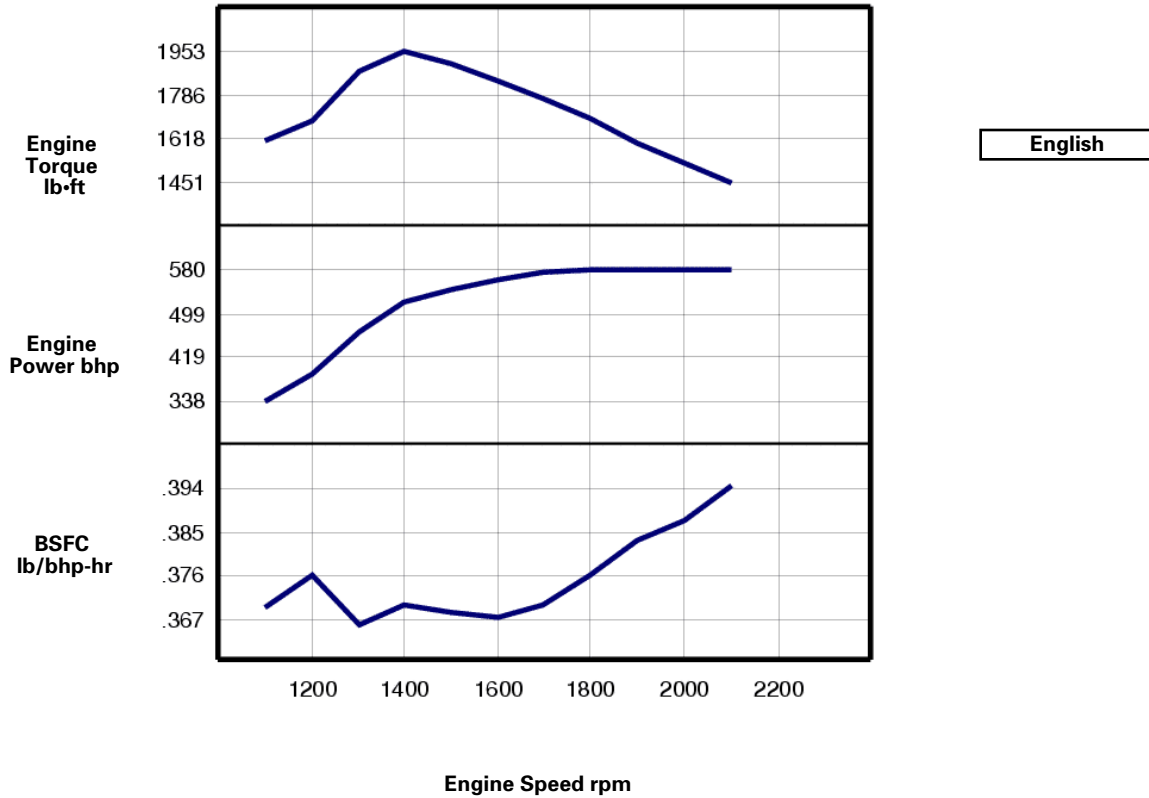

Engine Speed rpm	Engine Power bhp	Engine Torque lb-ft	BSFC lb/bhp-hr	Fuel Rate gal/hr
2100	580	1451	.394	32.7
2000	580	1523	.387	32.1
1900	580	1603	.383	31.8
1800	580	1692	.376	31.1
1700	573	1772	.370	30.3
1600	561	1842	.368	29.5
1500	544	1904	.369	28.6
1400	521	1953	.370	27.5
1300	465	1877	.366	24.3
1200	386	1690	.376	20.7
1100	338	1615	.369	17.9



**C15 ACERT™
Industrial Engine**
Tier 3/Stage IIIA
433 bkW/580 bhp @ 2100 rpm

RATINGS AND CONDITIONS

IND - D For service where maximum power is required for periodic overloads (time at full load not to exceed 10% of the duty cycle)..

Engine Performance Diesel Engines — 7 liter and higher
All rating conditions are based on SAE J1995, inlet air standard conditions of 99 kPa (29.31 in. Hg) dry barometer and 25°C (77°F) temperature. Performance measured using a standard fuel with fuel gravity of 35° API having a lower heating value of 42,780 kJ/kg (18,390 btu/lb) when used at 29° C (84.2° F) with a density of 838.9 g/L.

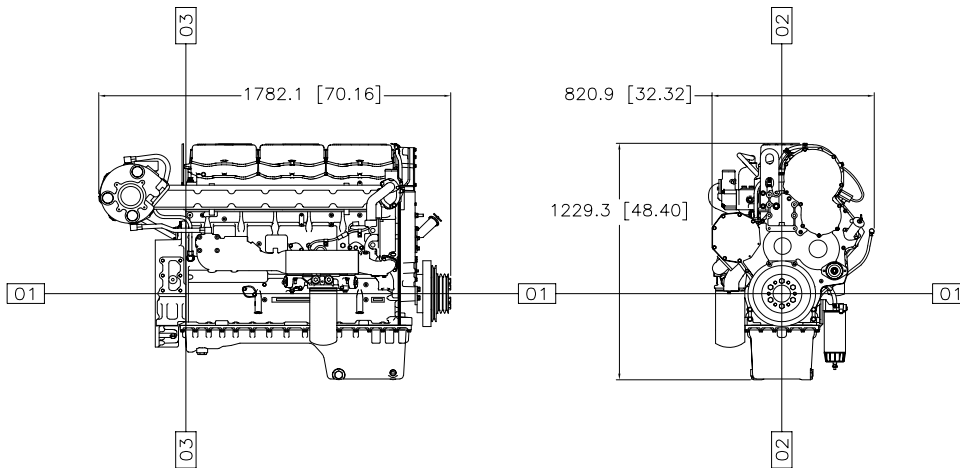

Engine Dimensions	
(1) Length	1380.9 mm (54.37 in)
(2) Width	926.4 mm (36.47 in)
(3) Height	1248.3 mm (49.15 in)

Note: Do not use for installation design. See general dimension drawings for detail (Drawing # 2579952).

Performance Number: DM7771-01
Feature Code: C15D113 Arr. Number: 2543835
Materials and specifications are subject to change without notice.
16287416

© 2012 Caterpillar
All rights reserved.

The International System of Units (SI) is used in this publication. CAT, CATERPILLAR, their respective logos, "Caterpillar Yellow," the "Power Edge" trade dress, as well as corporate and product identity used herein, are trademarks of Caterpillar and may not be used without permission.