



C13 ACERT™
Industrial Engine
Tier 3/Stage IIIA
287 bkW/385 bhp @ 2100 rpm



Image shown may not reflect actual engine

CAT® ENGINE SPECIFICATIONS

I-6, 4-Stroke-Cycle Diesel

Bore.....	130.0 mm (5.12 in)
Stroke.....	157.0 mm (6.18 in)
Displacement.....	12.5 L (762.8 in ³)
Aspiration.....	Turbocharged Aftercooled
Compression Ratio.....	17.3:1
Rotation (from flywheel end).....	Counterclockwise
Weight, Net Dry (approximate kg, lb).....	939 kg, 2070 lb

FEATURES

Emissions

Meets U.S. EPA Tier 3, EU Stage IIIA emission requirements.

Worldwide Supplier Capability

Caterpillar

- Casts engine blocks, heads, and cylinder liners.
- Machines critical components
- Assembles complete engine

Ownership of these manufacturing processes enables Caterpillar to produce high quality, dependable product.

Factory-designed systems built at Caterpillar ISO certified facilities.

Testing

Prototype testing on every model:

- proves computer design
- verifies system torsional stability
- tests functionality on every model

Every Caterpillar engine is dynamometer tested under full load to ensure proper engine performance.

Full Range of Attachments

Wide range of bolt-on system expansion attachments, factory designed and tested.

Unmatched Product Support Offered Through Worldwide Caterpillar Dealer Network

More than 1,500 dealer outlets.

Caterpillar factory-trained dealer technicians service every aspect of your industrial engine.

99.7% of parts orders filled within 24 hours worldwide.

Caterpillar parts and labor warranty.

Preventive maintenance agreements available for repair before failure options.

Scheduled Oil Sampling program matches your oil sample against Caterpillar set standards to determine:

- internal engine component condition
- presence of unwanted fluids
- presence of combustion by-products

Web Site

For all your industrial power requirements, visit www.cat-industrial.com.



C13 ACERT™ Industrial Engine

Tier 3/Stage IIIA

287 bkW/385 bhp @ 2100 rpm

STANDARD ENGINE EQUIPMENT

Air Inlet System

Air to air aftercooled (ATAAC)
Turbocharged

Control System

Electronic governing, PTO speed control
Programmable ratings
Cold mode start strategy
Automatic altitude compensation
Power compensation for fuel temperature
Programmable low and high idle and total engine limit
Electronic diagnostics and fault logging
Engine monitoring system
J1939 Broadcast (diagnostic and engine status)
ADEM™ A4

Cooling System

Thermostats and housing, vertical outlet
Jacket water pump, centrifugal
Water pump, inlet

Exhaust System

Exhaust manifold, dry
Optional exhaust outlet

Flywheels and Flywheel Housing

SAE No. 1 Flywheel housing

Fuel System

MEUI injection
Fuel filter, secondary (2 micron high performance)
Fuel transfer pump
Fuel priming pump
ACERT™ Technology

Lube System

Crankcase breather
Oil cooler
Oil filler
Oil filter
Oil pan front sump
Oil dipstick
Oil pump (gear driven)

General

Paint, Caterpillar Yellow
Vibration damper
Lifting eyes



**C13 ACERT™
Industrial Engine**

Tier 3/Stage IIIA

287 bkW/385 bhp @ 2100 rpm

PERFORMANCE CURVES

IND - A (Continuous) - DM7685-03

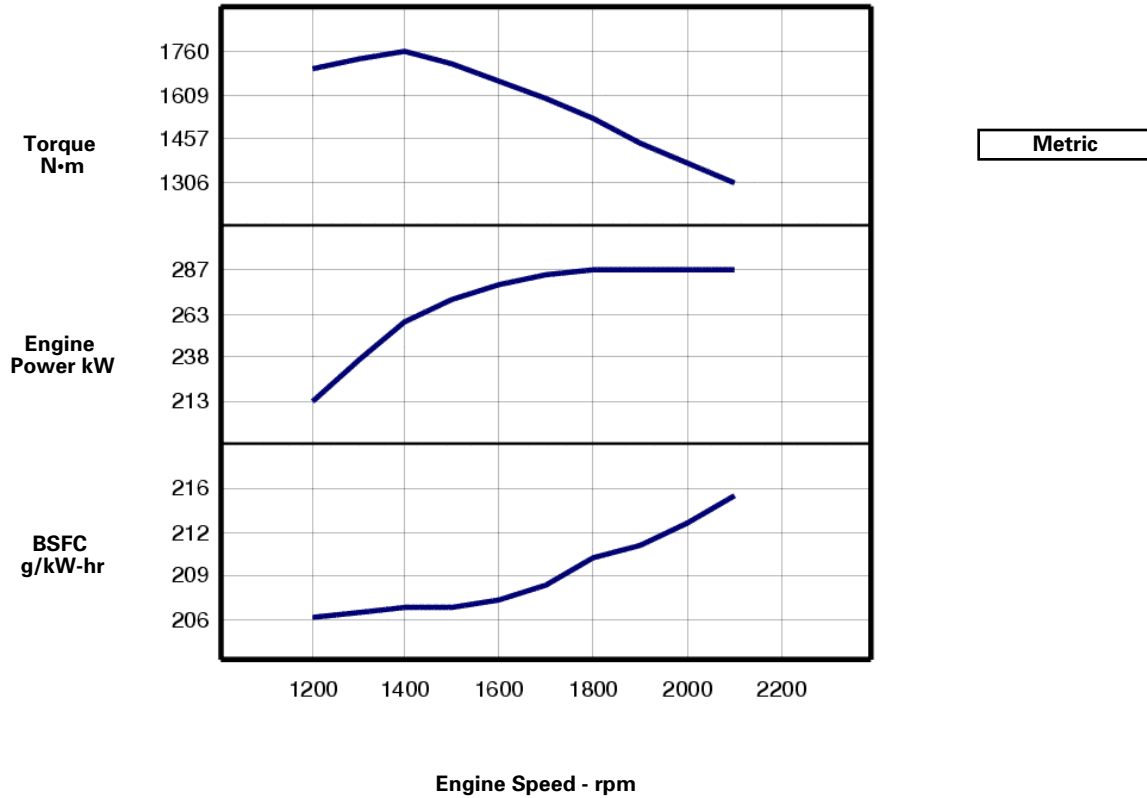

Engine Speed rpm	Engine Power kW	Torque N·m	BSFC g/kW-hr	Fuel Rate L/hr
2100	287	1306	215.8	73.9
2000	287	1371	213.5	73.1
1900	287	1443	211.7	72.5
1800	287	1524	210.6	72.1
1700	284	1596	208.4	70.6
1600	278	1659	207.1	68.6
1500	270	1716	206.6	66.4
1400	258	1760	206.5	63.5
1300	237	1737	206.2	58.1
1200	213	1698	205.7	52.3



C13 ACERT™ Industrial Engine

Tier 3/Stage IIIA

287 bkW/385 bhp @ 2100 rpm

PERFORMANCE CURVES

IND - A (Continuous) - DM7685-03

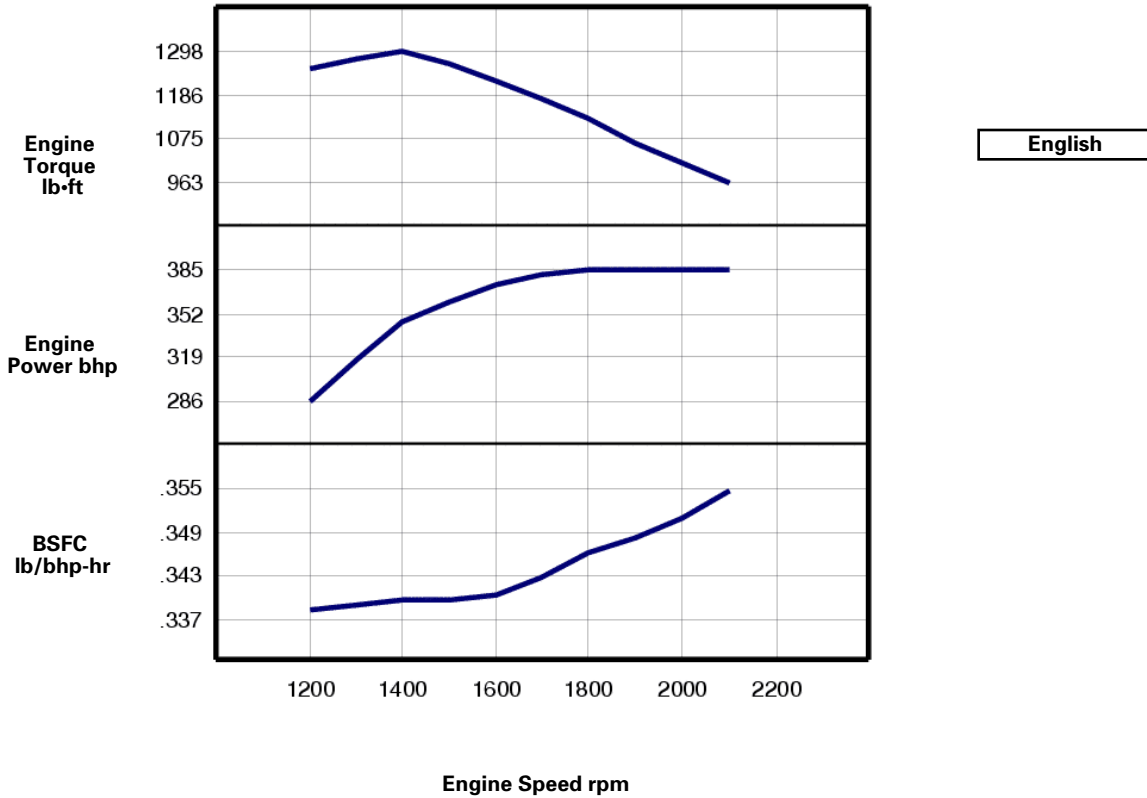

Engine Speed rpm	Engine Power bhp	Engine Torque lb-ft	BSFC lb/bhp-hr	Fuel Rate gal/hr
2100	385	963	.355	19.5
2000	385	1011	.351	19.3
1900	385	1064	.348	19.2
1800	385	1124	.346	19.0
1700	381	1177	.343	18.7
1600	373	1224	.340	18.1
1500	361	1266	.340	17.5
1400	346	1298	.339	16.8
1300	317	1281	.339	15.3
1200	286	1252	.338	13.8



C13 ACERT™ Industrial Engine

Tier 3/Stage IIIA

287 bkW/385 bhp @ 2100 rpm

RATINGS AND CONDITIONS

IND - A (Continuous) Continuous heavy duty service where the engine is operated at maximum power and speed up to 100% of the time without interruption or load cycling.

Engine Performance Diesel Engines — 7 liter and higher All rating conditions are based on SAE J1995, inlet air standard conditions of 99 kPa (29.31 in. Hg) dry barometer and 25°C (77°F) temperature. Performance measured using a standard fuel with fuel gravity of 35° API having a lower heating value of 42,780 kJ/kg (18,390 btu/lb) when used at 29° C (84.2° F) with a density of 838.9 g/L.

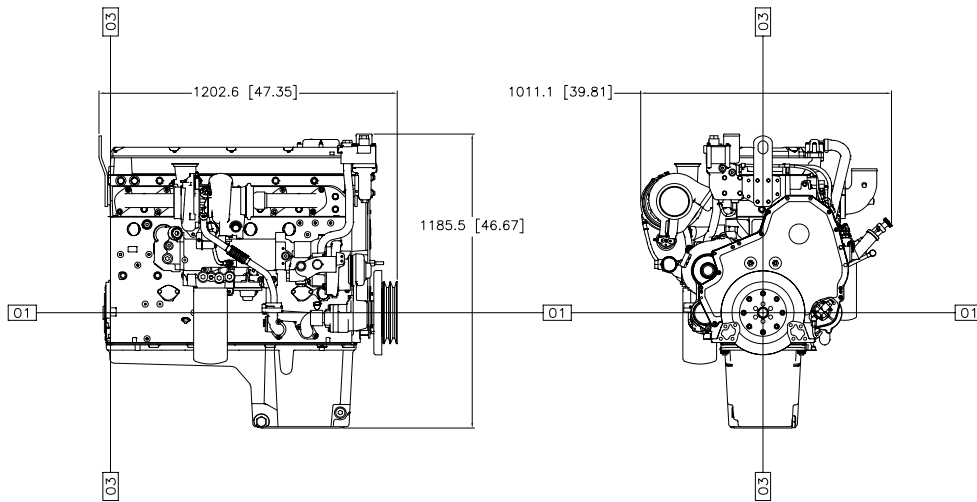

Engine Dimensions

(1) Length	1202.6 mm (47.35 in)
(2) Width	1011.1 mm (39.81 in)
(3) Height	1185.5 mm (46.67 in)

Note: Do not use for installation design. See general dimension drawings for detail (Drawing # 2588857).

Performance Number: DM7685-03

Feature Code: C13DI00 Arr. Number: 2413804

Materials and specifications are subject to change without notice.

16287056

© 2012 Caterpillar

All rights reserved.

The International System of Units (SI) is used in this publication.

CAT, CATERPILLAR, their respective logos, "Caterpillar Yellow," the "Power Edge" trade dress, as well as corporate and product identity used herein, are trademarks of Caterpillar and may not be used without permission.