

# 794 AC

Mining Truck



## Engine

Engine Model	Cat® C175-16	
Gross Power – SAE J1995	2610 kW	3,500 hp

## Operating Specifications

Nominal Payload Capacity	291 tonnes	320 tons
Gross Machine Operating Weight (GMW)	521 631 kg	1,150,000 lb

## 794 AC Features

### High Performance Engine

*The Cat C175-16 engine offers reliability and durability with proven performance in the large mining truck application.*

### Focus on Safety

*Wide access stairways, service platforms for the engine, traction alternator and control cabinet, four corner wet disc brakes, and industry leading retarding.*

### Enhanced Serviceability

*Open engine and traction alternator access, simplified hydraulics, grouped electrical and hydraulic routing, ground level filters and service points.*

### Reliable AC Electric Drive System

*The Cat AC electric drive power train is Caterpillar designed, integrated and supported.*

### Comfortable Cab

*Operators find the spacious and quiet cab offers excellent visibility with intuitive, easy to learn controls.*

### Truck Body Options

*Caterpillar designed and built bodies provide optimal performance and reliability.*

## Contents

Power Train – Cat AC Electric Drive .....	4
Power Train – Engine .....	6
Engine/Power Train Integration.....	7
Cat Braking System .....	8
Structures.....	9
Truck Body Systems .....	10
Monitoring System.....	11
Operator’s Station .....	12
Customer Support.....	14
Serviceability.....	15
Safety .....	16
Sustainability .....	17
Specifications.....	18
Standard Equipment.....	23
Optional Equipment.....	24
Notes.....	25





**Designed and manufactured by Caterpillar, the 794 AC electric drive truck is single sourced from one manufacturer and supported by the best dealer network. The 794 AC is designed to:**

- **Deliver a true 291 tonnes (320 tons) capacity**
- **Deliver reliability and uptime**
- **Deliver easy serviceability**
- **Deliver low owning and operating cost**
- **Deliver operator confidence with four corner wet disc blended service brakes and traction control**

**The 794 AC is built to deliver to your bottom line.**

# Power Train – Cat AC Electric Drive

Delivers you more power to the ground for greater productivity.



## **100% Caterpillar**

Designed and manufactured by Caterpillar, the 794 AC is a 291 tonnes (320 tons) AC electric drive truck that is single sourced from one manufacturer and supported with the best dealer network in the industry. The 794 AC drive system works seamlessly with the C175-16 engine and offers exceptional safety, serviceability and performance.

## **Modular Design for Excellent Serviceability**

The modular design allows for easy removal and installation of components. The engine, traction alternator, motors, inverter, grid, and final drives can be removed independently. The close coupled, dual bearing traction alternator allows for easy mounting to the C175-16 engine.

## **Superior Control Inspires Operator Confidence**

The Cat AC drive system gives you the best retarding, braking, and control in the industry. Class leading dynamic retarding coupled with blended service braking of the four corner wet disc brakes, provide the operator with exceptional control and confidence.

## **High Voltage – Lower Heat**

The Cat AC drive is a high voltage system (2,600 volts) that operates at lower current than the competition. The result is lower heat generation, smaller/lighter components, and longer component life.

## **The Cat AC Electric Drive in Propel**

The C175-16 diesel engine drives the close connected Traction Alternator/Generator through an isolation coupler. The AC power is rectified to a nominal 2,600 volts to form the DC link. The DC link supplies power to the Inverter where IGBT's convert the DC signal to 3-phase AC to drive the traction motors. Traction motor output drives the wheels through a double reduction ring gear output final drive.

## Cat AC Electric Drive in Retard

During retarding the traction/wheel motors act as generators and power is fed back through the DC link. The power is fed to the contactor and chopper circuits and then exhausted through the radial grid. An AC fan blows air across the grid to dissipate the power and control retarding speed.

## Traction Alternator

No shimming or radial alignment required with the close coupled, dual bearing alternator, resulting in decreased install time. The excitation system is brushless which has longer maintenance intervals than brush type systems.

## Inverter

Cat ECMs and software work with the Mitsubishi Electric IGBT Phase Modules to control the rimpull, direction and speed of the truck. Mitsubishi Electric IGBT technology is the proven leader for AC drive systems.

## Traction Motors

The 794 AC uses two 3-phase AC induction traction motors. The high voltage, low current motor is mounted inside the rear axle housing.

## Radial Grid

The radial design grid sits to the rear of the cab deck giving operators excellent visibility to the right side. The grid features the highest retarding power in the industry, better grid life, and is significantly quieter than box grids. The AC electric motor does not require any maintenance, which is a savings to the customer over DC motor systems.

## Variable Hydraulic Blower

The hydraulic drive blower motor offers exceptional cooling, even in extreme environments. The variable hydraulic blower has the ability to provide the required cooling, even while the truck is at idle, compared to direct drive motors that are dependent on engine rpm. The variable blower is better at keeping critical components cool, and ensures long component life.

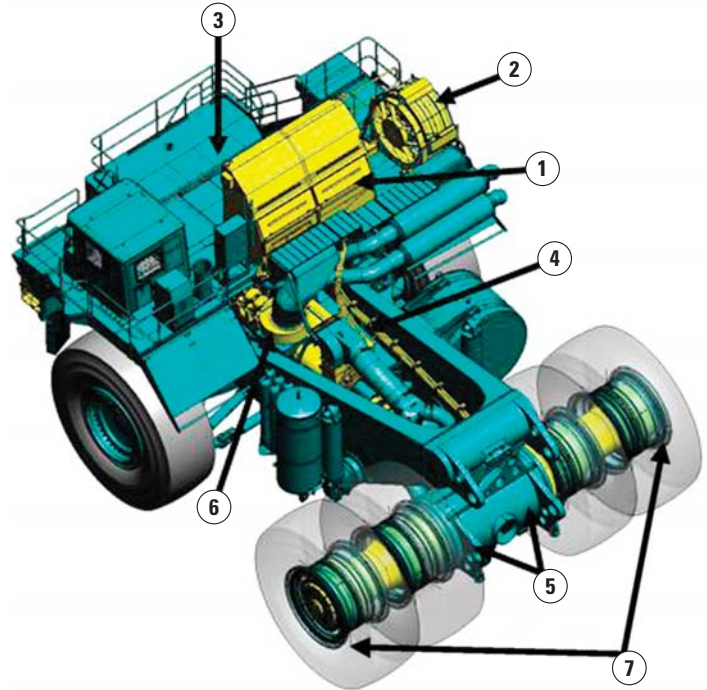

- 1) Control Power Inverter Cabinet
- 2) Radial Grid
- 3) C175-16 Engine
- 4) Traction Alternator
- 5) Traction Motor (inside axle box)
- 6) Variable Hydraulic Blower Motor
- 7) Final Drives

## Additional Features

- The grid dry function dries the grid quickly in inclement weather.
- Traction Control System (TCS) helps operators maintain control in poor underfoot conditions. TCS monitors and adjusts front and rear wheel speeds and independently adjusts them to prevent wheel slip and slide.
- Cat AC Drive system is Trolley capable.

# Power Train – Engine

Delivers power, reliability, and efficiency for your most demanding mining applications.

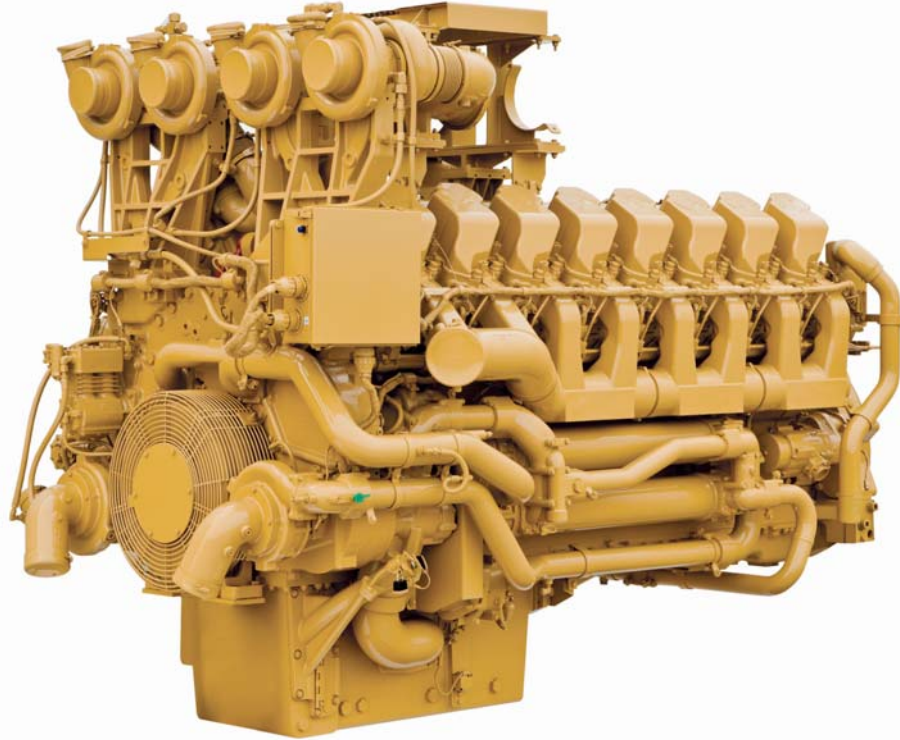

## Cat C175-16 Engine

The Cat C175-16 is a quad turbocharged air-to-air after cooled diesel engine that has enhanced power management capabilities for maximum hauling in your most demanding mining applications. The 16-cylinder, four stroke design uses long, effective power strokes for optimum efficiency.

## Engine Block

The C175-16 engine block is comprised of a high tensile strength ferrite ductile cast iron alloy. This design offers increased resistance to stress cracking and offers support to the cylinder liners, allowing for increased head gasket sealing capability.

## Serviceability

The design of the C175-16 enhances serviceability. The inlet manifolds and turbochargers are located outside of the engine's V, giving the service technicians more space to work on top of the engine and within the engine bay.

## Electronic Control Module (ECM)

The ECM utilizes advanced engine management software to monitor, control and protect the engine utilizing self-diagnosing electronic sensors.

## Pistons and Connecting Rods

A forged steel, one piece piston design has an improved stainless steel top ring set. The top ring reduces ring groove and liner wear and is corrosion resistant.

## Cat Common Rail Fuel System

The electronically-controlled system senses operating conditions and regulates fuel delivery for optimum fuel efficiency. This precise and flexible fuel system gives the engine the ability to meet emission regulations without sacrificing performance, reliability or durability.

# Engine/Power Train Integration

Delivers low operating costs through electronically combined power train components.



## Control Software and Integration

The Cat engine, AC drive system, hydraulics and controls have been integrated to make the truck easy to operate and provides:

- Excellent slow speed control for safety within the service areas.
- Superior throttle response on acceleration to move out of the loading or dump areas.
- Dynamic retarding with blended four corner wet disc service brakes, at low speed.

## Cat Data Link

Cat Data Link provides one location to access all machine information from all machine sub systems. Unique tools are not required to access the drive system, engine and machine information. All systems on the 794 AC are in constant communication with each other to:

- Optimize power train performance.
- Increase reliability and component life.
- Reduce operating costs.

# Cat Braking System

Delivers operator's confidence, to maximize your productivity.

## Industry Leading Dynamic Retarding

The radial grid is rated at 4.086 MW (5,480 hp) – allowing excellent control of the truck speed in long retarding applications. The radial design is light, efficient and quiet.

## Brake Design

The Hydraulic brake actuation system is electrically modulated so that the first 80% of brake pedal travel uses dynamic braking while the remaining 20% uses the wet disc service brakes. The emergency service brake pedal uses full hydraulic modulation of the wet disc brakes. The loading brake is used for under the shovel and applies the rear service brakes.

## Four Corner Wet Disc Brakes

The wet disc brakes provide the operator with excellent control and confidence in the truck. The front and rear Cat oil cooled brakes are designed with large discs and plates for reliable and adjustment free operation. They are enclosed and sealed to prevent contamination and provide long life. These oil disc brakes provide exceptional braking at all speeds.

## Dual Functioning Brake Pedal and Blended Braking

The dual functioning brake pedal gives the operator confidence when going downhill. The first 80% of the pedal activates only the dynamic brakes, but the operator has the ability to blend in the wet disc service brakes, with the remaining 20% of the brake pedal's range. When the operator is coming to a stop, the service brakes will automatically blend in at low speeds.

Full electric retarding effort will be maintained down to a truck speed of 3.2 km/h (2.0 mph). Blended braking of the service brakes (60/40 split rear and front service brakes) occurs between 3.6-4.0 km/h (2.25-2.5 mph) and will be used to completely stop the truck and hold it stationary.

## Automatic Retarding Control

Operator controlled – ARC engages automatically and maintains speed consistently. A simple toggle switch is used to adjust retarding speed, eliminating troublesome dials in competitor trucks.

## Anti-Rollback

Automatically applies service brakes to prevent the truck from rolling from a stop opposite the intended direction of travel.



## Reverse Shift Inhibit

Ensures reverse propulsion is not applied when the machine is moving forward, which helps prevent costly damage to the engine and drive system.

## Park Brake Alarm

Park brake alarm alerts the operator if he starts to exit the cab before the park brake has been applied. This feature helps prevent accidental movement.

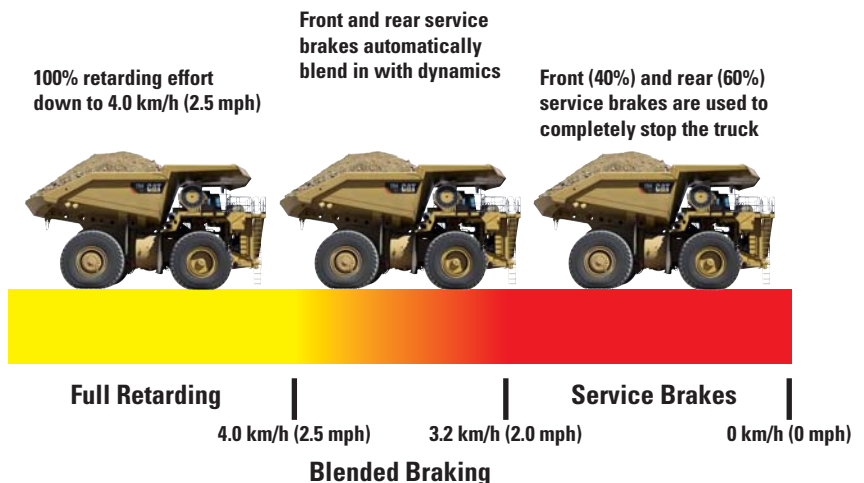





### Suspension System

The design of the suspension system utilizes Nitrogen/Oil suspension cylinders that feature pin to pin mounting to allow for access and change out of components without having to remove the tires.

- **Durable Design** – Double shear clevis attachment both top and bottom allows for easy removal and installation of suspension. The Nitrogen/Oil suspension cylinders reduce input loads into the structure for improved fatigue life and better ride.

## Structures

Cat structures are known for being the best in the industry for durability and long life.

### Straight Rail Frame

The 794 AC utilizes a straight rail design. The straight rail design eliminates bends and breaks, which occur at stress concentrations.

- **Box Section Construction** – The box section construction utilizes Caterpillar proprietary steel specification, which has very low sulfur content and provides excellent welding characteristics, plus outstanding durability.
- **Deep Section Main Rails** – Deep section main rails, in critical areas of the frame, lower the stress levels resulting in an increased frame life.
- **Tubular Center Cross Beam** – The tubular center cross beam with hoist cylinder and axle box attachment provides robust performance. The axle box attachment is integrated into the cross member and the bearing and pin are replaceable.

### Integrated ROPS Cab

Designed to maximize the operator space by deforming the support structure rather than compromise the operator compartment. The transverse mounting beams absorb energy by deflecting around established pivot points, maintaining the integrity of the operator compartment.

### Single Beam Front Axle

The single beam front axle is designed for load sharing on the beam, resulting in flatter turns and sharing of tire loading for better tire life. This lower structure absorbs the road undulations, giving a better ride and decreasing operator fatigue levels.



# Truck Body Systems

Delivers a true 291 tonnes (320 tons) and provides rugged performance and reliability.



## Integrated Body and Chassis Design

Integral to the truck the body is designed to fit with the chassis and work as part of the truck system. Each body is sized to meet the payload requirements without compromise to vehicle balance, braking or control.

## High Efficiency (HE) Body

The body is sized and configured to meet the specific needs dictated by fragmentation, abrasion, cohesion, and the loading tool to maximize the payload capability of the truck.

- Curved floor, front, and canopy strengthens entire body as a structure.
- Strength of base plates allows minimal wear package and low operating weight.
- Joint isolation system reinforces welded areas and exploits high strength main plates.
- Runners transfer weight to the truck frame.

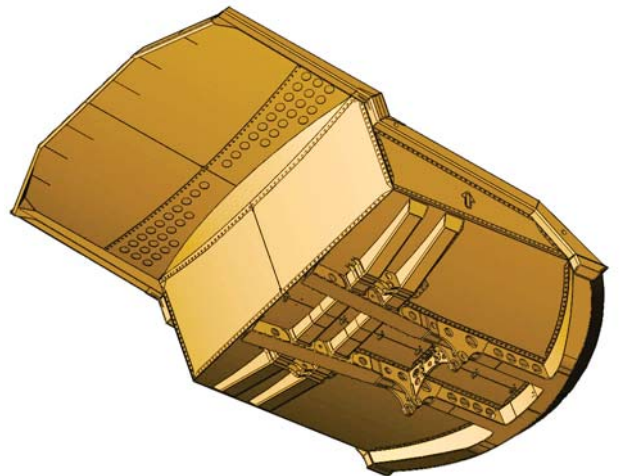

# Monitoring System

Keeping your production at peak levels.

## VIMS™ 3G Monitoring System

Provides operator critical health and payload information in real-time to keep the 794 AC performing at optimum levels. VIMS is able to monitor information from all vehicle systems. Ten (10) different machine parameters can be viewed at once. Data can be downloaded easily by service technicians for troubleshooting, planning and lowering costs.



## Advisor Display

The Advisor display provides real-time performance, maintenance and diagnostic data to the operator or service technician. A large number of machine parameters can be viewed including temperature, pressure, speed, and payload.

## Payload Management

Information is available to manage payloads to improve fleet effectiveness and loading tool match. It can help prevent overloading to extend component life and lower operating and maintenance costs.

## External Payload Indicators

Standard external lights or optional digit display to help loading tool operator reach payload target and minimize overloading.

## VIMSpC

An Off-board software reporting program that allows your service personnel to download a complete record of machine health and productivity data. Health and payload reports can be generated for more effective machine management, which reduces downtime and lowers operating costs.

## VIMS Supervisor

Optional software allows your mine personnel to easily manage and interpret VIMS data for optimum fleet management and productivity.

# Operator's Station

Ergonomically designed for all-day comfort, control and productivity.





## Operator Environment

The 794 AC cab can accommodate two full size reclining seats, while providing ample storage space behind the seats.

## Ergonomic Layout

To minimize operator fatigue and maximize productivity, the operator station is ergonomically designed for total machine control in a comfortable, productive, and safe environment. Controls, levers, switches and gauges are positioned for ease of use.

## Viewing Area

Designed for excellent all-around visibility and clear sight lines to the haul road, the large viewing area offers exceptional visibility, allowing the operator to maneuver with confidence for high productivity. The operator environment was designed with curved front glass to provide a 191-degree view. The support pillars have been moved further back to provide a more unobstructed front view. Deck compartments have been positioned to minimize impact on the side field of view.

- 1) Adjustable Steering Column
- 2) Turn Signals
- 3) Gauge Cluster
- 4) Advisor Display
- 5) 191-degree Viewing
- 6) Right Gauge Panel
- 7) Indicator Light Panel
- 8) Circuit Breakers (under dash)
- 9) Air Suspension Seat
- 10) Automatic Retard Control
- 11) 3-Point Seat Belt (driver) (2-Point companion)
- 12) Storage Compartment



# Customer Support

The most experienced dealer network in the world.

## Commitment to Meet Your Needs

Cat dealer 24/7 support offers solutions, services and products to help you lower costs, enhance productivity, and manage your fleet anywhere in the world. Expert technicians have the knowledge, experience, training, parts and tooling to keep your 794 AC running at high availability.

## Product Support

Caterpillar supports the 794 AC with a worldwide network of parts distribution, dealer service centers and technical training facilities. Our global dealer network is ready to meet your support needs around the clock and around the world.

## Service Support

Cat dealers offer a wide range of service plans to help maximize your uptime and return on your investment, including:

- Preventive Maintenance Programs
- Diagnostic Services such as Scheduled Oil Sampling and Technical Analysis
- Rebuild and Remanufactured Product Options
- Customer Support Agreements

## Application Awareness

Application and site-specific factors such as material density, loading practices, payload, speed, grade and haul road design and maintenance influence the cost to operate and maintain your haulage fleet. Your Cat dealer can provide help in understanding the effects application factors and operating practices have on maintenance and operating costs. They also offer training to help operators improve productivity, decrease downtime, reduce operating costs and enhance safety.

# Serviceability

Delivers easy service for more uptime and productivity.



## Modular Design

Major components can be serviced individually with minimal removal and installation time. Work platforms and step/stairs are located in key service areas. The close coupled, dual bearing, traction alternator is separate from the engine and can be removed without removing the body – traction/wheel motors are separate from final drives.

## Ground Level Access

Grouped service points (4 filter service groups) allow convenient access to tank levels, filters, drains and S-O-S<sup>SM</sup> oil sampling ports.

## Servicing Ease

- Open engine access with service platforms makes maintenance easy. Traction alternator and optional inverter platforms allow for easier inspections, troubleshooting, and component change outs.
- Hydraulic cabinet shows critical pressures for all key systems in one centralized location.

## Sealed Electrical Connectors

Electrical connectors are sealed to lock out dust and moisture. Harnesses are enclosed in conduit or braided for protection. Wires are color coded for ease of diagnosis and repair.

## Separate Hydraulic and Electric Lines

Hydraulic lines run inside the left side of the frame, while the electric lines run inside the right side of the frame. This makes servicing/replacement quick and easy.



# Safety

Designed with safety as the first priority.

## Product Safety is a Commitment

Caterpillar is concerned about your safety. We continue to be the industry leader in proactive development of machines and features that exceed safety standards.

## Controls

The Cat drive controls feature anti-roll back, traction controls, a park brake warning when exiting the cab and an automatic retarder that inspires operator confidence and error prevention.

## Isolation

The 794 AC features a ground level system lockout, engine lockout and propulsion lockout (in ECM cabinet), VIMS monitoring, and stored energy dissipation at shutdown. These features, and the excellent serviceability of the 794 AC, allow your technicians to perform repairs safely and quickly.

## Access/Egress

Standard 600 mm (24") wide ladders, flat deck, toe kicks, and optional power access stair attachment allows for easy and safe access and egress.





# Sustainability

Reduced maintenance time results in more productivity.



## Sustainability Features

The 794 AC Mining Truck offers continuous rear axle filtration and extended maintenance intervals which aid in decreasing the amount of waste contributed to our environment.

## Remanufacturing Options

794 AC trucks are designed to be rebuilt and deliver a long life, many 794 AC trucks have logged over 100,000 hours of frame life. Components are designed to be remanufactured for multiple service lives.

## Engines with Advanced Technology

Engines with advanced technology contribute to better fuel economy and decreased emissions.

## 12,000 Hour Coolant and Low Oil/Lube Consumption

794 AC has exceptionally low oil and lube consumption when compared to the competition. This provides a reduced impact on the environment, lower cost of ownership, and less maintenance time.



# 794 AC Mining Truck Specifications

## Engine

Engine Model	Cat C175-16	
Standard Gross Power – SAE J1995*	2610 kW	3,500 hp
Bore	175 mm	6.9 in
Stroke	220 mm	8.7 in
Displacement	85 L	5,187 in <sup>3</sup>

- \* Contact factory for low HP, lower emissions tier configurations and high altitude configurations.
- Power Ratings apply at 1,800 rpm when tested under the specified conditions for the specified standard.
- Ratings based on SAE J1995 standard air conditions of 25° C (77° F) and 99 kPa (29.61 Hg) dry barometer. Power based on fuel having API gravity of 35 at 16° C (60° F) and an LHV of 42 780 kJ/kg (18,390 BTU/lb) when engine used at 30° C (86° F).
- No engine derating required up to 1829 m (6,000 ft) altitude.
- Equivalent to U.S. EPA Tier 2 emission standards.

## Weights – approximate

Gross Machine Operating Weight	521 631 kg	1,150,000 lb
Chassis Weight	189 233 kg	417,187 lb
Body Weight	28 186 kg	62,140 lb

- Consult your tire manufacturer for maximum tire load.
- Chassis weight with 100% fuel, hoist, body mounting group, rims, and tires.
- Body weight varies depending on how body is equipped.

## Operating Specifications

Nominal Payload Capacity	291 tonnes	320 tons
Top Speed – Loaded	60 km/h	37 mph
Steer Angle	39 degrees	
Minimum Turning Radius	16.2 m	53 ft

- Payload assumes no debris, no extra options or attachments.
- Refer to the Cat Mining Truck 10/10/20 Overload Policy (AEXQ0250) for maximum gross machine weight limitations.

## Final Drives

Total Reduction Ratio	35:1
-----------------------	------

## AC Drive System

Generator/Alternator	Brushless, engine mounted, dual bearing
Controls	IGBT Inverter Technology, air cooled, pressurized cabinet with filtration
Wheel Motor	Cat AC induction, rear axle mounted
Cooling System	Variable speed, hydraulically driven cooling system

## Tires

- 53/80 R63.
- Production capabilities of the 794 AC truck are such that, under certain job conditions, TKPH (TMPH) capabilities could be exceeded and, therefore, limit production.
- Caterpillar recommends the customer evaluate all job conditions and consult tire manufacturer for proper tire selection.

## Braking System

Front Wet Disc Brake Surface Area	131 473 cm <sup>2</sup>	20,378 in <sup>2</sup>
Rear Wet Disc Brake Surface Area	198 388 cm <sup>2</sup>	30,750 in <sup>2</sup>
Standards	ISO 3450:2011	
Electric Retarding – Radial Grid Design		
Dynamic Retarding Power		
Continuous	4086 kW	5,480 hp

## Weight Distributions – approximate

Front Axle – Empty	49%
Rear Axle – Empty	51%
Front Axle – Loaded	33%
Rear Axle – Loaded	67%

# 794 AC Mining Truck Specifications

## Capacity – HE Body – 100% fill factor

Struck	108-133 m <sup>3</sup>	142-175 yd <sup>3</sup>
Heaped (SAE 2:1)	180-222 m <sup>3</sup>	236-290 yd <sup>3</sup>
Dump Body Plate Thickness Varies Depending on Body Selection		
Floor Plate	16 mm	0.63 in
Front Plate	9 mm	0.35 in
Side Plate	8 mm	0.31 in
Canopy Plate	5 mm	0.20 in

- Contact your local Cat dealer for body recommendations.

## Service Refill Capacities

Fuel Tank	4922 L	1,300 gal
Cooling System	799 L	211 gal
Crankcase	310 L	82 gal
Final Drives, each	254 L	67 gal
Hydraulic Tank	1121 L	296 gal
Hydraulic System (includes tank)	1458 L	385 gal

## ROPS

### ROPS Standards

- ROPS (Rollover Protective Structure) meets ISO 3471:1994.
- FOPS (Falling Object Protective Structure) meets ISO 3449:1992.

## Sound

### Sound Standard

- The operator sound pressure level measured according to work cycle procedures specified in ISO 6394 and 6396 is 75 dB(A) for cab offered by Caterpillar when properly installed, maintained, and tested with doors and windows closed.
- Hearing protection may be needed when operating with an open operator station and cab (when not properly maintained or doors/windows open) for extended periods or in a noisy environment.

## Steering

Steering Standards ISO 5010:2007

- Gross Machine Operating Weight is 521 631 kg (1,150,000 lb).

# 794 AC Mining Truck Specifications

## Dimensions

All dimensions are approximate.  
Shown with 1936 m<sup>3</sup> (253 yd<sup>3</sup>) HE Body.

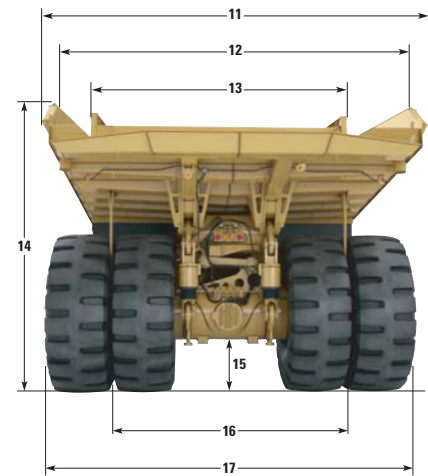
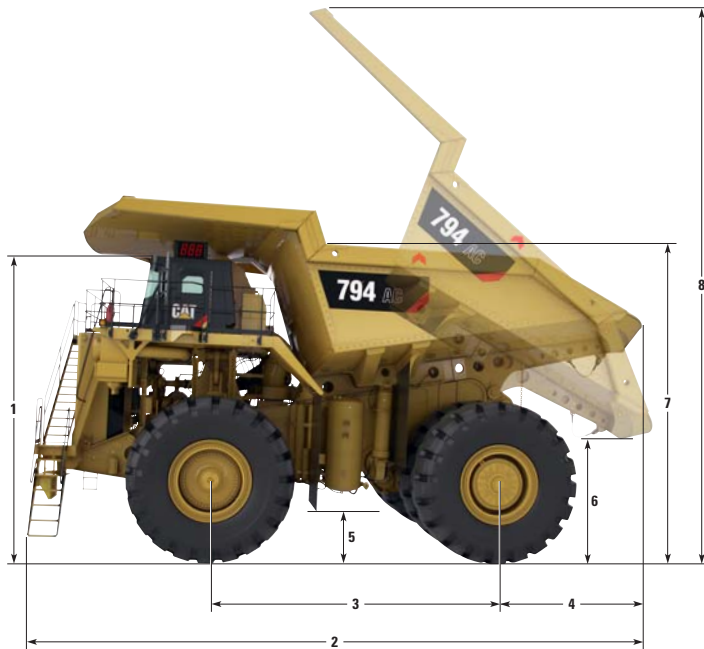

1	Height to Top of ROPS	6779 mm	22'3"
2	Overall Length	15 463.5 mm	50'9"
3	Wheelbase	6644.5 mm	21'10"
4	Rear Axle to Tail	4716 mm	15'6"
5	Ground Clearance	906 mm	2'8"
6	Dump Clearance	1555 mm	3'0"
7	Loading Height – Empty	6995 mm	22'11"
8	Overall Height – Body Raised	14 747 mm	48'5"
9	Centerline Front Tire Width	7024 mm	23'0"
10	Front Axle Clearance	969 mm	3'2"
11	Overall Canopy Width	9763 mm	32'0"
12	Outside Body Width	9062 mm	29'9"
13	Inside Body Width	8560 mm	28'1"
14	Front Canopy Height	8024 mm	26'4"
15	Rear Axle Clearance	934 mm	3'1"
16	Centerline Rear Dual Tire Width	5727 mm	18'9"
17	Overall Tire Width	8738 mm	28'8"

# 794 AC Mining Truck Specifications

## Gradeability/Speed/Rimpull\*

To determine gradeability performance: Read from gross weight down to the percent of total resistance. Total resistance equals actual percent grade plus 1% for each 10 kg/t (20 lb/ton) of rolling resistance. Usable rimpull will depend upon traction available and weight on drive wheels.

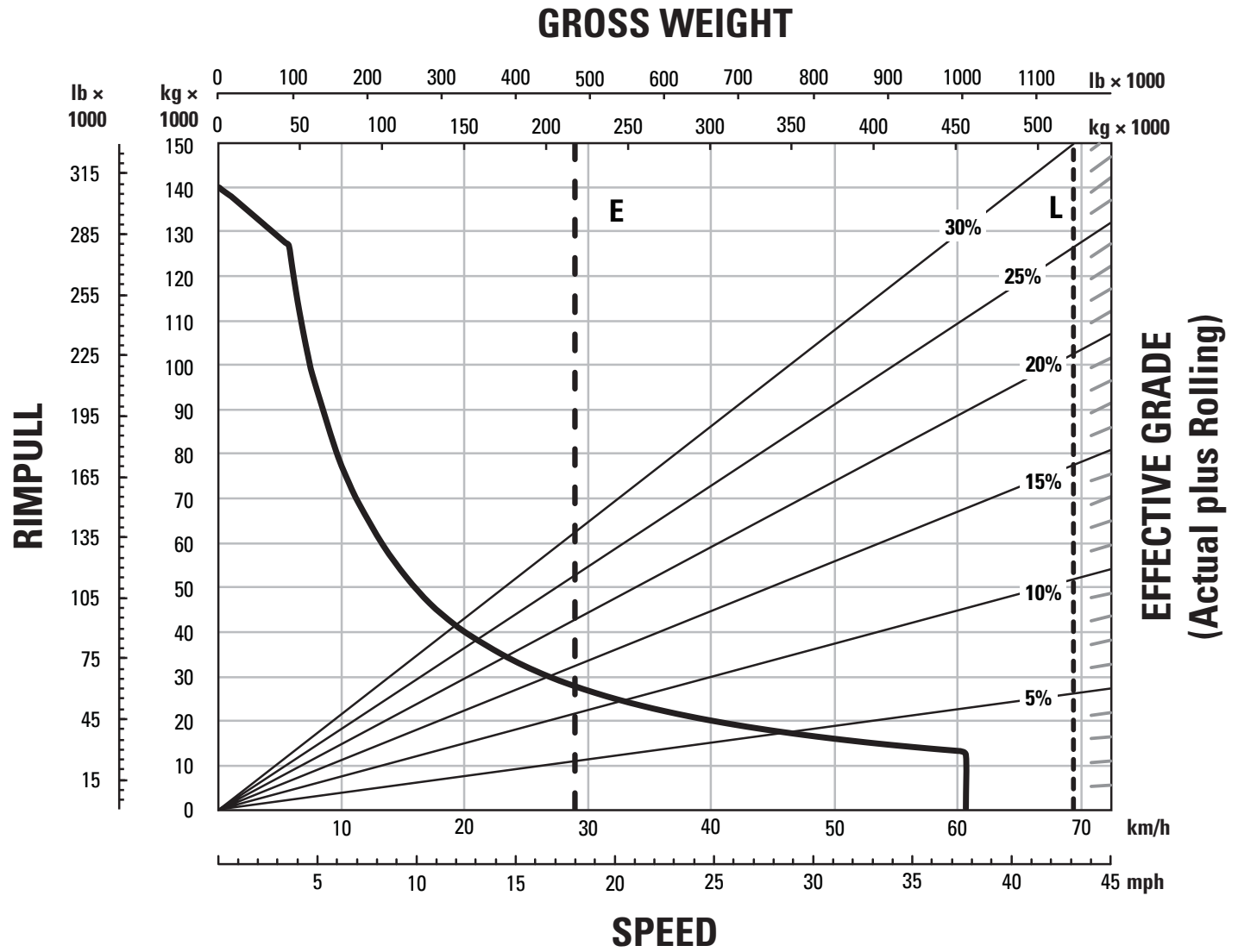

\*At sea level, 30° C (86° F). Contact factory for performance estimates based upon site specific temperatures and altitudes.

# 794 AC Mining Truck Specifications

## Retarding Performance\*

To determine retarding performance: Read from gross weight down to the percent effective grade. Effective grade equals % grade minus 1% for each 10 kg/t (20 lb/ton) of rolling resistance. The following chart is based on 30° C (86° F) ambient temperature, at sea level, with 53/80 R63 tires.

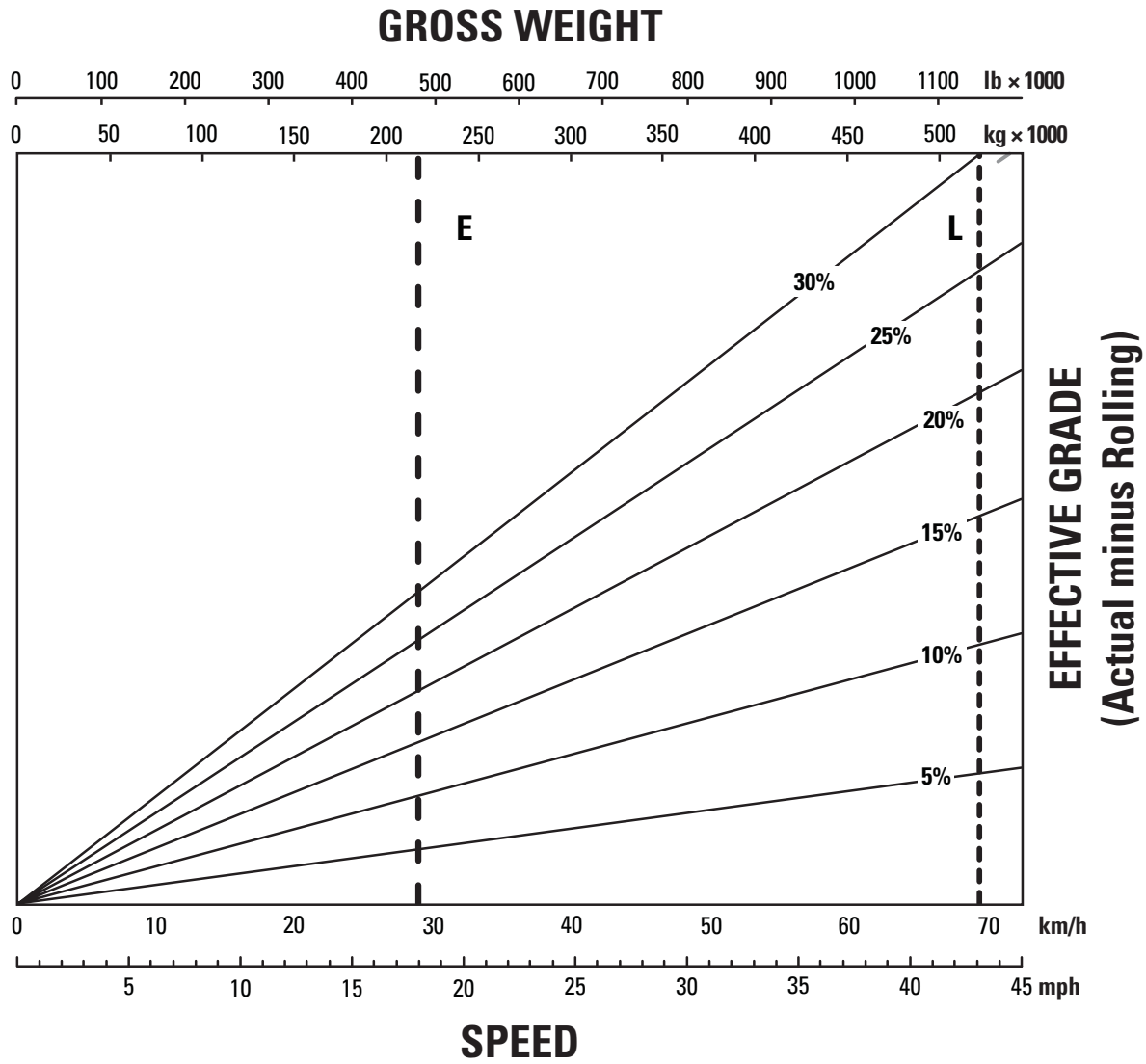

## CONTINUOUS GRADE LENGTH

### KEY

E – Empty Operating Weight 217 419 kg (479,327 lb)

L – Target GMW 521 631 kg (1,150,000 lb)

\*At sea level, 30° C (86° F). Contact factory for performance estimates based upon site specific temperatures and altitudes.

## Standard Equipment

Standard equipment may vary. Consult your Cat dealer for details.

### POWER TRAIN

- C175-16 Tier 2 equivalent emission standards
- Diesel engine:
  - Turbocharging (4)/aftercooled
  - Air to air after cooler (ATAAC)
  - Air cleaner (4) with precleaner
  - Elevated low idle control
  - Multi-point oil pressure sensing
  - Pre-lubrication/engine
- Braking system:
  - Brake release towing
  - Oil-cooled, multi-disc (front and rear) (service, retarding, parking, secondary)
  - Automatic Retarder Control
  - Electric dynamic retarding with blended low speed
  - Extended life brake disc material
- Cat AC drive train:
  - IGBT controlled AC induction motors
  - AC generator
  - AC cooled radial grid
- Body-up reverse neutralizer
- Programmable top speed
- Rear axle continuous lube/filtration
- Reverse shift inhibitor
- Directional shift management
- Neutral coast inhibitor
- Body-up shift inhibitor
- Neutral start inhibitor

### ELECTRICAL

- Alarm, backup
- Brushless alternator 150 amp charging
- Batteries – 12V (8) 90 amp hour
- Converter, 12V electrical
- Electrical system, 24V, 10, 15, 20 amp fuses and breakers
- Battery charge receptacle
- Lighting, signals/service:
  - Halogen lighting package
  - Backup and hazard lighting
  - Directional signals (front and rear LED)
  - Front stair access/service deck
  - Stop/tail lights (LED)
  - Engine compartment
  - Inverter energy LED warning lights

### OPERATOR ENVIRONMENT

- Air conditioner
- 12V DC power supply (1)
- Cup holder (2)
- Diagnostic connection port
- Dome courtesy light
- Entertainment radio ready:
  - 20 amp switched/10 amp memory converter
  - Speakers, and wiring harnesses
- Gauges/indicators
- Gauge panel:
  - Hydraulic oil temperature
  - Engine coolant temperature
  - Fuel level
  - Electric engine control fault indicator
  - Electric hour meter
  - Speedometer
  - Tachometer
  - VIMS message center advisor
- Heater/defroster
- Storage space behind seat
- ROPS cab, insulated/sound suppressed
- Seat, operator, air suspension
- Seatbelt, operator, three points
- Seat, trainer, air suspension
- Seatbelt, trainer, two point
- Steering wheel, tilt, telescopic
- Tinted glass
- Window, electric powered, operator/passenger
- Wiper, windshield, intermittent control and washer
- Fixed access ladder

### FLUIDS

- Extended life coolant to –35° C (–30° F)

### OTHER STANDARD EQUIPMENT

- Traction control system
- Auxiliary “buddy” dumping quick connect
- Auxiliary steering quick connect (towing)
- Rotating component guards
- Fast fill fuel system (LH and RH side)
- Fuel filter with water separator
- Ground level battery lockout
- Machine lockout
- Engine start lockout
- ECM cabinet lockout
- Ground level engine shut-down
- Rock ejectors (chain)
- Tow hooks and pin (front)
- Tow pin (rear) (empty truck only)
- Mudflaps
- Coolant level gauge (on radiator)
- Automatic lubrication system
- S·O·S sample points (hydraulic, cooling, engine)

# 794 AC Optional Equipment

## Optional Equipment

Optional equipment may vary. Consult your Cat dealer for details.

- Contact factory for low HP, lower emissions tier configurations and high altitude configurations
- Throttle lock
- Timer, engine shutdown
- Body heat exhaust
- Gel batteries (8)
- High Intensity Discharge (HID) lighting package
- LED lighting package
- Fog lights
- LED work lights
- English or Metric gauges
- Payload, digital display
- Powered access ladder
- Inverter platform
- Fast fill fuel system (front and right)
- Rims: Six (6) position and quick change
- ANSI and ISO service instructions
- Retarding indicator light
- Cab pedestal for additional display
- Radio/CD player
- Front bumper center tow attachment
- Brake wear indicator tool
- Coolant  $-50^{\circ}\text{C}$  ( $-58^{\circ}\text{F}$ )
- HE dump body rock box liner
- HE dump body canopy rock deflectors
- Heated mirrors (LH and RH)
- Rear axle oil cooler
- Standard accumulators and Australia/Canada certified accumulators
- Hot start, for cold weather
- Diesel fuel warmer
- Wheel chocks (ANSI or ISO)
- Portable fire extinguisher
- Murphy gauge
- High efficiency dump body
  - $1543\text{ kg/m}^3$  ( $2,600\text{ lb/yd}^3$ ) density body
  - $1721\text{ kg/m}^3$  ( $2,900\text{ lb/yd}^3$ ) density body
  - $1839\text{ kg/m}^3$  ( $3,100\text{ lb/yd}^3$ ) density body
  - $2076\text{ kg/m}^3$  ( $3,500\text{ lb/yd}^3$ ) density body
- Canopy extension
- Body rock box
- Side profile lighting
- Central service
- Language monitors – English, Spanish, Italian, Portuguese, Dutch, Norwegian, Swedish, Estonian, Latin, Lithuanian, Slovakian, Slovenian, Greek, Romanian, Russian, Polish, Czech, Hungarian, Icelandic, Finnish, Danish, Thai, Indonesian, Vietnam, Malaysian, Chinese









For more complete information on Cat products, dealer services, and industry solutions, visit us on the web at [www.cat.com](http://www.cat.com)

AEHQ7160-03 (05-2016)  
Replaces AEHQ7160-02

© 2016 Caterpillar  
All rights reserved

Materials and specifications are subject to change without notice. Featured machines in photos may include additional equipment. See your Cat dealer for available options.

CAT, CATERPILLAR, SAFETY.CAT.COM, their respective logos, "Caterpillar Yellow" and the "Power Edge" trade dress, as well as corporate and product identity used herein, are trademarks of Caterpillar and may not be used without permission.

