



Enclosure pictured may include optional accessories

## Modular Acoustic Enclosures

### GEM260-1

Developed through continuing research and development by our specialist engineers, all Olympian™ enclosures are fully weatherproof and incorporate internally mounted exhaust silencers. Designed on modular principles, they have interchangeable components permitting on-site repair.

Extremely durable and robust, the enclosures are designed to resist corrosion and handling damage with the ability to withstand rough handling common on many construction sites.

## FEATURES

### SECURITY AND SAFETY

- Control panel viewing window in a lockable access door
- Emergency stop push button (red) mounted on enclosure exterior
- Cooling fan and battery charging alternator fully guarded
- Fuel fill and battery can only be reached via lockable access doors
- Exhaust silencing system totally enclosed for operator safety

### TRANSPORTABILITY

- Optional tested and certified lifting arch
- Lifting points on baseframe

### ROBUST/ HIGHLY CORROSION RESISTANT CONSTRUCTION

- Galvanised steel protected by powder coat paint
- Stainless steel locks and hinges
- Zinc plated or stainless steel fasteners

### EXCELLENT ACCESS FOR MAINTENANCE

- Two large doors on each side
- Radiator fill access plate
- Lube oil drain valves / Coolant drain valves

### SOUND PRESSURE LEVELS (dBA)

Generator Set Model		60 Hz							
		15 m (49 ft)		7 m (23ft)		1.5 m (4.9 ft)		1 m (3.3 ft)	
		75% Load	100% Load	75% Load	100% Load	75% Load	100% Load	75% Load	100% Load
GEM260-1	Prime	65.4	66.6	71.4	72.6	79.8	81.0	82.2	83.4
	Standby	65.8	67.1	71.8	73.1	80.1	81.5	82.6	83.9

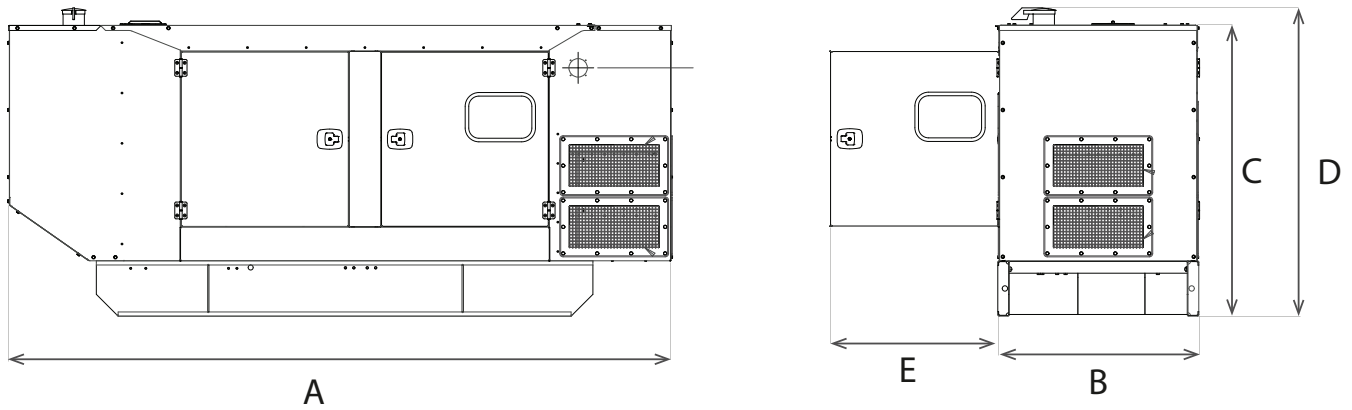

### DIMENSIONS AND WEIGHTS

Generator Set Model	A: mm (in)	B: mm (in)	C: mm (in)	D: mm (in)	E*: mm (in)	Weight: kg (lb)	Fuel Capacity: l (US gal)
GEM260-1	3964 (156.1)	1200 (47.2)	1732 (68.2)	1837 (72.3)	995 (39.2)	2216 (4885)	433 (114.4)

\*Clearance required both sides; Weight with lube oil, no coolant, no fuel.