

VM 43 C

Long-Stroke Diesel Engines
for Maximum Efficiency and
High Reliability

12 • 16 Cylinder

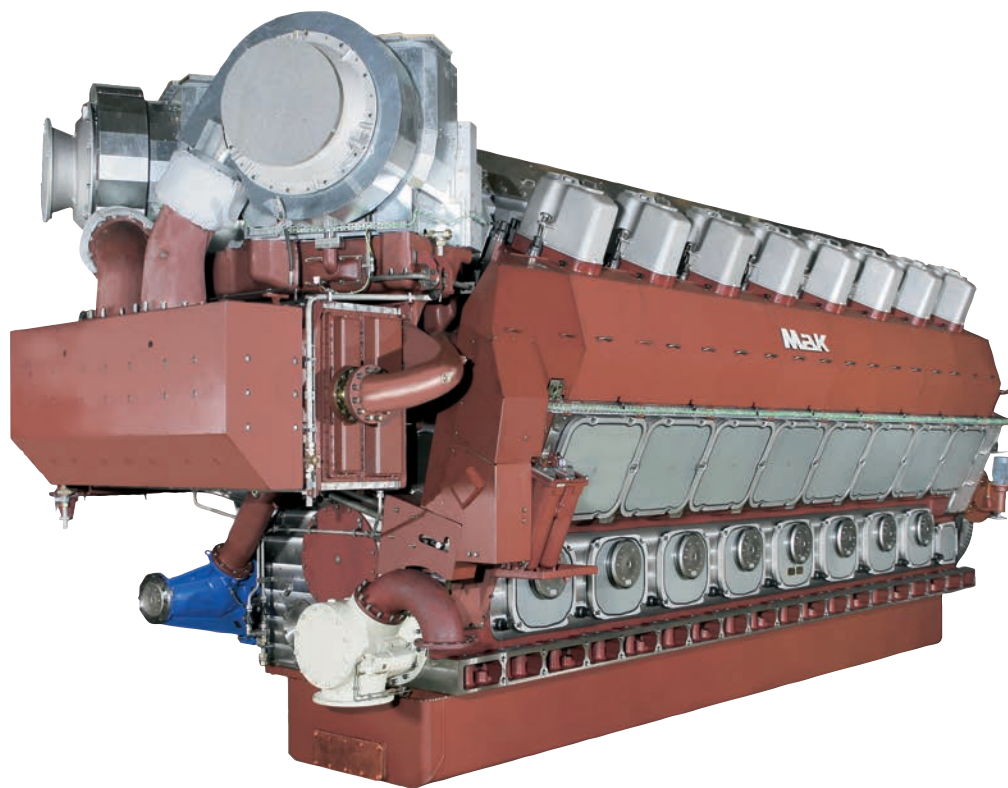

BUILT FOR IT.™

MAK

VM 43 C – The Power to meet High Requirements

Developed to meet the requirements of the cruise ship and ferry markets, this new engine series is the breakthrough into a new class of power. Designed state-of-the-art, engineered to lead.

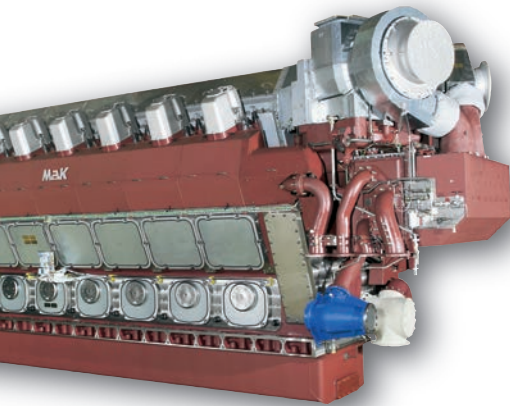

After the successful introduction to the market of four new engine series in only ten years, the extension to the program continues with a further engine – the M 43 C V-engine. The 12 and 16 cylinder V-version of the M 43 C doubles the power on offer from Caterpillar to 16 MW and therefore supports new and important market segments and groups of customers.

The successful origin

The external configuration of the engine clearly and impressively displays the origin of the V-engine M 43 C – a compact, simple and clean design which exhibits the features of the technically and commercially extremely successful in-line engine version. The modular design of the engine, the integration of various functions in one component, the robust structure and the use of components already proven in the in-line version lead to an outstandingly high level of reliability.

Highly economical

Reliable heavy oil operation and low fuel and lubricating oil consumption, simple maintenance and long maintenance intervals ensure highly economical operation. The long stroke, high-pressure injection and optimized combustion ensure that the IMO limits are securely met. As an option, this engine includes – as a first – the newly developed “Flexible Camshaft Technology”. It ensures even less environmental pollution.

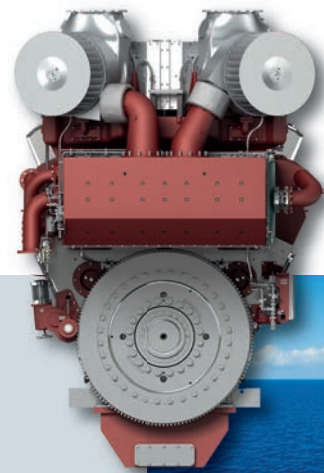

To ensure luxurious lifestyle on board, the propulsion plant plays an important role.

The benefits with the VM 43 C are:

- When talking about comfortable cruising, we mean: low emissions and low noise.
- When talking about high reliability, we mean: sailing on schedule.
- When talking about low operating costs, we mean: quick return of investments.

The VM 43 C has been specially designed to meet the high requirements of the marine engine markets for cruise ships and ferries but also for other specialized ship types.

High standards on cruise ships

Cruise ships and passenger vessels are the unchallenged sovereigns of the seas. These are the elegant, majestic and mighty giants that cross the oceans. To ensure that passengers enjoy luxurious life-style on board, these ships require a propulsion that is powerful yet cannot otherwise be noticed. The top priority is thus an engine with low noise, vibration and emission levels. The source of this power is calm strength with the VM 43 C quietly at work in the background.

RoPax ferries in focus

The requirements made on combined freight and passenger ferries have changed considerably in recent years. The top priority is no longer just speed and plenty of space. High standards of comfort, as on a classic cruise ship, are becoming increasingly important, and that requires state-of-the-art, environment-friendly and powerful engines causing little in the way of vibration or noise. On RoPax ferries, the focus is increasingly on the trip itself. The higher standards also mean that new requirements are placed on the propulsion plant. The VM 43 C was designed for optimally meeting these needs.

We assist you from the planning stage all the way through to final delivery. Benefit from our expertise and experience: the VM 43 C has already fully demonstrated its excellence powering, for example, the "Pont-Aven" deployed by Brittany Ferries. Discover the new generation of highly sophisticated marine propulsion systems.



VM 43 C – Design Features

The smallest parts determine the efficiency of the whole. The basic principle in the design and development of a V-engine series at Caterpillar is to use as many components as possible from the in-line engine version already in operation.

In the M 43 C V-engine, therefore, the basic design data such as bore, stroke and engine speed have been taken over completely from the in-line engine. In consequence, important components, such as cylinder head, connecting rod, piston crown, cylinder liner with calibration ring, injection pump, valve drive, cooling water ring and turbocharger, could be transferred from the in-line engine version without design changes.

For all these components, comprehensive operating experience, which impressively document their reliability and economy, are already available.



Cylinder head

- Complex component in nodular cast iron, stiffness from twin-bottom design
- Intensive cooling of combustion chamber and exhaust valves
- Integrated media ducts reduce piping requirements
- Simple and reliable maintenance



Connecting rod

- Robust design for reliable operation
- Split shaft for simple, rapid and error-free dismantling



Piston crown

- Forged piston crown with only three piston rings for high ignition pressure strength and long life
- An uncluttered combustion chamber without valve pockets for optimum combustion and low fuel consumption



Cylinder head

- Reliable MaK valve technology
- Exhaust valves in Nimonic with vanes
- MaK nozzle technology for long nozzle life

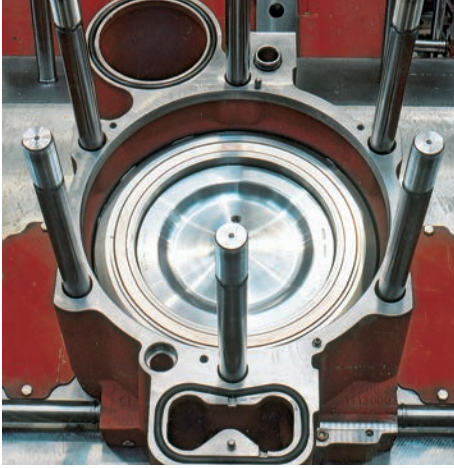

Cylinder liner with calibration ring

- Long lifetime with piston removal intervals of 30,000 hours in heavy fuel operation
- Low lubricating oil consumption
- Long oil change intervals
- Very simple maintenance



Turbocharger

- Turbocharger with sliding bearings, no water cooling, connected to the lubricating oil circuit, service-friendly
- Maximum power rapidly available
- Low thermal loading on the turbocharger components
- High boost pressures over the complete speed range



Engine block

- Multifunctional component due to integration of oil ducts, boost air and camshaft passages, gearwheel drive and suppressor area



Multifunctional cooling water ring

- Engine block free of cooling water to avoid corrosion
- Ensures intensive cooling of the cylinder head and cylinder liner upper region
- High level of operational reliability due to reduced number of components
- Very simple maintenance

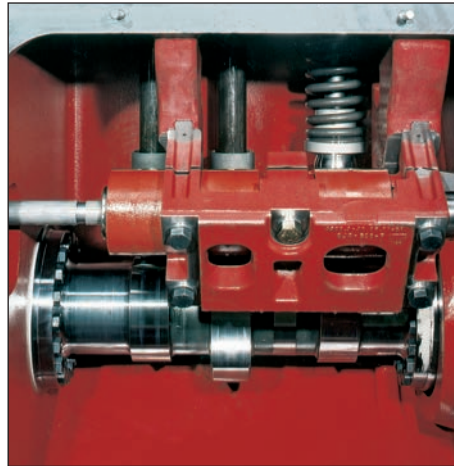

Valve Drive

- Compact, modular design facilitates maintenance work on the camshaft bearings



VM 43 C – Design Features



Crankshaft

- Full counterweight set
- Maximum security against bearing fretting and consequential camshaft damage
- Low loads due to powerful bearing trunnions and wide bearings
- New MaK bearing shell technology ensures a high level of operational reliability

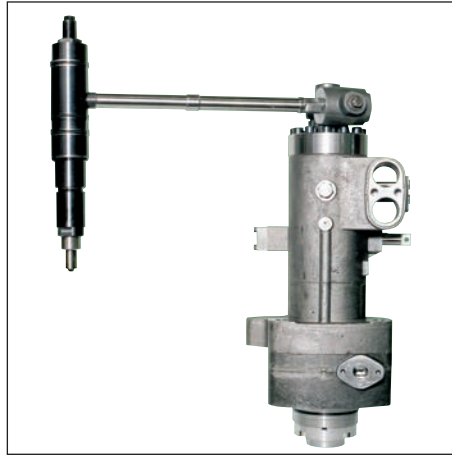

Injection pump

- High injection pressures
- Short, compact injection lines with reliable injection protection
- Secure assembly on the engine block
- Optimum fuel injection into the combustion chamber and, in consequence, high efficiency

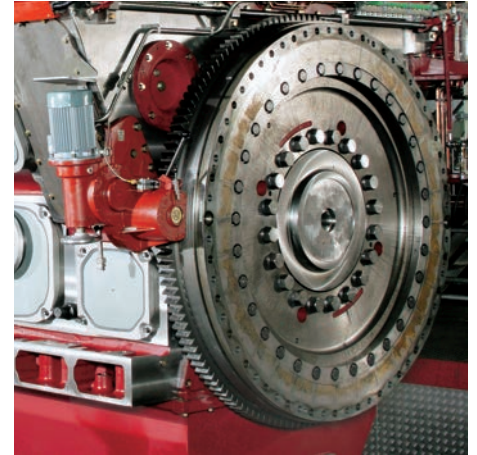

Flywheel

- The flywheel hub is shrunk onto the crankshaft by means of an oil shrink type connection
- The flywheel ring is flanged onto the hub

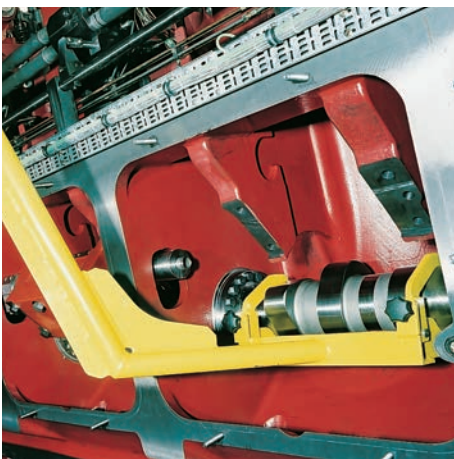

Camshaft

- The camshaft is, as built, equipped with vibration dampers
- Easy piecemeal removal of parts possible for inspection of the bearings



Turbocharger connection

- The V-position of the turbocharger permits optimum air induction and minimum center distance in the case of multi-engine installations
- Low turbocharger installation height
- Low vibration operation
- Block cooler connection which is economical in space

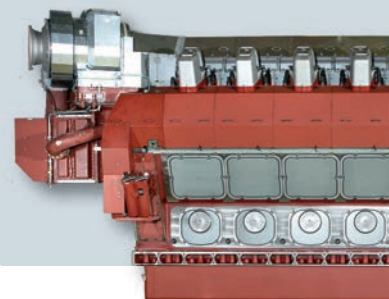



Large inspection hatches

- Large inspection hatches ensure satisfactory access to the engine and camshaft areas

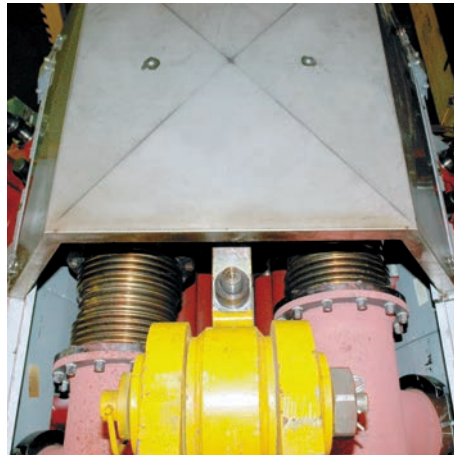

Exhaust pipe cladding

- The cladding is subdivided into segments and can be easily and rapidly removed and installed

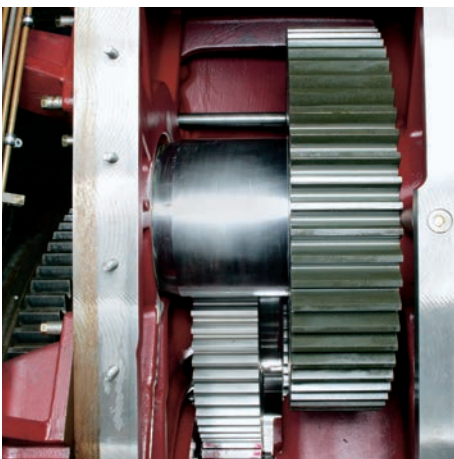

Exhaust gas system

- Good connection conditions at the turbine inlet and, in consequence, optimum incident flow to the turbine
- Single pipe exhaust gas system with gas outlets and cross-sections optimized for efficiency on each cylinder bank

Gearwheel drive

- The symmetrical arrangement of the gearwheels relative to one another permits, by exchanging the intermediate wheel and the stepped wheel, the use of the same camshafts in the case of different engine rotational directions

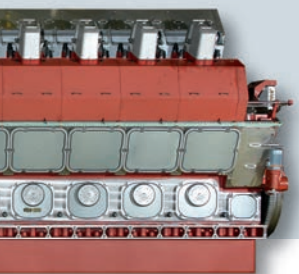
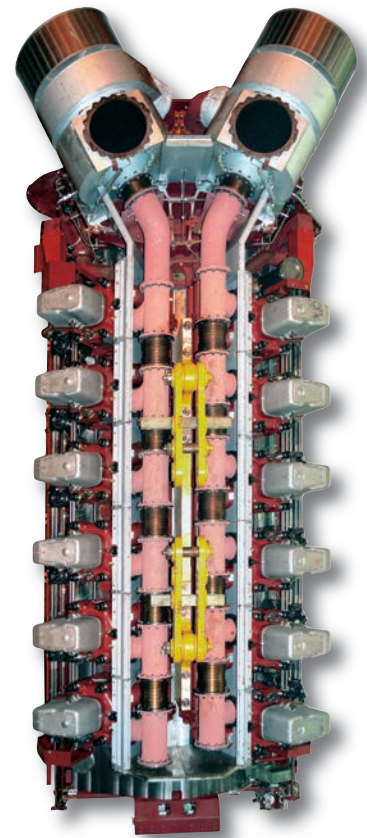

VM 43 C – Design Features

Engine room monitoring

- Oil mist detector in proven technology

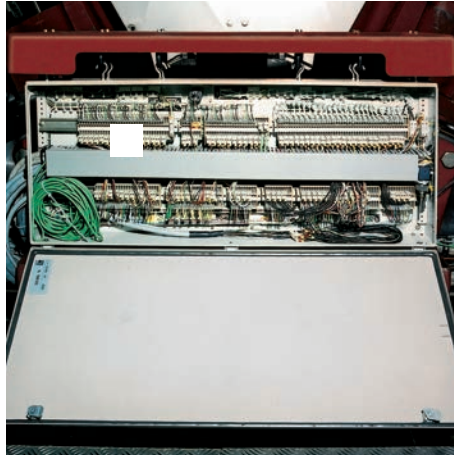

Terminal board

- A terminal board for monitoring and inspection connections with plenty of space for cable connections when alongside

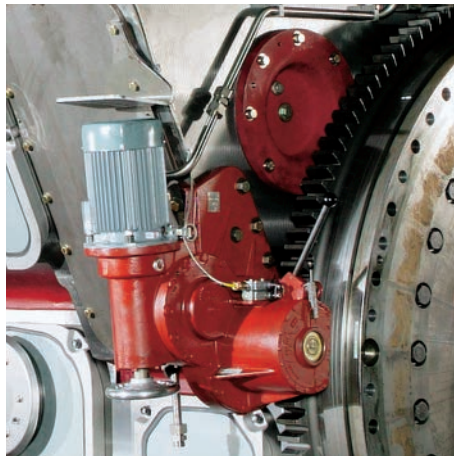
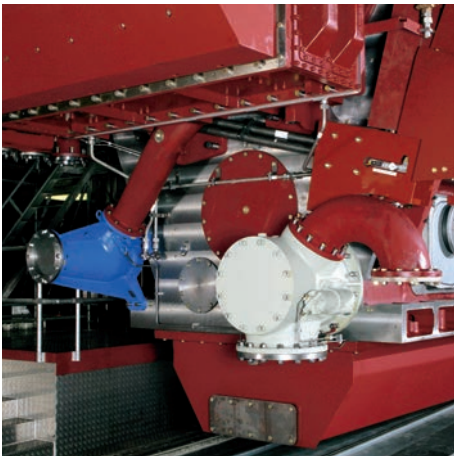

Turning device

- Fastened directly to the engine block in a safe and low vibration manner

Complete engine

- The engine is on offer with a standardized pump and filter attachment

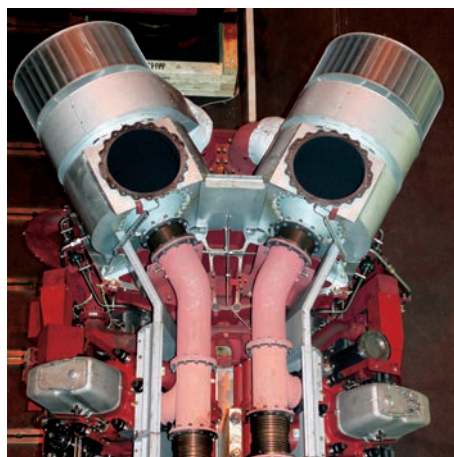

Exhaust ducting connections

- V-position of the turbocharger for small center distance in the case of twin-engine installations
- Vertical exhaust outlets for simple connection to the exhaust gas system

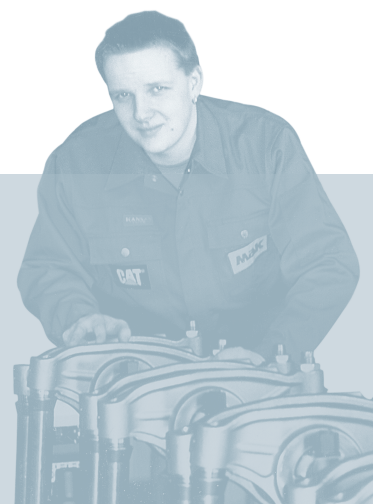

VM 43 C – Economical from Installation to Operation

	TBO x 1000 h	Lifetime x 1000 h
Piston crown	15/30*	90
Piston skirt	-	60
Piston rings	-	30
Cylinder liner	-	60 / 90*
Cylinder head	15	-
Inlet valve	15	30
Exhaust valve	15	30
Nozzle element	-	4/8*
Pump element	-	15 / 20*
Main bearing	-	30
Big-end bearing	-	30

*MDO Operation

The above-mentioned data are not binding. They only serve as standard values. These standard values can be attained if the MaK operating and maintenance specifications are strictly observed and only MaK spare parts are used. Please consider as well the negative effect of bad fuel qualities.



HFO/MDO Anticipated TBO and life

Long maintenance intervals and extended life form the basis for low operating costs.

Complete engine

The engine is marketed with standardized pump and filter equipment. The interfaces for the fuel, lubricating oil and cooling water systems are located at the free end of the engine for ease of connection.

Resilient foundation

The resilient foundation system can be assembled safely, simply and cheaply and ensures the damping of vibration and structure-borne noise.

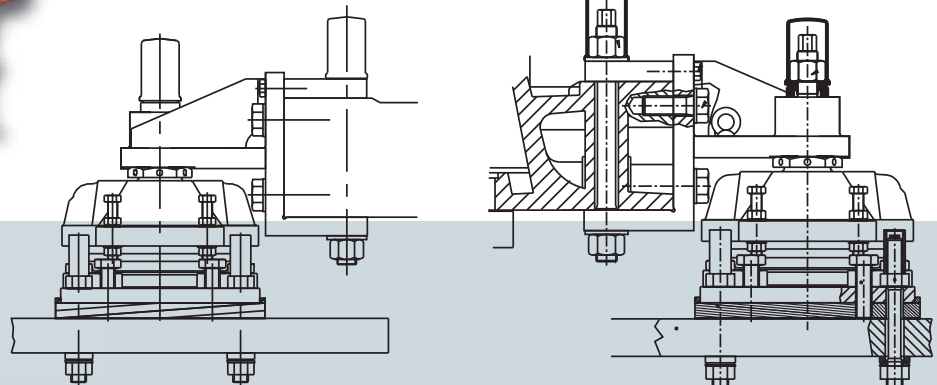
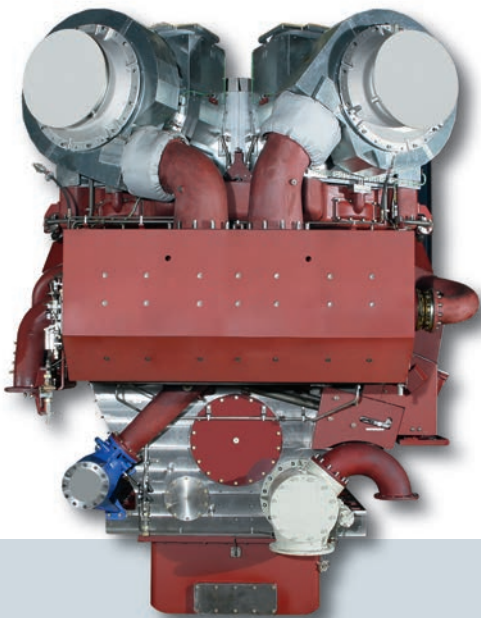

VM 43 C – Emission Reduction Technology

The long-stroke concept for ecological operation

Environmental protection is also becoming increasingly important for seagoing shipping. Caterpillar Motoren recognized this trend in good time and, with the design and development of the modern long-stroke engine concept, created the conditions for engine operation at reduced emission levels. The NO_x emissions of the VM 43 C engine lies well below the International Maritime Organisation's limiting curve.

The long-stroke concept for engine operation at reduced emission levels

The following features characterise the concept which ensures, in addition to smooth running, maximum operational reliability and also permits operation on heavy fuel oil up to 700 cSt/50°C.

- Long piston stroke
- Large stroke/bore ratio
- Intensive injection
- Shaped injection curve
- Optimised control times
- High ignition pressure

For MDO operation the engine is also available with less NO_x emission: Det Norske Veritas DNV "Clean Design" and Federal Ministry of Environment "Blue Angel".

A further step to reduce soot emissions is the introduction of **Caterpillar Common Rail**, where the injection pressure is independent from load and speed. Utilizing several maps the injection characteristics are optimized for every engine operating point.

In general, the Caterpillar Common Rail fuel system enables vessel operation without visible soot throughout the whole operating range.

Key criteria are:

- Compliance with current and future required emission limits for the respective power ranges
- Customer expectations in terms of engine performance, maintenance practices, fuel quality and mode of operation

By adopting well proven elements of this technology for medium-speed engines, it is our goal to meet and exceed customer expectations by maximizing product value through:

- Superior reliability in heavy fuel operation
- Best fuel efficiency in its class
- Lowest engine emissions without additional equipment

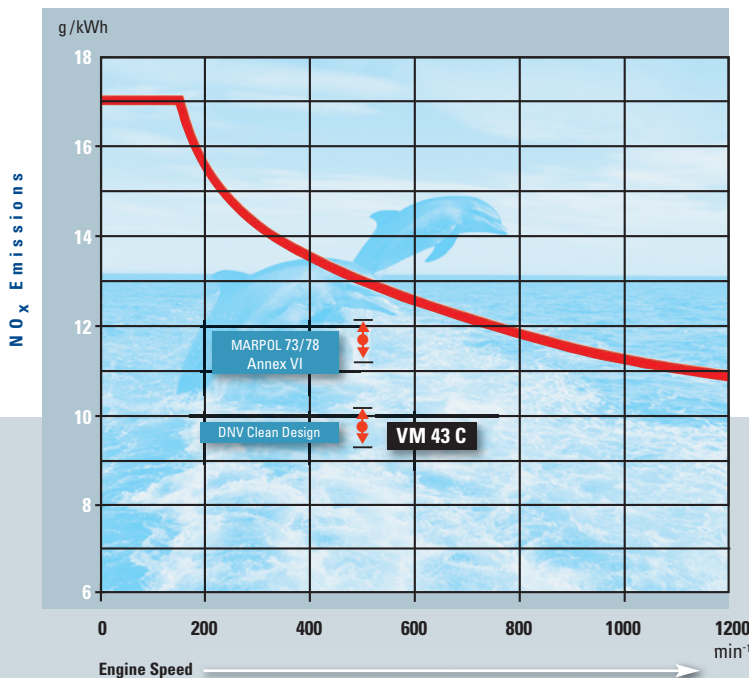
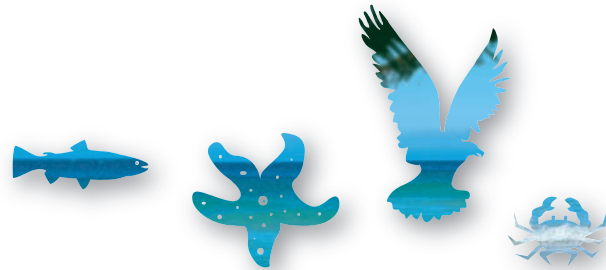

VM43 C – Technical Data

PROPULSION

Type	Output range		Speed rpm	Mean eff. pressure bar	Mean piston Speed m/s	Bore mm	Stroke mm	Spec. fuel consumption	
	kW	mhp						100% g/kWh	85% g/kWh
12 M 43 C	12000	16230	500	27.1	10.2	430	610	176	175
	12000	16230	514	26.4	10.5	430	610	176	175
16 M 43 C	16000	21760	500	27.1	10.2	430	610	176	175
	16000	21760	514	26.4	10.5	430	610	176	175

Specific lubricating oil consumption 0.6 g/kWh, ± 0.3 g/kWh
LCV= 42700 kJ/kg, without engine-driven pumps, tolerance 5%

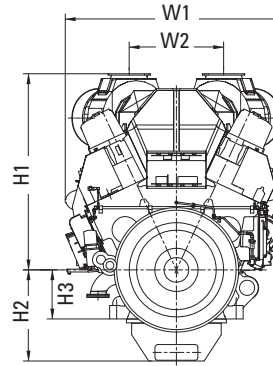
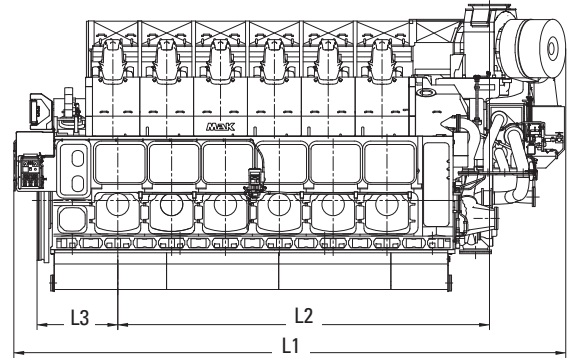

Propulsion engine (Dimensions in mm)									
Engine	L1	L2	L3	H1	H2	H3	W1	W2	Weight (t)
12 M 43 C	8271	1086	1255	1638	3734	1399	750	2878	94.0
16 M 43 C	9068	1119	1255	1704	4105	1399	750	2878	107.0

GENERATING SETS

Type	Engine rating			Mean eff. pressure bar	Mean piston Speed m/s	Spec. fuel consumption	
	kW	kWe	kVA			100% g/kWh	85% g/kWh
12 M 43 C	12000	11520	14400	27.1	10.2	176	175
	12000			26.4	10.5	176	175
16 M 43 C	16000	15360	19000	27.1	10.2	176	175
	16000			26.4	10.5	176	175

Specific lubricating oil consumption 0.6 g/kWh, ± 0.3 g/kWh
LCV= 42700 kJ/kg, without engine-driven pumps, tolerance 5%
Generator efficiency: 0.96. cosφ: 0.8

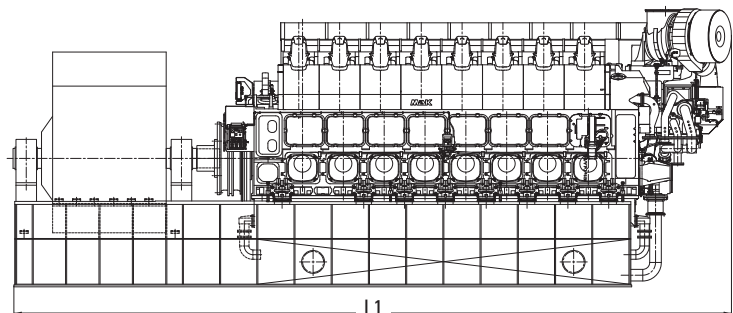
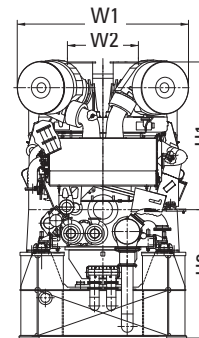

Generating set (Dimensions in mm)						
Engine	L1*	H1	H2	W1	W2	Weight (t)
12 M 43 C	14740	3497	3020	3890	1685	275.0
16 M 43 C	16870	3473	3020	4027	1670	345.0

* Dependent on generator make/type

Cat Financial – World-Class Financing Solutions

You specify Cat or MaK power solutions, because you believe in the power of Caterpillar engines to keep you and your vessel safely on course. Cat Financial has the same commitment to your success – whether you need construction, term or repower financing.

We know how to support customers in one country, construction in a second country and registration in a third. We understand the marine industry – we've been lending to marine customers for more than 20 years. And, as it has been since 1986, our service commitment is powered by Caterpillar and Cat and MaK dealers everywhere.

Global Coverage

Whether you're a German operator building at a Chinese shipyard or a U.S. citizen building a yacht in Italy, Cat Financial can help. Our customers do business around the world, and we support them wherever they go.

Our service commitment extends to all marine sectors. From production and custom yachts to workboats and tankers – we have you covered.

Local Presence

Need a local expert? We know local markets and how to navigate the legal and regulatory environments. Cat Financial has offices in the Americas, Europe and Asia, and financing representatives all over the world. Put our knowledge to work to power the deal.

Get your project moving anywhere in the world with Cat Financial – backed by the power of Caterpillar and our unmatched dealer network.

Visit us online at MARINE.CAT.COM/finance

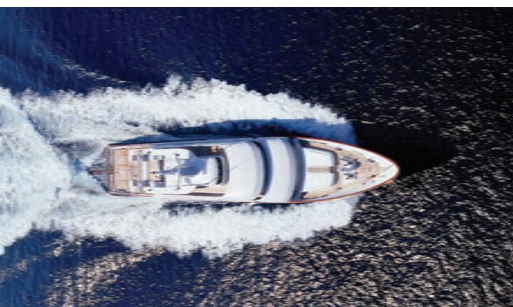

Integrated Solutions – Customer Support Portfolio

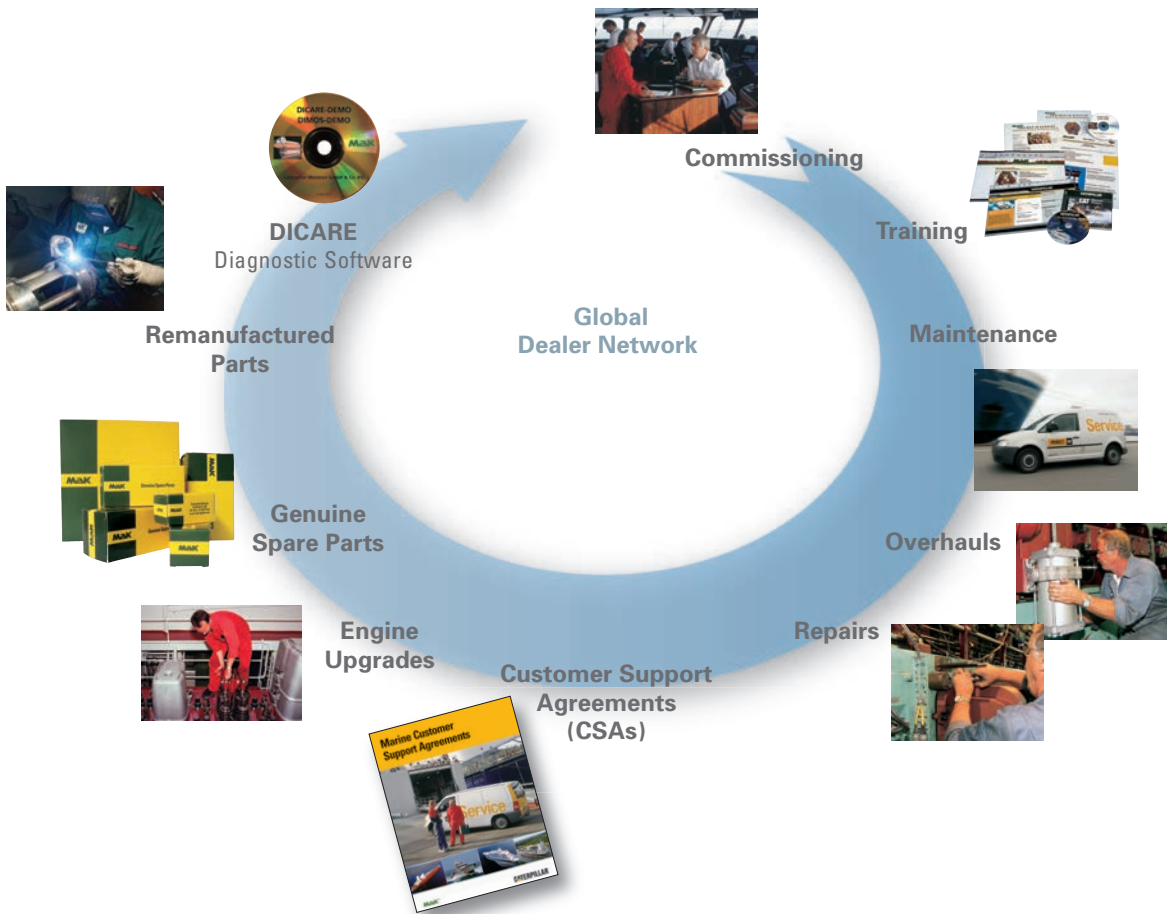

Providing integrated solutions for your power system means much more than just supplying your engines. Beyond complete auxiliary and propulsion power systems, we offer a broad portfolio of customer support solutions and financing options. Our global dealer network takes care of you wherever you are – worldwide. Localized dealers offer on-site technical expertise through marine specialists and an extensive inventory of all the spare parts you might need.

To find your nearest dealer, simply go to:
MARINE.CAT.COM

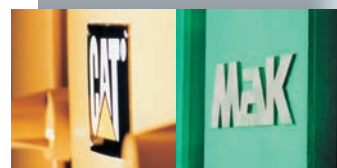

Perfect Solutions for Main Propulsion and On-Board Power Supply

The Program: Quality is our Motto. For more than 90 years we have developed, built, supplied and serviced diesel engines – worldwide. Today Caterpillar Marine with its brands Cat and MaK offer high-speed and medium-speed engines with power ratings from 93 kW to 14,400 kW. Many different engine families are available to meet your specific application needs.

Cat and MaK diesel engines are distinguished by high reliability, extremely low operational costs, simple installation and maintenance and compliance with IMO environmental regulations.

The application of engines in main and auxiliary marine power systems varies greatly and extends from high-speed boats and yachts, through tugs, trawlers and offshore vessels to freighters, ferries and cruise liners.

Sales and Service Organization

Caterpillar has combined the sales and service activities and responsibility of their Cat and MaK brand marine engine business into Caterpillar Marine Power Systems with headquarters in Hamburg/Germany.

In setting-up this worldwide structure, we have concentrated on integrating the Cat and MaK brand groups into a single, united marine team, which utilises the particular expertise of each group.

Commercial marine engine business is split into three geographic regions,

- Europe, Africa, Middle East
- Americas ■ Asia-Pacific,

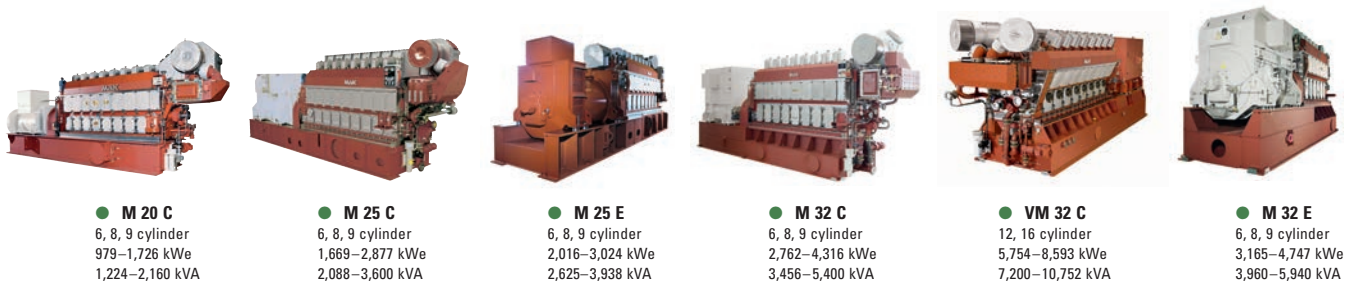

Propulsion Engines

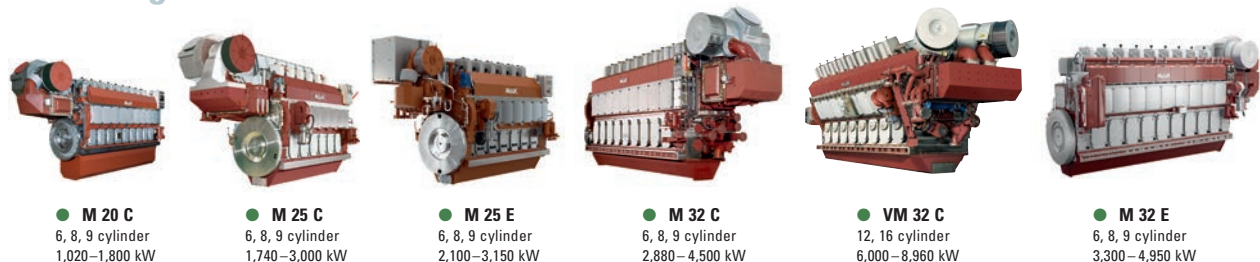

Production Facilities

which manage all sales and product support activities. They have direct responsibility for achieving the ambitious growth targets set for the Cat and MaK brands and for providing our customers and dealers with complete marine solutions.

Caterpillar's global dealer network provides a key competitive edge – customers deal with people they know and trust.

Cat dealers strive to form a strong working relationship with their customers, offering comprehensive and competent advice from project support to repair work.

Some of the most advanced manufacturing concepts are used at Caterpillar locations throughout the world to produce engines in which reliability, economy and performance are second-to-none.

From the production of core components, the assembly of engines to the delivery of complete propulsion packages, quality is always the top priority.

Comprehensive, recognized analysis systems, test procedures and measuring

methods ensure that quality requirements are met throughout all the individual manufacturing phases. All of our production facilities are certified under 1:2000 ISO 9001 EN, the international benchmark that is helping to set new quality standards worldwide.

In addition to product quality, our customers expect comprehensive service which includes the supply of spare parts throughout the life of the engine.



● **C280**
6, 8, 12, 16 cylinder
1,650–5,200 kW
2,063–6,500 kVA

Onboard Power Supply

- High-Speed Engines
- Medium-Speed Engines

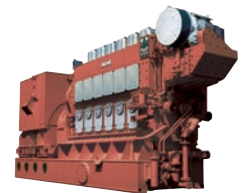

● **M 34 DF**
6, 8, 9 cylinder
2,877–4,316 kW
3,600–5,400 kVA



● **M 43 C**
6, 7, 8, 9 cylinder
5,179–9,063 kW
6,480–11,340 kVA



● **VM 43 C**
12, 16 cylinder
10,357–16,111 kW
12,960–20,160 kVA



● **M 46 DF**
6, 7, 8, 9 cylinder
5,179–7,768 kW
6,480–9,720 kVA



● **VM 46 DF**
12, 16, cylinder
10,357–13,810 kW
12,960–17,280 kVA



● **C32 ACERT**
12 cylinder
492–1,417 kW



● **3500**
8, 12, 16 cylinder
526–2,525 kW



● **C175**
16 cylinder
2,001–2,550 kW



● **C280**
6, 8, 12, 16 cylinder
1,730–5,650 kW

- High-Speed Engines
- Medium-Speed Engines



● **M 34 DF**
6, 8, 9 cylinder
3,000–4,500 kW

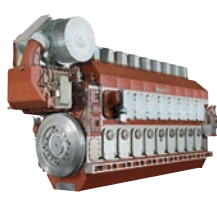

● **M 43 C**
6, 7, 8, 9 cylinder
5,400–9,450 kW

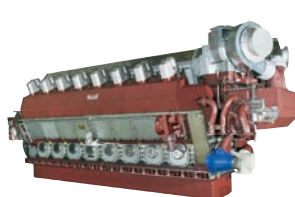

● **VM 43 C**
12, 16 cylinder
10,800–16,800 kW



● **M 46 DF**
6, 7, 8, 9 cylinder
5,400–8,100 kW

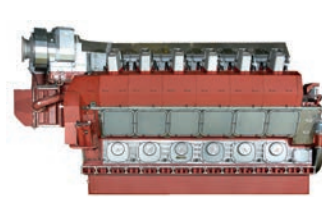

● **VM 46 DF**
12, 16 cylinder
10,800–14,400 kW

The Power You Need.

The Cat® and MaK™ brands of Caterpillar Marine offer premier high- and medium-speed propulsion, auxiliary, and generator set solutions, as well as optional dual fuel, diesel-electric, and hybrid system configurations. With the launch of Caterpillar Propulsion our comprehensive and evolving product line gives customers one source for the most extensive engine power range available, complete propulsion systems, controllable pitch propellers, transverse and azimuth thrusters, and controls. Cat and MaK products and technologies are proven reliable and are built to last in all marine applications, demonstrating superior productivity and the lowest lifecycle cost.

The Cat Global Dealer Network, more than 2,200 global service locations strong, ensures that you'll have local expertise, highly-trained technicians, rapid parts delivery, and the proper equipment and services to keep you working – anytime, anywhere.

Construction, term, or repower financing through Cat Financial helps you make Cat and MaK power a reality. With our knowledge of customer needs, local markets, and legal and regulatory requirements, we've been providing tailored financing solutions and exceeding expectations since our start in 1986.

For more information and to find your local dealer, please visit our website: **MARINE.CAT.COM**

Visit Cat Financial at: **CatPowerFinance.com**

BUILT FOR IT.™

Caterpillar Marine

Europe, Africa, Middle East

Caterpillar Marine
A Division of
Caterpillar Motoren GmbH & Co.KG
Neumühlen 9
22763 Hamburg
Germany

Phone: +49 40 2380 3000
Telefax: +49 40 2380 3535

Americas

MaK Americas Inc.
3450 Executive Way
Miramar Park of Commerce
Miramar, FL. 33025/USA

Phone: +1 954 885 3200
Telefax: +1 954 885 3131

Asia Pacific

**Caterpillar Marine Trading
(Shanghai) Co., Ltd.**
25/F, Caterpillar Marine Center
1319, Yan'an West Road
200050 Shanghai/P. R. China

Phone: +86 21 6226 2200
Telefax: +86 21 6226 4500

**Caterpillar Marine Asia
Pacific Pte Ltd**
No. 5 Tukang
Innovation Grove
Singapore 618304
Republic of Singapore

Phone: +65 68287 600
Telefax: +65 68287 625

Subject to change without notice.
Leaflet No. 241 · 09.14 · e · L+S · VM3
LEDM0047-00

© 2014 CAT, CATERPILLAR, their respective logos, MaK, "Caterpillar Yellow" and the "Power Edge" trade dress, as well as corporate and product identity used herein, are trademarks of Caterpillar and may not be used without permission.



Caterpillar Marine is committed to sustainability. This document is printed on PEFC certified paper

MaK