

323D2 L

Hydraulic Excavator



Engine

Engine Model	Cat® C7.1 ACERT™ engine meets China III Nonroad emission standards	
Engine Power (ISO 14396)	118 kW	158 hp
Net Power (SAE J1349/ISO 9249)	116 kW	156 hp

Weights

Minimum Operating Weight	22 300 kg	49,100 lb
Maximum Operating Weight	23 300 kg	51,370 lb

323D2 L Differentiating Features

Built to Last

Caterpillar design and manufacturing techniques assure you get outstanding durability and service life in the toughest applications.

Fuel Efficient

A powerful Cat C7.1 ACERT engine meets China III Nonroad emission standards combined with a new highly efficient hydraulic system, which delivers excellent performance with lower fuel consumption compared to its predecessor 323D L.

Easy to Operate

The new cab provides you with a comfortable working environment for maximum production and efficiency. The new monitor features a 40% larger and four times increased resolution LCD display, compared to 323D L monitor.

Reduced Service and Maintenance Costs

Routine service and maintenance can be completed quickly and easily to help you reduce ownership costs. Convenient access points, extended service intervals, and advanced filtration help keep downtime to a minimum.

Complete Customer Support

Your Cat dealer offers a wide range of services that can be set up under a customer support agreement when you purchase your equipment.

Contents

Operator Station.....	4
Engine	6
Hydraulics	7
Undercarriage and Structures	8
Front Linkage	9
Work Tools.....	10
Integrated Technologies.....	12
Serviceability.....	13
Complete Customer Care.....	14
Specifications.....	15
Standard Equipment.....	25
Optional Equipment.....	26
Notes.....	27





The 323D2 L incorporates innovations to improve your job site efficiency through low owning and operating costs, excellent performance, and high versatility.

Operator Station

Your operators will enjoy the incredibly comfortable cab.

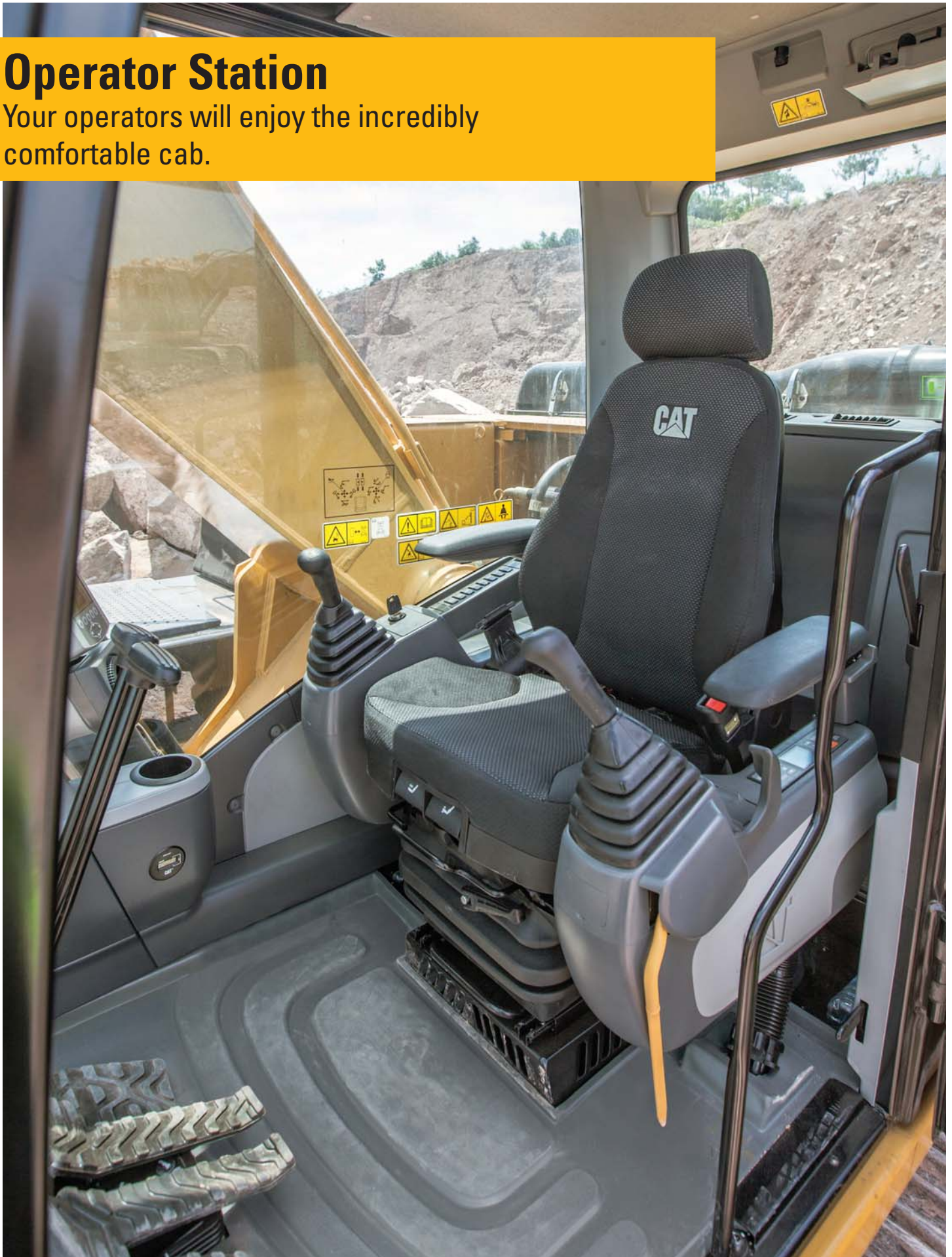

Operator Station

The ergonomically designed operator station is spacious, quiet, and comfortable, assuring high productivity during a long work day. All control switches are located on the right-hand and left-hand side consoles for more convenient access.

Monitor

The monitor is a full-color Liquid Crystal Display (LCD). Monitor is equipped with warning lamp and buzzer for critical engine oil pressure, coolant temperature and oil temperature. Filters and fluid change intervals are available in the main menu. It also projects the image from the optional rearview camera, further enhancing your job site safety and productivity.

Compared to 323D L D Series monitor, the new monitor on 323D2 L has a 40% larger screen, with a four times increased resolution display. Information language capability increased from 28 to 42 languages to support today's diverse workforce.

Seat

The mechanical or air suspension seats provide a variety of adjustments to accommodate a wide range of operators. All seats include a reclining back, upper and lower seat slide adjustments, and height and tilt adjustments.

Controls

Your operators can adjust the right and left joysticks for individual preferences, helping the operator become more comfortable, more productive, and more alert. Low-effort pilot-operated joystick controls are designed to match your natural wrist and arm position for maximum comfort and minimum fatigue.

Climate Control

The 323D2 L offers positive filtered ventilation with a pressurized cab. Fresh air or re-circulated air can be selected, which makes working in the heat and cold much more pleasant.

Cab Structure and Mounts

The cab shell is attached to the frame with viscous rubber cab mounts, which dampen vibrations and sound levels while enhancing operator comfort. Thick steel tubing along the bottom perimeter of the cab, improves resistance to fatigue and vibration.

Windows

To maximize visibility, all glass is affixed directly to the cab, eliminating window frames. The upper front windshield opens, closes, and stores on the roof above the operator with a one-touch action release system.



Engine

You can count on reliable performance to meet your demanding needs all day long.



Reliable Cat C7.1 Engine

The Cat C7.1 ACERT electronic controlled engine has been designed to meet China III Nonroad emission standards. The C7.1 engines incorporate proven, robust components and precision manufacturing you can count on for reliable and efficient operation. This is a proven engine that boasts improved reliability, as it's less sensitive to low quality fuel and also delivers better fuel consumption. An ECO-mode feature helps to reduce fuel consumption by up to 15% for fuel-conscious customers.

Automatic Engine Speed Control

Automatic engine speed control is activated during no-load or light-load conditions which reduces engine speed to minimize fuel consumption.

Air Cleaner and Air Precleaner

The radial seal air filter features a double-layered filter core for more efficient filtration and is located in a compartment behind the cab. A warning is displayed on the monitor when dust accumulates above a preset level. Air precleaner reduces the amount of dust and debris that enter the air intake system which can help maximize engine performance by extending air filter life.

Filtration System

The C7.1 engine features an improved filtration system to ensure good reliability to fuel injection system components. Intervals have been extended and the number of filters reduced to maximize your profit potential.

Hydraulics

You can move dirt, rock and debris with speed, precision and efficiency.



Hydraulic System

The hydraulic cross-sensing system utilizes each of two hydraulic pumps to 100% of engine power under all operating conditions. This improves productivity with faster implement speeds and quicker, stronger pivot turns. Snubbers are located at the rod-end of the boom cylinders and both ends of the stick cylinders to cushion shocks while reducing sound levels and extending component life. The hydraulic activation lever in the neutral position isolates all front linkage, swing, and travel functions for additional controllability and efficiency.

Optional auxiliary control circuits allow operation of high- and medium-pressure tools such as shears, grapples, hammers, pulverizers, multi-processors, and vibratory plate compactors.

Component Layout

The 323D2 L hydraulic system and component locations have been designed to provide a high level of system efficiency. The main pumps, control valves, and hydraulic tank are located close together to allow for shorter tubes and lines between components, which reduce friction loss and pressure drops.

Boom and Stick Regeneration Circuit

Electric boom and stick regeneration circuits result in less pressure loss, higher controllability, reduced cycle times, more productivity and lower operating costs for you. It works by reusing the flow of oil that travels from the head of cylinder to the rod end of cylinder during your boom-down and stick-in operations.

Undercarriage and Structures

Strong and durable, all you expect from Cat excavators.



Undercarriage

The long (L) wide and sturdy undercarriage maximizes stability and lift capacity.

The X-shaped, box-section carbody provides excellent resistance to torsional bending. Robot-welded track roller frames are press-formed, pentagonal units to deliver exceptional strength and service life.

Sealed and lubricated heavy duty track rollers, carrier rollers, and idlers provide excellent service life to keep your machine in the field and working longer.

Frame

You can expect excellent quality, reliability and durability with the 323D2 L lower and upper frames. Both are built to handle a hard day's work over and over again.

Front Linkage

You will experience a long service life even in the harshest of conditions.



Cat front linkages are designed for maximum versatility, productivity, and high efficiency whatever the application.

Heavy-Duty Front Linkage

The 5.7 m (18'8") heavy-duty (HD) reach boom is reinforced to be used in the severest applications and provide maximum digging capability. Heavy-duty Reach boom is made of high-tensile-strength steel using a large box-section design with interior baffle plates and an additional bottom guard for long life and durability.

The HD reach boom has two stick options available to meet all your application requirements.

The 2.9 m (9'6") stick is the most versatile option and a very good fit for truck loading and trenching applications where you need additional working range.

The 2.5 m (8'2") stick is ideally suited to applications requiring larger bucket sizes. It maximizes digging forces and enables you to get your jobs completed faster.

Work Tools

Dig, hammer, rip, and cut with confidence.

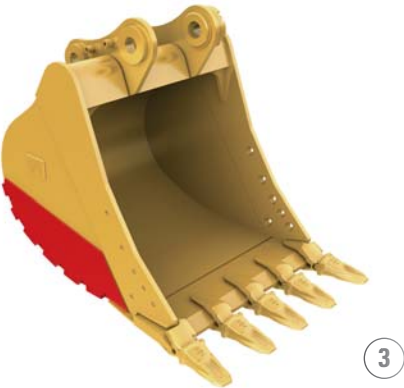
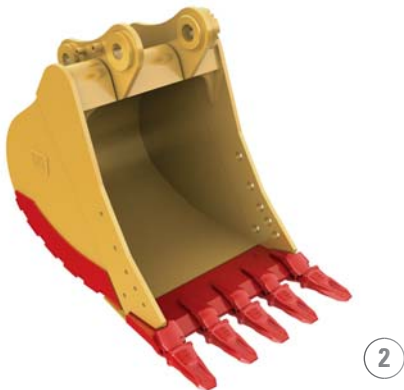

Each Cat work tool attachment is designed to optimize the versatility and performance of your machine. An extensive range of buckets, compactors, grapples, multi processors, rippers, crushers, pulverizers, hammers, and shears are available for your 323D2 L. Contact your local Cat dealer for more information on the attachments available in your region.

Buckets

Cat buckets and Cat Ground Engaging Tools (GET) are designed and matched to the machine to ensure optimal performance and fuel efficiency.

1 – General Duty Buckets (GD)

These buckets are designed for digging in low-impact, moderately abrasive materials such as dirt, loam, gravel, and clay.

2 – Heavy Duty Buckets (HD)

HD buckets are a good starting point when application conditions vary. Especially when conditions include mixed dirt, clay, sand, and gravel.

3 – Severe Duty Buckets (SD)

These buckets are best suited to highly abrasive applications such as shot rock, sand stone, and granite.

Couplers

Quick couplers allow one person to change work tools in seconds for maximum performance and flexibility on a job site. One machine can move rapidly from task to task, and a fleet of similarly equipped machines can share a common work tool inventory.

E Series Hammers

E Series hammers bring together customer expectations of performance, quality, and serviceability along with Caterpillar manufacturing and logistics experience.

E Series hammers are quiet, and noise suppression is valuable in urban and restricted work areas.

Grapples

Cat grapples replace the bucket on Cat excavators, converting them to the ideal machine for handling loose material, sorting trash, and demolition site cleanup. An array of styles and sizes are available to match excavators to the task at hand.

Multi-Processors

Multi-processors do the work of many types of demolition tools by use of interchangeable jaw sets. Changing jaws allows a single unit to crush, pulverize, and perform a variety of specialized cutting tasks such as cutting steel rebar and tanks.

Shear

Cat shears are designed for Cat machines – taking full advantage of the hydraulic flows and pressures to enhance productivity without compromising safety or causing premature wear of the shear and carrier.

Pulverizer

The excavator mounted mechanical pulverizer is a cost-effective tool for recycling demolished concrete debris. The bucket cylinder on the excavator powers the mechanical pulverizer. This eliminates the need for a dedicated cylinder and associated hydraulics and additional installation cost.

Vibratory Plate Compactor

Compactors enhance the versatility of your excavator and makes compacting faster, more efficient, and cost-effective. Cat compactors are the superior choice for any job site's compaction tasks.

Crusher

The hydraulic concrete crusher has taken modern demolition technology a step further. It is well suited for concrete demolition in residential areas. The hydraulic concrete crusher combines several concrete demolition operations in one piece of equipment:

- breaking out concrete from fixed structures
- pulverizing concrete
- cutting reinforcement rods and small steel profiles



Integrated Technologies

You can make your team's work much easier and more efficient.



Cat Product Link™

You can monitor and improve your fleet management with Cat Product Link. The integrated system reports events, diagnostic codes, hours, fuel consumption, location, and other pieces of detailed machine information to the secured web-based application called VisionLink®. The powerful tools within VisionLink communicate with you and your authorized Cat dealer to allow them to help you avoid downtime and better maintain your fleet.



Serviceability

You can depend on safe, fast, and easy access.



Ground-Level Service

The design and layout of the 323D2 L was made with the service technician in mind. Most service locations are easily accessible at ground level to allow service and maintenance to get completed quickly and efficiently.

Air Filter Compartment

The air filter features a double-element construction for superior cleaning efficiency. When the air filter plugs, a warning is displayed on the cab monitor. Maintenance free batteries are standard along with a battery disconnect switch.

Pump Compartment

A service door on the right side of the upper structure allows ground-level access to the hydraulic pumps, hydraulic filters, engine oil filter, and fuel filters.

Radiator Compartment

The left rear service door allows easy access to the engine radiator, hydraulic oil cooler, air-to-air aftercooler, and AC condenser. A reserve tank and drain cock are attached to the radiator for ground level maintenance.

Greasing Points

A concentrated remote greasing block on the boom allows the greasing of hard-to-reach locations on the boom and stick.

Fan Guard

The engine radiator fan is enclosed by a steel guard that provides maximum protection when carrying out routine service and maintenance.

Anti-Skid Plate

Anti-skid plating covers the entire upper structure and storage box to prevent slipping during maintenance. Safety is further enhanced with the addition of countersunk bolts to reduce trip hazards.

Diagnostics and Monitoring

The 323D2 L is equipped with Scheduled Oil Sampling (S-O-SSM) ports for the hydraulic system, engine oil, and coolant. Standard hydraulic test ports enable a service technician to quickly and easily fault find in the event of service issue.

Complete Customer Care

Your Cat dealer will support you like no other.



Product Support

You can maximize your machines' uptime with the Cat worldwide dealer network. You can also decrease your repair costs by utilizing Cat remanufactured components while contributing to sustainable development.

Machine Selection

What are the job requirements and machine attachments? What production do you need? Your Cat dealer can provide recommendations to help you make the right machine configuration.

Purchase

You can ensure lower owning and operating costs by utilizing unique Cat dealer services and financing options.

Customer Support Agreements

Cat dealers offer a variety of customer support agreements and work with you to develop a plan to meet your specific needs. These plans can cover the entire machine, including attachments, to help protect your investment.

Operation

You can boost your profits by improving your operators' techniques. Your Cat dealer has videos, literature, and other ideas to help increase productivity. Caterpillar also offers simulators and certified operator training to help maximize the return on your investment.

Replacement

Repair, rebuild, or replace? Your Cat dealer can help you evaluate the cost involved so you can make the best choice for your business.

Engine

Engine Model	Cat C7.1 ACERT	
Engine Power – ISO 14396	118 kW	158 hp
Net Power – SAE J1349/ISO 9249	116 kW	156 hp
Bore	105 mm	4.13 in
Stroke	135 mm	5.31 in
Displacement	7.01 L	428 in ³

- The Cat C7.1 meets China III Nonroad emission standards.
- Net power advertised is the power available at the flywheel when the engine is equipped with fan, air cleaner, muffler and alternator.
- The field-proven C7.1 engine can work efficiently at altitudes up to 5000 m (16,405 ft).

Swing Mechanism

Swing Speed	10.5 rpm	
Swing Torque	61.8 kN·m	45,581 lbf-ft

Drive

Maximum Travel Speed	5.6 km/h	3.5 mph
Drawbar Pull	205 kN	46,086 lbf

Hydraulic System

Main System – Maximum Flow at Travel	214×2 L/min	56.5×2 gal/min
Main System – Maximum Flow at Operation	202×2 L/min	53.4×2 gal/min
Swing System – Maximum Flow	202 L/min	53.4 gal/min
Maximum Pressure – Equipment	35,000 kPa	5,076 psi
Maximum Pressure – Travel	35,000 kPa	5,076 psi
Maximum Pressure – Swing	25,000 kPa	3,626 psi
Pilot System – Maximum Flow	23.1 L/min	6.1 gal/min
Pilot System – Maximum Pressure	3920 kPa	569 psi
Boom Cylinder – Bore	120 mm	4.7 in
Boom Cylinder – Stroke	1260 mm	49.6 in
Stick Cylinder – Bore	140 mm	5.5 in
Stick Cylinder – Stroke	1504 mm	59.2 in
B1 Bucket Cylinder – Bore	120 mm	4.7 in
B1 Bucket Cylinder – Stroke	1104 mm	43.5 in

Service Refill Capacities

Fuel Tank Capacity	410 L	108 gal
Cooling System	25 L	6.6 gal
Engine Oil	22 L	5.8 gal
Swing Drive	8 L	2.1 gal
Final Drive (each)	10 L	2.6 gal
Hydraulic System Oil Capacity (including tank)	260 L	68.7 gal
Hydraulic Oil	138 L	36.5 gal

323D2 L Specifications

Dimensions

All dimensions are approximate.

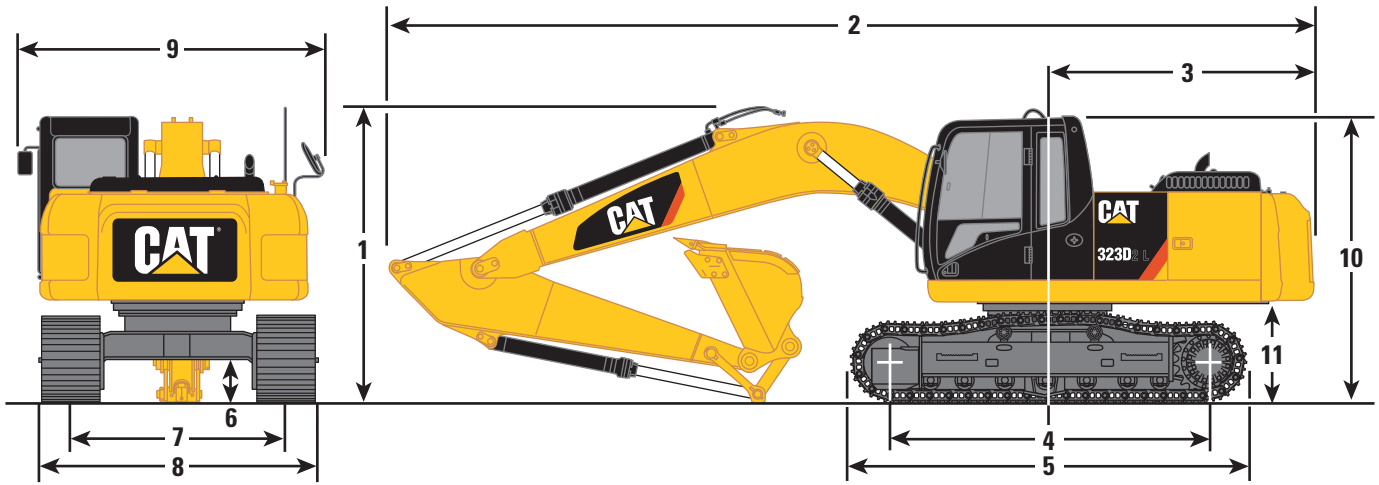

HD Reach Boom 5.7 m (18'8")

	HD R2.9B1 (9'6")	HD R2.5B1 (8'2")
1 Overall Height*	3030 mm (9'11")	3050 mm (10'0")
2 Overall Length	9460 mm (31'0")	9460 mm (31'0")
3 Tail Swing Radius	2750 mm (9'0")	2750 mm (9'0")
4 Length to Center of Rollers	3650 mm (12'0")	3650 mm (12'0")
5 Track Length	4455 mm (14'7")	4455 mm (14'7")
6 Ground Clearance**	450 mm (1'6")	450 mm (1'6")
7 Track Gauge	2380 mm (7'10")	2380 mm (7'10")
8 Transport Width		
600 mm (24") Shoes	2980 mm (9'9")	2980 mm (9'9")
790 mm (31") Shoes	3170 mm (10'5")	3170 mm (10'5")
9 Width of Upper Structure	2740 mm (9'0")	2740 mm (9'0")
10 Cab Height*	2950 mm (9'8")	2950 mm (9'8")
11 Counterweight Clearance**	1020 mm (3'4")	1020 mm (3'4")
Bucket Type	HD	HD
Bucket Capacity	1.19 m ³ (1.56 yd ³)	1.19 m ³ (1.56 yd ³)
Bucket Tip Radius	1570 mm (5'2")	1570 mm (5'2")

*Including shoe lug height.

**Without shoe lug height.

Working Ranges

All dimensions are approximate.

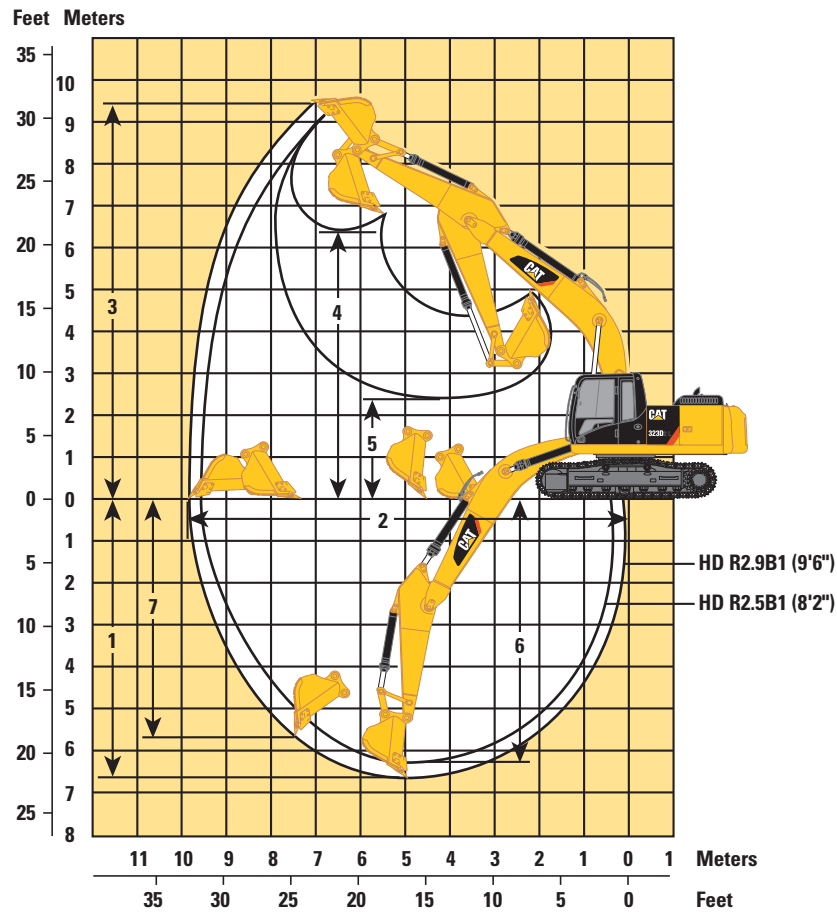

HD Reach Boom 5.7 m (18'8")

	HD R2.9B1 (9'6")	HD R2.5B1 (8'2")
1 Maximum Digging Depth	6720 mm (22'1")	6300 mm (20'8")
2 Maximum Reach at Ground Level	9860 mm (32'4")	9630 mm (31'7")
3 Maximum Cutting Height	9490 mm (31'0")	9290 mm (30'6")
4 Maximum Loading Height	6490 mm (21'4")	6290 mm (20'8")
5 Minimum Loading Height	2170 mm (7'1")	2590 mm (8'6")
6 Maximum Depth Cut for 2440 mm (8'0") Level Bottom	6380 mm (20'11")	5960 mm (19'7")
7 Maximum Vertical Wall Digging Depth	5690 mm (18'8")	5650 mm (18'6")
Bucket Type	HD	HD
Bucket Capacity	1.19 m ³ (1.56 yd ³)	1.19 m ³ (1.56 yd ³)
Bucket Tip Radius	1570 mm (5'2")	1570 mm (5'2")

323D2 L Specifications

Operating Weight* and Ground Pressure

The standard and optional equipment availability vary by region. Please contact your local Cat dealer for more information about the work tools available in your region.

Operating Weight				
	Bucket Capacity	600 mm (24") Triple Grouser Shoes	790 mm (31") Triple Grouser Shoes	600 mm (24") Double Grouser Shoes
Reach Boom – HD – 5.7 m (18'8")				
R2.9 HD (9'6")	1.19 m ³ (1.56 yd ³)	22 400 kg (49,270 lb)	23 000 kg (50,680 lb)	22 700 kg (50,110 lb)
R2.5 HD (8'2")	1.19 m ³ (1.56 yd ³)	22 300 kg (49,120 lb)	22 900 kg (50,530 lb)	22 700 kg (49,960 lb)
Ground Pressure				
	Bucket Capacity	600 mm (24") Triple Grouser Shoes	790 mm (31") Triple Grouser Shoes	600 mm (24") Double Grouser Shoes
Reach Boom – HD – 5.7 m (18'8")				
R2.9 HD (9'6")	1.19 m ³ (1.56 yd ³)	46.5 kPa (6.7 psi)	36.3 kPa (5.3 psi)	47.3 kPa (6.9 psi)
R2.5 HD (8'2")	1.19 m ³ (1.56 yd ³)	46.3 kPa (6.7 psi)	36.2 kPa (5.3 psi)	47.1 kPa (6.8 psi)

*Based on ISO 6016. Operating weight includes Base machines with fronts, bucket, full fuel tank and fluids, and 75 kg (165 lb) operator, excluding optional attachments.

Major Component Weights

Base Machine (with counterweight 4.26 mt/9,390 lb, with boom cylinders, without front linkage, without tracks)	15 410 kg (33,970 lb)
Counterweight	4260 kg (9,390 lb)
Upper Frame	6320 kg (13,930 lb)
Undercarriage	4490 kg (9,900 lb)
Full Fuel	340 kg (750 lb)
Boom (includes lines, pins, and stick cylinder)	
Heavy Duty Reach Boom – 5.7 m (18'8")	2010 kg (4,430 lb)
Stick (includes lines, pins, linkage and bucket cylinder)	
R2.9 HD (9'6")	1120 kg (2,470 lb)
R2.5 HD (8'2")	1050 kg (2,310 lb)
Long Tracks Shoes	
600 mm (24") Triple Grouser	2700 kg (5,950 lb)
600 mm (24") Double Grouser	3080 kg (6,790 lb)
790 mm (31") Triple Grouser	3350 kg (7,390 lb)
Buckets	
1200 mm (47")/1.19 m ³ (1.56 yd ³)	1030 kg (2,270 lb)
1350 mm (53")/1.38 m ³ (1.80 yd ³)	1090 kg (2,400 lb)

Bucket and Stick Forces

	Reach Boom – HD 5.7 m (18'8")	
	HD R2.9B1 (9'6")	HD R2.5B1 (8'2")
Bucket	1.19 m ³ (1.56 yd ³)	1.19 m ³ (1.56 yd ³)
Bucket Digging Force (ISO)	140 kN (31,472 lbf)	140 kN (31,506 lbf)
Stick Digging Force (ISO)	107 kN (24,054 lbf)	118 kN (26,549 lbf)
Bucket Digging Force (SAE)	125 kN (28,100 lbf)	125 kN (28,024 lbf)
Stick Digging Force (SAE)	104 kN (23,379 lbf)	114 kN (25,717 lbf)

323D2 L Specifications

323D2 L Bucket Specifications and Compatibility

	Linkage	Width		Capacity		Weight		Fill	Reach Boom		
		mm	in	m ³	yd ³	kg	lb		%	HD R5.7 (18'8")	
										HD R2.9B1 (9'6")	
									600 mm (24") Tracks	790 mm (31") Tracks	
Without Quick Coupler											
General Duty (GDC)	B	600	24	0.55	0.72	619	1,363	100	●	●	
	B	750	30	0.75	0.98	710	1,566	100	●	●	
	B	900	36	0.95	1.24	787	1,735	100	●	●	
	B	1050	42	1.16	1.52	848	1,870	100	⊖	⊖	
	B	1200	48	1.38	1.80	926	2,041	100	○	○	
General Duty – CCL	B	1350	54	1.59	2.08	1004	2,213	100	◇	○	
	B	1150	46	0.90	1.18	719	1,585	100	●	●	
	B	1250	50	1.00	1.31	751	1,656	100	●	●	
	B	1150	46	0.90	1.18	762	1,680	100	●	●	
	B	1250	50	1.00	1.31	797	1,756	100	⊖	●	
Heavy Duty – China	B	1400	56	1.14	1.49	863	1,902	100	⊖	⊖	
	B	1050	43	1.00	1.31	879	1,937	100	⊖	⊖	
	B	1200	49	1.19	1.56	942	2,076	100	⊖	⊖	
Severe Duty – China	B	1350	54	1.38	1.81	1003	2,210	100	○	○	
	B	1100	43	1.00	1.31	969	2,136	90	⊖	●	
	B	1250	49	1.19	1.56	1068	2,355	90	⊖	⊖	
	CB	1250	50	1.33	1.74	1261	2,778	90			
Maximum load pin-on (payload + bucket)								kg	2755	2850	
								lb	6,072	6,281	

The above loads are in compliance with hydraulic excavator standard EN474, they do not exceed 87% of hydraulic lifting capacity or 75% of tipping capacity with front linkage fully extended at ground line with bucket curled.

Capacity based on ISO 7451.

Bucket weight with General Duty tips.

Maximum Material Density:

- 2100 kg/m³ (3,500 lb/yd³)
- ⊖ 1800 kg/m³ (3,000 lb/yd³)
- 1200 kg/m³ (2,000 lb/yd³)
- ◇ 900 kg/m³ (1,500 lb/yd³)

323D2 L Bucket Specifications and Compatibility

	Linkage	Width		Capacity		Weight		Fill	Reach Boom		
		mm	in	m ³	yd ³	kg	lb		%	HD R5.7 (18'8")	
										600 mm (24") Tracks	790 mm (31") Tracks
With Center-Lock Coupler											
General Duty (GDC)	B	600	24	0.55	0.72	619	1,363	100	●	●	
	B	750	30	0.75	0.98	710	1,566	100	●	●	
	B	900	36	0.95	1.24	787	1,735	100	⊖	⊖	
	B	1050	42	1.16	1.52	848	1,870	100	○	○	
	B	1200	48	1.38	1.80	926	2,041	100	◇	◇	
	B	1350	54	1.59	2.08	1004	2,213	100	X	◇	
Heavy Duty (HD)	B	600	24	0.46	0.61	649	1,431	100	●	●	
	B	750	30	0.64	0.84	748	1,649	100	●	●	
	B	900	36	0.81	1.06	826	1,821	100	⊖	⊖	
	B	1050	42	1.00	1.31	880	1,940	100	⊖	⊖	
	B	1200	48	1.19	1.56	907	1,999	100	○	○	
	B	1200	48	1.19	1.56	918	2,024	100	○	○	
	B	1200	48	1.19	1.56	972	2,141	100	○	○	
	B	1300	52	1.30	1.71	962	2,120	100	◇	◇	
	B	1350	54	1.38	1.81	1054	2,322	100	◇	◇	
Severe Duty (SD)	B	600	24	0.46	0.61	694	1,530	90	●	●	
	B	750	30	0.64	0.84	802	1,768	90	●	●	
	B	900	36	0.81	1.06	889	1,959	90	⊖	●	
	B	1050	42	1.00	1.31	964	2,125	90	⊖	⊖	
	B	1200	48	1.19	1.56	1053	2,320	90	○	○	
	B	1200	48	1.19	1.56	1001	2,207	90	○	○	
	CB	1350	54	1.56	2.04	1249	2,753	90			
Maximum load with coupler (payload + bucket)								kg	2345	2440	
								lb	5,169	5,378	
With Quick Coupler (CW40, CW40s)											
General Duty (GD)	B	600	24	0.46	0.61	503	1,109	100	●	●	
	B	750	30	0.64	0.84	588	1,297	100	●	●	
	B	900	36	0.81	1.06	655	1,444	100	●	●	
	B	1200	48	1.19	1.56	770	1,697	100	⊖	⊖	
	B	1300	51	1.30	1.71	801	1,765	100	○	○	
	B	1400	55	1.43	1.87	837	1,845	100	○	○	
Heavy Duty (HD)	B	600	24	0.46	0.61	584	1,288	100	●	●	
	B	1200	48	1.19	1.56	874	1,927	100	○	⊖	
	B	1300	52	1.30	1.71	929	2,048	100	○	○	
Maximum load with coupler (payload + bucket)								kg	2503	2598	
								lb	5,517	5,726	

The above loads are in compliance with hydraulic excavator standard EN474, they do not exceed 87% of hydraulic lifting capacity or 75% of tipping capacity with front linkage fully extended at ground line with bucket curled.

Capacity based on ISO 7451.

Bucket weight with General Duty tips.

Maximum Material Density:

- 2100 kg/m³ (3,500 lb/yd³)
- ⊖ 1800 kg/m³ (3,000 lb/yd³)
- 1200 kg/m³ (2,000 lb/yd³)
- ◇ 900 kg/m³ (1,500 lb/yd³)
- ⊖ 1500 kg/m³ (2,500 lb/yd³)
- X Not recommended

323D2 L Specifications

323D2 L Work Tool Offering Guide*

Boom Type	Reach HD	
	R2.9 HD	R2.5 HD
Hydraulic Hammer	H120Es H130Es	H120Es H130Es
Multi-Processor	MP15 CC Jaw** MP15 CR Jaw** MP15 PP Jaw*** MP15 PS Jaw** MP15 S Jaw	MP15 CC Jaw MP15 CR Jaw MP15 PP Jaw ^ MP15 PS Jaw MP15 S Jaw
Crusher	P315**	P315
Pulverizer	P215	P215
Demolition and Sorting Grapple	G315B**	G315B G320B*** #
Mobile Scrap and Demolition Shear	S320B*** S325B##	S320B S325B##
Compactor (Vibratory Plate)	CVP110	CVP110
Contractors' Grapple	G120B-G130B	G120B-G130B
Trash Grapple		
Thumbs		
Orange Peel Grapples		
Rakes		
Center-Lock Pin Grabber Coupler		
Dedicated Quick Coupler		

These work tools are available for the 323D2 L.
Consult your Cat dealer for proper match.

* Offerings not available in all areas. Matches are dependent on excavator configurations. Consult your Cat dealer for proper work tool match.

** Pin-on or CW coupler

*** Pin-on only









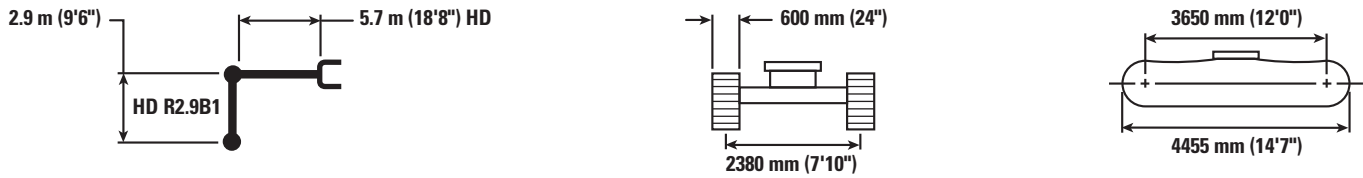

Over the front only

Boom mount

^ Over the front only with CL coupler

323D2 L Heavy Duty Reach Boom Lift Capacities – Long Undercarriage



		1.5 m/5.0 ft		3.0 m/10.0 ft		4.5 m/15.0 ft		6.0 m/20.0 ft		7.5 m/25.0 ft		 m ft		
														
7.5 m 25.0 ft	kg lb							*4600	*4600			*4000 *8,850	*4000 *8,850	6.15 20.00
6.0 m 20.0 ft	kg lb							*4950 *10,900	*4950 *10,900			*3700 *8,150	*3700 *8,150	7.29 24.20
4.5 m 15.0 ft	kg lb							*5450 *11,850	5250 11,250	*5100 *11,200	3650 7,800	*3600 *7,950	3300 7,250	7.99 26.70
3.0 m 10.0 ft	kg lb					*8000 *17,200	7600 16,400	*6250 *13,550	4950 10,700	*5450 *11,850	3550 7,600	*3700 *8,100	3000 6,550	8.36 27.50
1.5 m 5.0 ft	kg lb					*9650 *20,800	7050 15,150	*7100 *15,350	4700 10,100	5400 11,650	3400 7,350	*3900 *8,600	2850 6,300	8.45 28.30
0 m 0 ft	kg lb			*6350 *14,600	*6350 *14,600	*10 550 *22,850	6700 14,450	7400 15,850	4500 9,700	5300 11,400	3300 7,100	*4350 *9,550	2900 6,350	8.26 27.50
-1.5 m -5.0 ft	kg lb	*6800 *15,150	*6800 *15,150	*11 000 *25,000	*11 000 *25,000	*10 650 *23,050	6600 14,250	7300 15,650	4400 9,500	5250 11,350	3300 7,050	5000 11,050	3150 6,900	7.78 25.80
-3.0 m -10.0 ft	kg lb	*11 700 *26,200	*11 700 *26,200	*14 100 *30,550	13 000 27,800	*9950 *21,500	6700 14,350	7300 15,750	4450 9,600			5950 13,150	3700 8,150	6.95 23.30
-4.5 m -15.0 ft	kg lb			*11 200 *23,950	*11 200 *23,950	*8050 *17,100	6900 14,900					*6050 *13,300	5100 11,500	5.60 18.30



ISO 10567



*Indicates that the load is limited by hydraulic lifting capacity rather than tipping load. The above loads are in compliance with hydraulic excavator lift capacity standard ISO 10567:2007. They do not exceed 87% of hydraulic lifting capacity or 75% of tipping load. Weight of all lifting accessories must be deducted from the above lifting capacities. Lifting capacities are based on the machine standing on a firm, uniform supporting surface. The use of a work tool attachment point to handle/lift objects, could affect the machine lift performance.









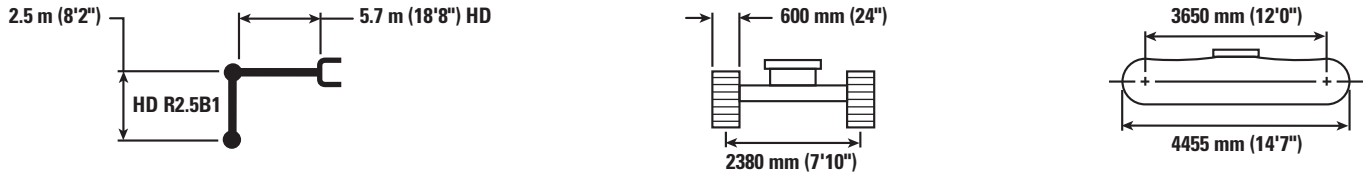



Lift capacity is for "Heavy Lift" mode, without bucket. Lift capacity stays with $\pm 5\%$ for all available track shoes.

Always refer to the appropriate Operation and Maintenance Manual for specific product information.

323D2 L Specifications

323D2 L Heavy Duty Reach Boom Lift Capacities – Long Undercarriage



		1.5 m/5.0 ft		3.0 m/10.0 ft		4.5 m/15.0 ft		6.0 m/20.0 ft		7.5 m/25.0 ft				m ft
														
7.5 m 25.0 ft	kg lb											*4850 *10,750	*4850 *10,750	5.60 18.30
6.0 m 20.0 ft	kg lb							*5400 *11,800	5350 11,400			*4450 *9,800	4250 9,550	6.83 22.50
4.5 m 15.0 ft	kg lb					*6800 *14,650	*6800 *14,650	*5800 *12,650	5150 11,100	*4900 3600		*4350 *9,550	3550 7,850	7.57 25.00
3.0 m 10.0 ft	kg lb					*8500 *18,350	7450 16,050	*6550 *14,200	4900 10,550	5550 11,850	3500 7,550	*4450 *9,750	3200 7,050	7.96 26.70
1.5 m 5.0 ft	kg lb					*10 050 *21,650	6950 14,950	*7350 *15,850	4650 10,000	5400 11,600	3400 7,300	*4750 *10,400	3050 6,750	8.05 26.70
0 m 0 ft	kg lb					*10 700 *23,150	6700 14,350	7350 15,800	4500 9,650	5300 11,450	3300 7,150	5000 10,950	3100 6,850	7.86 25.80
-1.5 m -5.0 ft	kg lb			*11 600 *26,450	*11 600 *26,450	*10 550 *22,850	6650 14,250	7300 15,700	4450 9,550			5450 12,050	3400 7,500	7.35 24.10
-3.0 m -10.0 ft	kg lb			*13 200 *28,600	13 100 28,100	*9600 *20,700	6750 14,500	*7050 *15,100	4500 9,750			*6300 *13,900	4100 9,100	6.47 21.70
-4.5 m -15.0 ft	kg lb					*7100 *14,850	7050 *14,850					*6150 *13,450	6150 *13,450	4.98 16.70



ISO 10567



*Indicates that the load is limited by hydraulic lifting capacity rather than tipping load. The above loads are in compliance with hydraulic excavator lift capacity standard ISO 10567:2007. They do not exceed 87% of hydraulic lifting capacity or 75% of tipping load. Weight of all lifting accessories must be deducted from the above lifting capacities. Lifting capacities are based on the machine standing on a firm, uniform supporting surface. The use of a work tool attachment point to handle/lift objects, could affect the machine lift performance.

Lift capacity is for "Heavy Lift" mode, without bucket. Lift capacity stays with ±5% for all available track shoes.

Always refer to the appropriate Operation and Maintenance Manual for specific product information.

Standard Equipment

Standard equipment may vary. Consult your Cat dealer for details.

ENGINE

- C7.1 electronic control engine
- Meets China III Nonroad emission standards
- Air prefilter
- 5000 m altitude capability
- Radial seal air filters (primary and secondary filter)
- Glow plugs (for cold weather start)
- Automatic engine speed control with one touch low idle
- High ambient cooling package 52° C (125° F)
- Starting kit, cold weather, <-18° C (-0° F)
- Water separator with water level indicator sensor
- Waved fin radiator with space for cleaning
- Two speed travel
- Electric priming pump
- Power modes (Eco and High Power)

HYDRAULIC SYSTEM

- Regeneration circuits for boom and stick
- Auxiliary hydraulic valve
- Reverse swing damping valve
- Automatic swing parking brake
- Boom drift reducing valve
- Boom lowering device for back-up
- Stick drift reducing valve
- High performance hydraulic return filters
- Capability of installing additional valves, pumps, circuits
- Cat Bio-oil capability up to B20

CAB

- Pressurized cab
- Positive filtered ventilation
- Fully adjustable mechanical suspension seat
- Adjustable armrest
- Seat belt, retractable (51 mm [2 in])
- 70/30 split front windshield
- Laminated upper front windshield and tempered other windows
- Sliding upper door window
- Openable front windshield with assist device
- Openable roof hatch
- Removable lower windshield, within cab storage bracket
- Pillar mounted upper windshield wiper and washer
- Bi-level air conditioner (automatic) with defroster (pressurized function)
- Full color and full graphic LCD display with warning, filter/fluid change, and working hour information
- Control lever joysticks, seat integrated
- Neutral lever (lock out) for all controls
- Travel control pedals with removable hand levers

- Radio mounting (DIN size)
- 12V-10A power supply with two lighter sockets
- Two stereo speakers
- Beverage holder
- Coat hook
- Interior lighting
- Ashtray and lighter
- Storage compartment for lunch box
- Capability to install two additional pedals
- Sun visor/screen

UNDERCARRIAGE

- Idler and center section track guiding guards
- Towing eye on base frame
- Grease lubricated track GLT2, resin
- Heavy duty rollers
- Center track guiding guard

ELECTRICAL

- Batteries (2 × 900 CCA)
- 115 amp alternator
- 8 kW starter motor

LIGHTS

- Cab mounted working lights
- Right working light, storage box mounted
- Interior lighting

SAFETY AND SECURITY

- Cat one key security system
- Door and compartment locks
- Signaling/warning horn
- Rearview mirrors
- Rearview camera ready
- Fire wall between engine and pump compartment
- Emergency engine shutoff switch
- Rear window, emergency exit
- Battery disconnect switch
- Bolt-on FOGS capability
- Cap locks on fuel and hydraulic tanks
- Lockable tool box

COUNTERWEIGHT

- 4.26 mt (9,390 lb) counterweight

TECHNOLOGY

- Cat data link receptacle

323D2 L Optional Equipment

Optional Equipment

Optional equipment may vary. Consult your Cat dealer for details.

HYDRAULIC SYSTEM

- Boom and stick high pressure lines
- Hammer circuit, foot pedal operated

UNDERCARRIAGE AND GUARDS

- 600 mm (24") double grouser shoes
- 600 mm (24") triple grouser shoes
- 790 mm (31") triple grouser shoes
- Segmented track guiding guard (two pieces)
- Full length track guiding guard
- Guard package includes (HD) bottom, (HD) travel motor, swivel guard

FRONT LINKAGE

- Heavy Duty 5.7 m (18'8") reach boom with left side light
 - R2.9B1 (9'6") HD stick
 - R2.5B1 (8'2") HD stick
- Bucket linkage without lifting eye

LIGHTS

- Right mounted boom light for reach boom
- Lights, time delay

For more complete information on Cat products, dealer services, and industry solutions, visit us on the web at www.cat.com

© 2015 Caterpillar
All rights reserved

Materials and specifications are subject to change without notice. Featured machines in photos may include additional equipment. See your Cat dealer for available options.

CAT, CATERPILLAR, SAFETY.CAT.COM, their respective logos, "Caterpillar Yellow" and the "Power Edge" trade dress, as well as corporate and product identity used herein, are trademarks of Caterpillar and may not be used without permission.

VisionLink is a trademark of Trimble Navigation Limited, registered in the United States and in other countries.

AEHQ7625-01 (11-2015)
Replaces AEHQ7625
(GCN1)

