

Perkins Sabre M85T Marine Diesel Engine
 with the ZF25A (HSW250A) gearbox
 (Ratios 1.5:1 & 2:1)
 (Mounting Centres at 550mm)

CATERPILLAR MARINE POWER UK LTD
 Wimborne, Dorset, England.
 Tel. +44(0)1202 893720
 Fax. +44(0)1202 851700
 E-mail. Wimborne_MPC_post@cat.com
 www.Perkins-Sabre.com

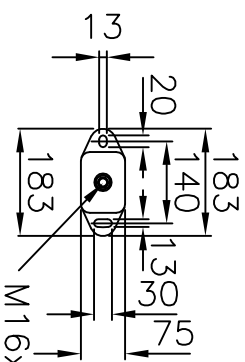

FLEXIBLE ENGINE MOUNT
 Weights on each mount
 Front – 73.4kg per mount
 Back – 92.7kg per mount
 Total Wet Weight 332.2kg

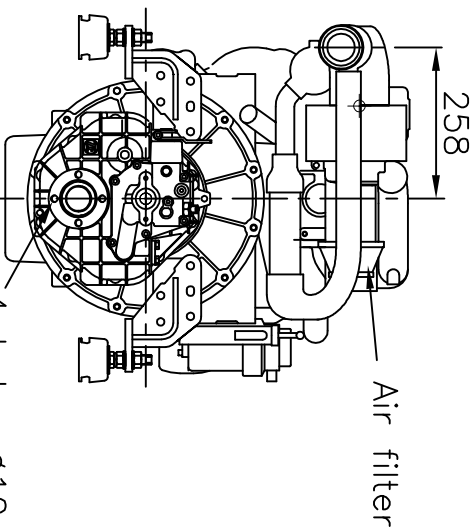
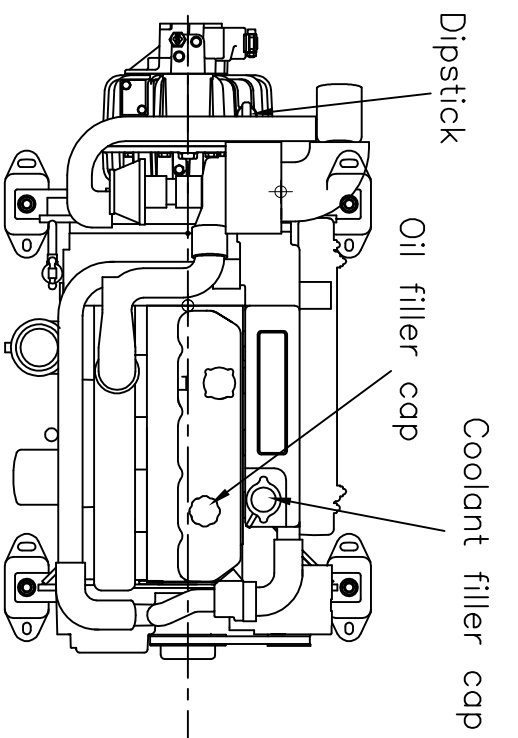