

1100 Series 4.4TGM Marine Auxiliary Engine

63.6 kW (85.3 hp) gross prime power @ 1800 rpm

Building upon Perkins proven reputation within the marine power generation industry. The 4.4 Series range of Marine Auxiliary engines now fit even closer to the needs of their customers'.

In the world of power generation success is greeted for those providing more for even less. Therefore with this new 4.4TGM unit, Perkins has engineered for its customers even higher levels of reliability, yet lowered the cost of owner ship. And with six cylinder capability from a four cylinder package performance increases, but crucially, bare engine noise is lower than ever before.

Rapid starting and pick-up are naturally built in especially for cold operation, but where legislation or local markets demand an emissions capability, then the 4.4TGM satisfies current European Emissions Legislation.

4.4 Series matches technology to customers needs. An in-line 4 cylinder, 4.4 litre unit very quietly sets a new standard in prime power supply and standby for the marine power generation industry.



Specification		
Number of cylinders	4 vertical in-line	
Bore and stroke	105 x 127 mm	4.1 x 5.0 in
Displacement	4.4 litres	268.5 in ³
Aspiration	Turbocharged	
Cycle	4 stroke	
Combustion system	Direct injection	
Compression ratio	19.3:1	
Rotation	Clockwise, viewed from front	
Total lubricating capacity	8.5 litres	2.2 US gal
Cooling system	Water cooled	
Total coolant capacity	15 litres	3.9 US gal

www.Perkins.com/Marine

Photographs are for illustrative purposes only and may not reflect final specification.
All information in this document is substantially correct at time of printing and may be altered subsequently.
Final weight and dimensions will depend on completed specification.

Part No. N41140B Issue 4. Produced in England ©2015

 **Perkins**®

THE HEART OF EVERY GREAT MACHINE

1100 Series 4.4TGM Marine Auxiliary Engine

63.6 kW (85.3 hp) gross prime power @ 1800 rpm

Features and benefits

Powered by your needs

- Perkins engines can be tailored specifically for you.

These engines offer a choice of standard build configurations to match the needs of customers for a diverse range of applications

Lower operating costs

- Service intervals 500 hours as standard and Perkins provides comprehensive warranty cover for two years, with three years on major engine components

Economic power

- One side servicing and cast aluminium header tank for reduced service time and cost. Extended service intervals, including 500 hour (or 12 months) oil change period, and competitively priced parts provide low cost of ownership. Keeping our customers engines running wherever they are in the world

Durable power

- Maximum cooling efficiency is provided by a gear driven water pump. Leak free operation is ensured by Viton crankshaft seals and sophisticated controlled swell joints, giving protection in the toughest conditions. Inserted valve seats, oil spray cooled pistons and compact plate cooler give enhanced engine life

Reliable power

- Suitable for operation in ambient temperatures up to 50°C and sea waters up to 38°C. Fuelled starting aid for temperatures down to -15°C. Approved by classification societies and marine authorities

Product support

- Perkins actively pursues product support excellence by ensuring our distribution network invest in their territory – strengthening relationships and providing more value to you, our customer
- Through an experienced global network of distributors and dealers, fully trained engine experts deliver total service support around the clock, 365 days a year. They have a comprehensive suite of web based tools at their fingertips covering technical information, parts identification and ordering systems, all dedicated to maximising the productivity of your engine
- Throughout the entire life of a Perkins engine, we provide access to genuine OE specification parts and service. We give 100% reassurance that you receive the very best in terms of quality for lowest possible cost .. wherever your Perkins powered machine is operating in the world
- To find your local distributor: www.perkins.com/distributor

E-mail: Marine@Perkins.com Web: www.Perkins.com/Marine

Photographs are for illustrative purposes only and may not reflect final specification.
All information in this document is substantially correct at time of printing and may be altered subsequently.
Final weight and dimensions will depend on completed specification.
Part No. N41140B issue 4
Produced in England ©2015

 **Perkins**[®]
Marine Power

1100 Series 4.4TGM Marine Auxiliary Engine

63.6 kW (85.3 hp) gross prime power @ 1800 rpm

Technical information

Benefits

- Excellent power to weight
- Ease of Installation
- Clean, quiet, smooth operation
- Excellent fuel economy
- Easy to maintain with 500hr Service interval
- Reliability

Standard features

- Backend – SAE3
- Water jacketed exhaust manifold
- Flat bottomed cast iron sump
- Wiring harness with 23 way connector
- Electronic governor (control to ISO 8528 G3)
- Rotary fuel injection pump
- Spin on fuel oil filter and separator
- Spin on full flow lube oil filter with integral lubrication oil cooler on left side of engine
- Thermostatically controlled cooling water system
- Gear driven fresh water pump
- Air filter
- Closed engine breather system
- Deaeration headertank
- User's handbook

Optional equipment

- Engine mounting brackets
- Exhaust outlets-either dry with bellows and silencer or water injected
- 12 or 24 volt insulated electrics
- Control panel options
- Heat exchanger or keel cooling with radiator cooled versions available
- Double skin high pressure fuel lines
- PTO facility
- Additional starter options
- 5000 hours parts kit
- Toolkit
- Belt cover
- Classification Society certification

E-mail: Marine@Perkins.com Web: www.Perkins.com/Marine

Photographs are for illustrative purposes only and may not reflect final specification.
All information in this document is substantially correct at time of printing and may be altered subsequently.
Final weight and dimensions will depend on completed specification.
Part No. N41140B issue 4
Produced in England ©2015

1100 Series 4.4TGM Marine Auxiliary Engine

63.6 kW (85.3 hp) gross prime power @ 1800 rpm

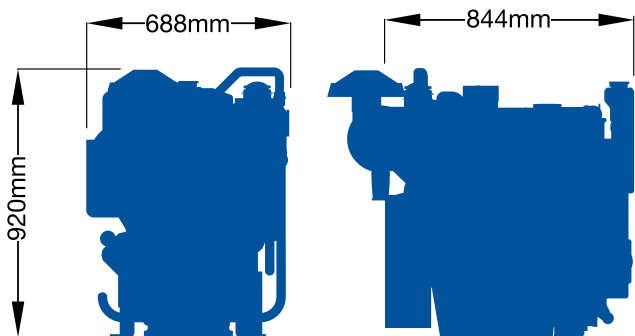

Engine package weights and dimensions		
Length	844 mm	33 in
Width	688 mm	27 in
Height	920 mm	36 in
Weight (dry)	478 kg	1054 lb

E-mail: Marine@Perkins.com Web: www.Perkins.com/Marine

Photographs are for illustrative purposes only and may not reflect final specification.
All information in this document is substantially correct at time of printing and may be altered subsequently.
Final weight and dimensions will depend on completed specification.
Part No. N41140B issue 4
Produced in England ©2015

1100 Series 4.4TGM Marine Auxiliary Engine

63.6 kW (85.3 hp) gross prime power @ 1800 rpm

Speed rpm	Type of operation	Typical generator output (Net)		Engine power			
				Gross		Net	
		kVA	kWe	kW	hp	kW	hp
1800	Prime power	71.6	57.2	63.6	85.3	63.6	85.3
	110%	78.8	63.0	70.0	93.9	70.0	93.9

Rating definitions

Prime power: Power for continuous service. Overload of 10% is permitted for 1 hour in very 12 hours' operation.

For further details on definitions please contact your local Perkins distributor.

Percent of prime power	Fuel consumption at 1800 rpm g/kWh	Fuel consumption at 1800 rpm l/hr
100% power	3.7	16.9
110% power	3.9	18.0

These ratings represent the performance capabilities to conditions specified in BS5514:1996, ISO 3046/1:1995 and DIN 6271.

Test Conditions Air temperature 25°C (80.6°F) barometric pressure 100 kPa (29.5 in Hg), relative humidity 30%, maximum exhaust back pressure 6 kPa, maximum inlet restriction 3 kPa.

For operation outside of these conditions please consult your Perkins contact. Performance tolerance quoted by Perkins is ± 5%.

Electrical ratings assume a power factor of 0.8 and a generator efficiency of 90%.

E-mail: Marine@Perkins.com Web: www.Perkins.com/Marine

Photographs are for illustrative purposes only and may not reflect final specification.
 All information in this document is substantially correct at time of printing and may be altered subsequently.
 Final weight and dimensions will depend on completed specification.
 Part No. N41140B issue 4
 Produced in England ©2015