

Installation Manual

M65

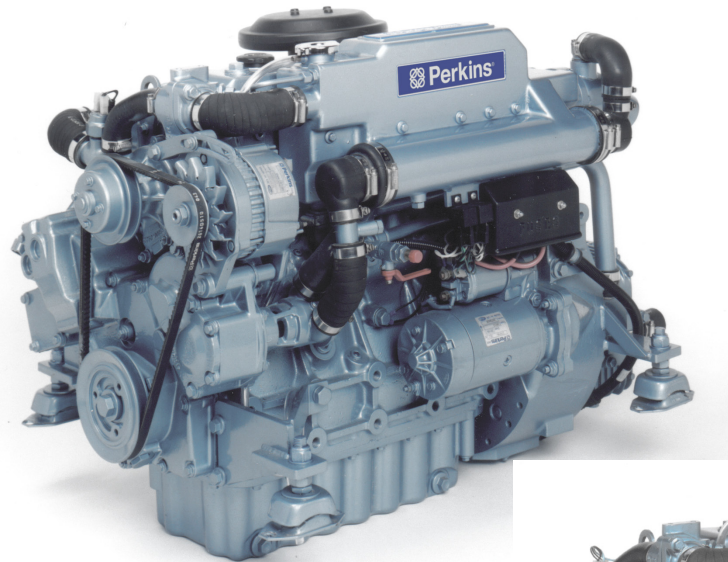

M85T

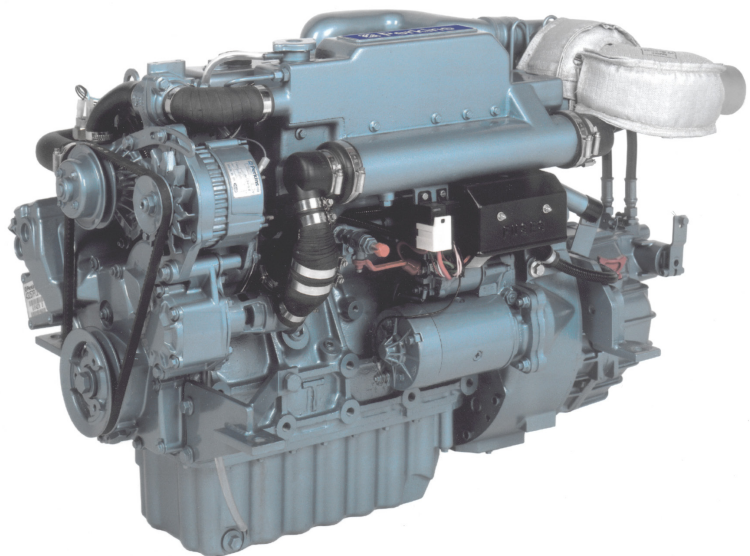

Perkins M65 and M85T Marine Diesel Engine

INSTALLATION MANUAL

**Four cylinder diesel engines for commercial and
pleasure boat applications**

Publication TPD 1399E, Issue 7.

Proprietary information of Wimborne Marine Power Centre, all rights reserved.

The information is correct at the time of print.

Published in December 2013 by Wimborne Marine Power Centre, Wimborne, Dorset, England. BH21 7PW

Tel: +44(0)1202 796000 **Fax:** +44(0)1202 796001 **E-mail:** Marine@Perkins.com

www.perkins.com/marine

Contents

Engine mounting	1
Installation angles	1
Installation angles (continued).....	2
Alignment of engine.....	3
Engine bearers	4
Design guidelines	4
Close spacing.....	4
Propeller shaft couplings	5
Part finished shafts	6
Flexible couplings	6
Exhaust systems	7
Wet Systems	7
Dry Systems	9
Water Lift Systems	10
Part wet / part dry systems.....	11
Systems for operation at high angles of heel.	12
Engine Room Ventilation	13
Engine Cooling Systems	15
Sea Water Systems.....	15
Keel cooling system.....	16
Fuel systems.....	17
Fuel connections	17
Fuel tanks.....	18
Multiple tanks.....	19
Engine electrical systems.....	21
Engine wiring loom	21
Insulated return.....	21
Fuseboard	23
Interconnecting cables and 'Y' harness.....	24
Instrument panels	25
Starter battery.....	29
Starter cables	29
Grounding the battery negative	29

Zinc Anode Bonding System	30
Typical System in Common Use	30
Engine controls	33
Provision for Power Take-Off	35
PTO Fitting Instructions	36
Electro Mechanical Bilge Pump.....	37
Calorifier Connections	37
Reference data.....	39

Engine mounting

Installation angles

The engine is intended to be installed so that the cylinders are vertical, when viewed from ahead or astern (A).

In service, however, the sump fitted as standard on the M65 and as an option on the M85T (B) may operate continuously at a heel angle of 20°, and intermittently (i.e. for up to 15 seconds at a time) at an angle of 25°.

A high inclination sump fitted as standard on the M85T, and as an option on the M65, allows an operating heel angle of 25° continuously, and intermittently up to 35°(C).

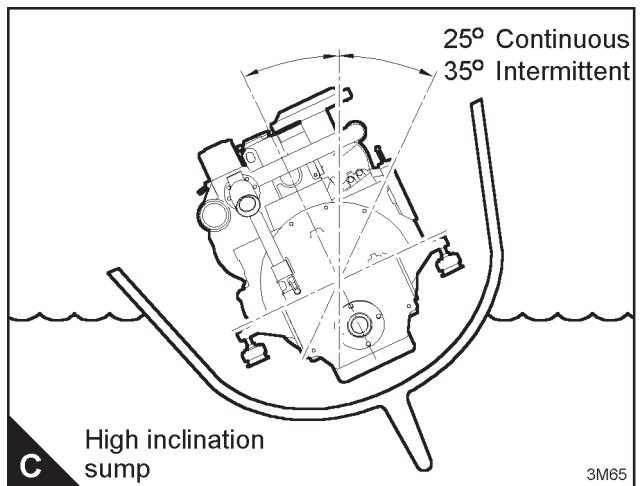
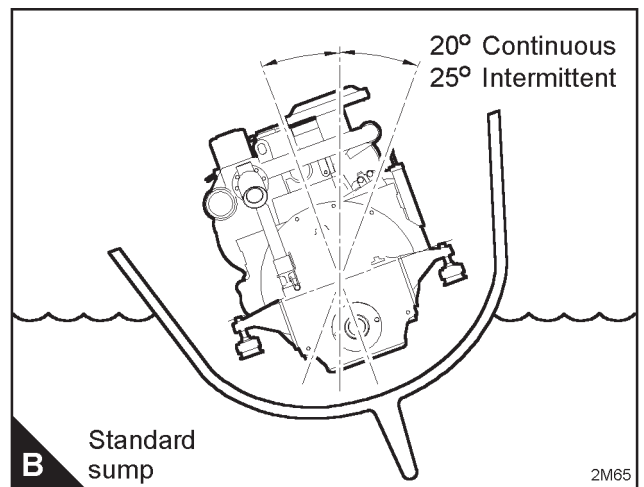
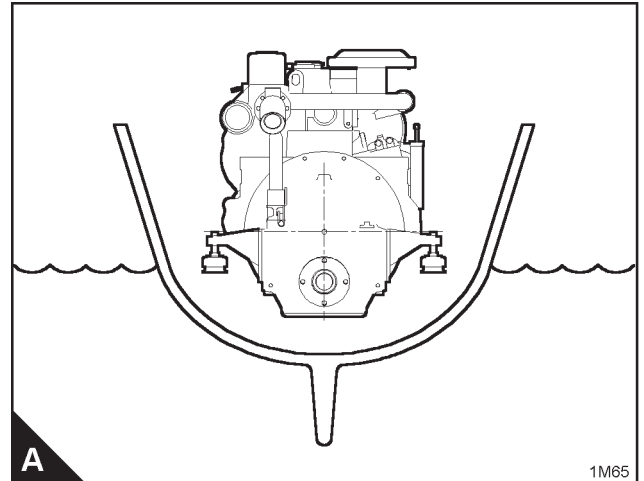

Installation angles (continued)

The engine is suitable for installation so that in side view the crankshaft is horizontal, or 'flywheel down' to a maximum of 17° (A).

An allowance has been made for an additional 3° rise to occur in service, when climbing waves or starting to plane.

Engine mounting brackets

The standard brackets provide mounting points which are 35mm below, and parallel with, the crankshaft centre line (B1).

The brackets may be used to mount the engine directly on to engine bearers, but for all applications it is recommended that flexible engine mounts are used (B2).

Engine mounting brackets are available for transverse mounting centres of either 460mm or 550mm (C1).

In both cases the longitudinal mounting centres are 654mm (C2).

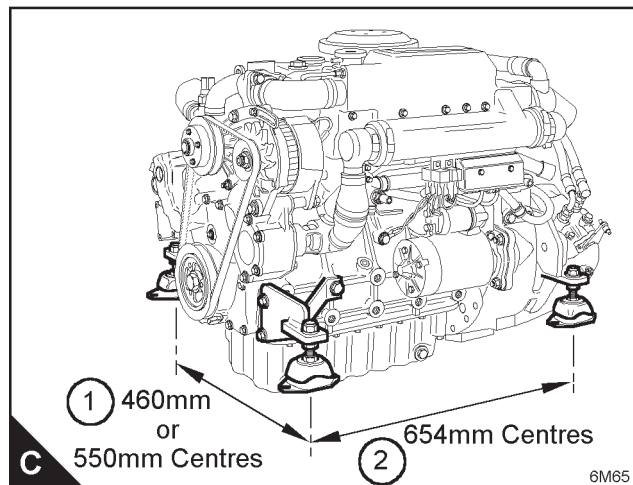
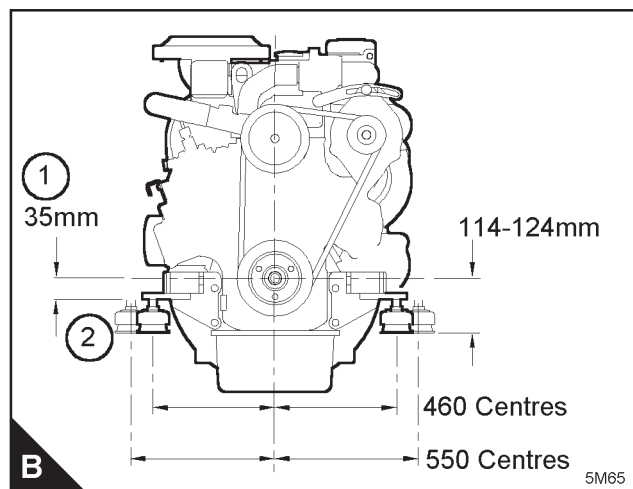
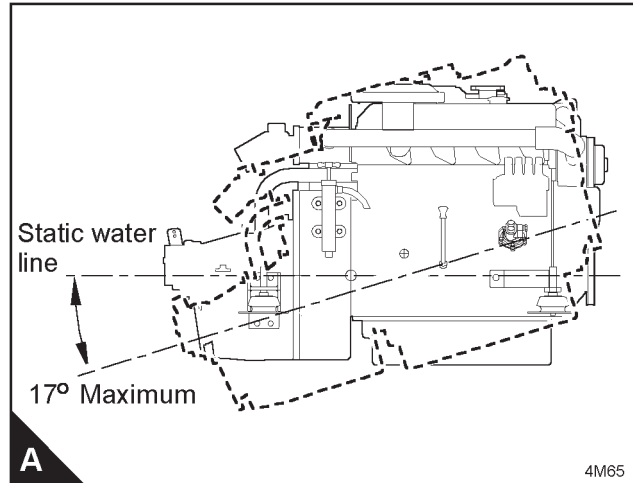

Alignment of engine

The following method may be used:-

Place the engine on the bearers in the hull (A) and adjust its position until it is aligned to the propeller shaft, both when viewed from above and from the side.

Drill 4 holes in the engine bearers in the positions shown (B1, B2, B3, B4). Bolt the mounts to the bearers, but do not fully tighten (if the mount has a cross slot and a longitudinal slot, bolt through the longitudinal slot).

Carry out any fine side-to-side adjustments necessary by allowing the mount to rotate slightly about the bolts just fitted (C).

Then drill the remaining 4 holes for the engine mounts through the centres of the slots. Fit bolts and tighten all around.

The mounts are provided with studs to provide easy height adjustment, but applications where there may be heavy impacts should use shims for height adjustment.

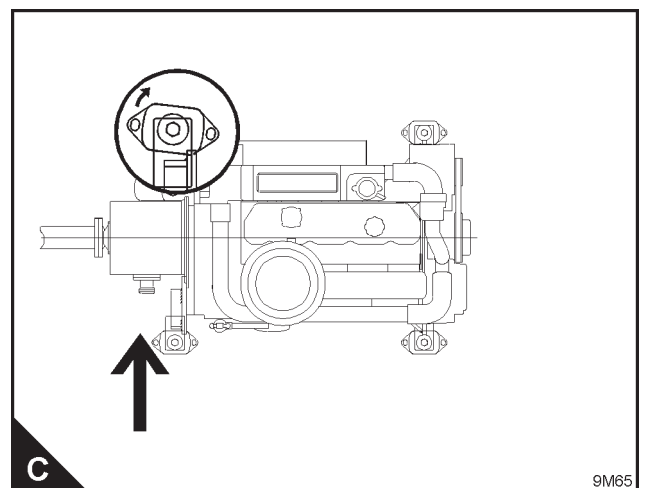
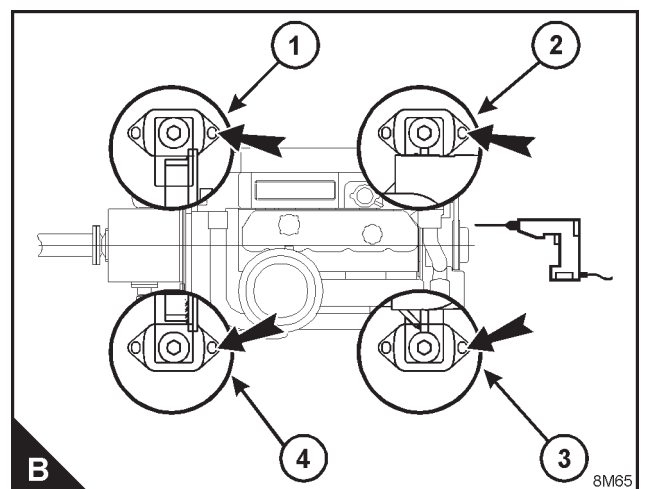
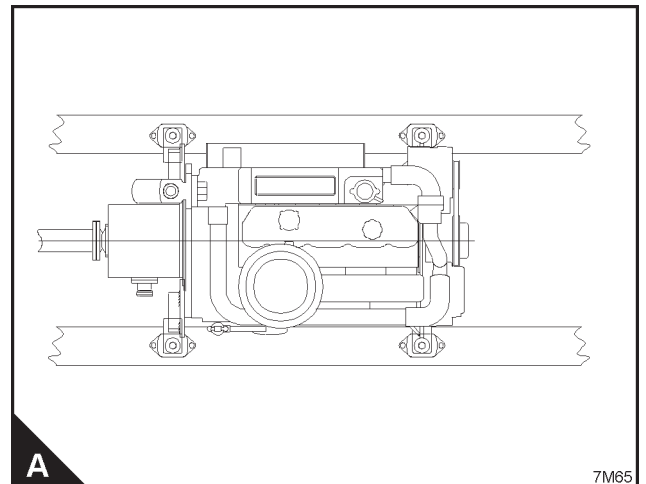

Engine bearers

Many types of engine bearer have been found to be satisfactory in service, including:-

Foam filled f.r.p. with metal plates bonded in, which are drilled and tapped during engine installation.

Plywood, with epoxy or f.r.p. coating.

Steel channels, attached to bulkheads fore and aft.

Although it is common for the engine mountings to sit on top of the bearers, in some cases the bearers are spaced so that the engine fits between the inner faces, supported by stirrup brackets (A).

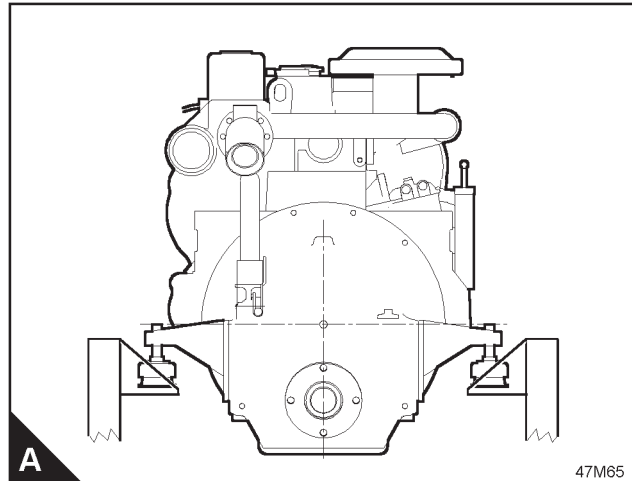

Design guidelines

The following rules apply to all bearers:-

The bearers should be capable of supporting a static load of 5 to 8 times the weight of the engine and gearbox, to cater for the effects of rough seas.

Cross connections should be arranged to give lateral rigidity, in order to maintain shaft alignment and to prevent twisting and racking forces being applied to the engine.

If the bearers are flexible, unwanted vibrations may be set up in the hull, so the assembly should be made as stiff as possible.

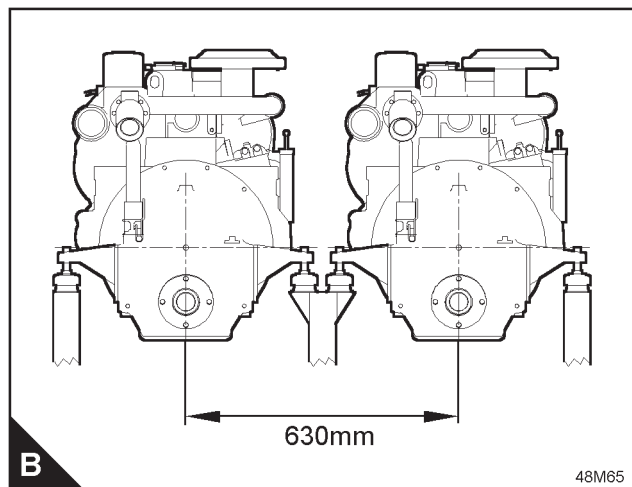

Close spacing

To enable minimum shaft centre distances to be achieved in a twin installation, a common centre bearer supporting the inner mountings of both engines is sometimes used as shown in (B). By this method shaft centres down to 630mm may be adopted.

The shaft centres could be reduced further, but this would result in the engine accessibility becoming very restricted, and it would be impossible to carry out service operations.

It should be noted that if minimum shaft centres are to be adopted, space must be left in front of and behind the engine to provide access. A minimum clearance on all sides will mean that the engine cannot be serviced!

Propeller shaft couplings

Flanged shaft couplings can be supplied with any gearbox. The couplings are pilot bored and must be machined to suit the propeller shaft, and provision must be made to take thrust, both ahead and astern.

The following machining procedure is recommended.

1. Machine the propeller shaft end to reduce the diameter by about 2mm, over a length to suit the coupling, as shown on (A1). Machine keyway slot in shaft (A2).
2. Bore the coupling to give a transitional fit on the shaft end and broach to suit the key.
3. Assemble the coupling and shaft with the key, ensuring that the shaft is pushed fully home (B1).
4. Drill a hole (1/4" diameter) so that it extends at full diameter for not more than 2mm into the shaft (measured on the shaft diameter) (B2).
5. Remove shaft, then open up the hole in the coupling to 5/16" or 8mm, and tap 3/8" UNC. Clean up the bore of the coupling as necessary.
6. Reassemble the shaft to the coupling. Fit the half dog 3/8" UNC grubscrew (C1) (supplied with the coupling). The grubscrew locks the coupling to the shaft and will accept astern thrust (C).

Alternative methods of providing for astern thrust (in place of the grubscrew) include:-

- Drilling right through the coupling hub and shaft (close to the flange) and fitting double roll pins (one inside the other).
- Using a washer secured by a bolt threaded into the shaft end. The coupling will require machining to accommodate these components, and the shaft engagement within the coupling will require adjustment.

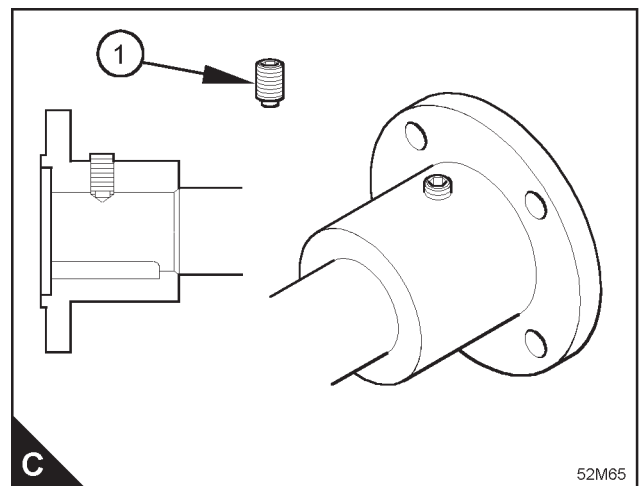
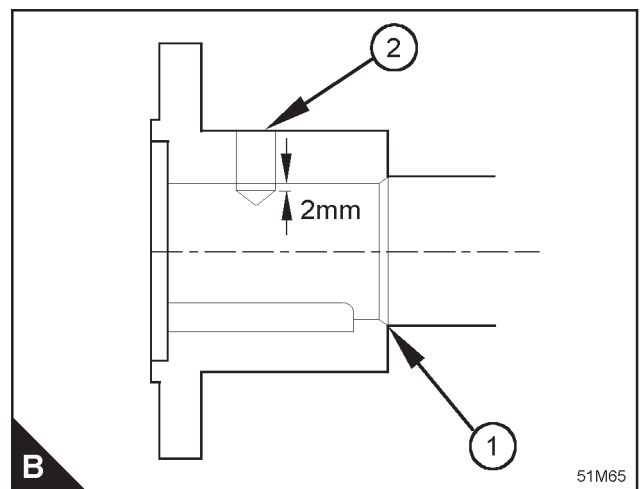
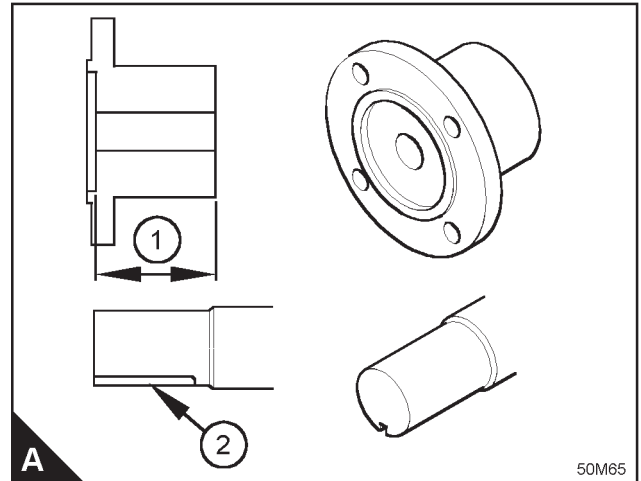

Part finished shafts

Where the precise shaft length can not be determined until the engine has been fitted in the boat, propeller shafts are sometimes supplied with excess length, to be completed locally.

In these cases a clamp type coupling (A) should be used, and it is not necessary to machine a shoulder on the shaft end to take forward thrust. It is good practice however to use one of the methods described above to provide a safeguard against loss of the shaft when going astern.

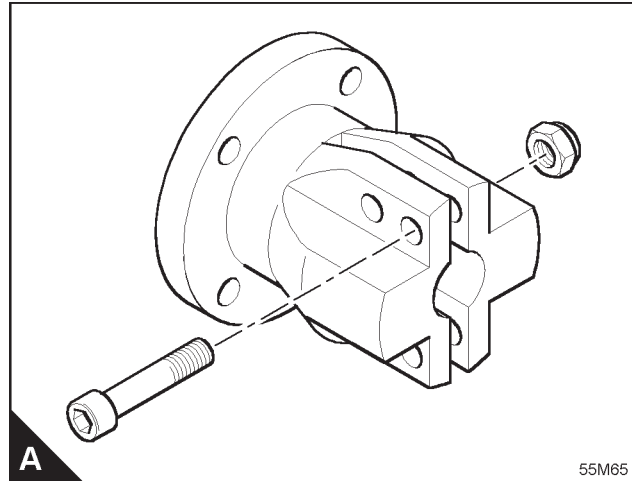

Flexible couplings

Elasticity may be incorporated in the connection between the gearbox output flange and the propeller shaft by means of a flexible coupling (B1). This type of coupling is not intended for use with continuous misalignment, but will cater for momentary deflections, due for example to the effect of shock loadings on the anti-vibration mounts supporting the engine. The flexible coupling is sandwiched between the gearbox output flange and the shaft coupling.

Couplings can be supplied to suit most of the marine transmissions that may be specified with the engine.

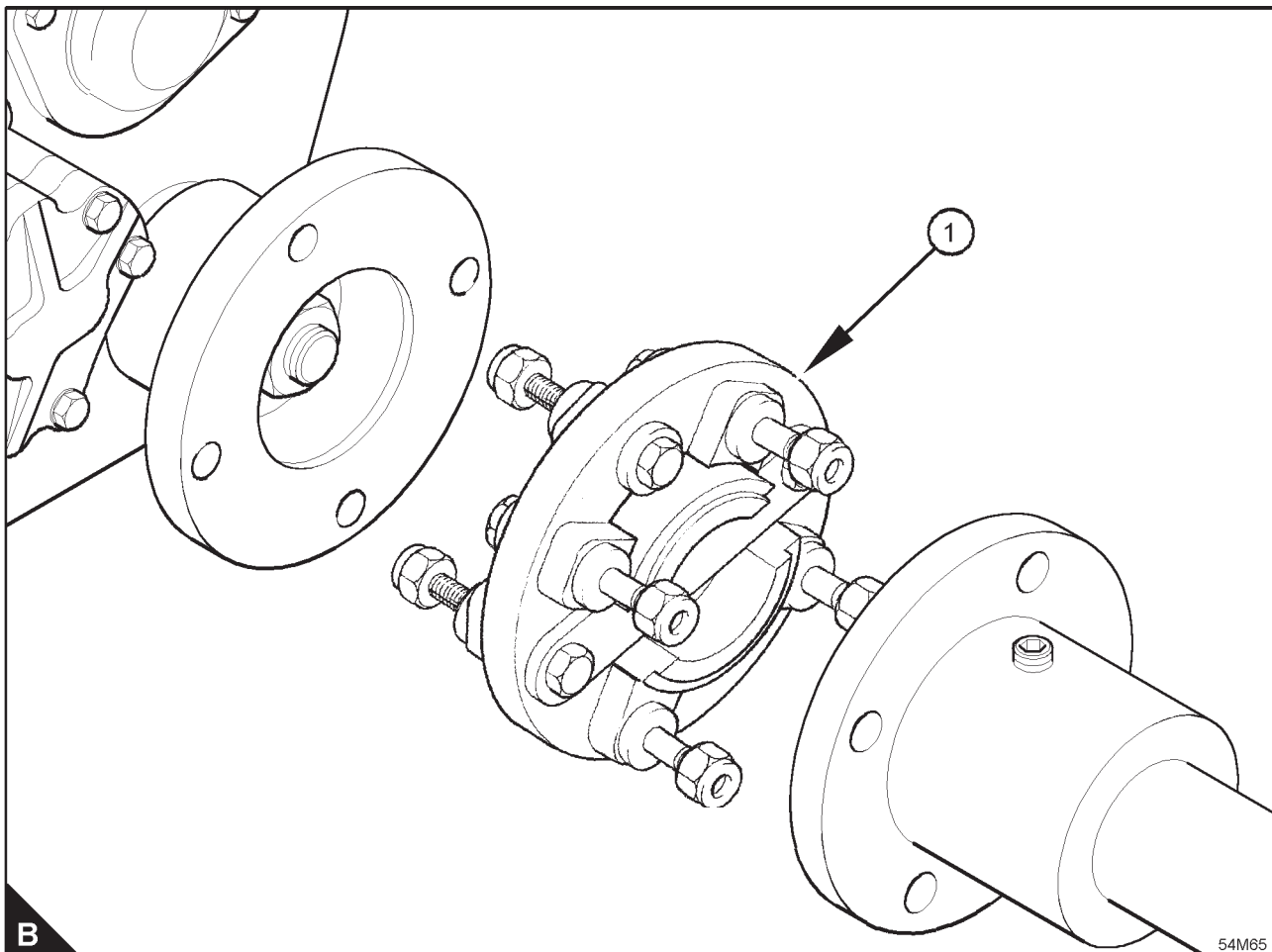

Exhaust systems

A wide range of exhaust components are available for use with all types of exhaust systems. Some of the components are designed to connect together, allowing complex systems to be built from stock items, to suit most installations.

Caution: In all types of exhaust system the exhaust back pressure must not exceed 75mm (3 inches) of mercury when measured within 300mm (12 inches) of the engine exhaust manifold outlet.

Wet Systems

Wet exhaust systems, where the raw water which circulates through the engine-mounted heat exchanger is finally injected by means of a special exhaust elbow (A) into the exhaust pipe, are the most common choice for small craft. Their principal advantage is that a rubber exhaust hose may be used, with a fairly low surface temperature, which presents no risk of fire.

The exhaust elbow incorporates a water feed connection (A1) which may be used to cool a shaft stuffing box, and a sampling point (A2) for temperature or pressure measurements.

Warning! Use a siphon break where a water lift exhaust system is specified, see page 10.

A general arrangement for such a system is shown in (B). It is usual for the exhaust outlet to pass through the transom just above the waterline. The minimum average fall (B1) should be 5°, and the point of water injection (B2) must be at least 200mm (8 inches) above the waterline, although the actual height necessary for a particular boat can only be decided in the light of the pitch and roll which may be encountered in service.

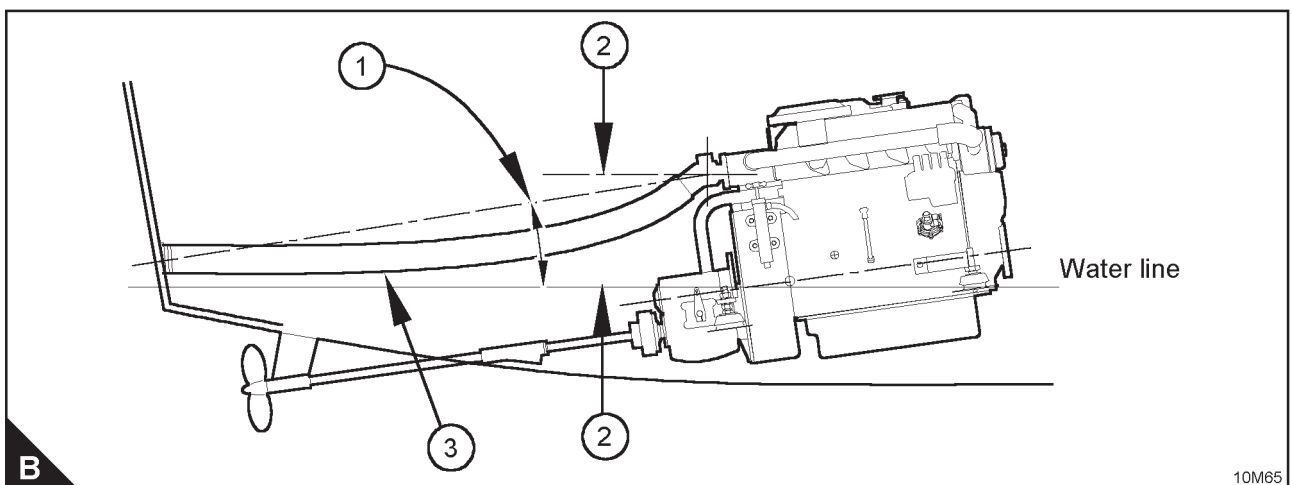
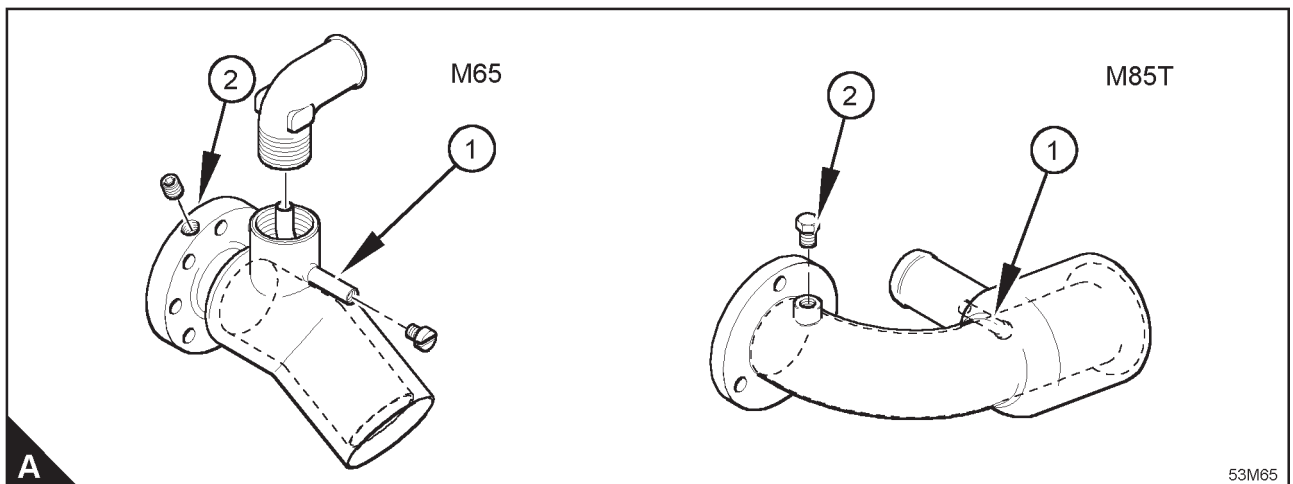

Caution: *It is essential that the exhaust system is designed so that water from the exhaust does not enter the engine under any conceivable operational condition.*

It is important that there is sufficient flexibility in the exhaust hose to allow the engine to move on its flexible mounts.

The internal diameter of the hose for the wet exhaust (B3) should be at least 63.5mm (2.1/2 inches)

Dry Systems

Dry exhaust systems are most commonly used with engines which are keel cooled. This arrangement is particularly useful for commercial or leisure craft operating in heavily polluted water.

Dry exhaust systems for marine installations need careful design to minimise the disadvantages of enclosing components that are at a high temperature in confined spaces. A typical system is shown in (A).

The first part of a dry system should include flexible connections (A1) to permit movement between the engine and the fixed part of the exhaust. Connections of the stainless steel bellows type are suitable, but care must be taken to ensure that they are only required to accommodate movements that do not involve twisting the ends of the bellows relative to each other.

The remainder of the exhaust system should be well insulated (A2) to avoid fire risk.

If there is a long exhaust run which gains height as it leaves the exhaust manifold, it may be necessary to incorporate a trap to collect condensate and allow it to be drained.

The minimum bore of the exhaust pipe should be 40mm (1.6 inches) for the M65 and 63.5mm (2.5 inches) for the M85T.

Note: Bellows should be in an unstrained condition when installed, so that the full bellows movement is available to absorb expansion and engine movement.

The weight of the exhaust system should be supported by brackets and not carried by the bellows.

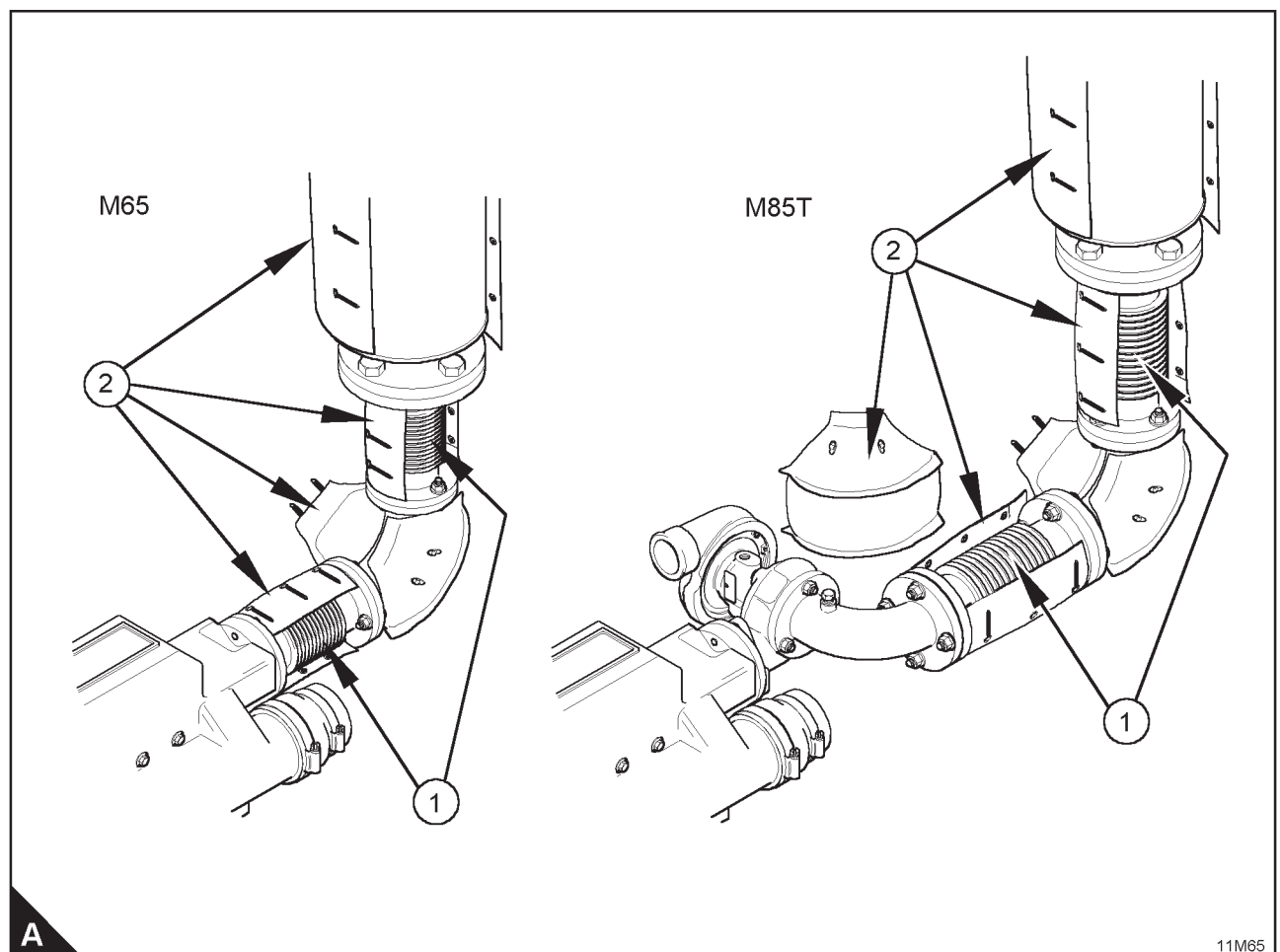

A

11M65

Water Lift Systems

In sailing yachts and deep draught displacement boats it may be found that the engine exhaust outlet is near or below the waterline, and a water lift exhaust system is then an option that may be considered.

The main features of such a system are shown in (A). Pressure developed by the exhaust gases force a mixture of gas and water to a height which may be considerably above the engine. When the engine is stopped the exhaust tank (A1) contains the water which falls back from the exhaust riser (A2).

If a proprietary unit is used the manufacturers instructions should be carefully followed, but the key features are shown in (A).

The exhaust tank (A1) should have a minimum volume equal to 3 times the volume of the water that could be contained in the exhaust riser (A2). On sailing craft the tank should be installed near the centre-line.

Particular care should be taken to prevent water from siphoning into the system and then flooding the engine. There are two routes by which this could happen; from the exhaust outlet or by the sea water feed to the engine.

The top of the exhaust riser (A3) should be 450mm (18 inches) above the static water-line, and the exhaust outlet (A4) should either be well above the static water level, or a siphon break should be fitted at (A5).

The exhaust system may also become flooded by water entering through the sea water system on the engine, as the sea water pump impeller may be damaged, and can not be relied upon to seal when stationary. To prevent such flooding the sea water pipework should reach a high point (A5) of 450mm (18 inches) above static water level prior to the point of water injection, and a siphon break should be fitted at that point

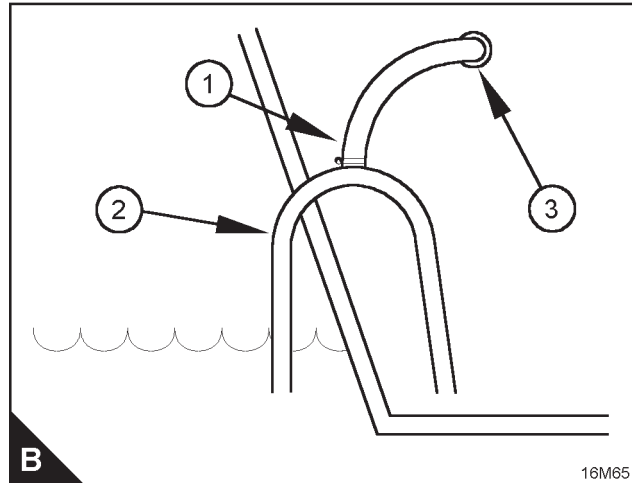

A siphon break (B1) admits air to the top of any 'inverted U bend' (B2) and prevents unwanted syphonic action.

The siphon break should vent through a skin fitting (B3) well above the water level.

Some proprietary siphon break units contain a valve to prevent water loss through the vent pipe.

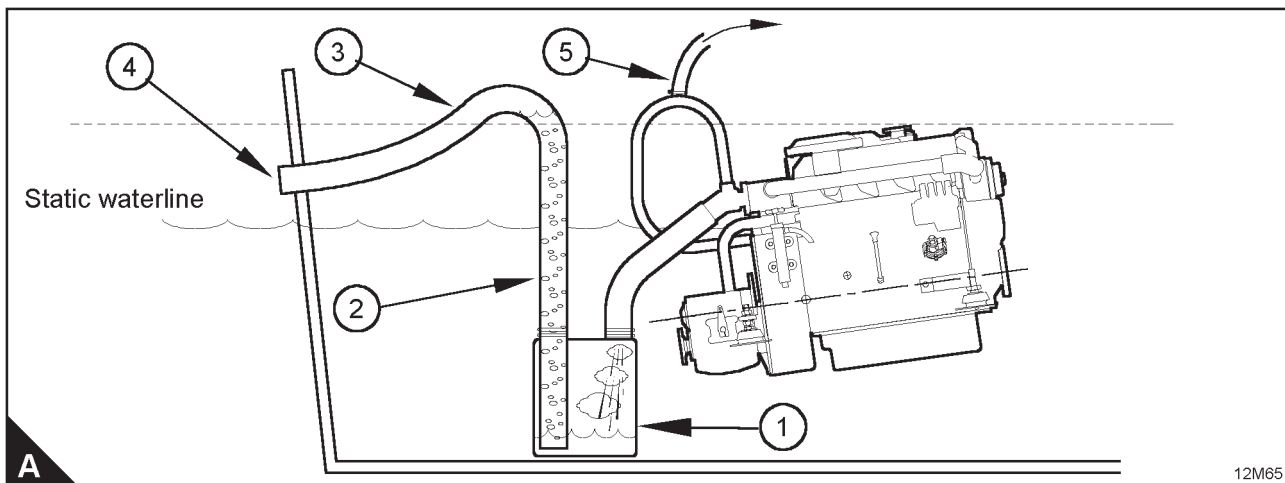

Part wet / part dry systems

In some installations this arrangement may be chosen in place of a water lift. The part wet / part dry system allows the engine exhaust manifold outlet to be near or below the waterline, and provides protection against sea water back-flooding into the engine exhaust.

The general arrangement (A) shows that the dry part of the system extends to a safe height above the water line, using an elbow (A1), a stainless steel bellows (A2), a riser pipe to give the required height (A3), and a further elbow (A4), which is supported from the deck head by a flexible hanger, which supports the weight of the system but permits movement side to side and fore and aft.

At this point water is injected into the exhaust through the injection elbow (A6), and the remainder of the system follows usual wet exhaust practice, with a rubber hose falling to a transom fitting.

The point of water injection should be at least 200mm (8") above the water-line, and the wet exhaust should have an average fall of at least 5°. The minimum diameter of the dry part of the system should be 40mm (1.6") for the M65 and 63.5 (2.5") for the M85T, and the wet part of the system should be not less than 63.5mm

(2. 1/2") for the M65 and 76mm (3") for the M85T. The dry part of the system should be insulated to avoid excessive heat loss to the engine compartment.

Note: The bellows should be in an unstrained condition when installed, so that the full bellows movement is available to absorb expansion and engine movement. The weight of the exhaust system should be supported by brackets, and not carried by the bellows.

A form of the part wet / part dry system shown on the next page may be used in racing yachts, which operate with high angles of heel.

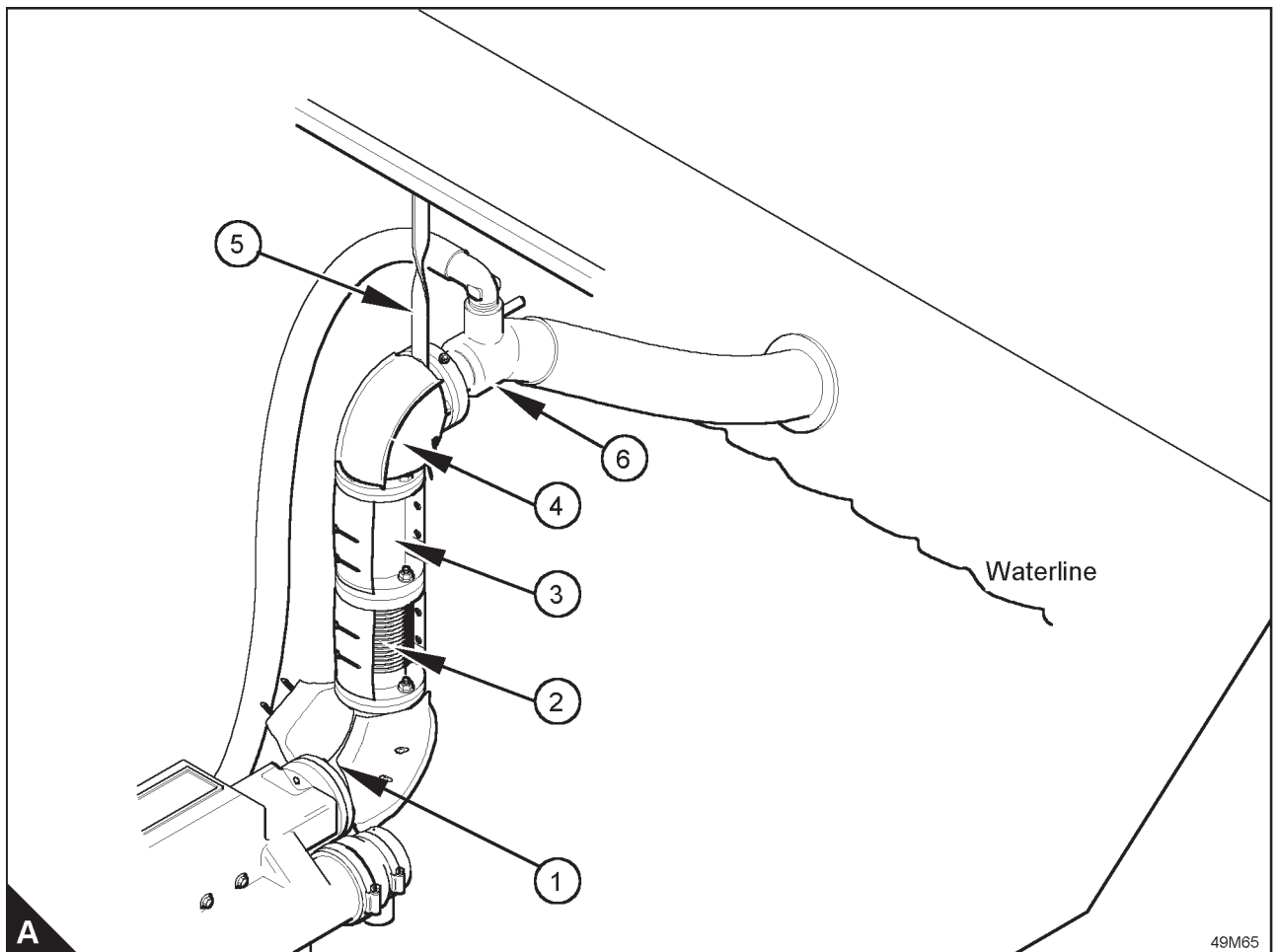

Systems for operation at high angles of heel.

Racing yachts may require special exhaust systems, if the engine is to be run when sailing (for example, to charge the batteries or to drive a watermaker pump).

A suitable system is shown on (A), in which a dry riser (A1) takes the gases up to a safe height above the waterline, on the hull centre-line. A water injection elbow (A2) then cools the exhaust gas, and the mixture of gas and water exits the hull either by a hose through the transom or by a cross pipe (A3) running between skin fittings on both sides of the hull, so that the exhaust gases can escape from whichever outlet is uncovered, and the raw water can escape through the submerged outlet.

The minimum diameter of the dry part of the system should be 40mm (1.6 inches) for the M65 and 76mm (3 inches) for the M85T and the wet part of the system should be not less than 63.5mm (2.1/2inches) for the M65 and 76mm (3 inches) for the M85T.

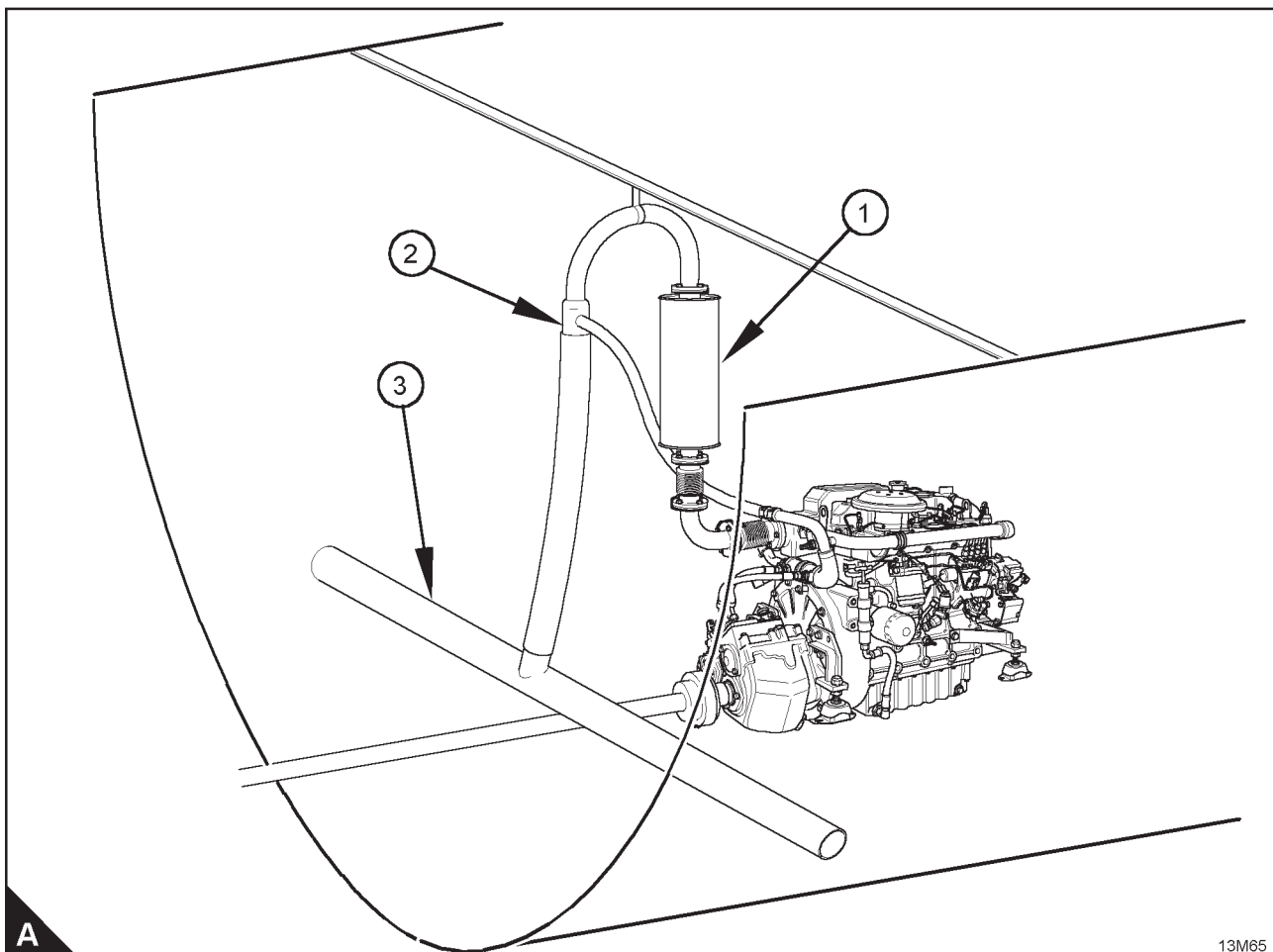

Engine Room Ventilation

The engine room must be ventilated for two reasons:

- To supply the engine with air for combustion.
- To provide a flow of air through the engine room to prevent an excessive temperature build up, which may cause components such as the alternator to overheat.

In most applications in temperate climates, the engine will draw air from the engine room. If this is the case then, as a rough guide, it can be taken that every horsepower produced by the engine requires, as a minimum, 1.6 sq. cm. (0.25 sq. ins) of vent area. If the boat is likely to be used in hot climates, and if engine room ventilation fans are fitted, then a vent area of 3.2 sq. cm. (0.5 sq. ins) per horsepower should be provided (see the table below). Wherever possible a flow of air through the engine room should be encouraged by using forward facing intake vents to take advantage of ram airflow.

With an effective ventilation system the engine air intake temperature will be no more than 10 Celsius degrees higher than the outside air temperature.

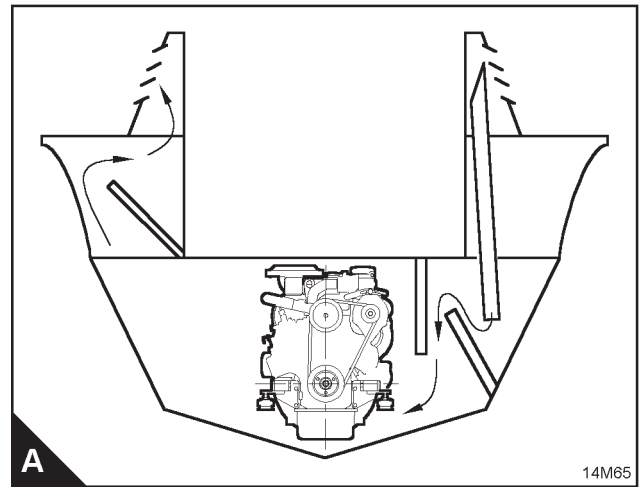

1. Minimum cross section of air duct per engine		
Model	For hot climates	For temperate climates
M65	210 sq.cm. (32 sq.ins.)	110 sq.cm. (16 sq.ins.)
M85T	260 sq.cm. (40.3 sq.ins.)	130 sq.cm. (20.1 sq.ins.)

The air entry vents should be situated where spray is not likely to enter them and some form of water trap is desirable (A).

When the engines are shut down after a run at high output in high ambient temperature conditions, it will be found that very high air temperatures will build up in the engine compartment. In boats with open cockpits this is usually of no real consequence but if the engines are mounted below a wheel house, then unpleasantly warm conditions may result. In these circumstances engine room ventilation fans are beneficial, preferably arranged to exhaust air from over the engine.

Engine Cooling Systems

Sea Water Systems

A completely separate sea water system should be provided for each engine to prevent a blockage resulting in the need to shut down more than one engine. A typical system is shown on (A).

The water intake fitting (A1) should not project appreciably below the bottom of the hull and it should be situated well clear of other components such as shafts, logs, rudders to prevent flow problems at high speeds. If desired the rear edge of the water intake may be allowed to project more than the front, by no more than 6mm, to give a slight scoop effect, but if this is done it is necessary to locate the fitting so that it cannot be inadvertently partially rotated.

The intake fittings and pipework should have a minimum bore of 25mm. Inboard of the intake fitting a sea cock must be provided (A2). This should be of the full flow type giving unobstructed passage to the water in the open position, with a minimum bore of 25mm.

Between the intake fitting and the sea water pump on the engine, there should be a strainer (A3) which should be easily accessible for routine examination, and the lid should be easily removable. Where possible mount the strainer so that the top is just above the waterline - this will allow the strainer to be cleaned without closing the sea cock.

From the sea water strainer a pipe should be run to the sea water pump inlet connection on the engine (B1). The pipe may either be mainly rigid, or for example copper or cupro-nickel, or flexible, but only flexible hose which is reinforced to prevent collapse should be used. Rubber hose connections in the sea water system should be kept as short as possible and should

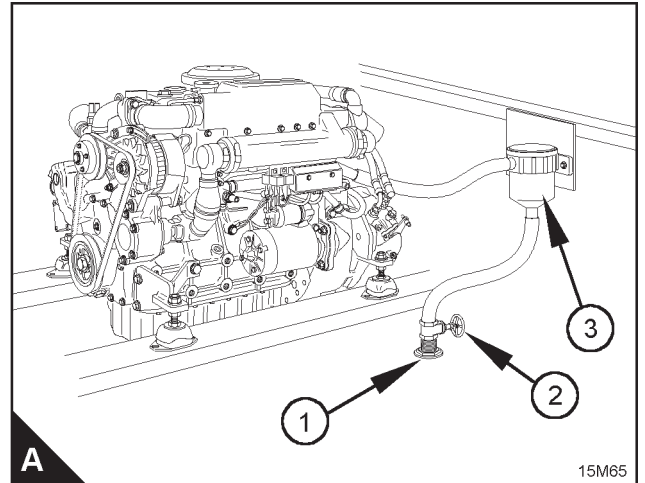

be reinforced with a minimum of three layers of canvas. The system must be sufficiently flexible to permit the engine to move on its anti-vibration mountings. The sea water pump connection is for hose with a 32mm bore.

A small supply of seawater is often needed to cool and lubricate the shaft log. A connection point (B2) is provided to suit 10mm bore hose.

Care should be taken to use compatible materials in the sea water systems, to prevent excessive electrolytic corrosion. Systems incorporating copper, cupro-nickel, stainless steel Type 316, gun-metal, silver solder, and aluminium brass will generally be satisfactory. Components made from lead, iron, steel, aluminium or its alloys, zinc or magnesium, should be generally avoided.

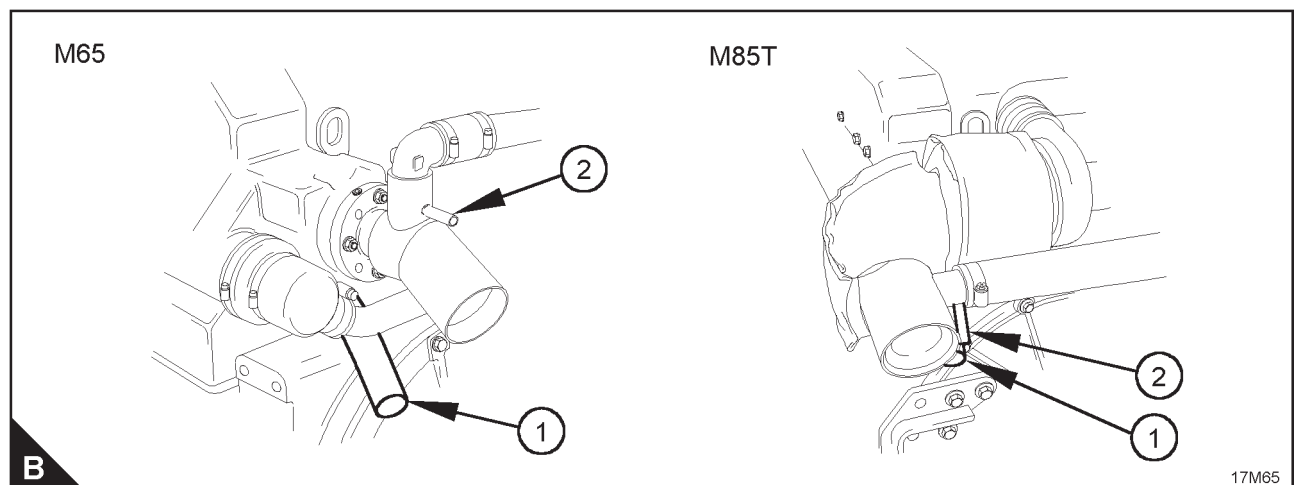

Keel cooling system

The M65 and M85T may be purchased in a form suitable for keel cooling. The engine connections provided for the cooler are to suit 32mm outside diameter rigid pipe, as shown in (A) and (B). The connection for the flow to the keel cooler is shown at (B1) and the return at (A1). The design data for the keel cooler is shown in the table below.

	M65	M85T
Heat rejection at rated power	40 kW (2300 Btu/min)	51kW (2908 Btu/min)
Design value for the temperature of the water returning from the keel cooler.	60°C	60°C
Design value for the water flow through the keel cooler.	90 litres/min (20 imp galls/min)	90 litres/min (20 imp galls/min)

The pipework between the engine and the cooler should be as short and direct as is possible, but should be sufficiently flexible to allow the engine to move on its anti-vibration mounts.

The pipe layout should discourage the formation of air locks, and venting points should be provided wherever an air lock is likely to occur.

The keel cooling system should normally be filled with a water/anti freeze mixture containing 50% antifreeze, to ensure that the inhibitors included in the antifreeze are present at a sufficient level to minimise corrosion.

Note: The illustrations show the connections on the M65, but are the same on the M85T.

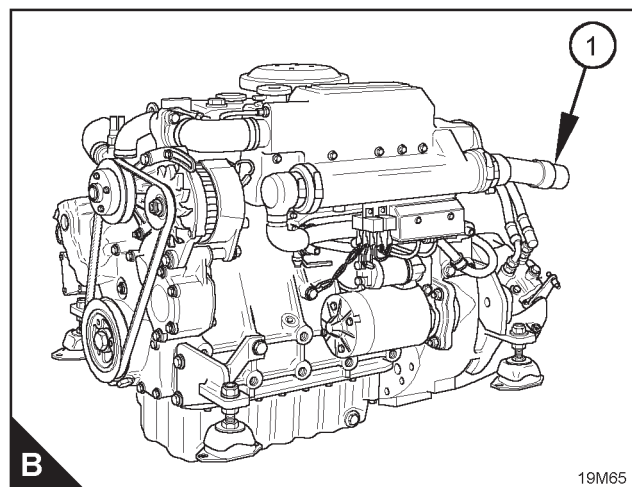
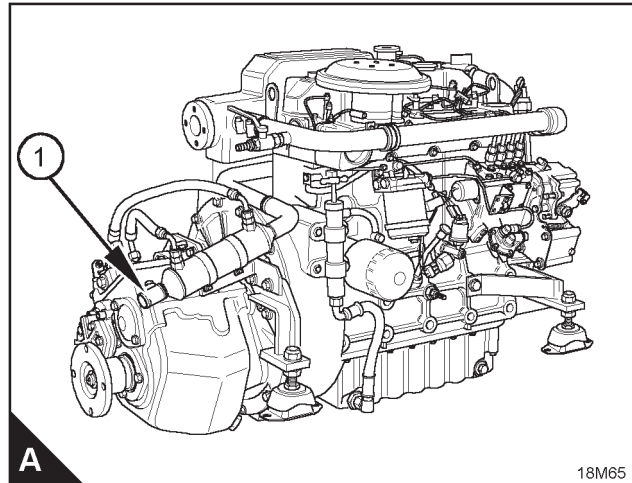

Fuel systems

In some applications there will be legislation covering the design of fuel systems. The details in this section are generally regarded as good practice, however, and may be used in the absence of a specific legislative directive.

Note: Many of the marine engine problems encountered at sea are due to design and assembly faults in the fuel system. A good system is not hard to achieve, and avoiding the pitfalls described in this section will go far towards achieving reliability in service.

Fuel connections

The M65 engine has connections for a fuel feed from the tank at the fuel lift pump (A2) and a fuel return to the tank from the fuel filter head (A1).

Fuel connections on the engine	
Fuel feed	1/2" UNS female for 5/16" OD pipe
Fuel return	7/16" UNS male for 1/4" OD pipe

It is recommended that the flexible fuel pipes available as an option with the engine are specified. These provide connections as shown below.

Optional flexible fuel pipes	
Fuel feed	The free end has a 1/4" BSP nut and olive to suit 5/16" OD pipe (to be supplied by installer)
Fuel return	The free end has a 1/4" BSP nut and olive to suit 1/4" OD pipe (to be supplied by installer)

Note: A common reason for service problems with fuel systems is the use of poor or incompatible connectors.

Flexible hoses should be used with purpose made end fittings, and should not be secured to a plain pipe with hose clamps.

Where adaptors are necessary to connect components with different thread sizes, sealing should be achieved, where possible, by the use of a thread sealant on tapered threads.

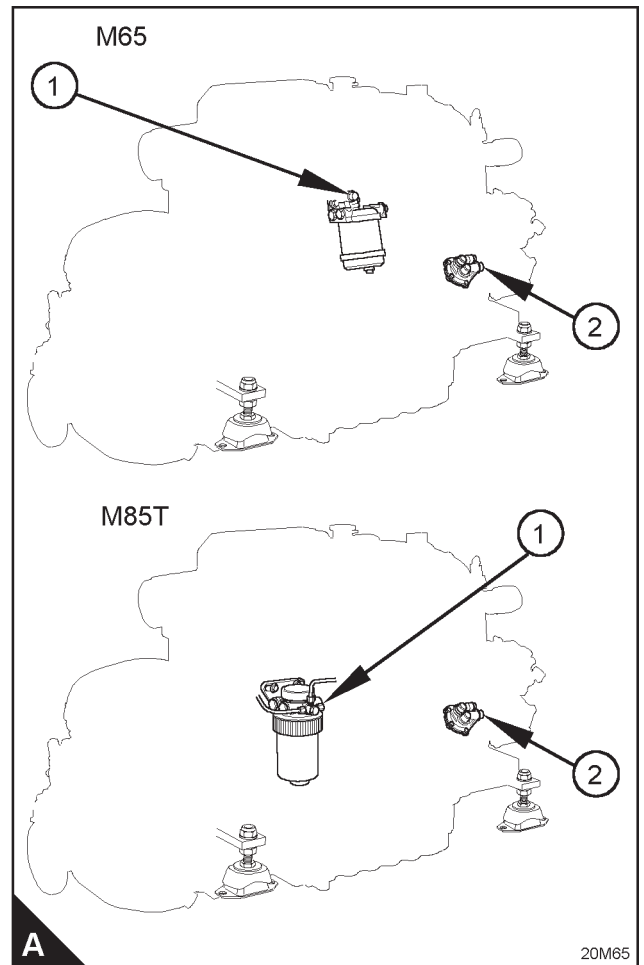

Fuel tanks

Fuel tanks should have the following features:

- The filler neck (A2) should be raised so that water will not enter when filling.
- The filler cap should seal effectively to prevent water entering when under way.
- A vent pipe (A3) should be fitted, again in such a way as to avoid the entry of water.
- The tank (A1) should have a sump or angled bottom with a drain tap (A4) so that water and sediment can be removed. (This is not always possible).
- Internal baffles (A5) may be required to prevent fuel surge.
- The tank should have a removable panel (A6) to simplify cleaning.
- The fuel pipework should be as simple as possible with the minimum of valves and cross connections, so that obscure fuel feed problems are minimised. In a multiple engine installation care should be taken to ensure that the pipework for each engine is kept separate.
- A fuel sedimenter (i.e. water trap) (A8) is required in the fuel system between the fuel tank and the engine mounted lift pump (A9). To avoid problems when venting air after draining the sedimenter, it should be preferably installed below the normal minimum level of fuel in the fuel tank. (This is not always possible!). A valve (A7) should be fitted between the tank and the sedimenter, so that when servicing the sedimenter the entire system will not drain down.
- The tank should have at least two connections; a fuel feed connection (A11), and a fuel return connection (A10), which should preferably be extended to near the bottom of the tank. Whenever

possible a tank should only supply one engine, but in any case each engine should have its own fuel pipes, from tank to engine.

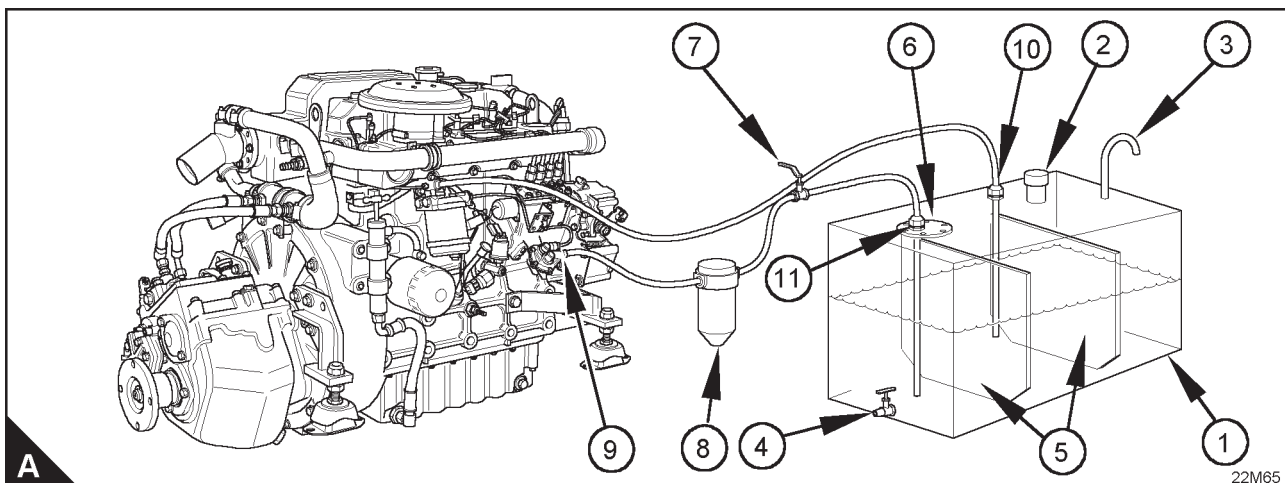

Multiple tanks

Where multiple fuel tanks are necessary the following methods are suitable.

- A main tank, with flow and return connections for the engine or engines, into which other tanks can be drained by gravity.
- Where more than one engine is fitted, a separate tank for each engine, with an (optional) balancing pipe between the tanks with a valve at each end.
- A collector tank, as shown on (A1), with flow and return connections for the engine(s) and a vent pipe (A11). The storage tanks (A2, A3, A4) can be connected to the collector tank by valves (A5, A6, A7), the flow passing through a sedimenter (A8).

Note: The fuel feeds to the engine (A9) should be taken from the bottom of the collector tank, and the return flow from the engine (A10) led to the top of the tank. The vent pipe (A11) should lead to the top of the highest storage tank.

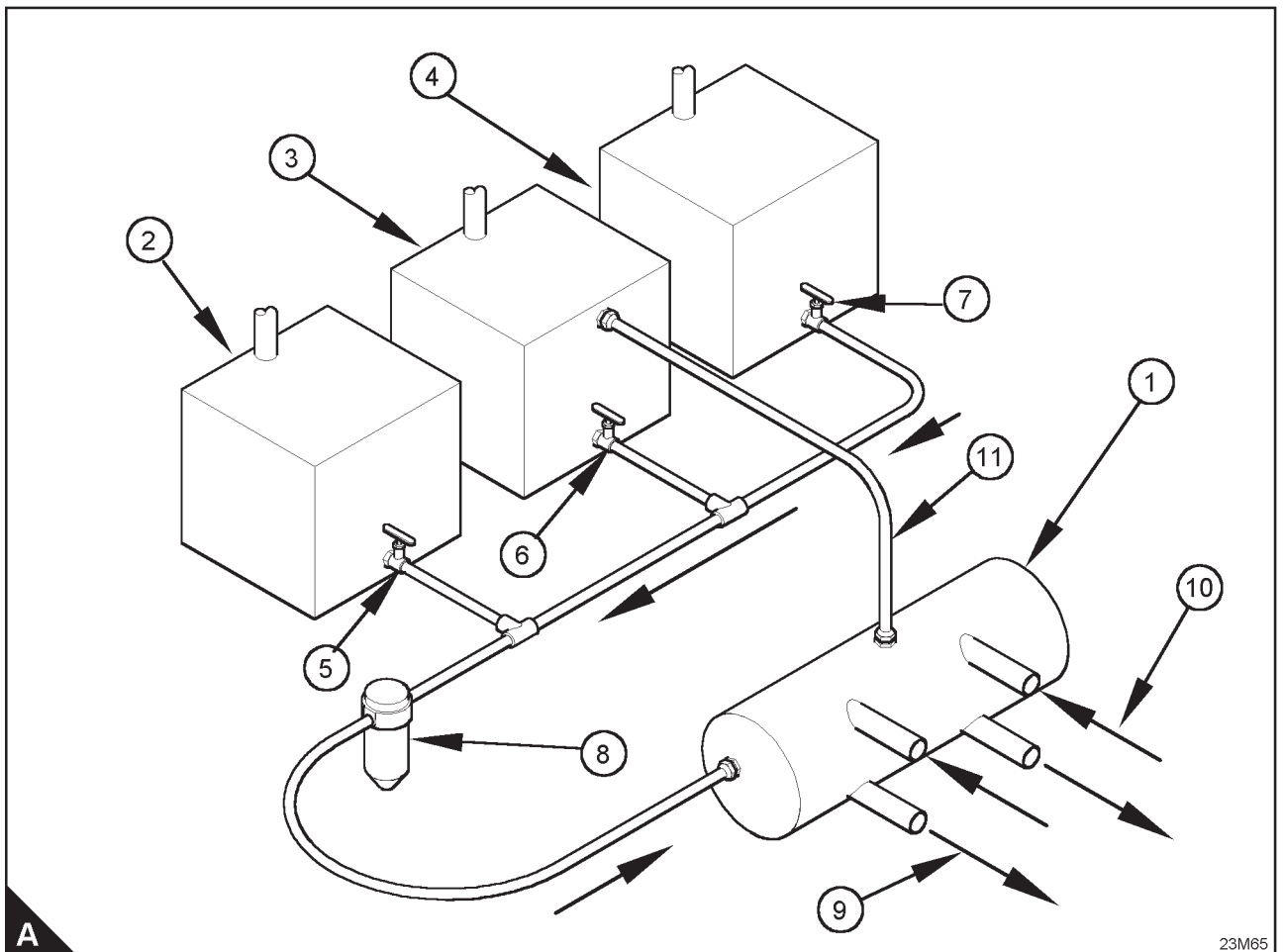

A

23M65

Engine electrical systems

A plug-together electrical system is available with the engine, providing the following choices:-

- Earth return or insulated return
- Interconnecting cables of 4, 6, 8, 10 or 12m length
- A 'Y' harness to allow multiple instrument panels to be fitted.
- Instrument panels - basic or comprehensive, which may be used individually or in combination.

Note: The nominal operating voltage for the M65 and M85T is 12v.

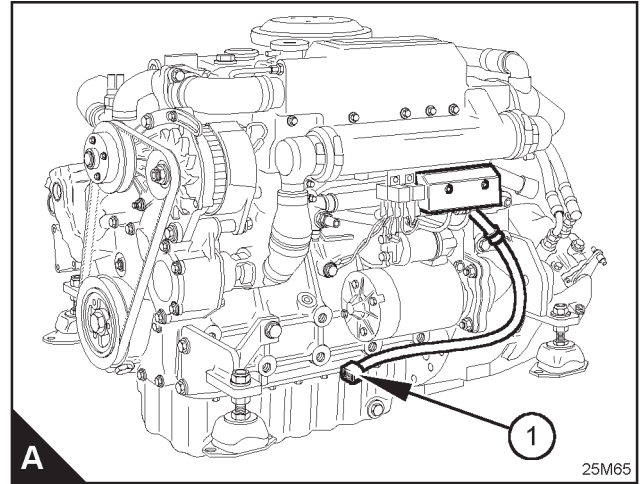

Engine wiring loom

The engine wiring loom connects the starter, alternator, fuse board, electric stop, engine senders and warning switches to a waterproof (IP67) multiway connector situated on a flying lead attached to the engine in position (A1). The circuit diagram is shown on page 22 where it will be seen that the system is earth return.

Insulated return

To convert to an insulated return, a kit incorporating a power relay can be specified. The relay momentarily connects the battery negative to the starter body and engine block during starter operation. The position of the relay is shown on (B), where (B1) is the cable from the battery negative, which is attached to terminal (B2) during engine installation. The circuit diagram for the engine wiring loom with insulated return is shown on page 22. (The cold start kit described is also included).

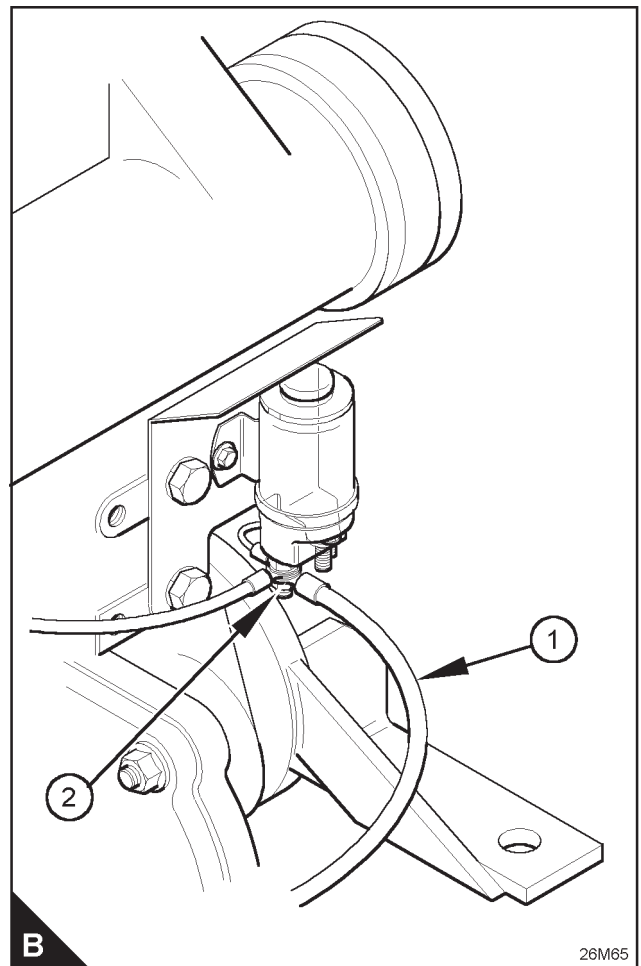



TERMINAL IDENTIFICATION FOR COMBINED PRESSURE SENDER AND SWITCH. WK = SWITCH, TO ALARM LAMP. G = SENDER, TO OIL PRESSURE GAUGE. M = -VE

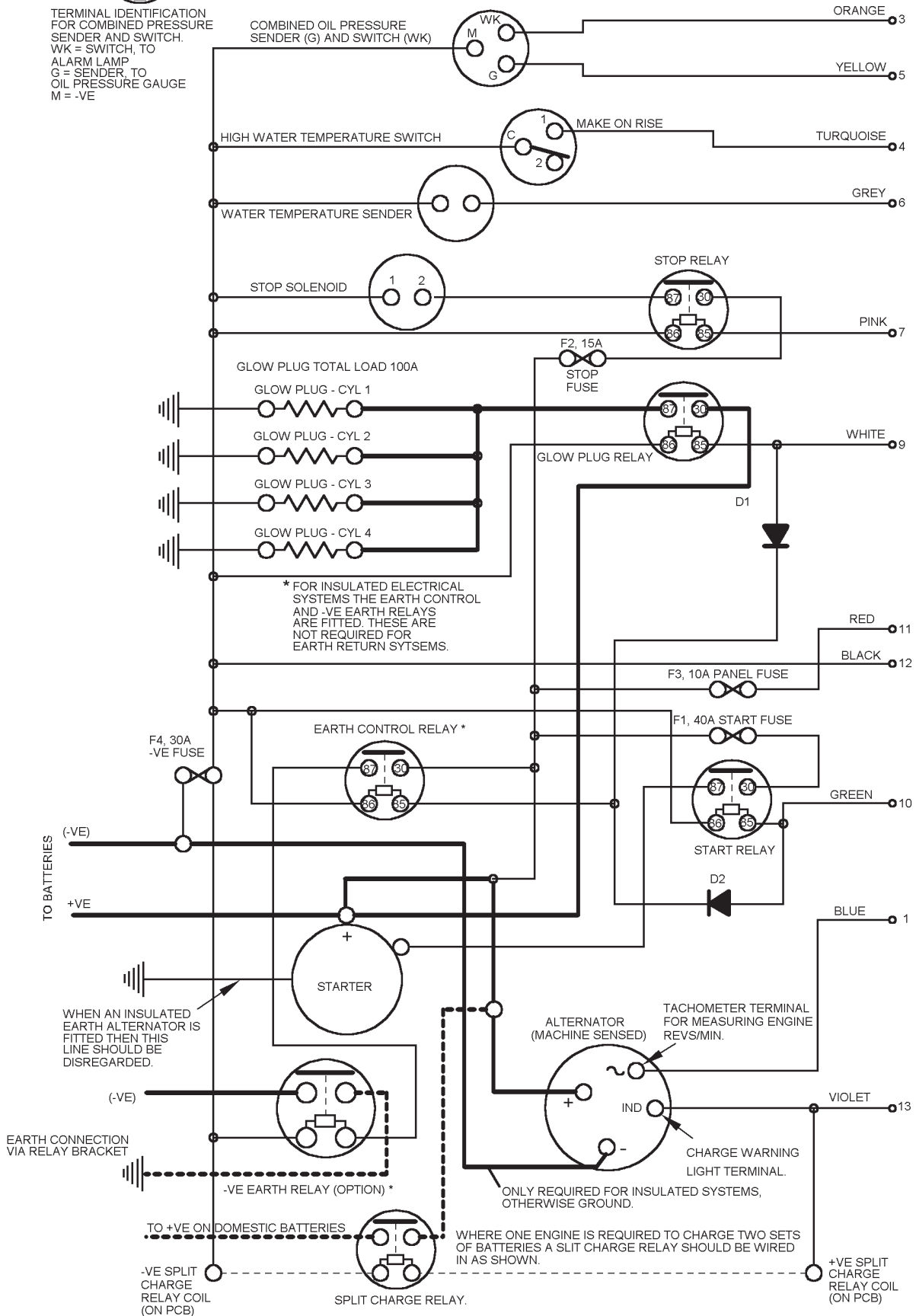

29M85

Fuseboard

Note: Fuses are provided to protect the wiring from accidental short circuits. This risk is highest when the engine is being installed, or when additional equipment is wired in, and is negligible during normal operation.

The location of the Fuseboard on the engine is shown on (A1), and the fuse layout is shown on (B), where:-

(B1) is a 40A fuse protecting the starter relay circuit

(B2) is a 15A fuse protecting the stop solenoid circuit

(B3) is a 10A fuse protecting the supply to the instrument panel(s)

(B4) is a 30A fuse protecting the negative wires in the loom

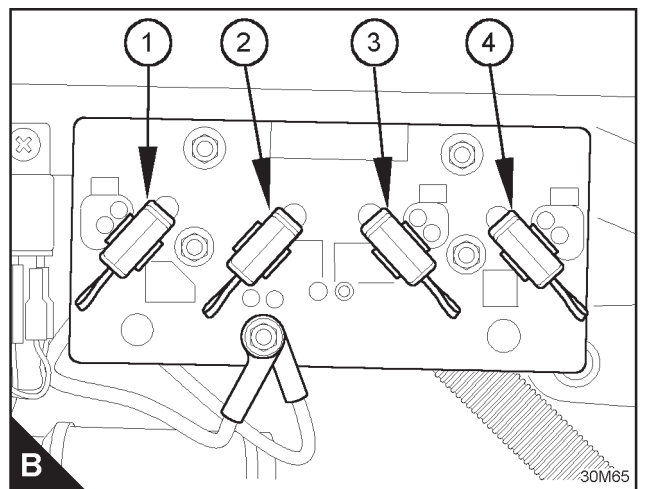
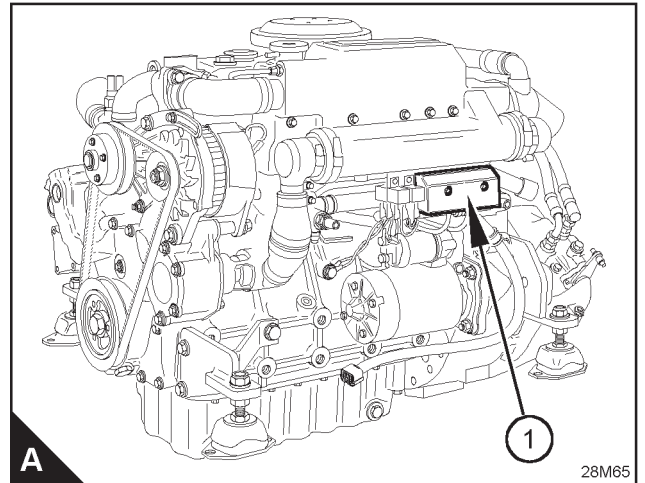

Interconnecting cables and 'Y' harness

Interconnecting cables (A) are used to join the engine loom to the instrument panel(s). Cables are made in 4m and 6m lengths and all cables have a male plug (A1) at one end and a female (A2) at the other. Cables may be plugged together to give up to 12m length, but in general if a longer cable is required it should be ordered as a special item, to be made in one piece.

A 'Y' harness (B) is available, with a male plug at (B1) and two female plugs (B2). If necessary, more than one 'Y' harness may be used, to connect several instrument panels together.

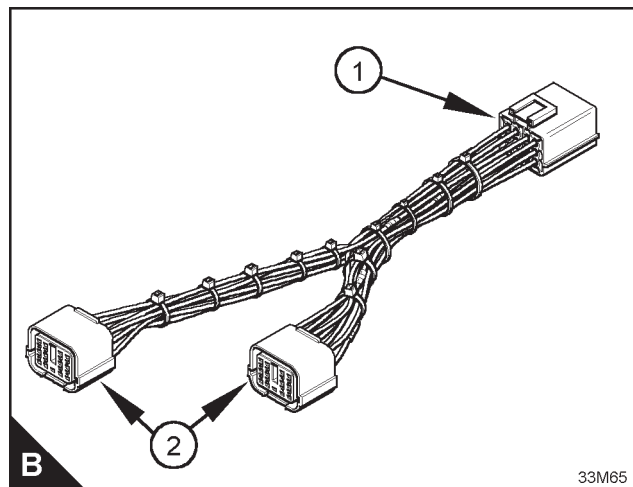
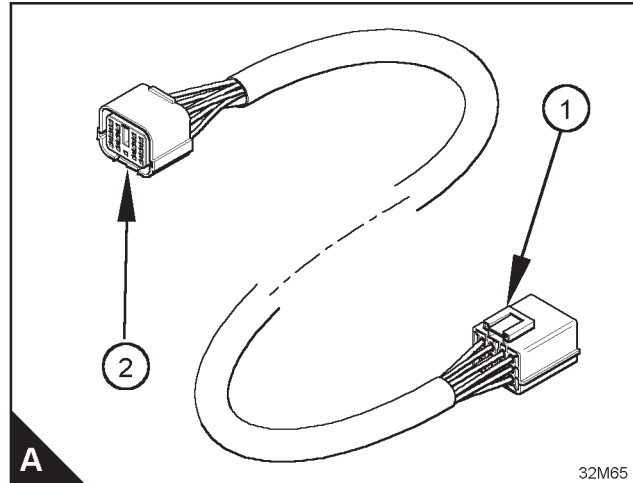

Instrument panels

Two types of panel are available, providing different levels of instrumentation. The 'Instrument Panel' shown on (A) includes:-

- Tachourmeter
- Low oil pressure warning lamp
- High water temperature warning lamp
- Charge warning lamp
- Heat/start switch
- On/off switch
- Stop switch
- Oil pressure gauge
- Water temperature gauge
- Voltmeter
- Water in fuel warning lamp
- Panel illumination level switch

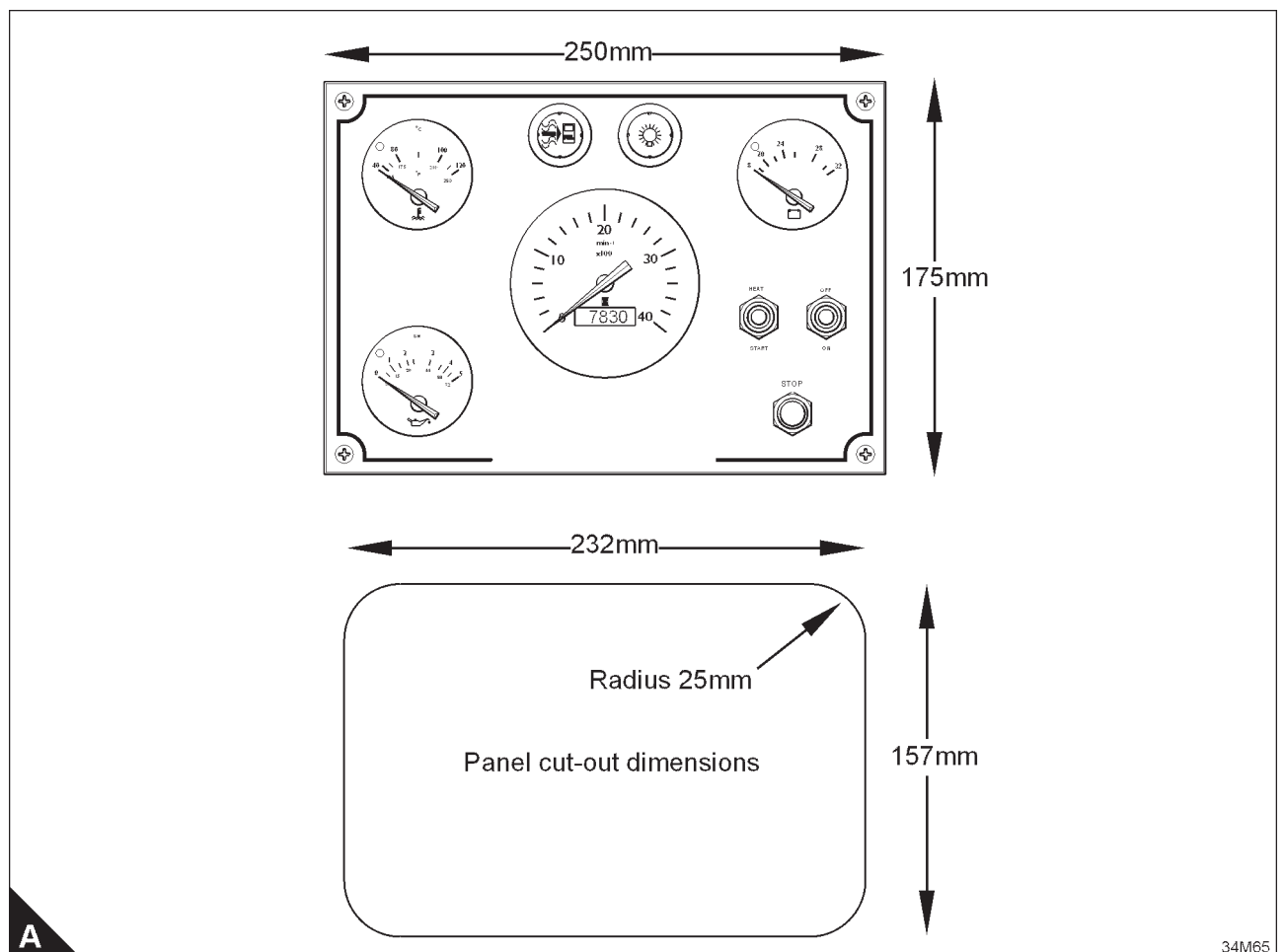

A

34M65

The 'Control Panel' shown on (B) includes:-

- Tachourmeter
- Low oil pressure warning lamp
- High coolant temperature lamp
- Charge warning lamp
- Heat/start switch
- On/off switch
- Stop switch

Up to three panels may be run simultaneously, in any combination (C)

Circuit diagrams for both types of panel are shown on page 27 and on page 28.

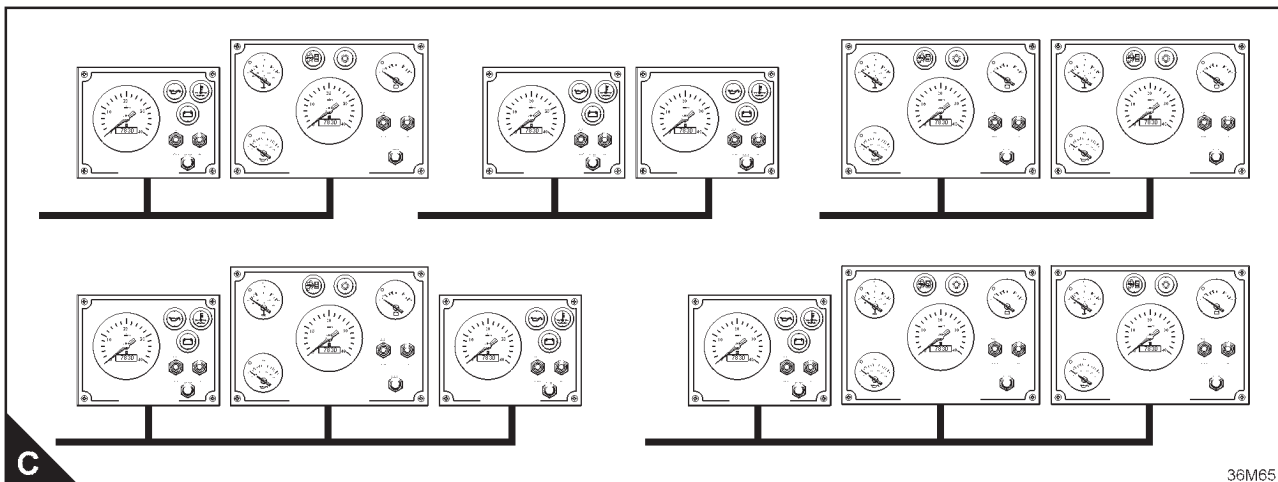
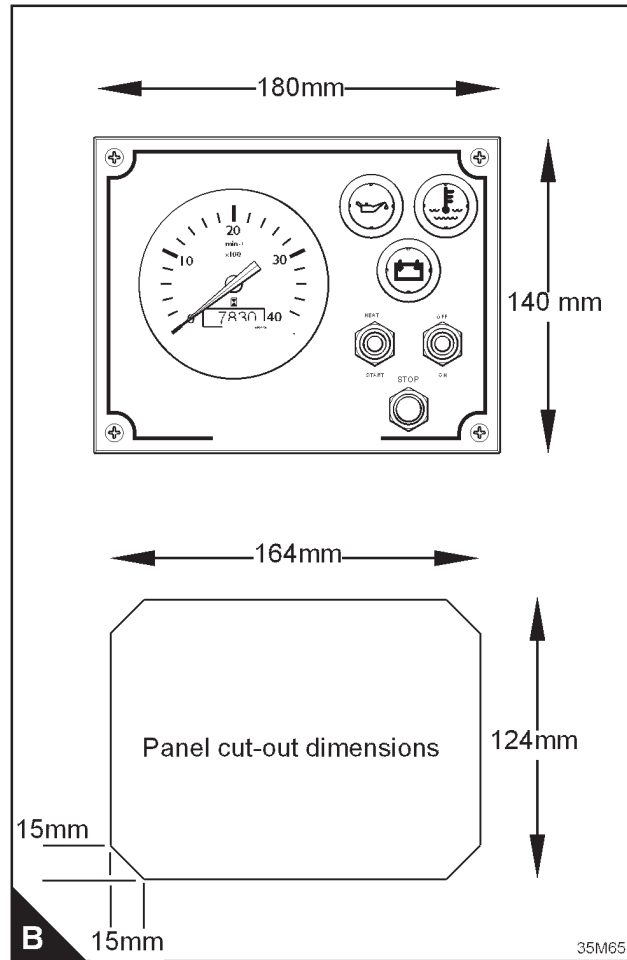

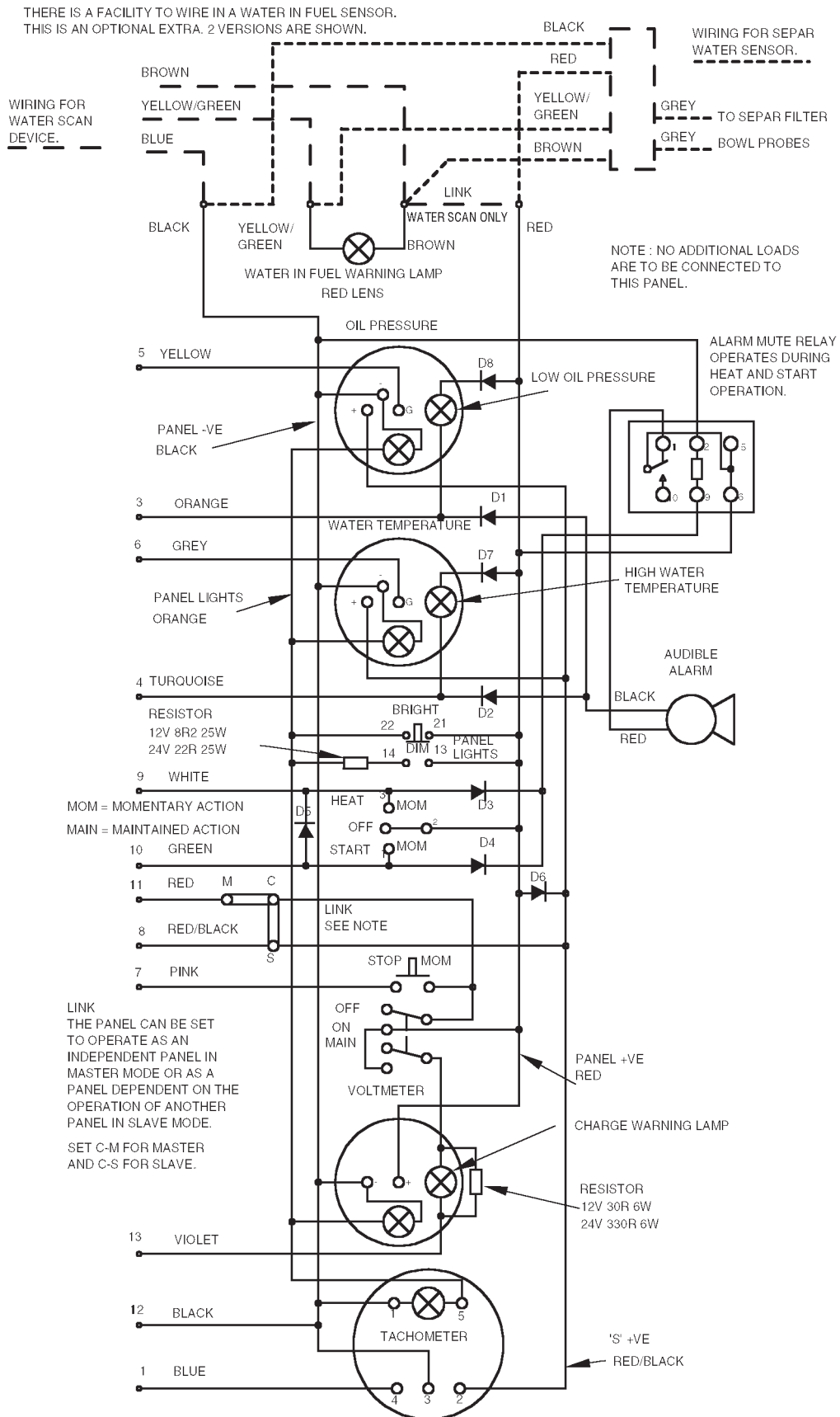

INSTRUMENT PANEL WIRING DIAGRAM 98-1043-3

37M65

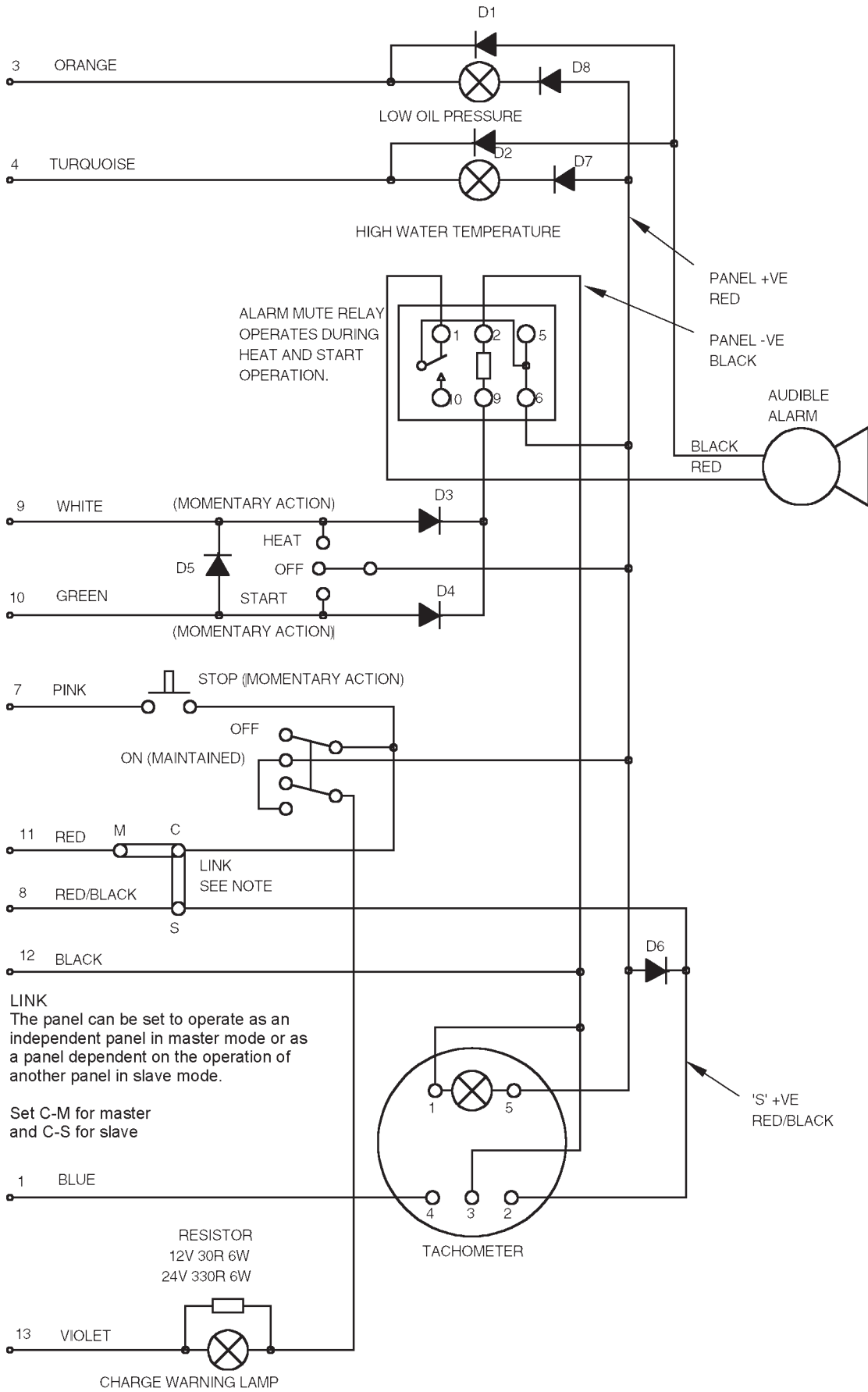

CONTROL PANEL WIRING DIAGRAM 98-1055-3

38M65

Starter battery

The performance of starter batteries is commonly expressed by the current in amperes that they will supply under specified conditions.

A suitable battery for the M65 and M85T, if specified by BS3911, will supply a minimum current of 340A (for 60 seconds, with the voltage not falling below 8.4v, at minus 18°C).

A similar battery, specified by SAE J537, will supply a minimum current of 540A (for 30 seconds, with the voltage not falling below 7.2v at minus 18°C).

If auxiliary loads are considerable, an additional battery should be fitted, with a split charge relay as shown on page 22. This will ensure that the engine starting battery is kept in a good state of charge at all times.

Starter cables

The total resistance of the two leads from the battery to the engine should not exceed 0.0017 ohms. In practice, this means that the total length of the starter cables (positive and negative) should not exceed 6 metres if the commonly available 61/044 cable is used. Longer cable runs, which should be avoided if possible, will require either double cables or a heavier cable, in order to comply with the total resistance of 0.0017 ohms.

Mounting the batteries close to the starter is very much the preferred option.

Grounding the battery negative

It is recommended that the battery negative busbar should be grounded as close as possible to the battery, by a substantial connection to the bonding system within the boat. This will reduce the likelihood of interference between items of electrical and electronic equipment fitted to the boat.

Zinc Anode Bonding System

Caution: The engine may be damaged by electrolytic corrosion if the correct bonding procedure is not adopted. Please read the guidelines below carefully.

Electrolytic corrosion within the engine cooling system and transmission can be much reduced or eliminated by bonding the engine to a Zinc anode which is used to protect the through hull metal fittings and other metal components that are in contact with sea water. The engine is fitted with a stud (A1) that may be used for this purpose which is identified by label (B)

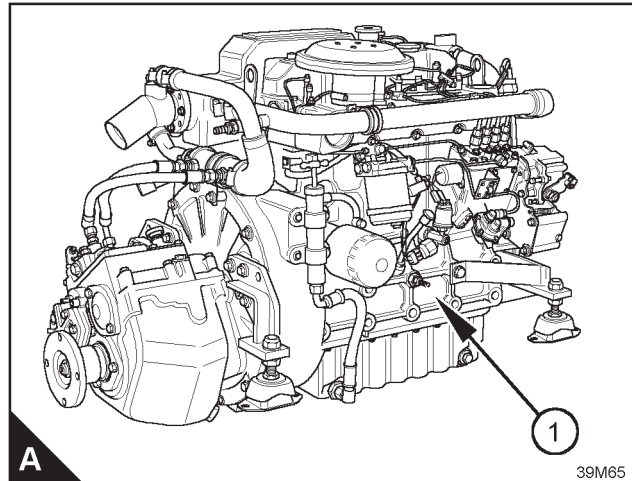

Typical System in Common Use

The bonding system in the boat (C) should provide a low resistance connection between all metals in contact with sea water, together with a connection to a Zinc sacrificial anode which is fixed to the outside of the hull (C1) below sea level.

The bonding should consist of heavy stranded wire(C2), (not braiding or wire with fine strands), connecting the Zinc anode (C3), propeller shaft (C4), sea cock (C5), through hull metal fittings (C6) and the engine bonding stud (C7) . It is an advantage if the wire is tinned. Insulation is also an advantage and should preferably be green in colour. Although the current carried by the bonding system will not normally exceed 1 amp, the cable sizes should be generous as shown in the table below:

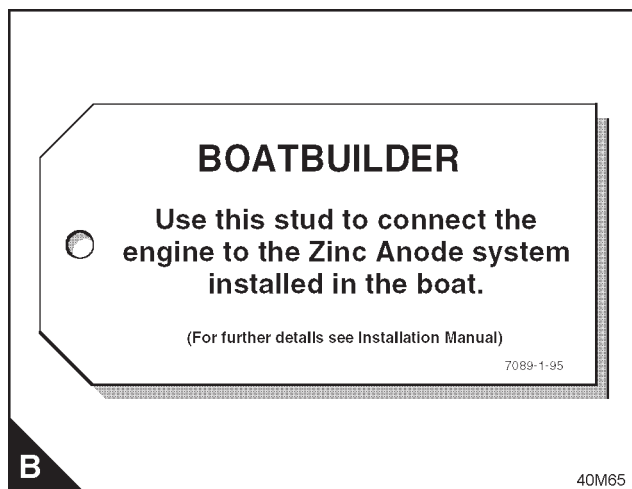

Length of run to Zinc Anode	Suggested cable size
Up to 30 feet	7 strand / 0.85mm (4mm ²)
30 - 40 feet	7 strand / 1.04mm (6mm ²)

As the connections may be splashed with sea water they should be soldered wherever possible and clamped elsewhere, with the joint protected from corrosion by neoprene paint, or a similar material, to exclude water.

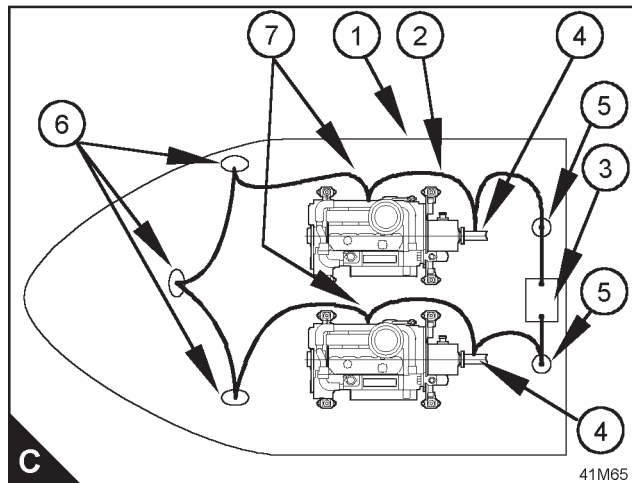

It is important to include the propeller shaft in the bonding system (A1), as the electrical path through the gearbox is not effective due to the gearbox oil acting as an insulator. The electrical connection to the shaft may be made by means of graphite brushes riding on the shaft or a braided battery strap (A2) which should make contact with 90° of the shaft circumference.

In either case the shaft earthing system should be connected to the bonding system (A3) to which the engine and the shaft log (if metal) are also connected.

Before the boat enters service the effectiveness of the bonding and sacrificial Zinc anode system should be tested, both when at rest and with all systems (including engines) in operation, by a specialist in this field.

Note: This section on bonding covers a typical system and has been included for guidance purposes only. It may not be appropriate for your boat. As installations vary it is advised that specific recommendations from a specialist in the subject of electrolytic corrosion are obtained.

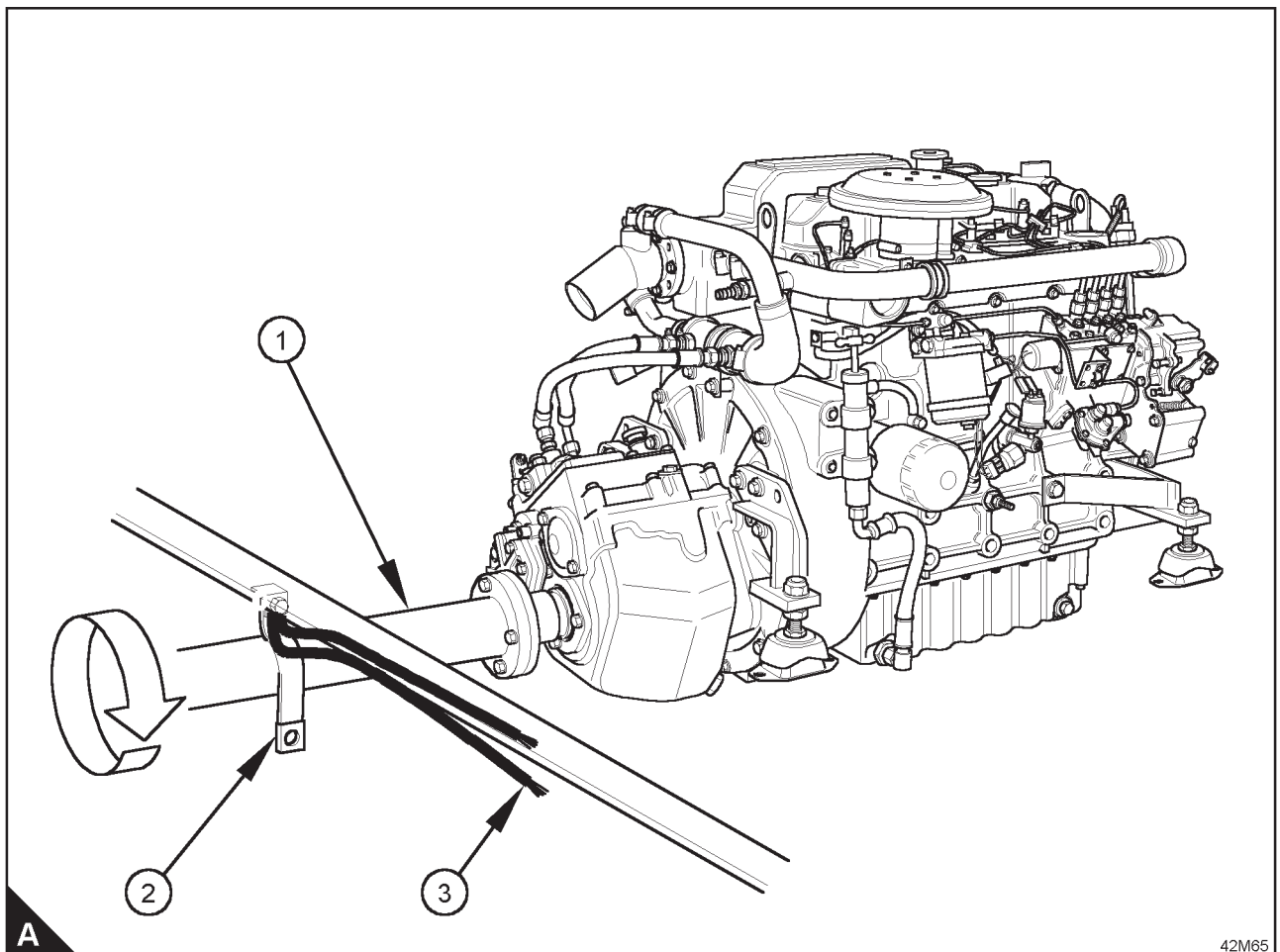

Engine controls

It is recommended that a Morse single lever system is used to regulate engine speed and to engage gear.

The speed selector lever (A3) which is shown in the idle speed position, may be operated by a Morse 33C cable using the anchor point (A2).

The stop solenoid (A1), which is energised to stop, is normally controlled from the instrument panel, but the engine may be stopped manually by pushing in the plunger (A4). The illustration shows the plunger in the run position.

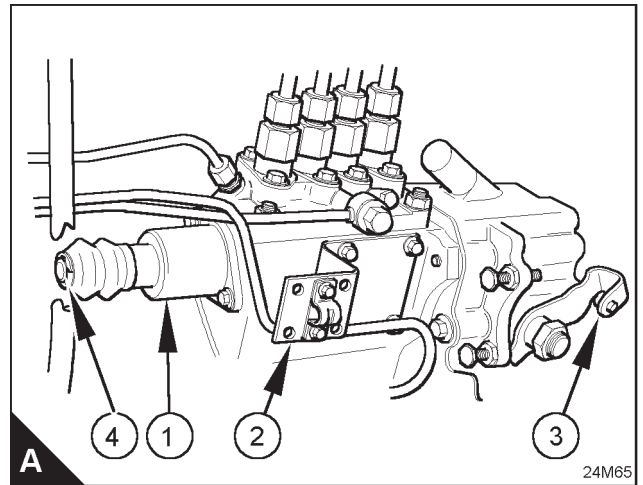

Provision for Power Take-Off

Additional equipment may be driven from the crankshaft nose, as advised below.

- Axial loads (i.e. involving no side load on the crankshaft nose).

The cranknose and pulley fixing arrangement is capable of transmitting up to full engine power (subject to engine and drive line rotating inertias). For a rigidly connected PTO the maximum inertia of the PTO drive arrangement and crank pulley should not exceed 0.01 kgm². In practice this means that axially driven machinery should have a flexible coupling with appropriate characteristics in the drive line. Seek advice from Wimborne Marine Power Centre if you are considering axially driven equipment.

- Belt Driven Loads

Loads of up to 8kw may be driven by belts, providing that the side force is applied at a point not more than 113mm from the cylinder block front face. Pulleys are available to meet this requirement.

Part 34131 has a single 'A' section groove of 143mm O.D. (137mm PCD.) and is shown on A.

Part 34132, shown on B, has four 'A' section grooves:-

- 2 at 195mm O.D. (189mm PCD)
- 1 at 152mm O.D. (146mm PCD)
- 1 at 106mm O.D. (100mm PCD)

As a rule of thumb the maximum power offtake should not exceed 2kw per belt.

Engines can be specified with PTO driven equipment already mounted, including second alternators, bilge pumps, and refrigerator pumps.

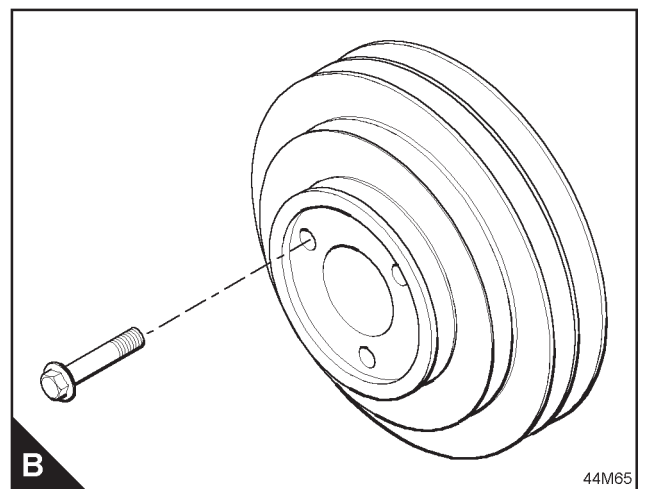
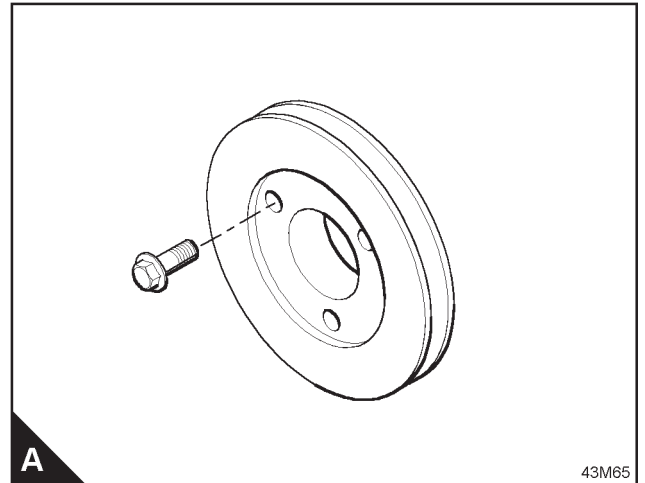

PTO Fitting Instructions

Key	Size	Torque
1	M12	100 Nm
2	7/16"	70 Nm
3	M10	55Nm

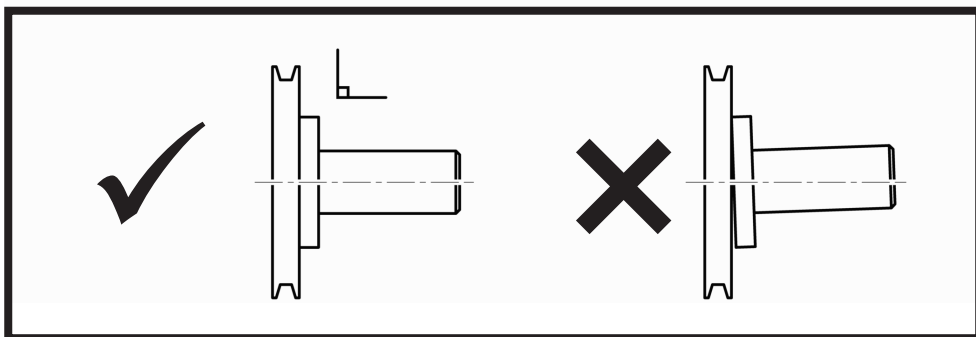
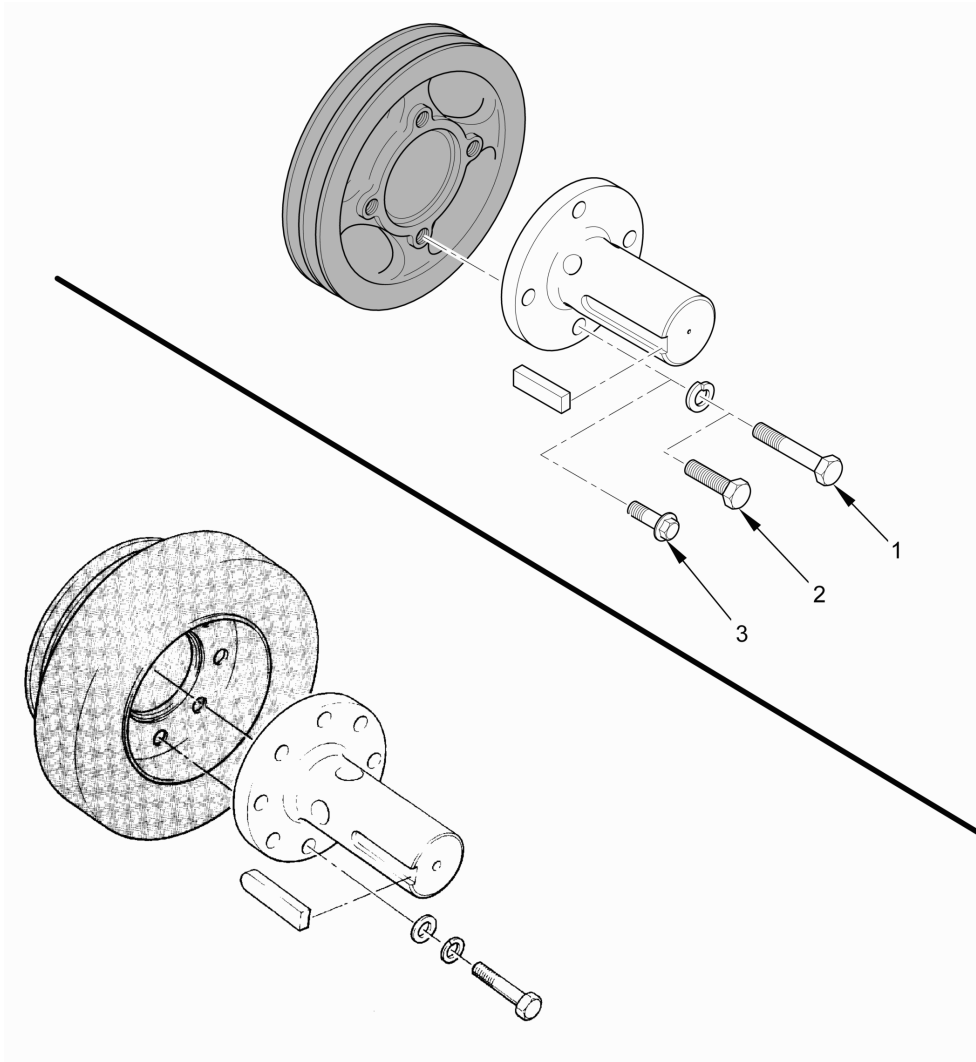

Note: Fitting the PTO should be undertaken by a qualified marine engineer.

Warning! For safety reasons, all moving parts should be shielded by a guard.

Electro Mechanical Bilge Pump

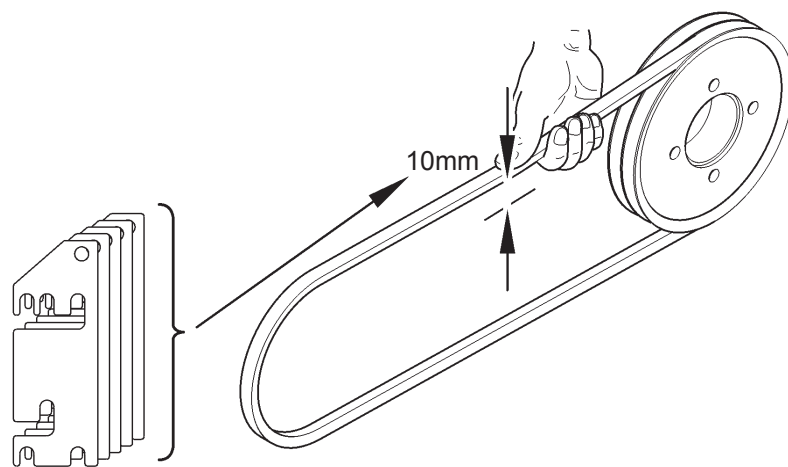
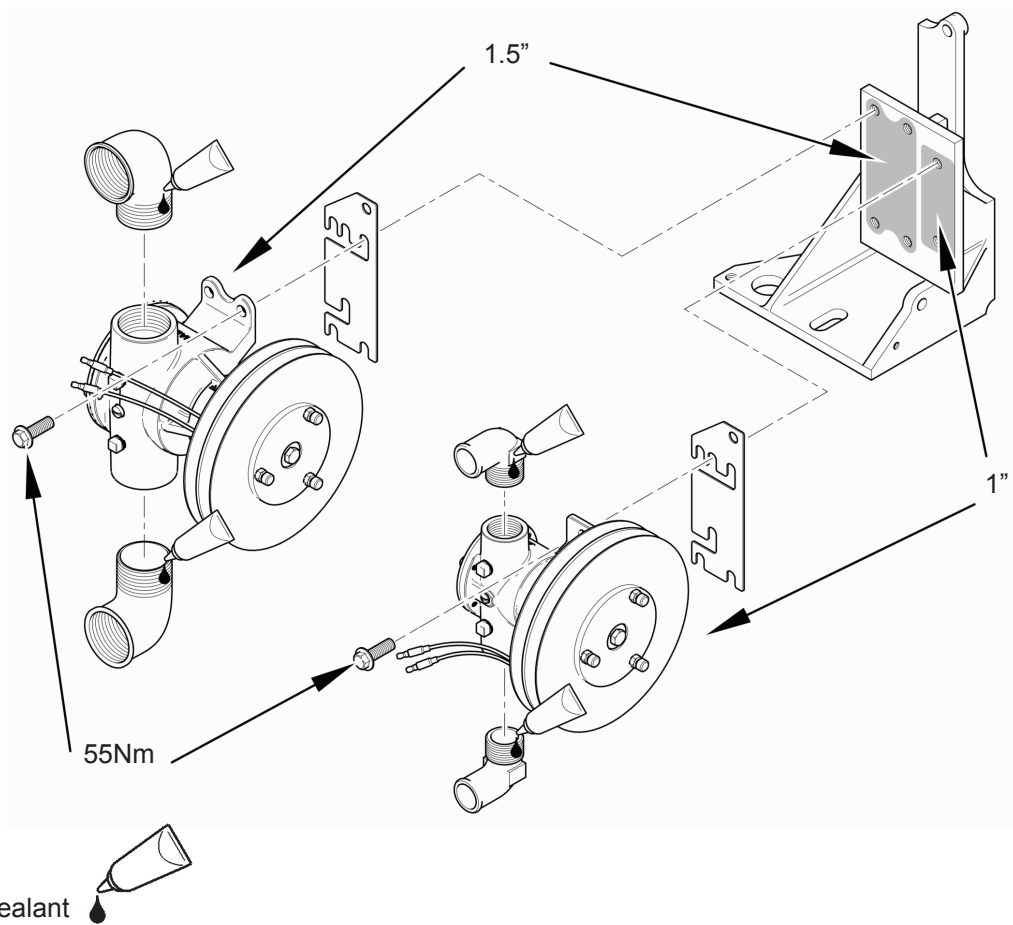

Note: Fitting the electro mechanical bilge pump should be undertaken by a qualified marine engineer.

Warning! For safety reasons, all moving parts should be shielded by a guard.

Calorifier Connections

Fittings may be specified to allow a calorifier to be connected to the engine. The fittings may be ordered as part of the engine assembly, or as loose parts to be installed later. The position of the connection for the flow to the calorifier is shown on (A1), and the return on (B1). Both are for 1/2 inch bore hose, which should be of radiator or heater hose quality, and must be installed so that chafing will not occur. A shut-off valve is part of each fitting.

Caution: *The hoses connecting the engine to a calorifier are part of the closed engine system. Failure of a hose will lead to the engine overheating!*

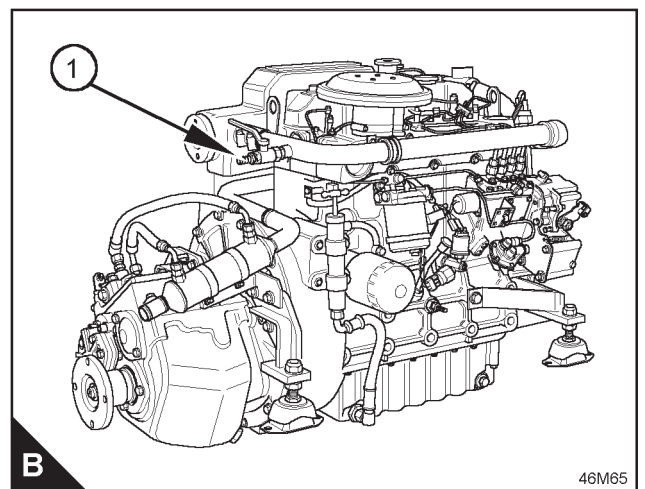
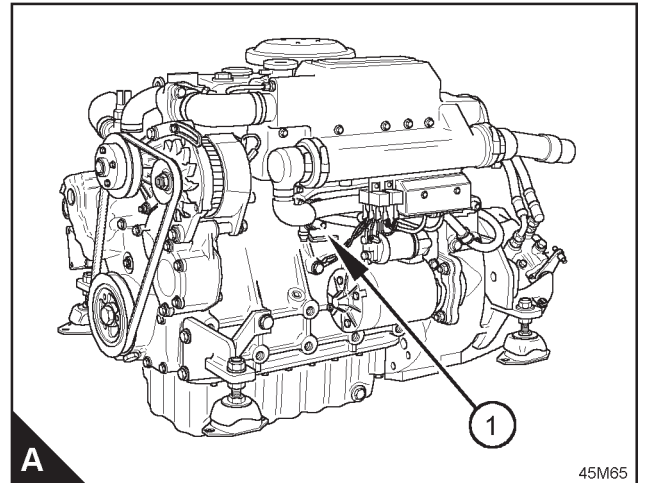

Reference data

Basic technical data

	M65	M85T
Rated power	43.5 kW (63 bhp)	60 kW (80.5 bhp)
Rated engine speed	2600 rev/min	2600 rev/min
Number of cylinders.....	4	4
Cylinder arrangement.....	In-line	In-line
Cycle.....	4 stroke	4 stroke
Induction system.....	Naturally aspirated	Turbocharged
Combustion system.....	Direct injection	Direct injection
Bore	97 mm (3.82 in)	97 mm (3.82 in)
Stroke	100 mm (3.94 in)	100 mm (3.94 in)
Compression Ratio	17.5:1	17.5:1
Cubic Capacity	2.955 litre (183 in ³)	2.955 litre (183 in ³)
Direction of rotation	Clockwise viewed from front	Clockwise viewed from front
Firing order	1,3,4,2	1,3,4,2
Total weight (wet).....	263 kg (579 lb) engine only including electrics	291 kg (642 lb) engine only including electrics

Cooling system

Recommended coolant inhibitor	Perkins Powerpart anti-freeze	Perkins Powerpart anti-freeze
Fresh water flow	130 litre/min (28.5 UK gal/min, 34.2 US gal/min) at 2600 rev/min	130 litre/min (28.5 UK gal/min, 34.2 US gal/min) at 2600 rev/ min
Coolant pump speed and method of drive	1.25:1 ratio, belt drive	1.25:1 ratio, belt drive
System capacity	8.75 litres (1.92 UK gal, 2.31 US gal)	9.5 litres (2.07 UK gal, 2.48 US gal)
Pressure cap setting.....	50 kPa (7 lb/in ²)	50 kPa (7 lb/in ²)
Protection switch setting.....	96°C (204°F)	96°C (204°F)
Sea water pump type.....	Jabsco gear driven model 19 mm 3/4 cam	Jabsco gear driven model 19 mm 3/4 cam
Sea water suggested inlet hose internal diameter	32 mm (1.25 in)	32 mm (1.25 in)
Minimum sea cock size	Full flow 25.4 mm (1 in)	Full flow 25.4 mm (1 in)
Sea water strainer	A raw water strainer must be included in suction side of the circuit	A raw water strainer must be included in suction side of the circuit
Maximum sea water temperature..	38°C (100°F)	38°C (100°F)

Fuel system	M65	M85T
Recommended fuel specification...	BS2869 Class A2 ASTM D975 Number 2D	BS2869 Class A2 ASTM D975 Number 2D
Fuel injection pump	Zexel PTR, in-line pump	Zexel PTR, in-line pump
Stop solenoid		
• Early engines to		
January 1999	Energise-to-run	
Later engines	Energise-to-stop	Energise-to-stop
Fuel lift pump	FCM type XY - lever operated diaphragm pump	FCM type XY - lever operated diaphragm pump
Fuel feed pressure (static).....	42 - 70 kPa (6.1 - 10.2 lbf/in ²)	42 - 70 kPa (6.1 - 10.2 lbf/in ²)
Governor type	Mechanical	Mechanical
Pipe sizes		
Fuel feed pipe -		
outside / diameter	7.9 mm (0.315 in)	7.9 mm (0.315 in)
Fuel feed pipe - bore	6.53 mm (0.257 in)	6.53 mm (0.257 in)
Return fuelpipe -		
outside / diameter	6.3 mm (0.25 in)	6.3 mm (0.25 in)
Return fuel pipe - bore	4.93 mm (0.194 in)	4.93 mm (0.194 in)
Maximum lift pump lift	1.53 m (5 ft) to bottom of fuel tank	1.53 m (5 ft) to bottom of fuel tank
.....	suction pipe through a pipe 3.06 m (10 ft) in length	suction pipe through a pipe 3.06 m (10 ft) in length
Maximum fuel lift pump depression at Inlet	120 mm Hg (4.72 in Hg)	120 mm Hg (4.72 in Hg)
Fuel lift pump flow rate	9.15 cc/sec at delivery pressure of 24 kPa (3.5 lbf/in ²)	9.15 cc/sec at delivery pressure of 24 kPa (3.5 lbf/in ²)
Fuel consumption at full power.....	13.31 litre/hr (2.9 UK gal/hr, 3.52 US gal/hr)	16.5 litre/hr (3.7 UK gal/hr, 4.5 US gal/hr)

Air intake

M65

M85T

Combustion air flow	3.0 m ³ /min (106 ft ³ /min)	5.2 m ³ /min (184 ft ³ /min)
Maximum engine compartment air temperature	60°C (140°F)	60°C (140°F)
Maximum air temperature at engine inlet	52°C (126°F)	52°C (126°F)
Ventilation - maximum engine room depression	125 mm WG (5 in WG)	125 mm WG (5 in WG)
Suggested ventilation airflow including combustion air	7m ³ /min (247ft ³ /min)	10.4m ³ /min (360ft ³ /min)
Minimum cross-section of air duct (per engine)	206 cm ² (31.9 in ²) 103 cm ² (16 in ²)	Hot 260 cm ² (40.3 in ²) Temperate 130 cm ² (20.1 in ²)

Exhaust system

Exhaust gas flow	4.1 kg/min (120.8 ft ³ /min)	16.4 kg/min (471 ft ³ /min)
Maximum restriction measured within 305 mm (12 in) of outlet at maximum rated speed	10.2 kPa (3.0 in Hg)	10.2 kPa (3.0 in Hg)
Recommended exhaust pipe bore (wet exhaust system).....	63.5 mm (2.5 in)	76 mm (3.0 in)
Recommended exhaust pipe bore (dry exhaust system)	40 mm (1.6 in)	63.5 mm (2.5 in)
Minimum rise from sea water level to exhaust outlet centre line	203 mm (8 in)	203 mm (8 in)

Lubricating oil system	M65	M85T
Recommended lubricating oil	API CD/SE CCMC D4	API CD/SE CCMC D4
Sump capacity maximum (standard sump)	8 litres maximum (14 UK pints, 8.5 US quarts)	8 litres maximum (optional) (14 UK pints, 8.5 US quarts)
.....	6 litres minimum (10.6 UK pints, 6.3 US quarts)	6 litres minimum (10.6 UK pints, 6.3 US quarts)
Sump capacity maximum (high inclination sump).....	8 litres maximum (14 UK pints, 8.5 US quarts)	8 litres maximum (standard)
.....	6 litres minimum (10.6 UK pints, 6.3 US quarts)	6 litres minimum (10.6 UK pints, 6.3 US quarts)
Maximum installation angle plus planing angle for continuous operation	20° engine front up	20° engine front up
Heel angle to port or starboard (standard sump)	20° continuous, 25° intermittent	20° continuous, 25° intermittent (optional)
Heel angle to port or starboard (high inclination sump).....	25° continuous, 35° intermittent	25° continuous, 35° intermittent (standard)
Oil pressure in operating speed range.....	280 kN/in ² (40 lb/in ²)	280 kN/in ² (40 lb/in ²)
Low oil pressure switch setting.....	83 kN/in ² (12 lb/in ²)	83 kN/in ² (12 lb/in ²)
Electrical system		
Alternator type (earth return system)	Magneti Marelli (12V-65A) A127.	Magneti Marelli (12V-65A) A127.
.....	Perkins Pt 2871A166	Perkins Pt 2871A166
Alternator type (insulated return system).....	Prestolite (12V-70A) A127 Perkins Pt 40082	Prestolite (12V-70A) A127 Perkins Pt 40082
Starter Motor type (earth return system)	Magneti Marelli 12V, 2M113 Perkins Pt 2873A103	Magneti Marelli 12V, 2M113 Perkins Pt 2873A103
Starter Motor type (insulated return system).....	As above	As above
Number of teeth on flywheel.....	112	112
Number of teeth on starter motor ..	10	10

Cold Start Limits

M65

M85T

Minimum cold start temperature

With glow plug aid -15°C (5°F)

-15°C (5°F)

Without aid -5°C (23°F)

-5°C (23°F)

Batteries 1 x 12 volt 540 amp SAE
(340 amp IEC)

1 x 12 volt 540 amp SAE
(340 amp IEC)

Power Take Off

Axial power take-off from

front of crankshaft pulley Full load throughout the
engine speed range

Full load throughout the
engine speed range

Belt driven auxiliaries from crankshaft

power take-off pulley See section 9, or for technical
assistance contact
Wimborne Marine Power Centre

See section 9, or for technical
assistance contact
Wimborne Marine Power Centre

California

Proposition 65 Warning

Diesel engine exhaust and some of its constituents are known to the State of California to cause cancer, birth defects, and other reproductive harm.



Perkins®
Marine Power

All information in this document is substantially correct at time of printing and may be altered subsequently.

Part No. TPD 1399E issue 7

Produced in England ©2013 by Wimborne Marine Power Centre

Wimborne Marine Power Centre
22 Cobham Road,
Ferndown Industrial Estate,
Wimborne, Dorset, BH21 7PW, England.
Tel: +44 (0)1202 796000,
Fax: +44 (0)1202 796001
E-mail: Marine@Perkins.com

Web: www.perkins.com/Marine