

415F2

Backhoe Loader



Engine

Engine Model	Cat® C3.4B	
Rated Net Power – SAE J1349	51 kW	68 hp
Rated Net Power – ISO 9249	51 kW	68 hp

Weights

Operating Weight – Minimum	6898 kg	15,207 lb
Operating Weight – Maximum (ROPS Capacity)	11 000 kg	24,251 lb

Backhoe

Dig Depth – Standard	4348 mm	14'3"
Dig Depth – E-Stick Extended	5441 mm	17'11"

Features

All New Operator Station

Built with the operator in mind, the new F2 Backhoe Loader cab provides additional machine control at the operator's fingertips, with differential lock on the loader joystick. The ergonomically designed cab provides all day comfort for a more productive day.

Industry Leading Hydraulic Technology

Load sensing piston pump and flow sharing valves provide a hydraulic system designed for smooth operation, increased fuel efficiency, quieter operation and full forces at any engine speed allowing the operator to match power to job demand.

Backhoe Controllability

Now available in pilot controlled joysticks, the F2 Backhoe Loader maximizes the hydraulic performance and power of the loading sensing, flow sharing system.

Greater Versatility

Quick and easy attachment changing provides increased versatility and the ability to match the correct tool to the job application. The hydraulic backhoe coupler allows for a tool change without exiting the operation station.

Superior Power and Performance

Industry leading structural design and hydraulics mean greater lifting power and breakout forces. Machine aggressiveness delivers outstanding productivity in the toughest applications.

Contents

Operator Station.....	4
Power Train.....	6
Advanced Hydraulics.....	7
Backhoe Performance.....	8
Loader Performance.....	8
Work Tools.....	9
Serviceability.....	10
Customer Support.....	10
Specifications.....	11
Standard Equipment.....	19
Optional Equipment.....	20
Notes.....	21





Experience the new Cat 415F2 Backhoe Loader with features including spacious operator station, optional pilot controls, superior durability and outstanding performance. Safely operate on the job site with quieter hydraulics, increased visibility, and the ability to have four wheel braking engaged without wearing on tires or drive train.

Operator Station

A cab designed for maximum comfort and productivity.



Backhoe Controls

Mechanical controls provide the feedback operators look for in trenching applications. Low effort hydraulics reduce operator fatigue while maintaining performance. Optional joystick controls allow the operator to customize the pod location and control pattern.



Unmatched Comfort

The ergonomic, automotive style operator station helps you work comfortably and productively all day long. Choose the configuration that meets your needs – Canopy, Cab Deluxe or Cab Deluxe with Air Conditioning. Other features include:

- Adjustable air suspension seat
- Tilt steering column
- Excellent visibility over hood and up to bucket dump
- Pantograph windshield wiper
- Large front windshield screen
- Large LCD gauge cluster screen
- Ample legroom
- Differential lock button on loader lever
- Large opening windows
- Solid roof cab
- LED brake lights

Ride Control

The optional Ride Control System smooths the ride in all conditions, including load and carry, highway roading or simply moving around the job site. The result can be increased operator comfort, potentially reducing operator fatigue, and improved material retention.

Premium Gauge Cluster

Bright and large LCD screen makes it easy to monitor machine operation and settings. LED indicator lights and audible alarms allow the machine to clearly communicate with the operator.

Safety Getting in and out of the Cab

New longer grab handles and ergonomic step placement makes it easy to maintain three points of contact when getting in and out of the cab.





Power Train

Always built for performance, power and efficiency.

Cat Engine

The Cat C3.4B engine delivers 55 kW (68 hp) and meets U.S. EPA Tier 4 Final emission standards, without the addition of Diesel Exhaust Fluid (DEF).

Engine features include:

- Diesel oxidation catalyst
- Diesel particulate filter
- Limited operator interaction

Transmission

The standard power shuttle transmission provides four speeds forward and reverse. Hydraulically shifted clutches allow on-the-go direction and travel speed shifts.

- Hydraulic proportional control valves deliver smooth speed and directional shifts.
- Four Wheel Drive option improves mobility and loader performance in poor underfoot conditions and can be activated on-the-go.

Brake Mode Selector

Brake mode selector switch has three positions: two wheel drive, two wheel drive with all wheel braking and four wheel drive. Two wheel drive with all wheel braking provides better tire life while roading and engages the front axle when brakes are applied for improved braking performance. Brake mode selector is included in the 4WD package.

Advanced Hydraulics

Matching system power to job site demands.



Load Sensing Hydraulics

Closed center hydraulic system matches pressure and flow to application demand. Whether you're in full trenching mode or digging around delicate services, you remain in control. In applications such as production trenching where speed is important, the system will provide the flow needed to get the job done quickly and efficiently. The load sensing hydraulic system provides:

- Better fuel efficiency
- Quieter operation
- Reduced component wear
- Cooler hydraulic temperatures
- Full forces at any engine speed

Flow Sharing Valves

Specifically tuned hydraulic valves allow for the multifunction of hydraulic components, without machine manipulation. Hydraulic fluid is shared between implements so that operation isn't interrupted.

Hydraulic Lines

Combination two way and one way flow hydraulic lines add versatility to the machine. By simply changing the lever position, the machine can efficiently run either style hydro mechanical tool.



Backhoe Performance

Superior digging forces.

Boom

The excavator-style boom is built for optimum performance and durability. The curved design provides added clearance when digging over obstacles or loading trucks. The narrow boom enhances the viewing area to the bucket and the trench throughout the operating range. More robust swing casting and double clevis design improves durability and reliability.

Stick

Serrated edges on the stick provide improved material clamping for clearing and demolition applications. The optional extendible stick (E-stick) increases reach and dig depth by approximately 1.2 m (4 ft).

Thumbs

Thumb mounting provisions are standard on every Cat Backhoe Loader for added machine versatility. Cat hydraulic thumbs are available for even greater versatility. Mechanical thumbs are also available through your Cat dealer.

Loader Performance

Powerful front loader.

Front loader arms deliver more reach, dump height and breakout.

Single Tilt

The standard single tilt loader linkage features strong lift and breakout forces for solid performance in backfilling and truck loading applications with pin-on buckets. The 415F2 is equipped with either a general purpose or multi-purpose pin-on bucket to meet your specific needs.

Return-to-Dig

The return-to-dig system reduces loading cycle times by bringing the loader bucket back to the dig position with an easy pull of the lever. By the time the loader bucket is at ground level, the bucket is angled correctly for the next load or cut.

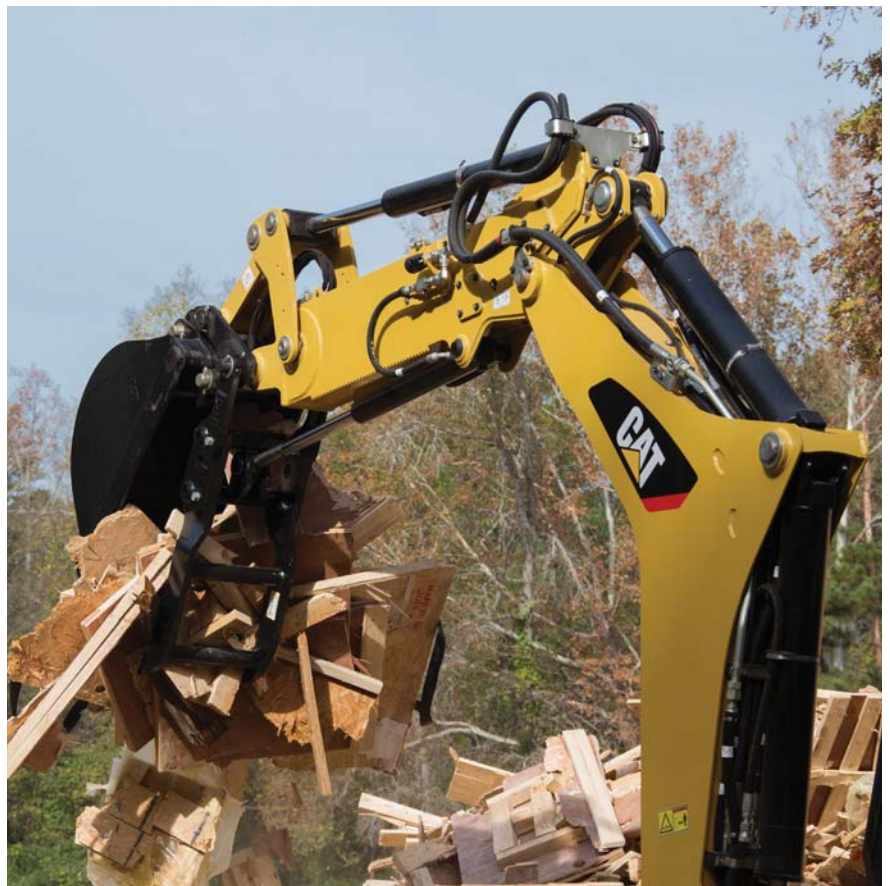



Work Tools

Do more jobs with one machine.

Backhoe Work Tools

Increase the versatility of your machine with the large selection of backhoe attachments:

- Buckets – Standard Duty, Heavy Duty, Heavy Duty Rock, Soil Excavation, Coral and Ditch Cleaning
- Cold Planers
- Hammers
- Augers
- Rippers
- Thumbs (mechanical and hydraulic)
- Vibratory Plate Compactors
- Quick Couplers

Loader Work Tools

A wide range of loader attachments is available including:

- General Purpose Bucket
- Multi Purpose Bucket
- Side Dump Bucket
- Forks

Diagonal Retention System

Heavy duty bucket teeth are attached with diagonal pins rather than horizontal pins for easy exchange without the use of special tools.

Backhoe Quick Coupler

Manual or hydraulic backhoe couplers make rear tool exchange quick and easy. New Cat dual lock coupler has a self-adjusting wedge design to ensure a tight fit. It also features a safety lock that automatically engages.



Serviceability

Easy maintenance helps keep your machine working.



Minimize Your Downtime

Convenient service features make maintenance easy, reducing your downtime:

- Hinged cooling pack provides easy access
- Tilt up hood provides easy, convenient access to all engine check points
- Engine side panels remove easily without the use of tools
- Cat Product Link™ system (optional) provides remote reporting of machine location and operating system parameters

Customer Support

Unmatched support makes the difference.

Renowned Dealer Support

From helping you choose the right machine to knowledgeable ongoing support, Cat dealers provide the best in sales and service.

- Preventive maintenance programs and guaranteed maintenance contracts
- Best-in-class parts availability
- Operator training to help boost your profits
- Genuine Cat Remanufactured parts



Engine

Engine Model	Cat C3.4B	
Gross Power		
SAE J1995	55 kW	74 hp
ISO 14396	55 kW	74 hp
Rated Net Power @ 2,200 rpm		
SAE J1349	51 kW	68 hp
ISO 9249	51 kW	68 hp
EEC 80/1269	51 kW	69 hp
Net Peak Power @ 1,800 rpm		
SAE J1349	55 kW	72 hp
ISO 9249	55 kW	73 hp
EEC 80/1269	56 kW	73 hp
Bore	99 mm	3.90 in
Stroke	110 mm	4.33 in
Displacement	3.4 L	207 in ³
Net Torque Rise @ 1,400 rpm – SAE J1349	88%	
Net Peak Torque @ 1,400 rpm	416 N·m	307 lbf-ft

- Engine meets U.S. EPA Tier 4 Final emission standards.
- Net power ratings apply at 2,200 rpm when tested under the specified conditions for the specified standard.
- Net power advertised is the power available at the flywheel when the engine is equipped with fan, air cleaner, muffler and alternator.
- Based on standard air conditions of 25° C (77° F) and 99 kPa (29.32 in) in dry barometer.
- Used 35° API gravity fuel having an LHV of 42 780 kJ/kg (18,390 BTU/lb) when used at 30° C (89° F) (reference a fuel density of 838.9 g/L [7.001 lb/gal]).
- No derating required up to 3000 m (9,843 ft).
- Net torque rise meets SAE J1349.
- Net peak power ratings apply at conditions specified above.

Weights*

Operating Weight – Minimum	6898 kg	15,207 lb
Operating Weight – Maximum (ROPS Capacity)	11 000 kg	24,251 lb
Cab, ROPS/FOPS	163 kg	359 lb
Air Conditioning	46 kg	101 lb
Four Wheel Drive	178 kg	392 lb
MP Bucket (0.96 m ³ /1.25 yd ³) (no forks or teeth)	745 kg	1,642 lb
Extendible Stick	299 kg	659 lb
Counterweights (Option 1)	115 kg	255 lb
Counterweights (Option 2)	240 kg	530 lb
Counterweights (Option 3)	460 kg	1,015 lb

* Specifications shown are for machine equipped with OROPS canopy, 2WD, standard stick, 0.76 m³ (1.0 yd³) general purpose loader bucket, 610 mm (24 in) heavy duty backhoe bucket, 240 kg (550 lb) counterweight, 80 kg (176 lb) operator and full fuel tank.

Transmission

Power Shuttle Transmission – Standard

Forward – 1st	5.4 km/h	3.4 mph
Forward – 2nd	8.9 km/h	5.5 mph
Forward – 3rd	20 km/h	12 mph
Forward – 4th	36 km/h	23 mph
Reverse – 1st	5.4 km/h	3.4 mph
Reverse – 2nd	8.9 km/h	5.5 mph
Reverse – 3rd	20 km/h	12 mph
Reverse – 4th	36 km/h	23 mph

- Forward/reverse electric power shuttle is controlled by a conveniently placed, hand operated lever that provides instant direction changes between forward and reverse through power hydraulic clutches.
- Torque converter free-wheel clutch allows the converter stator to free-wheel during high speed, low torque conditions such as roading.
- Single-stage, 2.63:1 stall ratio.
- Travel speeds of two wheel drive backhoe loader at full throttle when equipped with 19.5 × 24 rear tires.

Axle Ratings

Front Axle, 2WD

Static	22 964 kg	50,582 lb
Dynamic	9186 kg	20,233 lb

Front Axle, 4WD

Static	22 964 kg	50,582 lb
Dynamic	9186 kg	20,233 lb

Rear Axle

Static	22 964 kg	50,582 lb
Dynamic	9186 kg	20,233 lb

Hydraulic System

Type	Closed Center	
Pump Type	Variable Flow, Axial Piston	
Pump Capacity @ 2,200 rpm	132 L/min	35 gal/min
System Pressure – Backhoe	23 000 kPa	3,336 psi
System Pressure – Loader	23 000 kPa	3,336 psi

Steering

Type	Front Wheel	
Power Steering	Hydrostatic	
Bore	65 mm	2.6 in
Stroke	120 mm	4.7 in
Rod Diameter	36 mm	1.4 in
Axle Oscillation	11°	
Turning Circle – 2WD/4WD (inner wheel not braked)		
Outside, Front Wheels	8.18 m	26'10"
Outside, Widest Loading Bucket	10.97 m	36'0"

415F2 Specifications

Service Refill Capacities

Cooling System with Air Conditioning	22 L	5.8 gal
Fuel Tank	160 L	42 gal
Engine Oil with Filter	8.8 L	2.3 gal
Transmission – Power Shuttle		
2WD	15 L	4 gal
4WD	15 L	4 gal
Rear Axle	16.5 L	4.4 gal
Planetarys	1.7 L	0.4 gal
Front Axle (4WD)	11 L	2.9 gal
Planetarys	0.7 L	0.2 gal
Hydraulic System	90 L	23.8 gal
Hydraulic Tank	40 L	10.6 gal

- Requires ultra-low sulfur fuel \leq 15 ppm fuel sulfur.

Tires

Choices listed as combination of front/rear tires:

- Front: 11L-16 (12 ply) F-3; Rear: 19.5L-24 (12 ply) R4 ATU
- Front: 12.5/80-18-1810 PR I-3; Rear: 19.5L-24 12 PR R4
- Front: 12-16.5 (10 ply); Rear: 19.5L-24 (12 ply) ATU
- Front: 12-16.5 (12 ply); Rear: 19.5L-24 (12 ply) ATU, 20 PITCH
- Front: 340-80R18 143B R-4; Rear: 500/70R24 157B, R-4
- Front: 340-80R18 143B R-4; Rear: 19.5L-24, 12, ATU
- Front: 340/80R18 XMCL 142A8; Rear: 500.70R24 XMCL 157A8

Standards

Brakes	SAE J/ISO 3450; ISO 3450 1996
Cab – ROPS	SAE J1040 MAY94; ISO 3741 1994
Cab – FOPS	SAE J/ISO 3449 APR98 LEVEL II and ISO 3449: 1992 LEVEL II
Cab – Sound	ANSI/SAE J1166 OCT98 is 79 dB(A)
Exterior Sound	SAE J188 JUN86 is 76 dB(A)

Engine Features

- Regeneration is passive and does not require any input from the operator or disrupt work.
- Three-ring pistons made of lightweight, silicon/aluminum alloy for strength and maximum thermal conductivity.
- Forged chrome/molybdenum-steel crankshaft with salt bath nitrocarburized pins and journals.
- Front and rear crankshaft oil seals are “lip” type Viton and PTFE designs featuring an integral dust lip.
- For durability, inlet valves are nitrided, martensitic chrome silicon steel, while exhaust valves are nitrided, austenitic chrome manganese-nickel steel.
- Cylinder block is high strength, cast iron alloy of deep skirt, monobloc design for increased strength and long life.
- Cylinder head is high strength, cast iron alloy construction with extra duty wall and deck thickness. Intake and exhaust ports are precision cast to promote optimum gas flow.
- Direct injection fuel system provides accurate fuel delivery and efficiency.
- Dry-type axial seal air cleaner with integral precleaner, automatic dust ejection system, and filter condition indicator.
- Direct electric, 12-volt starting and charging system with 880 CCA Group 31 maintenance free battery.
- Standard glow plug starting aid system for efficient cold weather starting.
- High contact ratio/gear train, peripheral fixed isolation top cover and open deck block design reduce bare engine noise.
- Higher low end torque for better engine/machine performance.
- Engine is equipped with electric fuel priming pump.

Brakes

Features:

- Brakes meet the following standards: SAE J1473 and ISO 3450 requirements.
- Self-adjusting, completely enclosed and sealed.
- Foot operated brake pedals can be interlocked for roading.
- Parking/secondary brakes are independent of the service brake system. Parking brake is mechanically applied through an adjustable hand lever located on the right console.

Machine Dimensions

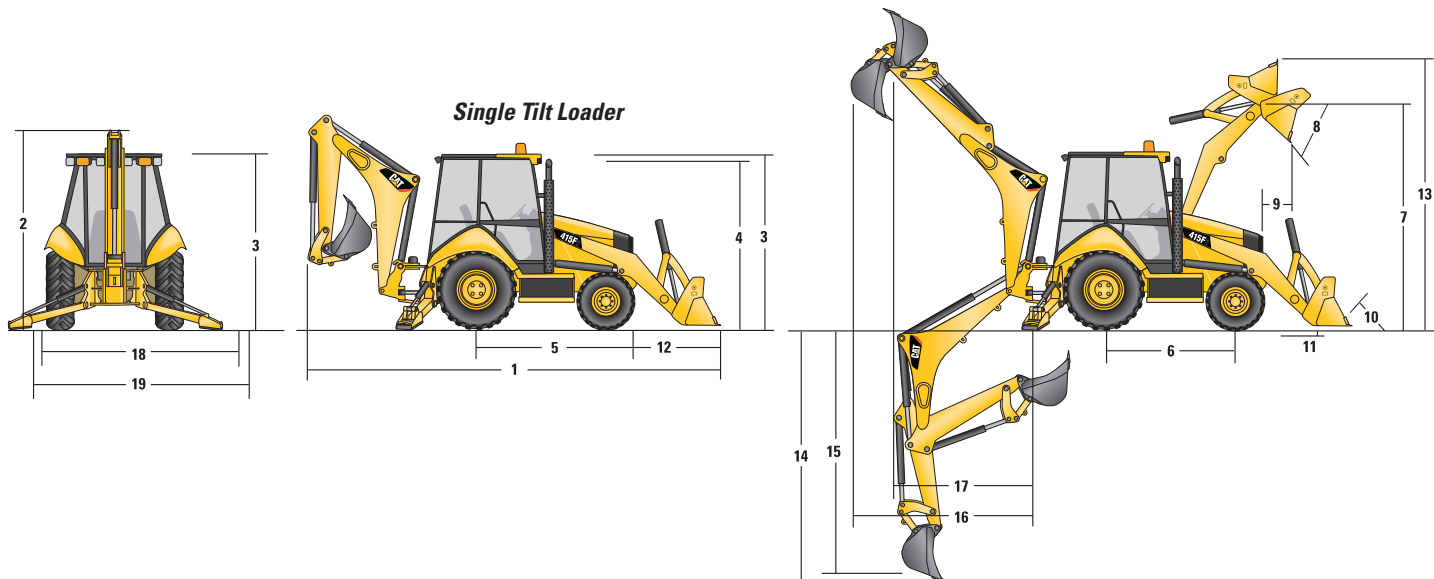

Single Tilt Loader

	General Purpose (0.76 m ³ /1.00 yd ³)	General Purpose (0.96 m ³ /1.25 yd ³)	Multi Purpose (1.00 m ³ /1.31 yd ³)	Multi Purpose with Forks (1.00 m ³ /1.31 yd ³)
1 Overall Length (Loader on Ground) – Standard Stick	7027 mm 23'1"	7140 mm 23'5"	7057 mm 23'2"	7057 mm 23'2"
Overall Length (Loader on Ground) – Extendible Stick	7033 mm 23'1"	7145 mm 23'5"	7063 mm 23'2"	7063 mm 23'2"
Overall Transport Length – Standard Stick	7085 mm 23'3"	7168 mm 23'6"	7132 mm 23'5"	7132 mm 23'5"
Overall Transport Length – Extendible Stick	7091 mm 23'3"	7174 mm 23'6"	7137 mm 23'5"	7137 mm 23'5"
2 Overall Transport Height – Standard Stick	3577 mm 11'9"	3577 mm 11'9"	3577 mm 11'9"	3577 mm 11'9"
Overall Transport Height – Extendible Stick	3631 mm 11'11"	3631 mm 11'11"	3631 mm 11'11"	3631 mm 11'11"
Overall Width	2322 mm 7'7"	2322 mm 7'7"	2322 mm 7'7"	2322 mm 7'7"
3 Height to Top of Cab/Canopy	2819 mm 9'3"	2819 mm 9'3"	2819 mm 9'3"	2819 mm 9'3"
4 Height to Top of Exhaust Stack	2744 mm 9'0"	2744 mm 9'0"	2744 mm 9'0"	2744 mm 9'0"
Height to Loader Hinge Pin (transport)	381 mm 1'3"	381 mm 1'3"	432 mm 1'5"	432 mm 1'5"
Ground Clearance (minimum)	294 mm 1'0"	294 mm 1'0"	294 mm 1'0"	294 mm 1'0"
5 Rear Axle Centerline to Front Grill	2705 mm 8'10"	2705 mm 8'10"	2705 mm 8'10"	2705 mm 8'10"
Front Wheel Tread Gauge	1895 mm 6'3"	1895 mm 6'3"	1895 mm 6'3"	1895 mm 6'3"
Rear Wheel Tread Gauge	1714 mm 5'7"	1714 mm 5'7"	1714 mm 5'7"	1714 mm 5'7"
6 Wheelbase 2WD/AWD	2200 mm 7'3"	2200 mm 7'3"	2200 mm 7'3"	2200 mm 7'3"

Dimensions and performance specifications shown are for machines equipped with 12.5/80-18 SGL front tires, 19.5L-24 IT525 rear tires, ROPS canopy, standard stick with 610 mm (24 in) standard duty bucket, 0.76 m³ (1.00 yd³) loader bucket and standard equipment unless otherwise specified.

415F2 Specifications

Loader Bucket Dimensions and Performance

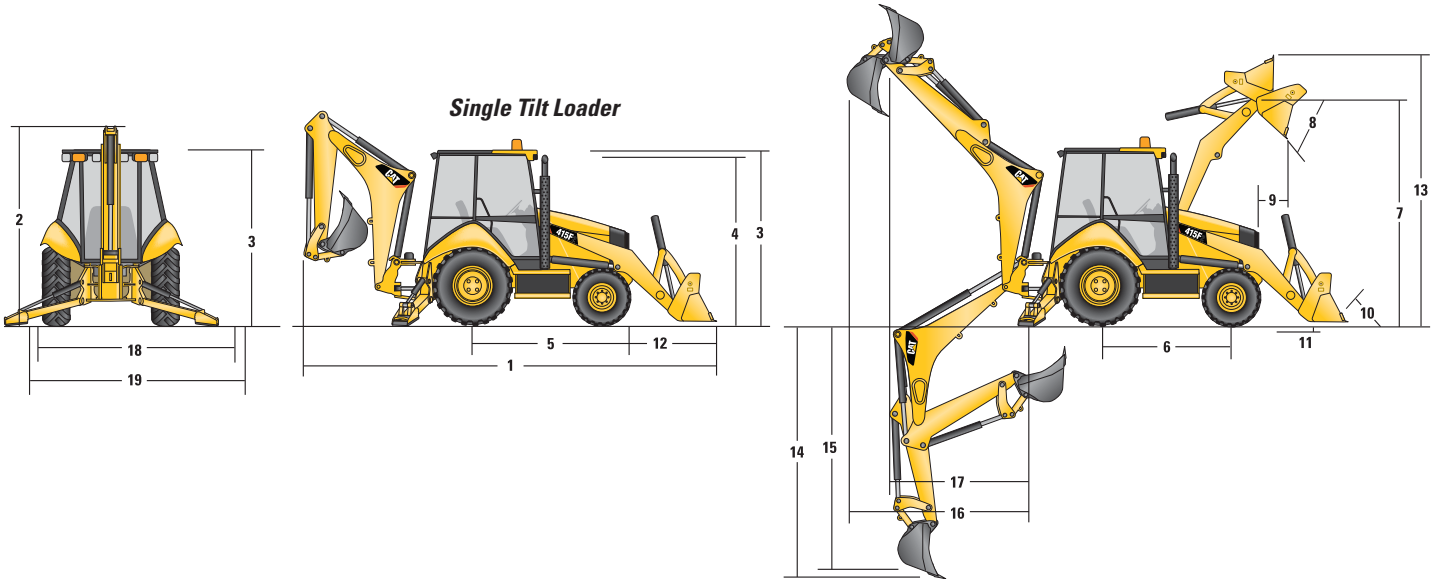

Single Tilt Loader

	General Purpose (0.76 m ³ /1.00 yd ³)		General Purpose (0.96 m ³ /1.25 yd ³)		Multi Purpose (1.00 m ³ /1.31 yd ³)		Multi Purpose with Forks (1.00 m ³ /1.31 yd ³)	
Capacity (SAE rated)	0.76 m ³	1.00 yd ³	0.96 m ³	1.25 yd ³	1.00 m ³	1.31 yd ³	1.00 m ³	1.31 yd ³
Overall Bucket Width	2262 mm	89"	2262 mm	89"	2279 mm	90"	2279 mm	90"
Lift Capacity at Maximum Height	3062 kg	6,751 lb	2964 kg	6,535 lb	2771 kg	6,108 lb	2656 kg	5,855 lb
Lift Breakout Force	47 919 N	10,772 lbf	45 326 N	10,189 lbf	44 392 N	9,979 lbf	42 904 N	9,645 lbf
Tilt Breakout Force	54 629 N	12,281 lbf	45 993 N	10,339 lbf	52 674 N	11,841 lbf	51 760 N	11,636 lbf
Tipping Load at Breakout Point	6831 kg	15,059 lb	6358 kg	14,016 lb	6428 kg	14,172 lb	6286 kg	13,858 lb
7 Maximum Hinge Pin Height	3474 mm	11'5"	3474 mm	11'5"	3474 mm	11'5"	3474 mm	11'5"
8 Dump Angle at Full Height	44°		44°		44°		44°	
Dump Height at Maximum Angle	2824 mm	9'3"	2746 mm	9'0"	2798 mm	9'2"	2798 mm	9'2"
9 Dump Reach at Maximum Angle	727 mm	2'5"	808 mm	2'8"	716 mm	2'4"	716 mm	2'4"
10 Maximum Bucket Rollback at Ground Level	37°		37°		38°		38°	
11 Digging Depth	83 mm	3"	83 mm	3"	110 mm	4"	110 mm	4"
Maximum Grading Angle	116°		112°		116°		116°	
Width of Dozer Cutting Edge	N/A		N/A		2262 mm	7'5"	2262 mm	7'5"
12 Grill to Bucket Cutting Edge, Carry Position	1404 mm	4'7"	1487 mm	4'11"	1451 mm	4'9"	1451 mm	4'9"
13 Maximum Operating Height	4206 mm	13'10"	4355 mm	14'3"	4404 mm	14'5"	4878 mm	16'0"
Jaw Opening Maximum	N/A		N/A		790 mm	2'7"	790 mm	2'7"
Bucket Jaw Clamping Force	N/A		N/A		50 600 N	11,375 lbf	50 600 N	11,375 lbf
Weight (does not include teeth or forks)	384 kg	847 lb	451 kg	994 lb	745 kg	1,642 lb	915 kg	2,017 lb

Dimensions and performance specifications shown are for machines equipped with 12.5/80-18 SGL front tires, 19.5L-24 IT525 rear tires, ROPS canopy, standard stick with 610 mm (24 in) standard duty bucket, 0.76 m³ (1.00 yd³) loader bucket and standard equipment unless otherwise specified.

Backhoe Dimensions and Performance

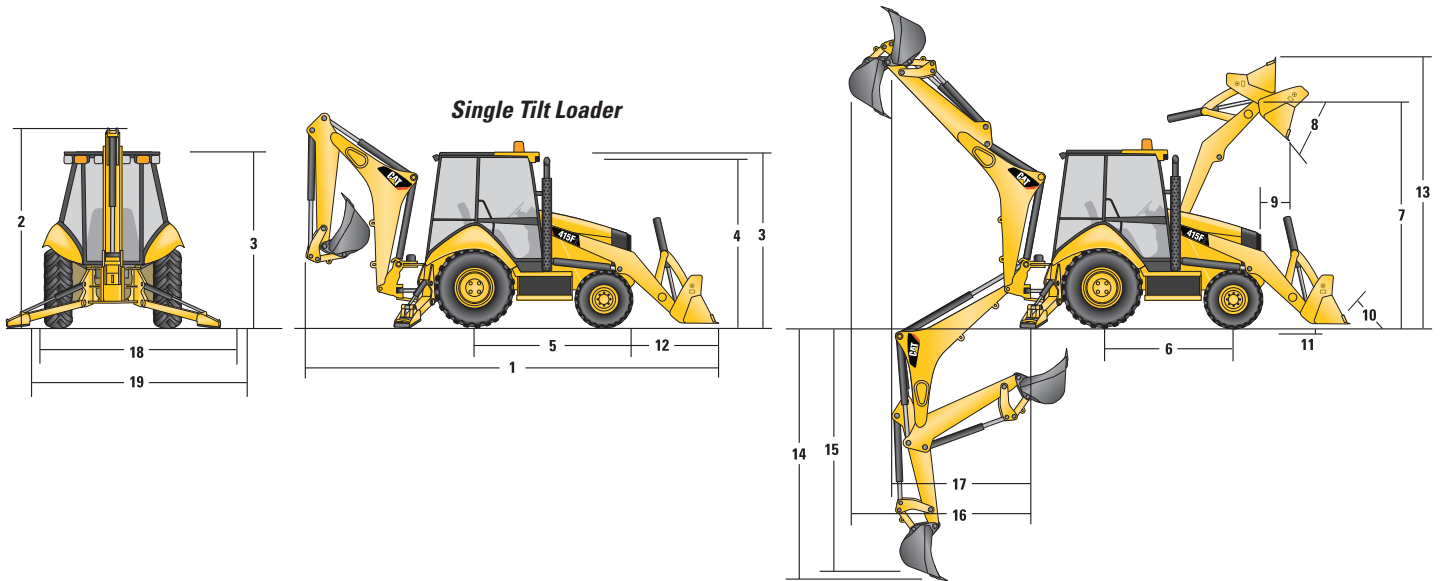

	Standard Stick		E-Stick Retracted		E-Stick Extended	
14 Digging Depth, SAE (maximum)	4348 mm	14'3"	4389 mm	14'5"	5441 mm	17'11"
15 Digging Depth, 610 mm (2 ft) Flat Bottom	4309 mm	14'2"	4350 mm	14'4"	5404 mm	17'10"
Reach from Rear Axle Centerline at Ground Line	6702 mm	22'1"	6738 mm	22'2"	7742 mm	25'6"
16 Reach from Swing Pivot at Ground Line	5612 mm	18'5"	5648 mm	18'7"	6652 mm	21'10"
Maximum Operating Height	5525 mm	18'2"	5549 mm	18'3"	6286 mm	20'8"
Loading Height	3643 mm	11'11"	3600 mm	11'9"	4170 mm	13'7"
17 Loading Reach	1838 mm	6'0"	1925 mm	6'4"	2840 mm	9'4"
Swing Arc	180°		180°		180°	
Bucket Rotation	205°		205°		205°	
18 Stabilizer Spread, Operating Position (center)	3310 mm	10'10"	3310 mm	10'10"	3310 mm	10'10"
Stabilizer Spread, Operating Position (outside)	3770 mm	12'4"	3770 mm	12'4"	3770 mm	12'4"
Stabilizer Spread, Transport Position	2322 mm	7'7"	2322 mm	7'7"	2322 mm	7'7"
Bucket Dig Force	59 118 N	13,290 lbf	58 287 N	13,103 lbf	58 287 N	13,103 lbf
Stick Dig Force	32 378 N	7,279 lbf	32 421 N	7,289 lbf	23 796 N	5,350 lbf

Dimensions and performance specifications shown are for machines equipped with 12.5/80-18 SGL front tires, 19.5L-24 IT525 rear tires, ROPS canopy, standard stick with 610 mm (24 in) standard duty bucket, 0.76 m³ (1.00 yd³) loader bucket and standard equipment unless otherwise specified.

415F2 Specifications

Backhoe Lift Capacity

Cat 415F2 Standard Stick

Boom Lifting	kg	lb
1	1296	2,851
2	1410	3,101
3	1419	3,123
4	1379	3,033
5	1326	2,917
6	1271	2,797
7	1218	2,680
8	1168	2,569
9	1121	2,466
10	1078	2,372
11	1039	2,286
12	1006	2,213
13	981	2,157
14	979	2,153
15	1073	2,361
Stick Lifting	kg	lb
16	1312	2,885
17	1849	4,068
18	2307	5,075
19	2400	5,280
20	2790	6,137
21	5561	12,234

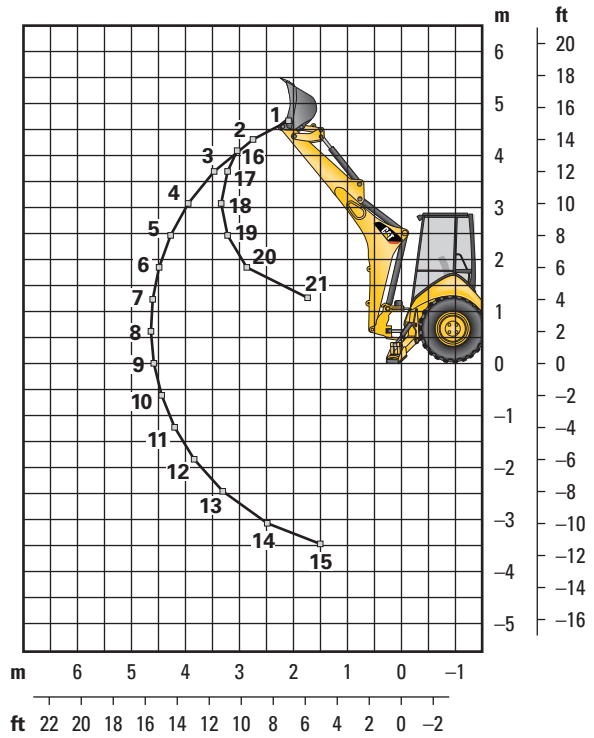

Cat 415F2 Extendible Stick – Retracted

Boom Lifting	kg	lb
1	1117	2,457
2	1214	2,670
3	1212	2,665
4	1166	2,566
5	1111	2,444
6	1054	2,319
7	999	2,197
8	946	2,082
9	897	1,974
10	852	1,873
11	809	1,780
12	771	1,696
13	738	1,623
14	718	1,580
15	767	1,687
Stick Lifting	kg	lb
16	1169	2,572
17	1694	3,726
18	2107	4,634
19	2183	4,802
20	2533	5,573
21	4983	10,963
22	5330	11,725

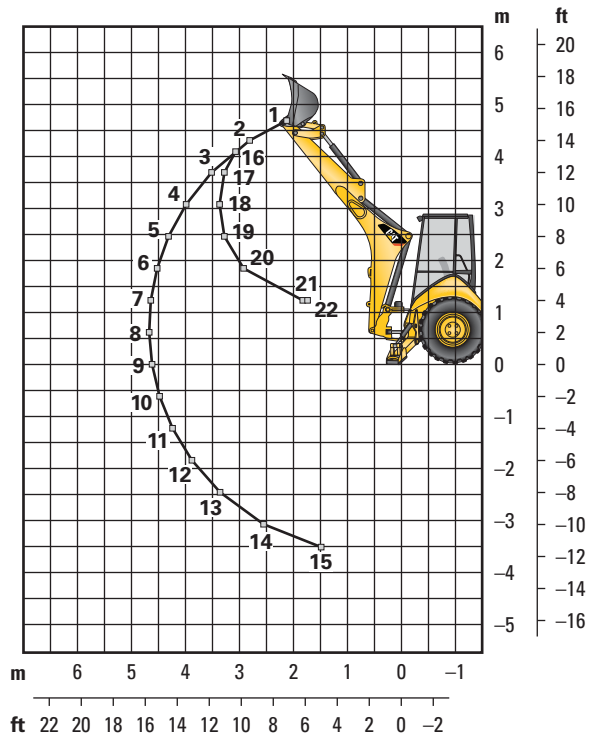

Lift Capacities are over-end values. Machine equipped with 4WD, OROPS, 0.76 m³ (1.00 yd³) general purpose bucket and no counterweight. Extendible stick includes 460 kg (1,015 lb) counterweight.

Backhoe Lift Capacity

Cat 415F2 Extendible Stick – Extended

Boom Lifting	kg	lb
1	617	1,357
2	750	1,650
3	797	1,752
4	802	1,765
5	791	1,741
6	770	1,695
7	750	1,649
8	726	1,597
9	702	1,544
10	679	1,493
11	657	1,445
12	637	1,401
13	620	1,363
14	607	1,334
15	601	1,322
16	612	1,347
17	699	1,537
18	1030	2,267
Stick Lifting	kg	lb
19	552	1,214
20	735	1,617
21	987	2,171
22	1162	2,556
23	1307	2,876
24	1460	3,212
25	1679	3,694
26	2192	4,823
27	5301	11,662

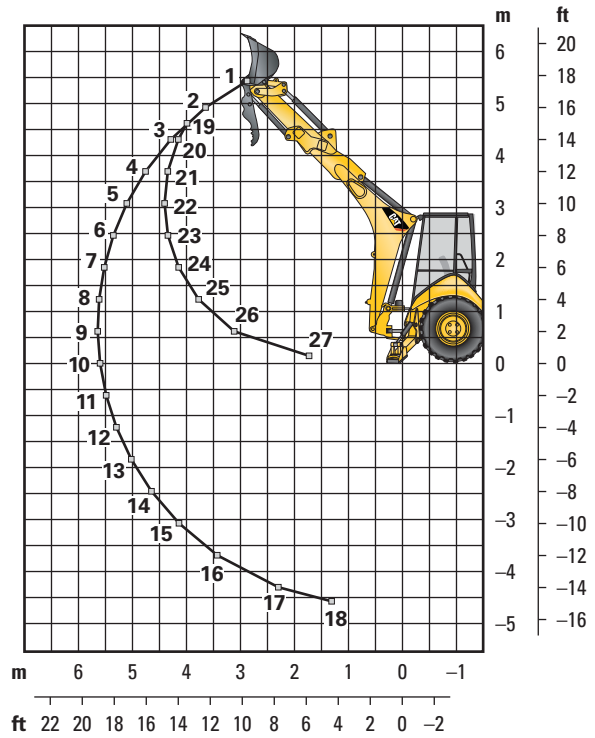

Lift Capacities are over-end values. Machine equipped with 4WD, OROPS, 0.76 m³ (1.00 yd³) general purpose bucket and no counterweight. Extendible stick includes 460 kg (1,015 lb) counterweight.

415F2 Specifications

Counterweights

Minimum Counterweight Recommendations

Standard Stick			
Loader Bucket	Power Train	kg	lb
GP	2WD	240	530
GP	4WD	115	255
MP	2WD/4WD	no counterweight	

Extendible Stick			
Loader Bucket	Power Train	kg	lb
GP	2WD/4WD	460	1,015
MP	2WD	240	530
MP	4WD	115	255

Backhoe Buckets

With weld on adapters and pin-on teeth

Standard Duty						
Width		Rated Capacity		Weight		No. of Teeth
mm	in	L	ft ³	kg	lb	
305	12	80	2.8	111	245	3
457	18	120	4.2	122	268	4
610	24	180	6.2	141	291	5
762	30	230	8.1	157	345	5
914	36	290	10.2	176	388	6

Heavy Duty						
Width		Rated Capacity		Weight		No. of Teeth
mm	in	L	ft ³	kg	lb	
305	12	80	2.8	121	266	3
406	16	110	3.9	128	282	3
457	18	120	4.2	135	299	4
610	24	180	6.2	151	333	5
762	30	230	8.1	177	391	5
914	36	290	10.2	201	443	6

Soil Excavation						
Width		Rated Capacity		Weight		No. of Teeth
mm	in	L	ft ³	kg	lb	
457	18	180	6.4	155	341	4
610	24	240	8.5	182	402	5
762	30	320	11.3	206	454	5
914	36	380	13.4	233	513	6

Heavy Duty Rock						
Width		Rated Capacity		Weight		No. of Teeth
mm	in	L	ft ³	kg	lb	
305	12	70	2.5	127	279	3
457	18	130	4.6	146	322	4
610	24	200	7.0	174	381	5
762	30	270	9.5	197	434	5
914	36	330	11.7	224	493	6

Coral						
Width		Rated Capacity		Weight		No. of Teeth
mm	in	L	ft ³	kg	lb	
305	12	60	2.1	134	295	4
457	18	100	3.5	155	341	6
610	24	140	4.9	182	402	8
762	30	190	6.7	210	463	10

Heavy Duty – Pin Lock						
Width		Rated Capacity		Weight		No. of Teeth
mm	in	L	ft ³	kg	lb	
305	12	96	3.4	113	249	3
406	16	123	4.3	131	288	3
457	18	139	4.9	139	307	4
610	24	207	7.3	168	370	5
762	30	275	9.7	194	428	5
914	36	345	12.2	224	494	6

High Capacity – Pin Lock						
Width		Rated Capacity		Weight		No. of Teeth
mm	in	L	ft ³	kg	lb	
305	12	96	4.6	113	287	3
406	16	123	5.6	131	327	3
457	18	139	6.5	139	346	4
610	24	207	9.6	168	414	5
762	30	275	12.9	194	475	5
914	36	345	16.2	224	543	6

Standard Equipment

Standard equipment may vary. Consult your Cat dealer for details.

- Air cleaner
- Alarm, back-up
- Alternator, 150 amp
- Audible system fault alarm
- Backhoe controls, mechanical two lever
- Battery, maintenance-free, 880 CCA
- Battery disconnect switch
- Battery remote jumpstart
- Boom transport lock
- Brace, lift cylinder
- Brake, secondary parking
- Brakes, hydraulically boosted, oil disc, dual pedals, interlocking
- Bucket level indicator
- Canopy, ROPS/FOPS
- Coat restraint
- Coolant/antifreeze, extended life
- Counterweight, bumper
- Dome light (cab only)
- Diagnostic port for engine
- Differential lock, loader joystick
- Drink holders, two
- Engine, Cat C3.4B, meets U.S. EPA Tier 4 Final emission standards, diesel particulate filter
- Engine enclosure, sound suppression removal panels
- Face seals, O-ring
- Fan, suction and guard
- Fast reversing shuttle, all gears
- Fenders, rear
- Filters, spin-on: fuel, engine oil, transmission oil, water separator
- Filters, bowl and cartridge: hydraulic fluid
- Flashing hazards/signal lights
- Floor mat
- Fuel tank, fully enclosed
- Fully hinged front grill for cooling package cleaning access
- Gauge cluster: coolant temperature, fuel level, torque converter temperature, battery voltage
- Ground level fuel fill
- High ambient cooling package
- Hood lock, inside cab
- Hydraulic hose, XT™
- Hydraulic oil cooler
- Hydraulic oil level sight gauge
- Hydraulic valve, hydrostatic steering
- Hydraulic valves, loader 2 function
- Hydraulic valves, backhoe 4 function
- Hydraulics, load sensing with variable displacement piston pump
- Indicator lights: wait to start, water in fuel, engine warning, warning lamp, object handling stability warning, manual regeneration required, low engine oil pressure; LCD warnings: machine locked (if equipped), service due, air filter blocked, auto idle shutdown, high coolant temperature, high torque converter temperature, high exhaust temperature, engine oil life indicator
- Instrument panel lights
- Key start/stop system
- LCD screen: engine speed, hour meter, gear/direction, battery voltage, hydraulic oil temperature, torque converter temperature, coolant temperature, trip totals (fuel and hours), lifetime totals (fuel and hours), operator settings (units, brightness, programmable hoe auxiliary flow), service mode diagnostics, oil life reset, DPF force regeneration, maintenance intervals, ECM/system info
- Lights, working (2 front, 2 rear)
- Loader, self-leveling, return-to-dig and transmission disconnect switch
- Loader, single tilt
- Mirror, rearview
- Open circuit breather
- Power receptacle, 12 volt, 2 internal, 1 external
- Power steering, hydrostatic
- Seat belt, retractable, 51 mm (2 in)
- Stabilizer shoes, street
- Steering knob
- Seat, air suspension, fabric or vinyl cover, with armrest
- Socket, two roof
- Starting system, glow plugs
- Steering, hydrostatic
- Storage compartment, lockable
- Storage tray
- Stop and tail lights
- Swing transport lock
- Tires
- Toolbox, external, lockable
- Torque converter
- Throttle, hand and foot, electronic
- Transmission, four speed, syncromesh
- Transmission neutralizer switch
- Transport tie-downs
- Two Wheel Drive
- Vandalism locks, three
- Warning horn, electric

415F2 Optional Equipment

Optional Equipment

Optional equipment may vary. Consult your Cat dealer for details.

- Backhoe controls, pilot joysticks
- Battery, additional, 880 CCA
- Cab, standard
- Cold weather fuel (-30° C/-22° F)
- Cold weather package, including additional battery, engine block heater, radiator antifreeze (-50° C/-58° F), cold weather fuel (-30° C/-22° F) and mounting for an ether bottle
- Counterweights, 115 kg (255 lb), 240 kg (530 lb) or 460 kg (1,015 lb)
- Fenders, front with integral steps
- Four Wheel Drive/Brake Mode Selector
- Guard, boom protection plate
- Guard, stabilizer, rock
- Hydraulic valves, loader (3rd valve for GP, MP or Quick Coupler)
- Hydraulic valves, backhoe (5th and 6th function)
- Hydraulic lines, combined function auxiliary
- Product Link, satellite, PL631E
- Product Link, cellular, PL641I
- Quick Coupler, hydraulic, dual lock
- Quick Coupler, manual, dual lock
- Quick Coupler, pin lock
- Radio and CD player
- Radio and CD player, Bluetooth
- Ride Control
- Rotating beacon, magnetic mount
- Seat belt, 75 mm (3 in)
- Security system keypad
- Stabilizer pads, grouser type
- Stabilizer pads, reversible
- Stick, extendible
- Storage box
- Vandalism protection, gauge cover
- Work Tool Attachments such as buckets, forks, material handling arms, augers, hammers, brooms, cold planers and vibratory plate compactors. See your Cat dealer for more information.

For more complete information on Cat products, dealer services, and industry solutions, visit us on the web at www.cat.com

AEHQ7457 (06-2015)
(NACD)

© 2015 Caterpillar
All rights reserved

Materials and specifications are subject to change without notice. Featured machines in photos may include additional equipment. See your Cat dealer for available options.

CAT, CATERPILLAR, SAFETY.CAT.COM, their respective logos, "Caterpillar Yellow" and the "Power Edge" trade dress, as well as corporate and product identity used herein, are trademarks of Caterpillar and may not be used without permission.

