

400 Series 403A-11G1 ElectropaK

9 kVA / 7.2 kWe prime power @ 1500 rpm

9.9 kVA / 7.9 kWe standby power @ 1500 rpm

The Perkins® 400 Series engine family continues to set new standards in the compact engine market. Developed alongside customers to fulfill their needs in the generator set, compressor, agricultural and general industrial markets.

These new ElectropaKs provide compact power, from a robust family of 3 and 4 cylinder diesel engines designed to provide economic and durable operation at Prime and Standby duties, hitting the key power nodes required by the power generation industry.



Specification		
Number of cylinders	3 vertical in-line	
Bore and stroke	77 x 81 mm	3.0 x 3.2 in
Displacement	1.131 litres	69 in ³
Aspiration	Naturally aspirated	
Cycle	4 stroke	
Combustion system	Indirect injection	
Compression ratio	23:1	
Rotation	Anti-clockwise, viewed on flywheel	
Total lubricating capacity	4.9 litres	1.29 US gal
Cooling system	Water cooled	
Total coolant capacity	5.2 litres	1.37 US gal

www.perkins.com

Photographs are for illustrative purposes only and may not reflect final specification.
All information in this document is substantially correct at time of printing and may be altered subsequently.
Final weight and dimensions will depend on completed specification.

Publication No. PN2004/12/14 Produced in England ©2014 Perkins Engines Company Limited

 **Perkins®**

THE HEART OF EVERY GREAT MACHINE

400 Series 403A-11G1 ElectropaK

9 kVA / 7.2 kWe prime power @ 1500 rpm

9.9 kVA / 7.9 kWe standby power @ 1500 rpm

Features and benefits

Powered by your needs

- The 403A-11G1 ElectropaK is a powerful but quiet 1.1 litre naturally aspirated 3-cylinder compact package

Compact, clean, efficient power

- Design features on the 400 Series ElectropaKs ensure clean rapid starting in all conditions whilst delivering impressive performance, with low operating costs, in a small, efficient package size

Lower operating costs

- Approved for operation on biodiesel* concentrations of up to 20%
- Oil and filter changes are 500 hours, dependent on load factor
- Engine durability and reliability, the warranty offering and ease of installation combine to drive down the cost of ownership

Warranties and Service Contracts

We provide one-year warranties for constant speed engines and two-year warranties for variable speed models, as standard. These are supported by multilevel Extended Service Contracts that can be bought additionally

Discover more: www.perkins.esc

Product support

- With highly trained Perkins distributors in thousands of communities in over 180 countries, you are never far away from expert product knowledge, genuine parts and a range of advanced diagnostic technology for keeping your engine in peak condition
- To find your local distributor: www.perkins.com/distributor

*Subject to conformance with ASTM D6751 and EN14214

www.perkins.com

Photographs are for illustrative purposes only and may not reflect final specification.
All information in this document is substantially correct at time of printing and may be altered subsequently.
Final weight and dimensions will depend on completed specification.

Publication No. PN2004/12/14 Produced in England ©2014 Perkins Engines Company Limited

 **Perkins**[®]

THE HEART OF EVERY GREAT MACHINE

400 Series 403A-11G1 ElectropaK

9 kVA / 7.2 kWe prime power @ 1500 rpm

9.9 kVA / 7.9 kWe standby power @ 1500 rpm

Technical information

Air inlet

- Mounted air filter

Fuel system

- Mechanically governed cassette type fuel injection pump
- Split element fuel filter

Lubrication system

- Wet steel sump with filler and dipstick
- Spin-on full-flow lub oil filter

Cooling system

- Thermostatically-controlled system with belt driven coolant pump and pusher fan
- Mounted radiator, piping and guards

Electrical equipment

- 12 volt starter motor and 12 volt 15 amp alternator with DC output
- Oil pressure and coolant temperature switches
- 12 volt shut-off solenoid energised to run
- Glow plug cold start aid and heater/starter switch

Flywheel and housing

- 1500 rev/min
- High inertia flywheel to SAE J620 Size 165.1 mm (6½ in) Heavy
- Flywheel housing SAE 5 Long

Mountings

- Front and rear engine mounting brackets

Optional equipment

- Parts book

Option groups

A selection of optional items is available to enable you to prepare a specification precisely matched to your needs.

www.perkins.com

Photographs are for illustrative purposes only and may not reflect final specification.
All information in this document is substantially correct at time of printing and may be altered subsequently.
Final weight and dimensions will depend on completed specification.

Publication No. PN2004/12/14 Produced in England ©2014 Perkins Engines Company Limited

 **Perkins**[®]

THE HEART OF EVERY GREAT MACHINE

400 Series 403A-11G1 Electropak

9 kVA / 7.2 kWe prime power @ 1500 rpm

9.9 kVA / 7.9 kWe standby power @ 1500 rpm

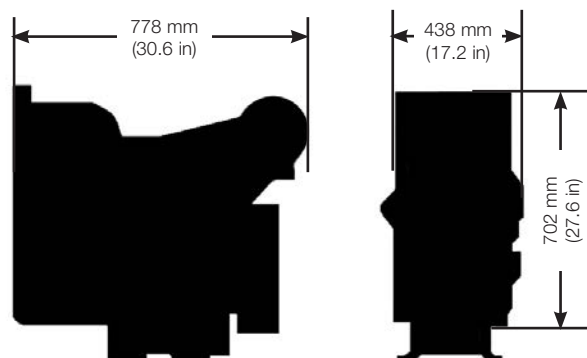

Engine package weights and dimensions

Engine package weights and dimensions		
Length	778 mm	30.6 in
Width (including mounting brackets)	438 mm	17.2 in
Height	702 mm	27.6 in
Weight (dry)	197 kg	434.4 lb

www.perkins.com

Photographs are for illustrative purposes only and may not reflect final specification.
All information in this document is substantially correct at time of printing and may be altered subsequently.
Final weight and dimensions will depend on completed specification.

Publication No. PN2004/12/14 Produced in England ©2014 Perkins Engines Company Limited

 **Perkins**[®]

THE HEART OF EVERY GREAT MACHINE

400 Series 403A-11G1 ElectropaK

9 kVA / 7.2 kWe prime power @ 1500 rpm

9.9 kVA / 7.9 kWe standby power @ 1500 rpm

Speed rpm	Type of operation	Typical generator output (Net)		Engine power			
				Gross		Net	
		kVA	kWe	kWm	hp	kWm	hp
1500	Prime power	9.0	7.2	8.6	11.5	8.4	11.3
	Standby power	9.9	7.9	9.5	12.7	9.2	12.4

The above ratings represent the engine performance capabilities to conditions specified in ISO 8528/1, ISO 3046/1:1986, BS 5514/1. **Derating** may be required for conditions outside these; consult Perkins Engines Company Limited.

Generator powers are typical and are based on typical alternator efficiencies and a power factor (cos θ) of 0.8. **Fuel specification:** BS 2869: Part 2 1998 Class A2 or ASTM D975 D2.

Rating definitions: **Prime power:** Power available at variable load in lieu of a main power network. Overload of 10% is permitted for 1 hour in every 12 hours operation. **Standby (maximum):** Power available at variable load in the event of a main power network failure. No overload is permitted.

Percent of prime power	Fuel consumption at 1500 rpm g/kWh	Fuel consumption at 1500 rpm l/hr
Standby power	268	3.6
Prime power	248	3.0
75%	257	2.3
50%	280	1.7

www.perkins.com

Photographs are for illustrative purposes only and may not reflect final specification. All information in this document is substantially correct at time of printing and may be altered subsequently. Final weight and dimensions will depend on completed specification.

Publication No. PN2004/12/14 Produced in England ©2014 Perkins Engines Company Limited

 **Perkins**[®]

THE HEART OF EVERY GREAT MACHINE