

400 Series 402D-05G Electro Unit

5.1 kWm @ 1800 rpm

The Perkins® 400 Series engine family continues to set new standards in the compact engine market. Developed alongside customers to fulfill their needs in the gen set, compressor, agricultural and general industrial markets.

These new electro units provide compact power, from a robust family of 2, 3 and 4 cylinder diesel engines designed to provide economic and durable operation at prime and standby duties, hitting the key power nodes required by the power generation industry.



Emissions statement

Industrial and IOPU Engines: Certified against the requirements of EU Stage IIIA (Directives 97/68/EC as last amended, and 2004/26/EC, as last amended).

Constant Speed engines for use in Industrial, IOPU and ElectropaK applications: Certified against the requirements of EU Stage IIIA (Directive 97/68/EC, as last amended for mobile applications).

Specification		
Number of cylinders	2 in-line	
Bore and stroke	67 x 72 mm	2.6 x 2.8 in
Displacement	0.51 litres	31 in ³
Aspiration	Naturally aspirated	
Cycle	4 stroke	
Combustion system	Indirect injection	
Compression ratio	23.5:1	
Rotation	Anti-clockwise, viewed on flywheel	
Total lubricating capacity	2.01 litres	0.5 US gal
Cooling system	Liquid	
Total coolant capacity	1.1 litres	0.3 US gal

www.perkins.com

Photographs are for illustrative purposes only and may not reflect final specification.
All information in this document is substantially correct at time of printing and may be altered subsequently.
Final weight and dimensions will depend on completed specification.

Publication No. PN1954A/12/14 Produced in England ©2014 Perkins Engines Company Limited

 **Perkins®**

THE HEART OF EVERY GREAT MACHINE

400 Series 402D-05G Electro Unit

5.1 kWm @ 1800 rpm

Features and benefits

Powered by your needs

- The Perkins 400D range has been developed in consultation with our marketplace. This 0.5 litre, 2 cylinder engine is the smallest engine offered by Perkins. However, this ultra-compact, lightweight power unit still maintains all the customer benefits experienced from this exciting product range

Compact, clean, efficient power

- Design features on the 400D range of ElectropaKs and Electro Units ensure clean rapid starting in all conditions whilst delivering impressive performance with low operating costs in a small, efficient package size

Lower operating costs

- Approved for operation on biodiesel* concentrations of up to 20%
- Oil and filter changes are 500 hours, dependent on load factor
- Engine durability and reliability, the warranty offering and ease of installation combine to drive down the cost of ownership

Long-term power solution

- The 400D range of electropaKs and electro units have been designed to fully comply with stringent EU emissions regulations, providing an emissions compliant power solution for the future
- **Warranties and Service Contracts**
We provide one-year warranties for constant speed engines and two-year warranties for variable speed models, as standard. These are supported by multilevel Extended Service Contracts that can be bought additionally
Discover more: www.perkins.esc

Product support

- With highly trained Perkins distributors in thousands of communities in over 180 countries, you are never far away from expert product knowledge, genuine parts and a range of advanced diagnostic technology for keeping your engine in peak condition
- To find your local distributor: www.perkins.com/distributor

*Subject to conformance with ASTM D6751 and EN14214

www.perkins.com

Photographs are for illustrative purposes only and may not reflect final specification.
All information in this document is substantially correct at time of printing and may be altered subsequently.
Final weight and dimensions will depend on completed specification.

Publication No. PN1954A/12/14 Produced in England ©2014 Perkins Engines Company Limited

 **Perkins**[®]

THE HEART OF EVERY GREAT MACHINE

400 Series 402D-05G Electro Unit

5.1 kWm @ 1800 rpm

Technical information

Air inlet

- Mounted air filter

Fuel system

- Mechanically governed cassette type fuel injection pump
- Split element fuel filter

Lubrication system

- Wet steel sump with filler and dipstick
- Spin-on full-flow lub oil filter

Cooling system

- Thermostatically-controlled system with belt driven coolant pump and pusher fan

Electrical equipment

- 12 volt starter motor and 12 volt 14 amp alternator with DC output
- Oil pressure and coolant temperature switches
- 12 volt shut-off solenoid energised to run
- Glow plug cold start aid and heater/starter switch

Flywheel and housing

- High inertia flywheel to SAE J620 Size 6½ Heavy
- Flywheel housing SAE 5 Long

Cooling pack

- Radiator and hoses supplied separately

Optional equipment

- Parts book

Option groups

A selection of optional items is available to enable you to prepare a specification precisely matched to your needs.

www.perkins.com

Photographs are for illustrative purposes only and may not reflect final specification.
All information in this document is substantially correct at time of printing and may be altered subsequently.
Final weight and dimensions will depend on completed specification.

Publication No. PN1954A/12/14 Produced in England ©2014 Perkins Engines Company Limited

 **Perkins**[®]

THE HEART OF EVERY GREAT MACHINE

400 Series 402D-05G Electro Unit

5.1 kWm @ 1800 rpm

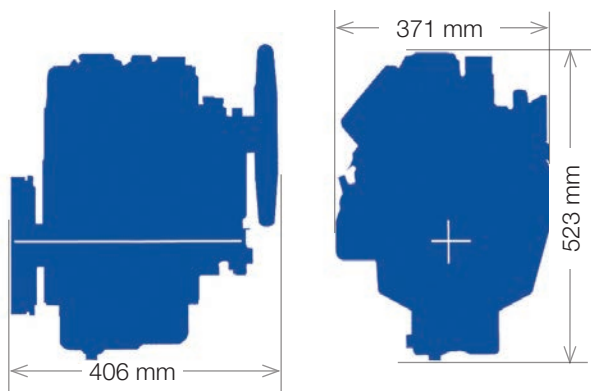

Engine package weights and dimensions		
Length	406 mm	16.0 in
Width	371 mm	14.6 in
Height	523 mm	20.6 in
Weight (dry)	57 kg	126 lb

www.perkins.com

Photographs are for illustrative purposes only and may not reflect final specification.
All information in this document is substantially correct at time of printing and may be altered subsequently.
Final weight and dimensions will depend on completed specification.

Publication No. PN1954A/12/14 Produced in England ©2014 Perkins Engines Company Limited

 **Perkins**[®]

THE HEART OF EVERY GREAT MACHINE

400 Series 402D-05G Electro Unit

5.1 kWm @ 1800 rpm

Speed rpm	Type of operation	Typical generator output (Net)		Engine power			
				Gross		Net	
		kVA	kWe	kWm	hp	kWm	hp
1800	Prime power	4.8	3.9	-	-	4.5	6.1
	Standby power	5.4	4.3	5.1	6.8	5.0	6.7

The above ratings represent the engine performance capabilities to conditions specified in ISO 8528/1, ISO 3046/1:1986, BS 5514/1.

Percent of prime power	Fuel consumption at 1800 rpm g/kWh	Fuel consumption at 1800 rpm l/hr
Prime power	275	2.7

www.perkins.com

Photographs are for illustrative purposes only and may not reflect final specification.
All information in this document is substantially correct at time of printing and may be altered subsequently.
Final weight and dimensions will depend on completed specification.

Publication No. PN1954A/12/14 Produced in England ©2014 Perkins Engines Company Limited

 **Perkins**[®]

THE HEART OF EVERY GREAT MACHINE