

1200 Series 1204F-E44TA Industrial Open Power Unit

EU Stage IV, EPA Tier 4 Final
74.5-110.1 kW / 100-147.6 hp

Building on its already strong EU Stage IV and EPA Tier 4 industrial range, Perkins is pleased to announce the introduction of the 1204F Industrial Open Power Unit (IOPU).

The Perkins four cylinder IOPU is an industry leader in flexibility. Offering a wide choice of options, the whole engine has been built around the demands of our customers and as such offers a great package with a simple integration design.

The 1204F-E44TA and 1204F-E44TTA IOPUs are turbocharged and series turbocharged respectively. They are air-to-air charge cooled, 4.4 litre, 4 cylinder units capable of producing 74.5-129.4 kW (100-173.5 hp). These engines provide excellent power density and fast response in a compact package – allowing customers to downsize from a six cylinder engine whilst maintaining power.

The IOPUs are designed to be productive and have a new range of power ratings to ensure the customer maximizes their profitability.

Perkins have developed a reputation for designing and building reliable and durable engines suitable for the most demanding applications.

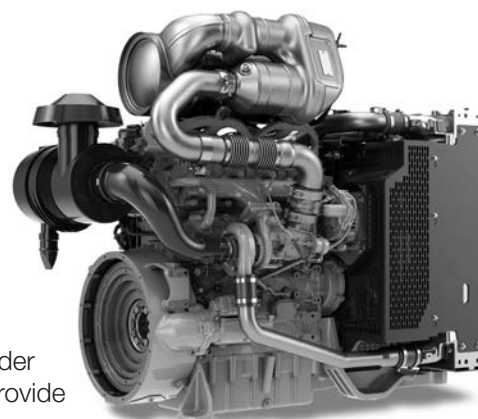

Emissions

Designed to meet EU Stage IV (Europe), EPA Tier 4 Final (US) and MLIT 2014 Regulations (Japan).

Specification		
Number of cylinders	4 in-line	
Bore and stroke	105 x 127 mm	4.13 x 5 in
Displacement	4.4 litres	268.5 in ³
Aspiration	Turbocharged aftercooled	
Cycle	4 stroke	
Combustion system	Direct injection	
Compression ratio	16.5:1	
Rotation	Anti-clockwise, viewed on flywheel	
Total lubricating capacity	5.2-13.5 litres	1.37-3.57 US gal
Cooling system	Liquid	
Total coolant capacity	10.8 litres	2.85 US gal

www.perkins.com

Photographs are for illustrative purposes only and may not reflect final specification.
All information in this document is substantially correct at time of printing and may be altered subsequently.
Final weight and dimensions will depend on completed specification.

Publication No. PN3066A/12/14 Produced in England ©2014 Perkins Engines Company Limited

 **Perkins**[®]

THE HEART OF EVERY GREAT MACHINE

1200 Series 1204F-E44TA Industrial Open Power Unit

EU Stage IV, EPA Tier 4 Final
74.5-110.1 kW / 100-147.6 hp

Features and benefits

Dependable power

- World-class manufacturing capability and processes coupled with proven core engine designs assure reliability, quiet operation, and many hours of productive life

Lifetime of low cost

- Fuel consumption optimized to match operating cycles of a wide range of equipment and applications
- Hydraulic tappets, multi-vee belts and 500 hour oil change intervals enable low-cost maintenance
- Extended Service Contracts – protect and plan the cost of ownership
Discover more: www.perkins.com/esc

Industry leading flexibility

- Exceptional power density enables standardisation across numerous applications. Multiple installation options minimise total package size. Ideal for equipment with narrow engine compartments

Local support, global coverage

- Perkins recognise that the customer relationship is important to machine manufacturers and we can offer a range of flexible solutions to help provide appropriate support, either to the OEM's network or directly to the machine customer
- Perkins information systems enable our distributors to quickly diagnose engine faults and identify the right parts. The Perkins logistics operation is able to dispatch more than 45,000 different parts from stock, reaching the customer within 24 hours
- To find your local distributor: www.perkins.com/distributor

www.perkins.com

Photographs are for illustrative purposes only and may not reflect final specification.
All information in this document is substantially correct at time of printing and may be altered subsequently.
Final weight and dimensions will depend on completed specification.

Publication No. PN3066A/12/14 Produced in England ©2014 Perkins Engines Company Limited

 **Perkins**[®]

THE HEART OF EVERY GREAT MACHINE

1200 Series 1204F-E44TA Industrial Open Power Unit

EU Stage IV, EPA Tier 4 Final
74.5-110.1 kW / 100-147.6 hp

Technical information

Air inlet

- Standard air cleaners

Control system

- Full electronic control system
- All connectors and wiring looms waterproof and designed to withstand harsh off-highway environments
- Flexible and configurable software features and J1939 standard communications I/O

Cooling system

- Engine mounted radiator with top tank temperature of 108°C
- 50:50 water glycol mix
- Detailed guidance on cooling system design and validation available to ensure machine reliability

Standard emissions control equipment

- NRS – NOx Reduction System

Flywheels and flywheel housing

- SAE3 configuration as standard

Fuel system

- Electronic high pressure common rail
- Standard and heavy duty fuel filtration

Oil system

- Choice of sumps for different applications

Power take-off

- SAE A or SAE B flanges on left-hand side, additional SAE A flange available on front of the engine on some applications

General

- Balancer option available
- Pusher or puller fan options

www.perkins.com

Photographs are for illustrative purposes only and may not reflect final specification.
All information in this document is substantially correct at time of printing and may be altered subsequently.
Final weight and dimensions will depend on completed specification.

Publication No. PN3066A/12/14 Produced in England ©2014 Perkins Engines Company Limited

 **Perkins**[®]

THE HEART OF EVERY GREAT MACHINE

1200 Series 1204F-E44TA Industrial Open Power Unit

EU Stage IV, EPA Tier 4 Final
74.5-110.1 kW / 100-147.6 hp

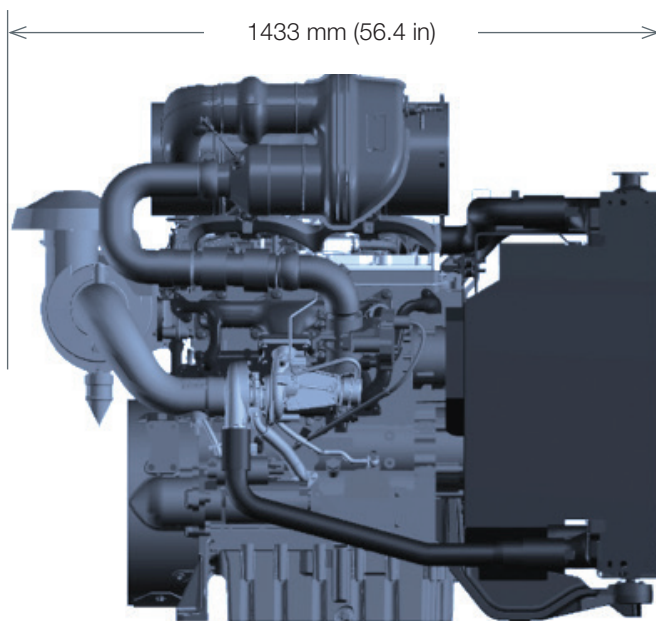
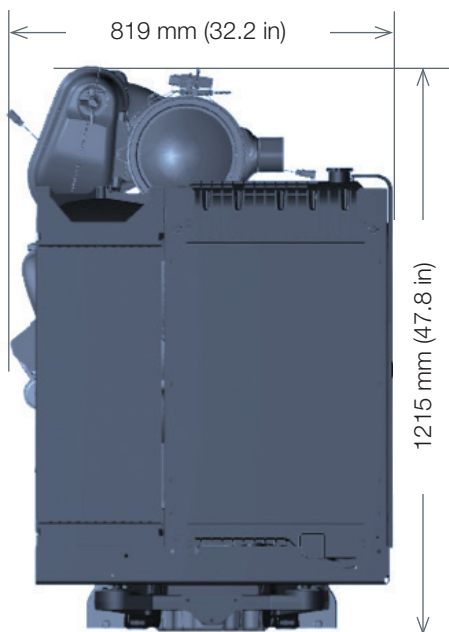

Engine package weights and dimensions

Engine package weights and dimensions		
Length	1433 mm	56.4 in
Width	819 mm	32.2 in
Height (including aftertreatment)	1215 mm	47.8 in
Weight (dry)	670 kg	1477 lb

www.perkins.com

Photographs are for illustrative purposes only and may not reflect final specification.
All information in this document is substantially correct at time of printing and may be altered subsequently.
Final weight and dimensions will depend on completed specification.

Publication No. PN3066A/12/14 Produced in England ©2014 Perkins Engines Company Limited

 **Perkins**[®]

THE HEART OF EVERY GREAT MACHINE

1200 Series 1204F-E44TA Industrial Open Power Unit

EU Stage IV, EPA Tier 4 Final
74.5-110.1 kW / 100-147.6 hp

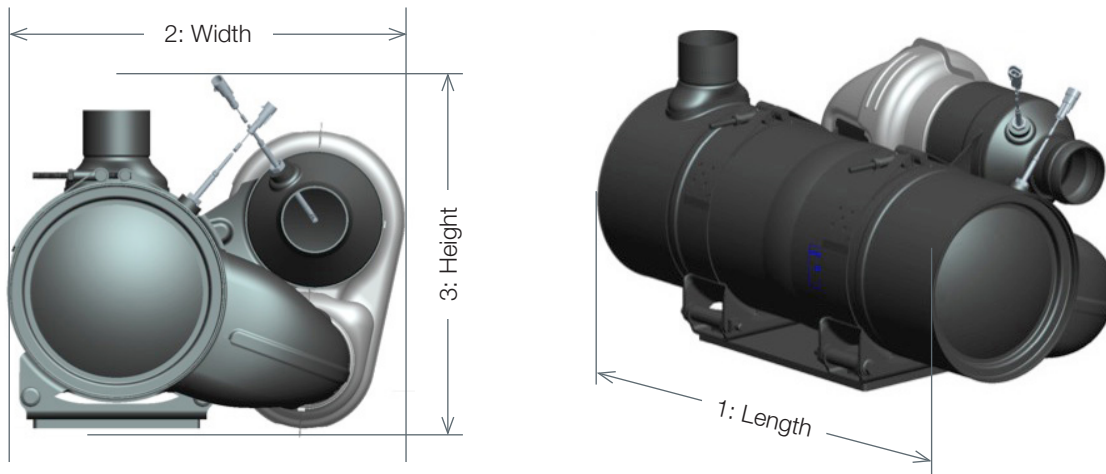

		Aftertreatment weights and dimensions			
		≤ 92.6 kW (124.2 bhp)		> 92.6 kW (124.2 bhp)	
1	Length	647 mm	25.4 in	675 mm	26.5 in
2	Width	453 mm	17.8 in	478 mm	18.8 in
3	Height	372 mm	14.6 in	390 mm	15.3 in
	Weight	40 kg	88 lb	45 kg	99 lb

Aftertreatment module factory fitted to engine as standard.

Aftertreatment

- DOC – Diesel Oxidation Catalyst
- SCR – Selective Catalytic Reduction
- 3 inch flex pipe kits available with a variety of elbow options for turbocharger connection
- SCR Auxiliaries – A range of tanks and heated lines are available

Technology

The DOC/SCR technology provides a compact aftertreatment solution, whilst still providing the performance our customers require.

Power

Using our advanced research and development techniques, we have perfectly matched the aftertreatment system to the engine. The engine performance has then been optimised to give the application maximum productivity whilst the aftertreatment remains invisible to the equipment operator when in use.

Mounting

Engine mounted installation simplifies customers integration and manufacturing requirements.

Service

Service free for the life of the engine.

www.perkins.com

Photographs are for illustrative purposes only and may not reflect final specification.
All information in this document is substantially correct at time of printing and may be altered subsequently.
Final weight and dimensions will depend on completed specification.

Publication No. PN3066A/12/14 Produced in England ©2014 Perkins Engines Company Limited

 **Perkins**[®]

THE HEART OF EVERY GREAT MACHINE

1200 Series 1204F-E44TA Industrial Open Power Unit

EU Stage IV, EPA Tier 4 Final
74.5-110.1 kW / 100-147.6 hp

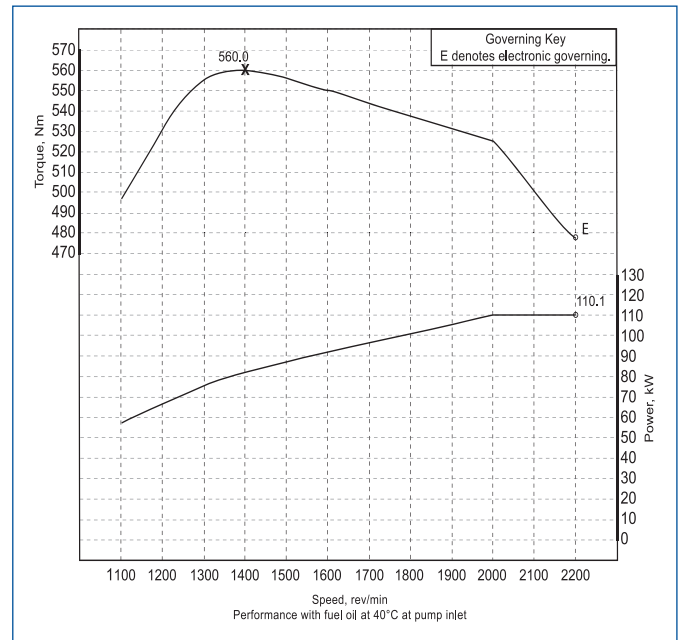
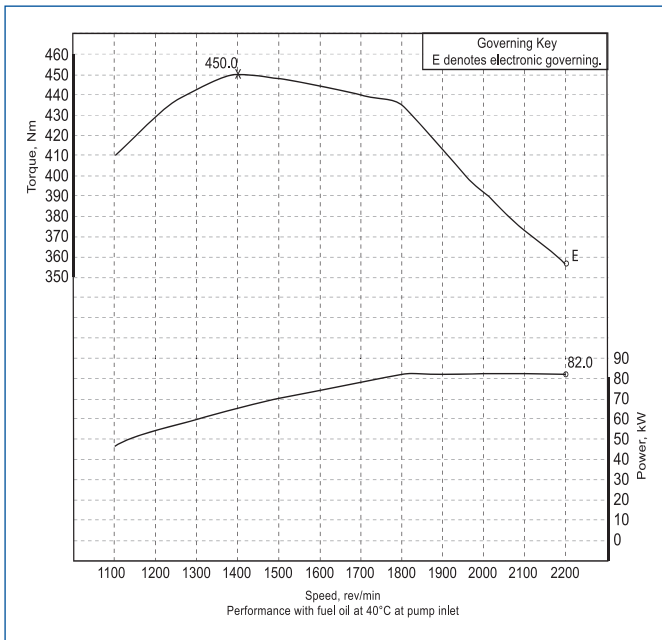

Speed rpm	Power kW	Power hp	Speed rpm	Torque Nm	Torque lb-ft	Rating type
2200	74.5	100.0	1400	450	332.0	C
2200	*82.0	110.0	1400	450	332.0	C
2200	92.5	124.0	1400	530	391.0	B
2200	102.1	137.0	1400	560	413.0	C
2200	*110.1	147.6	1400	560	413.0	C

* Curve shown

Rating Standard ISO 14396:2002

Unless otherwise specified, all stated data is for maximum rated speed and 100% load

Rating definitions and conditions

IND-B for service where power and/or speed are cyclic (time at full load not to exceed 80%).

IND-C (Intermittent) is the horsepower and speed capability of the engine where maximum power and/or speed are cyclic (time at full load not to exceed 50%).

Additional ratings are available for specific customer requirements. Consult your Perkins distributor.

Rating Conditions for Diesel Engines – up to 7.1 litres are based on ISO/TR14396, inlet air standard conditions with a total barometric pressure of 100 kPa (29.5 in. Hg), with a vapour pressure of 1 kPa (0.295 in Hg) and 25°C (77°F). Performance is measured using fuel to specification EPA 2D 89.330-96 with a density of 0.845-0.850 kg/L @ 15°C (59°F) and fuel inlet temperature 40°C (104°F).

www.perkins.com

Photographs are for illustrative purposes only and may not reflect final specification.
All information in this document is substantially correct at time of printing and may be altered subsequently.
Final weight and dimensions will depend on completed specification.

Publication No. PN3066A/12/14 Produced in England ©2014 Perkins Engines Company Limited

Perkins®

THE HEART OF EVERY GREAT MACHINE