

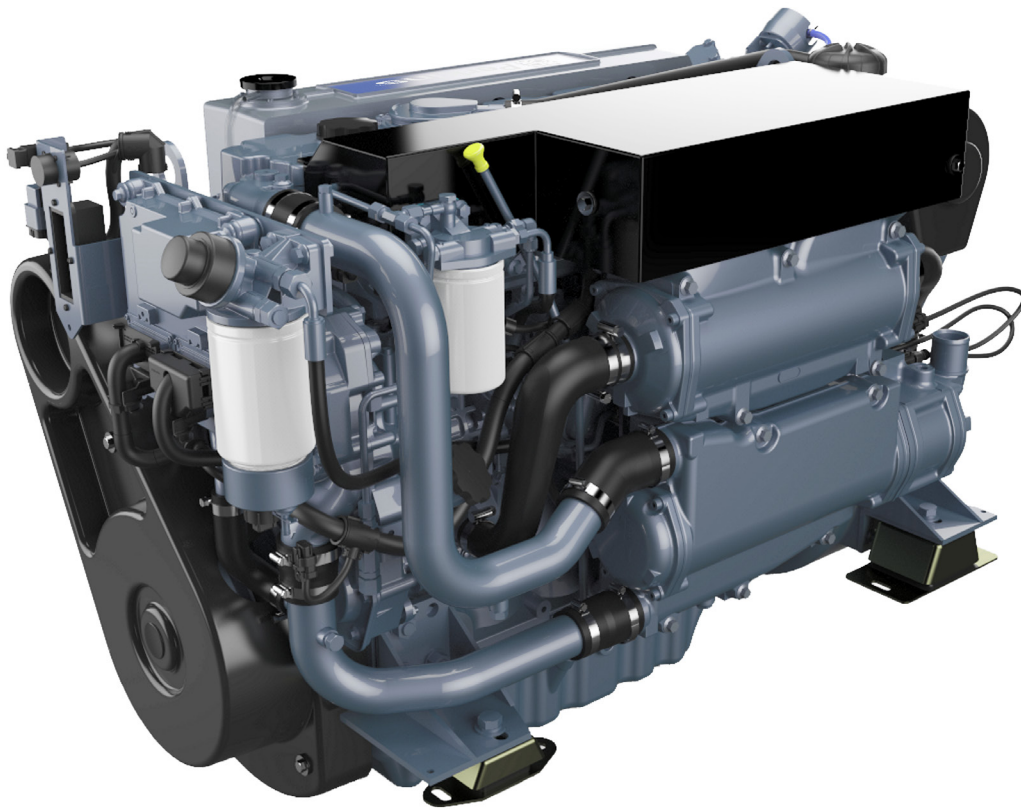

# Installation Manual



## 1106 Series Marine Propulsion Engines



# Perkins M300C, M250C, M216C & M190C Installation Manual

6 cylinder, turbocharged, intercooled, diesel engine for  
marine propulsion applications

Publication N40475, Issue 3

© Proprietary information of Wimborne Marine Power Centre, all rights reserved.

The information is correct at the time of print.

Published in December 2013 by Wimborne Marine Power Centre,

Wimborne Marine Power Centre, Wimborne, Dorset, England BH21 7PW

**Tel:**+44(0)1202 796000 **Fax:** +44(0)1202 796001 **E-mail:** Marine@Perkins.com

[www.perkins.com/Marine](http://www.perkins.com/Marine)

## Foreword

Thank you purchasing the Perkins M300C, M250C, M216C & M190C marine diesel engine. This manual contains information for the correct installation of your Perkins engine.

Information contained in this manual is correct at the time of printing. Wimborne Marine Power Centre reserves the right to make changes at any time. If there are any differences between this manual and your engine, please contact the Wimborne Marine Power Centre.

## General safety precautions

These safety precautions are important. You must refer also to the local regulations in the country of use. Some items only refer to specific applications.

- Only use these engines in the type of application for which they have been designed.
- Do not change the specification of the engine.
- Do not smoke when you put fuel in the tank.
- Clean away fuel which has been spilled. Material which has been contaminated by fuel must be moved to a safe place.
- Do not put fuel in the tank while the engine runs (unless it is absolutely necessary).
- Do not clean, add lubricating oil, or adjust the engine while it runs (unless you have had the correct training; even then extreme care must be used to prevent injury).
- Do not make adjustments that you do not understand.
- Ensure that the engine does not run in a location where it can cause a concentration of toxic emissions.
- Other persons must be kept at a safe distance while the engine, auxiliary equipment or boat is in operation.
- Do not permit loose clothing or long hair near moving parts.
- Keep away from moving parts during engine operation.
- If your skin comes into contact with high-pressure fuel, obtain medical assistance immediately.
- Diesel fuel and lubricating oil (especially used lubricating oil) can damage the skin of certain persons. Protect your hands with gloves or a special solution to protect the skin.
- Do not wear clothing which is contaminated by lubricating oil. Do not put material which is contaminated with oil into the pockets of clothing.
- Discard used lubricating oil in accordance with local regulations to prevent contamination.
- Use extreme care if emergency repairs must be made at sea or in adverse conditions.
- The combustible material of some components of the engine (for example certain seals) can become extremely dangerous if it is burned. Never allow this burnt material to come into contact with the skin or with the eyes.
- Always close the seacock before the removal of any component of the auxiliary water circuit.
- Wear a face mask if the glass fibre cover of the turbocharger is to be removed or fitted.
- Always use a safety cage to protect the operator when a component is to be pressure tested in a container of water. Fit safety wires to secure the plugs which seal the hose connections of a component which is to be pressure tested.
- Do not allow compressed air to contact your skin. If compressed air enters your skin, obtain medical help immediately.

**Warning!** *Some moving parts cannot be seen clearly while the engine runs.*

- Do not operate the engine if a safety guard has been removed.
- Do not remove the filler cap or any component of the cooling system while the engine is hot and while the coolant is under pressure, because dangerous hot coolant can be discharged.
- Do not use salt water or any other coolant which can cause corrosion in the closed circuit of the cooling system.
- Do not allow sparks or fire near the batteries (especially when the batteries are on charge) because the gases from the electrolyte are highly flammable. The battery fluid is dangerous to the skin and especially to the eyes.
- Disconnect the battery terminals before a repair is made to the electrical system.
- Only one person must control the engine.
- Ensure that the engine is operated only from the control panel or from the operators position.



Chapter ..... Page

<b>1 Location of engine installation points.....</b>	<b>1</b>
<b>2 Engine mounting .....</b>	<b>3</b>
Installation angles .....	3
Nose down capability.....	3
Engine mounting brackets .....	4
Flexible engine mounts.....	5
Engine bearers.....	6
<b>3 Propeller shafts and couplings .....</b>	<b>7</b>
Propeller shafts .....	7
<b>4 Exhaust systems .....</b>	<b>9</b>
Wet systems.....	9
Dry systems .....	11
Part dry, part wet systems .....	12
Water lift systems .....	12
Silencers.....	13
<b>5 Engine room ventilation.....</b>	<b>15</b>
<b>6 Engine cooling systems .....</b>	<b>17</b>
Auxiliary water systems.....	17
Keel cooling system.....	18
<b>7 Fuel systems.....</b>	<b>19</b>
Cleanliness of fuel system components .....	19
Cleanliness of the engine .....	19
Environment .....	19
New components.....	19
Refuelling .....	19
Fuel connections.....	19
Thread details of the connections on the engines for fuel pipes ...	20
Typical fuel systems .....	21
Alarm tank.....	22
<b>8 Engine electrical systems.....</b>	<b>23</b>
Engine wiring looms .....	23
Breakers .....	24

Interconnecting cables .....	25
Instrument panels.....	26
Main panel.....	26
Auxiliary panel.....	27
Mini Marine Power Display (MMPD) digital panel.....	28
Keyswitch panel .....	28
Throttle synchronization / slow vessel mode panel .....	29
Possible panel configurations.....	30
Mini Marine Power Display (MMPD) instructions .....	31
CAN Data Link .....	35
For engines without an MJB (Marine Junction Box).....	36
For engines fitted with the Marine Junction Box (MJB) .....	37
Single engine MJB features and mounting details .....	38
Twin engine MJB features and mounting details .....	39
Power connections .....	40
Current requirements 12 or 24 vdc system .....	40
ECM port or starboard interface connectors.....	40
Grounding the battery negative .....	40
Port or starboard expansion connectors.....	41
Diagnostic lamp (Pin 2).....	42
Warning lamp (Pin 1).....	42
- Battery (Pin 11).....	42
Keyswitch (Pin 12).....	42
Maintenance Clear switch (Pin 16) .....	42
Cold start system .....	43
Cold start data 12V and 24V .....	43
Battery performance .....	43
Battery to starter lead resistance .....	43
Battery isolator switches.....	44
Zinc Anode bonding system .....	44
Typical system in common use .....	45
Optional sensors .....	45
Wiring diagrams .....	47
*Engine wiring harness overview, without MJB .....	47
*Engine wiring harness, wiring description, without MJB .....	48
*Engine wiring harness overview .....	49
*Panel harness overview .....	50
*Engine wiring harness 1.....	51
*Engine wiring harness 2.....	52
*Engine panels 1.....	53
*Interconnecting leads 1 .....	54
*Master/slave option, port .....	55
*Marine junction box .....	56
*Master/slave option, starboard.....	57
*Interconnecting leads 2.....	58
*Engine panels 2.....	59



<b>9 Engine controls .....</b>	<b>61</b>
<b>10 Provision for power take-off.....</b>	<b>63</b>
For axial drives .....	63
For belt drives.....	63
Polar diagram.....	64
<b>11 Calorifier and block heater connections .....</b>	<b>65</b>
Calorifier.....	65
Block heater connection points .....	65
<b>12 Options .....</b>	<b>67</b>
Gearbox oil temperature sensor .....	67
<b>13 Reference data.....</b>	<b>69</b>
Basic data M300C, M250C, M216C, M190C .....	69
Cooling .....	69
Fuel system.....	70
Air intake .....	70
Lubricating system.....	71
Electrical system .....	71
Cold start limits .....	71



### Location of engine installation points

Exhaust Systems  
(See chapter 4)

Starter Cables (See  
chapter 8)

Bonding Stud  
(See chapter 8)

Front Lifting Eye

**Warning!**  
Use spreader bar.

Ventilation (See  
chapter 5)

Fuel Feed (See  
chapter 7)

Cooling Systems  
(See chapter 6)

Engine Mounting Point  
(See chapter 2)

Mounting Brackets  
(See chapter 2)

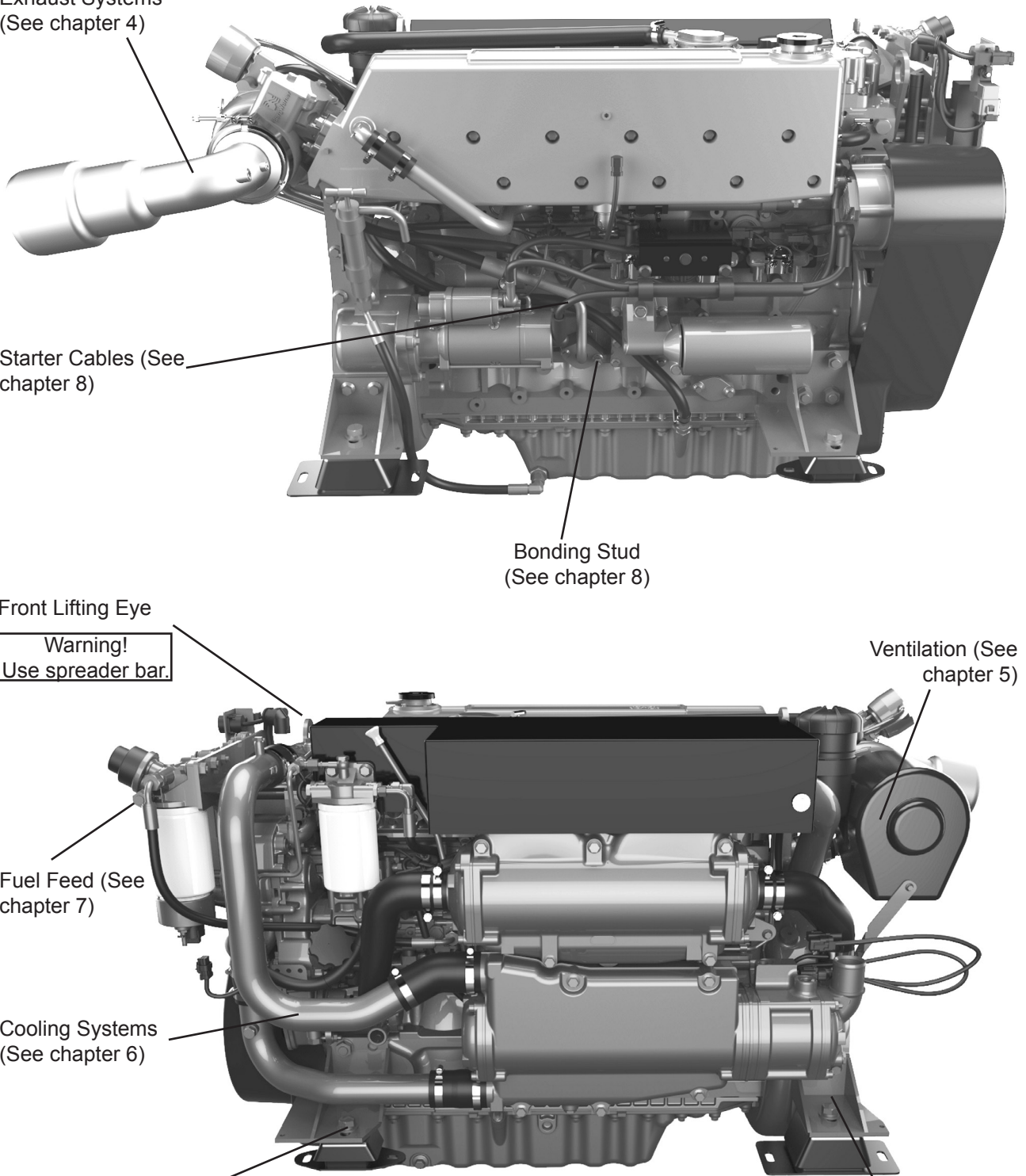

Engine side views

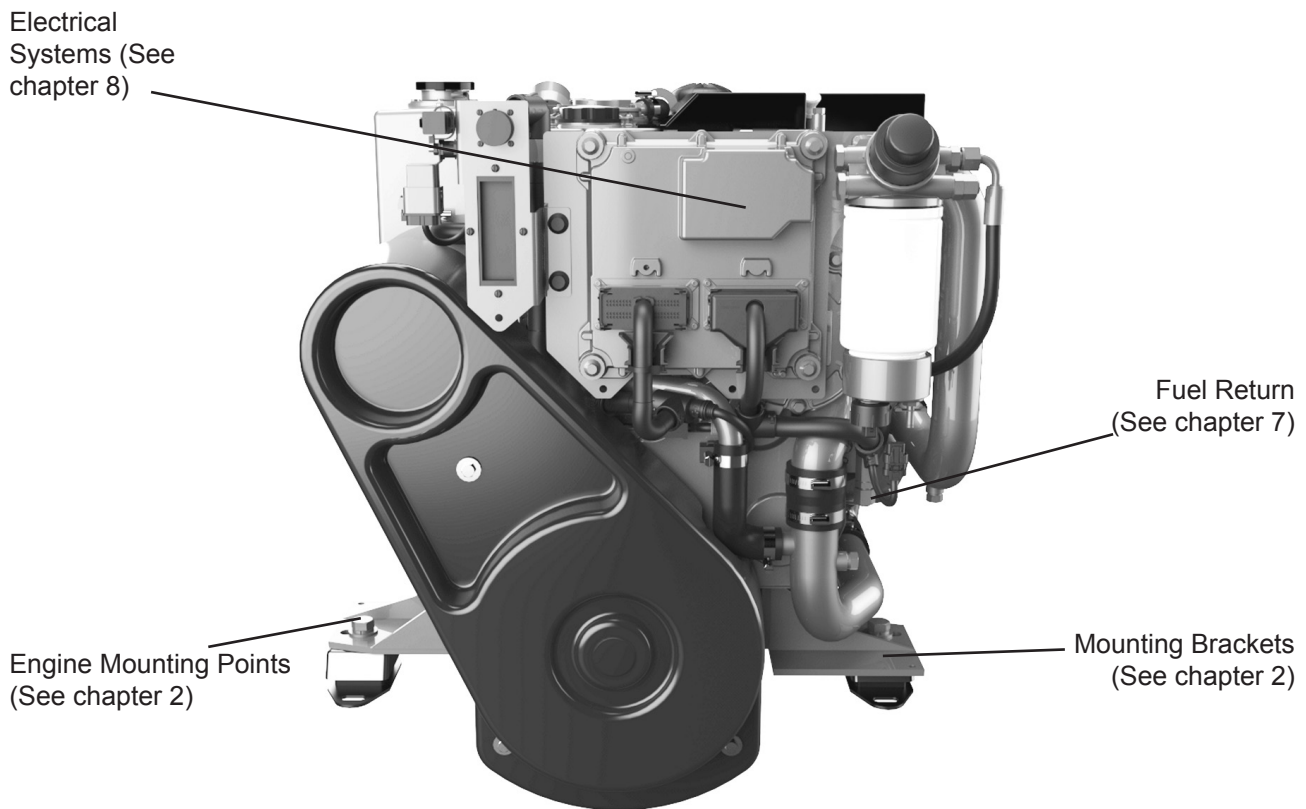
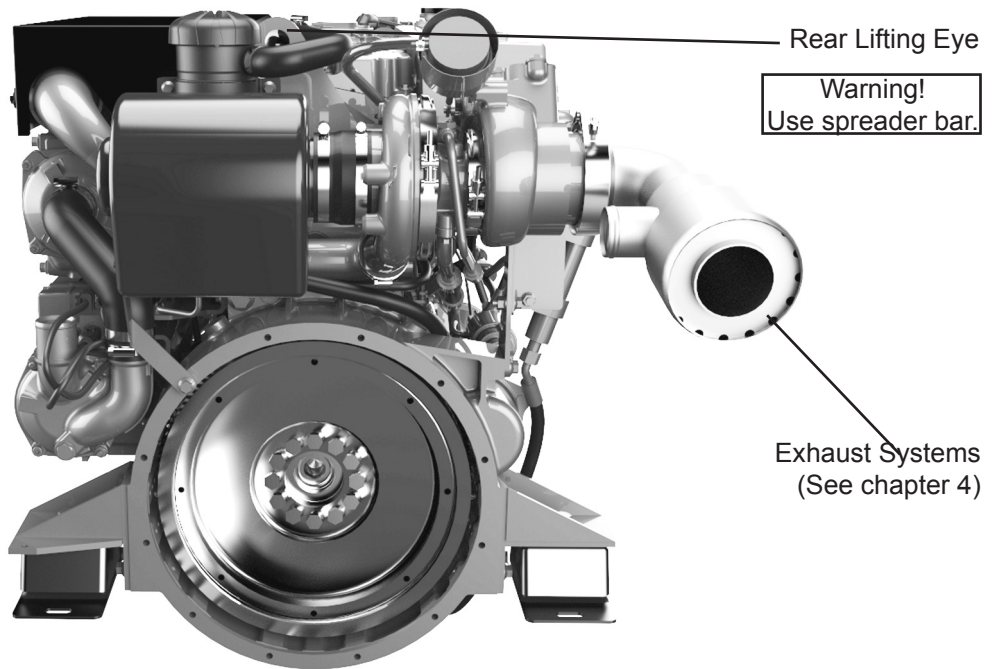

Engine end views

## Engine mounting

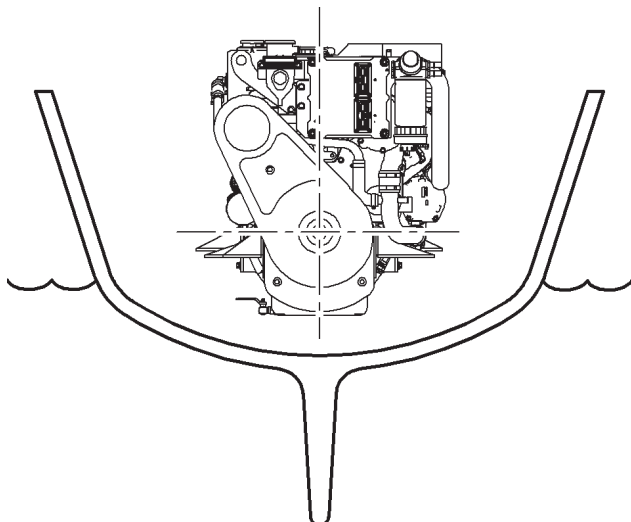

Figure 1

### Installation angles

These engines are intended to be mounted so that the cylinders are vertical, when viewed from ahead or astern as in figure 1. The operational angles that are permissible in service are a static installation angle of 17° nose up, adding 3° for planing craft, with a heel angle of 25° continuous and 35° as shown in figures 2 and 3.

### Nose down capability

These engines are capable of an 8° nose down capability as standard.

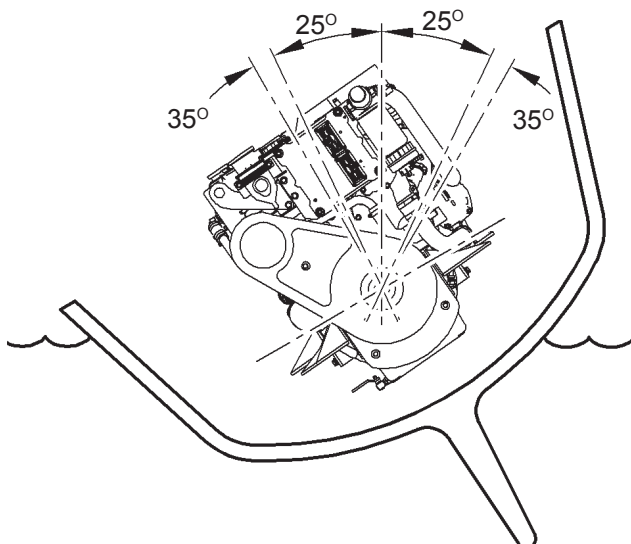

Figure 2

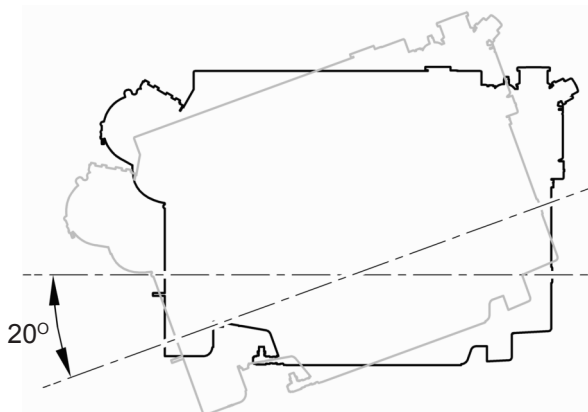

Figure 3.

## Engine mounting brackets

The standard brackets, provide mounting points which are 76mm (3") below, and parallel with, the crankshaft centre line. The brackets may be used to mount the engine directly on the engine bearers, but for all applications it is recommended that flexible engine mounts are used.

Figure 4 shows the holes (1) for the holding down bolts are slotted, 36 x 17 (1.7/16 x 21/32") to allow for some movement during the final stages of alignment. Where fine alignment is not necessary, for example when a flexibly jointed drive shaft is used, the bolts on all four corners of the engine should be positioned at the end of the slot - all either fully in or fully out. This will provide additional security in the fixing arrangements.

**Note:** Please refer to the GA (General Arrangement) drawings for specific engine mount positions.

For any non standard options, please contact the Wimborne Marine Power Centre for advice.

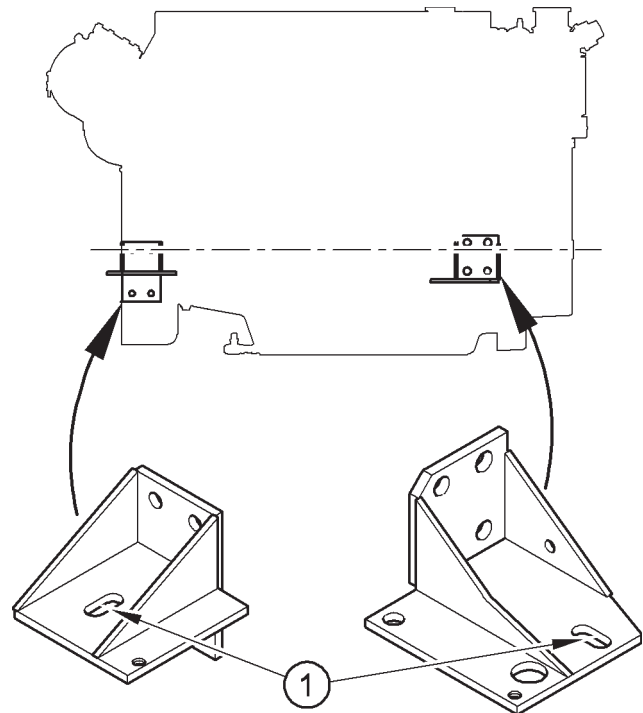

Figure 4

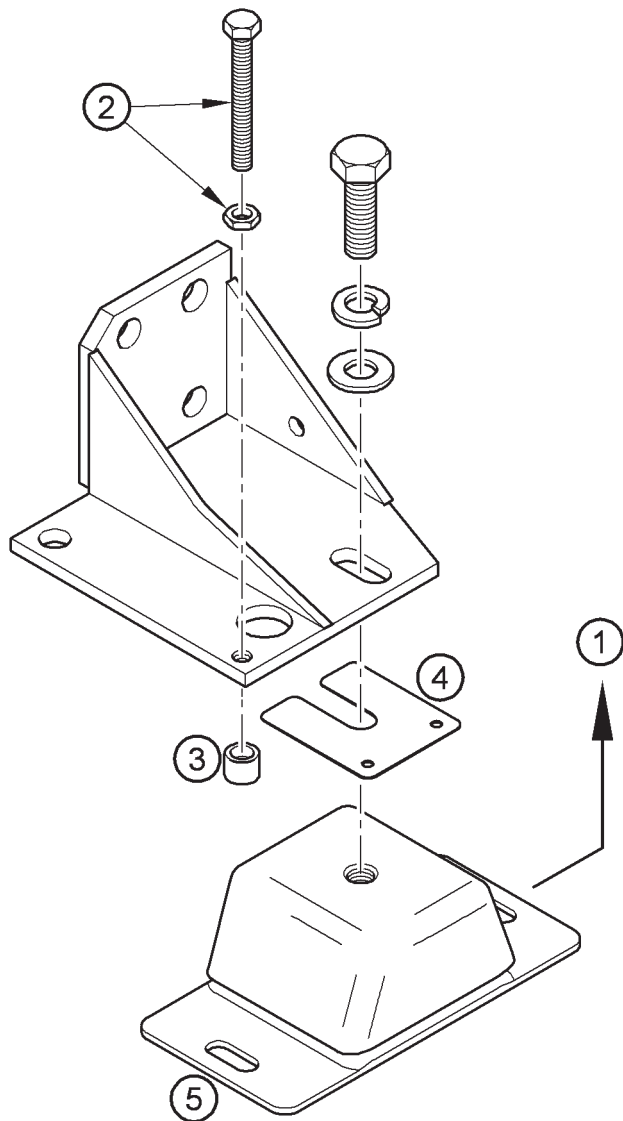

Figure 5

### Flexible engine mounts

It is recommended that flexible engine mounts should be used for all applications. The principal purpose of the mounts is to reduce the transmission of vibration from the engine to the hull, but another valuable advantage is that the mountings reduce the shock transmitted from the hull to the engine under adverse weather conditions and also prevent the engine being inadvertently used as a structural part of the boat, due to flexing in the hull, a function the engine will not satisfactorily fulfil.

Figure 5 shows the flexible engine mount for most applications.

**Note:** refer to the installation drawing for specific dimensions, which are for the mount in the unloaded condition.

To adjust the height of the mount, use the adjuster nut and bolt (2) against the pad (3) to introduce shims (4). A maximum of thirteen shims per mount can be used, eleven at 1mm thick and 2 at 0.5mm thick.

Radially slotted holes (5) can be utilised to obtain the optimum position.

Engines used with unusual drive arrangements, such as 'V' drives when integral with the engine unit, pose special mounting problems and recommendations as to the most suitable mounting arrangement can be made for specific applications.

**Note:** For transmission ratios above 2:1 or use in extreme conditions, please contact your local distributor for advice.

Installation drawings are available showing the preferred mounting arrangements when using a variety of gearboxes and applications.

## Engine bearers

The materials and methods of construction of engine bearers which have proved to be satisfactory in service vary to such an extent that it is difficult to lay down universal guide lines. However, as a rough guide it can be said the engine bearers should be capable of supporting a static load of about eight times the weight of the engine, to cater for the effects of rough seas.

The bearers should be cross connected to give lateral rigidity, in order to maintain the shaft alignment and to prevent twisting and racking forces being applied to the engine.

To enable minimum shaft centre distances to be achieved in a twin installation, a common centre bearer supporting the inner mountings of both engines is sometimes used as shown in figure 6. By this method shaft centres down to 783mm (31") may be adopted, but wider spacing is desirable.

The shaft centres could be theoretically reduced further, but this would result in the engine accessibility becoming very restricted, and it would be impossible to carry out service operations. It should be noted that if minimum shaft centres are to be adopted, space must be left in front of and behind the engine to provide access. A minimum clearance on all sides will mean that the engine cannot be serviced!

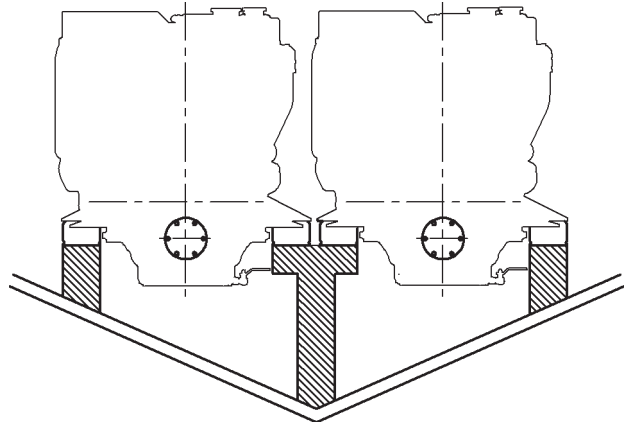

**Figure 6**



## Propeller shafts and couplings

### Propeller shafts

It is recommended that all engines are mounted on flexible mountings (1), which will reduce noise and vibration, and will prevent hull movements resulting in forces being applied to the engine.

The responsibility for the design and installation of the transmission system connected to the gearbox lies with the boat designer, the boat builder, the naval architect or the engine installer. It is recommended that a Torsional Vibration Analysis (TVA) is carried out on the complete drive system. Mass Elastic Data can be provided on request from Wimborne Marine Power Centre.

Figure 1 shows a simple arrangement, where the propeller shaft is supported only by the gearbox coupling and an outboard rubber bearing at the propeller end. Entry of water into the boat is prevented by a shaft seal, which must be flexibly mounted to allow for engine movement. A flexible shaft coupling (2) is fitted to the gearbox coupling, to allow momentary angular misalignment in operation.

This system is only suitable for applications where the speed, diameter, and unsupported length of the propeller shaft will not induce 'whirling' (i.e. the centrifugal force generated by the speed of rotation is not sufficient to bend the shaft into a bow shape).

Figure 1 also shows a cutless bearing (3), flexibly mounted shaft seals (4), reinforced rubber hose (5), graphited asbestos string (6), stuffing box (7) and the drive shaft (8).

Where the propeller shaft length is such that it cannot be simply supported by the gearbox coupling and 'P' bracket, without the risk of whirling, the arrangement shown in figure 2 may be adopted.

Water supply (4) for bearings (use hose from M14 x 1.5 tapping on heat exchanger end cap). End cap with tapping is optional.

In this case one or more additional bearings (3) are included in the shaft log, and flexible shaft couplings (2) (which will accept thrust) are used to permit the engine to move on the flexible mountings (1).

**Warning!** Use a syphon break (5) where a water lift exhaust system is specified.

A variation of this is to use a thrust block (bearing) at the point where the shaft emerges from the log into the engine room, together with constant velocity joints at each end of the short shaft connected to the gearbox coupling.

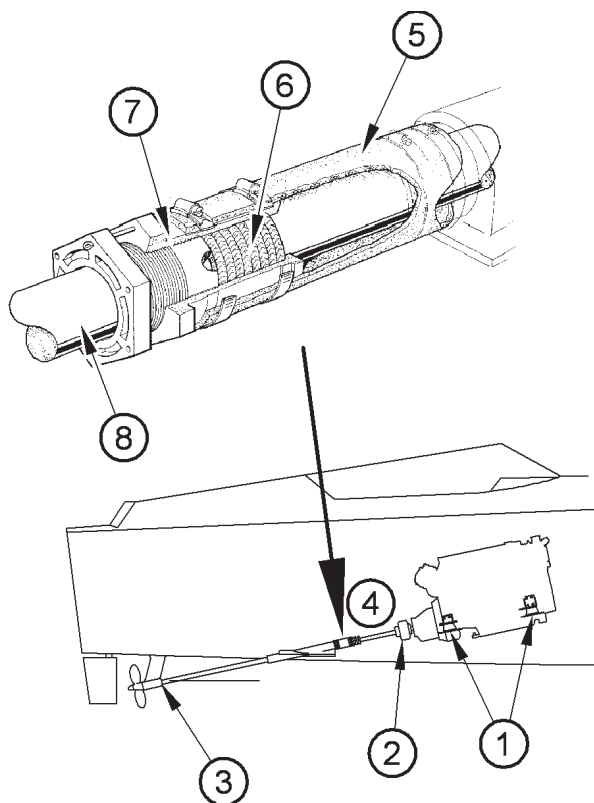

Figure 1

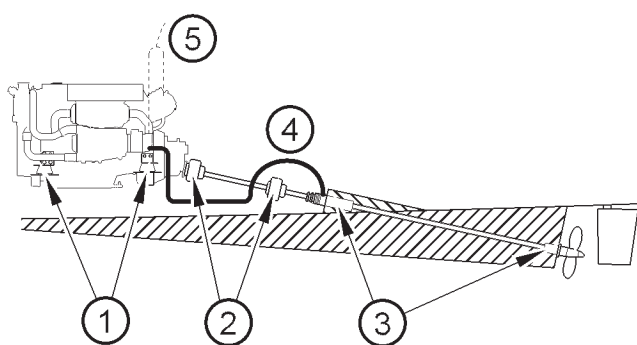

Figure 2



## Exhaust systems

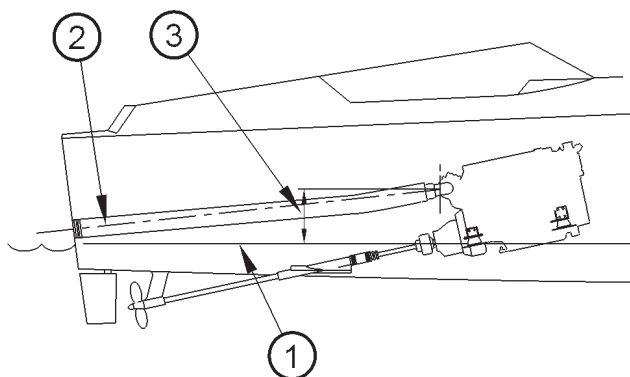

Figure 1

A range of exhaust components are available for use with all types of exhaust system. The components are designed to connect together, allowing complex systems to be built from stock items, to suit most installations.

**Caution:** In all types of exhaust system the exhaust back pressure must not exceed 15kPa, when measured within 305mm (12 inches) of the exhaust outlet from the engine.

### Wet systems

Wet exhaust systems, where the auxiliary water used to circulate through the heat exchangers on the engine is finally dumped into the exhaust pipe to cool the exhaust gases, are the most common choice for small craft. Their principal advantage is that a rubber exhaust hose may be used, with a fairly low surface temperature, which presents no risk of fire.

The exhaust bore is 125mm (5").

A general arrangement for such a system is shown on Figure 1. In many cases the exhaust outlet passes through the transom, just above the waterline (1). It will be seen that a minimum fall of 5° (2) is required, and that the point of water injection must be at least 8 inches above the waterline (3), although the actual height necessary for a particular boat can only be decided in the light of the exhaust system design, and the pitch and roll which may be encountered in service.

**Caution:** It is essential that the exhaust system is designed so that water from the exhaust does not enter the engine under any conceivable operational condition.

Figure 2 shows the exhaust elbow (1) with water injection and insulating blanket (3) & (4). The elbow can be rotated (2) to achieve the optimal position.

**Note:** The exhaust elbow must have a fall of 10° downwards.

If a taller system is required then a dry 90° elbow (not shown) can be used on the turbocharger outlet with the water injected elbow (1). As both elbows use a clamp, full articulation can be utilised to suit most applications

**Note:** The clamps are to be torqued to 9Nm.

Due consideration must be given to providing flexibility in the exhaust hose, particularly if the engine is flexibly mounted. Where the exhaust hose must pass through a bulkhead immediately behind the engine it is preferable that the arrangement shown in figure 3 is adopted, using rubber bellows (1) to provide flexibility.

**Note:** that the bellows should be in an unstrained condition when fitted, a minimum fall of 5° (3) is required, and that the point of water injection must be at least 8 inches above the waterline (2).

**Note:** A single double hump bellows can be used where space is restricted.

**Caution:** Movement of the engine on the flexible mounts must not be restricted by the exhaust hose.

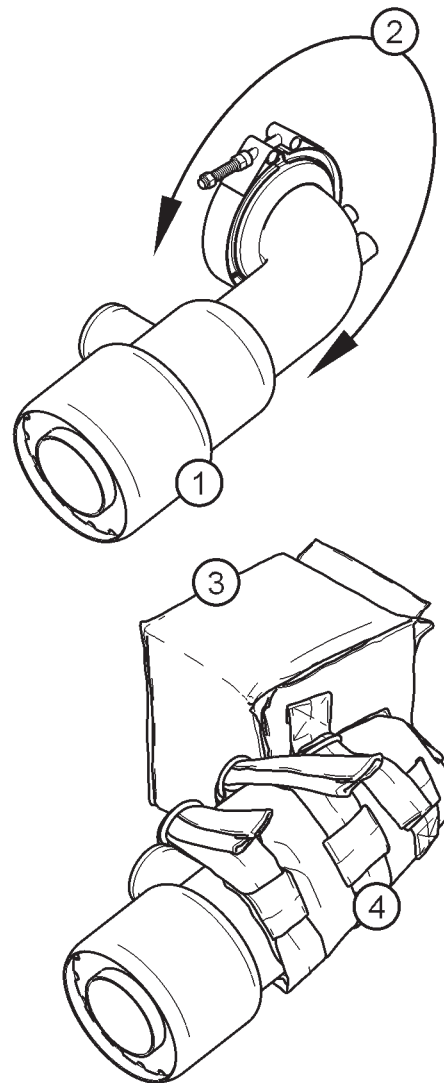

Figure 2

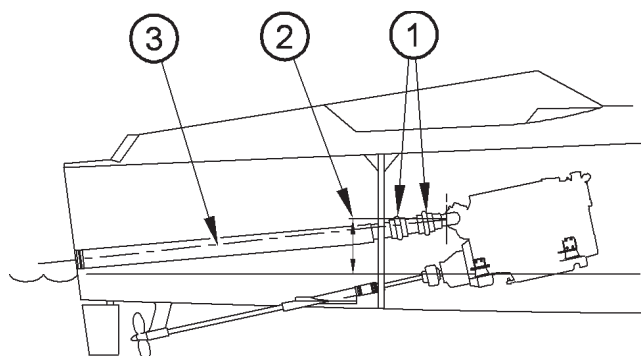

Figure 3

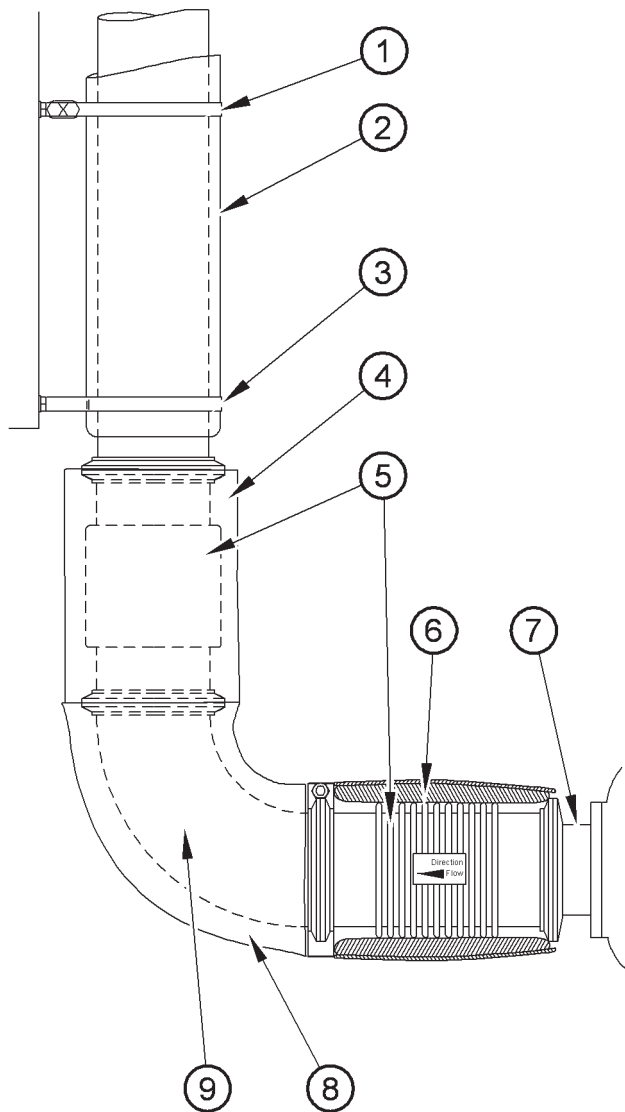

Figure 4

### Dry systems

Dry exhaust systems for marine installations need careful design to minimize the disadvantages of enclosing components that are at a high temperature in confined spaces.

The first part of a dry system should include a flexible connection so that excessive weight is not carried by the connection to the engine. Connections of the stainless steel bellows type are suitable, but care must be taken to ensure that they are only required to accommodate movements that do not involve twisting the ends of the bellows relative to each other.

The remainder of the exhaust system should be well insulated to avoid fire risk.

If there is a long exhaust run which gains height as it leaves the engine, it may be necessary to incorporate a trap to collect condensate and allow it to be drained.

Figure 4 shows a typical system. The minimum bore of the exhaust pipe should be 85mm (3.34 inches).

(1) Bracket with link to allow for movement due to expansion in the exhaust system (horizontal exhaust systems should be suspended from the deck head using similar brackets - rigid brackets should not be used).

(2) Insulating lagging.

(3) Rigid bracket to support the weight of the vertical exhaust system.

(4) Heat blanket.

(5) Twin stainless steel bellows fitted to avoid torsional load on bellows unit.

(6) Heat blanket.

(7) Turbocharger adaptor.

(8) Heat blanket.

(9) 90° Elbow.

**Note:** When fitted, the bellows units should be in an unstrained condition so that the full bellows movement is available to absorb expansion and engine movement.

### Part dry, part wet systems

Even where the engine is mounted well below the waterline the advantages of a wet system can still be gained, providing that water injection takes place at a point sufficiently above the waterline.

In these circumstances the part dry, part wet system shown in figure 5 can be utilised. The modular exhaust components allow a system to be readily constructed, utilising a tall dry riser, followed by a water injection elbow.

- (1) Stainless steel bellows.
- (2) Optional high rise extension - not factory supplied.
- (3) Flexible hanger.
- (4) Point of water injection to be 200mm (8 inches) minimum height above water line.
- (5) 5° minimum average fall.
- (6) Water line.

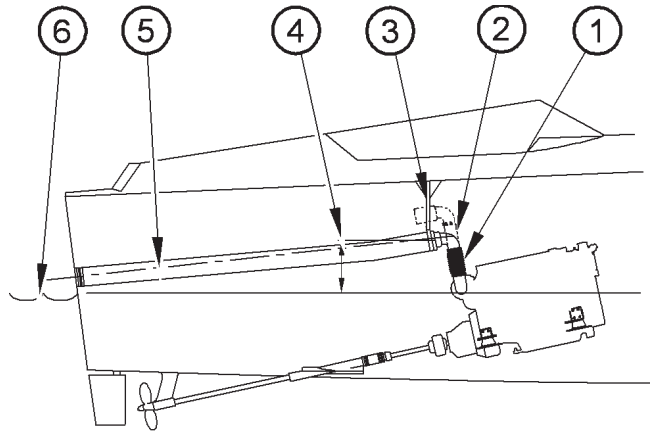

Figure 5

### Water lift systems

Figure 6 shows the main features of such a system, which utilises pressure developed by the exhaust gases to force a mixture of gas and water to a height which may be considerably above the engine. When the engine is stopped the exhaust tank contains the water which falls back from the exhaust riser.

If a proprietary unit is used the manufacturers instructions should be carefully followed, but figure 5 identifies the key features.

- (1) Exhaust tank (water lock).
- (2) Water injection elbow.
- (3) To overboard outlet.
- (4) 1/2" bore siphon break.
- (5) Top of exhaust riser and point at which the siphon break is connected to the engine pipe work must be above the water line under the worst possible conditions (normally a distance of 450mm (18") under static conditions will be sufficient)
- (6) Exhaust riser.

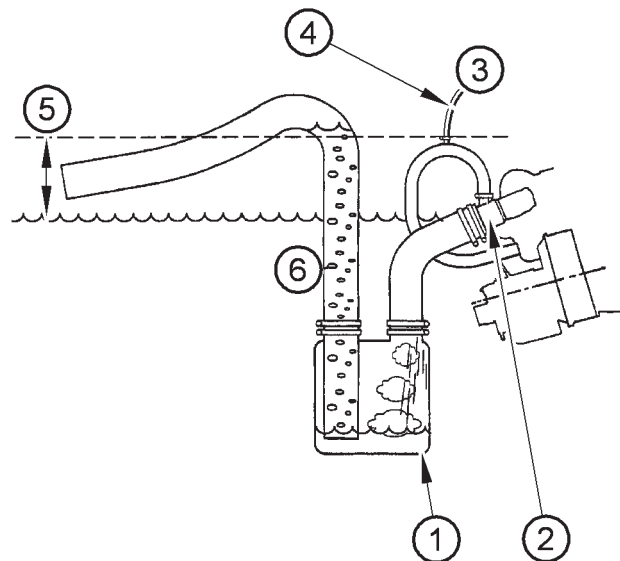
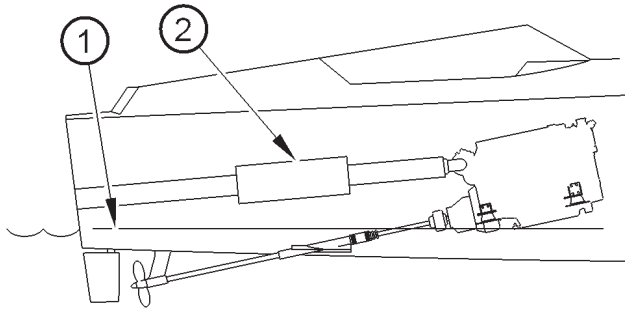

Figure 6

**Note:** that the system must meet the requirement for the maximum exhaust back pressure to be not greater than 15kPa, measured within 305mm (12 inches) of the turbocharger/ exhaust outlet. Minimum volume of exhaust tank should be 3 times the volume of the water in the riser. The tank should be installed near the centre-line of sailing craft.



**Figure 7**

### Silencers

In some applications a reduction in noise levels from the exhaust would be desirable and to that extent, a silencer can be fitted.

The exhaust system ejects the cooling water as well as silencing the engine's combustion noise and removing the exhaust gases. The system must create minimal restriction to the flow of exhaust gases, known as back pressure, or the engine may be damaged.

Figure 7 shows an engine sited well above the waterline (1), with a gradient steeper than  $5^{\circ}$  to the back of the boat. The water will run naturally down the exhaust to the stern. To reduce noise a straightforward in-line silencer (2) should be used.

**Note:** The above is used in relation to 15kPa.





## Engine room ventilation

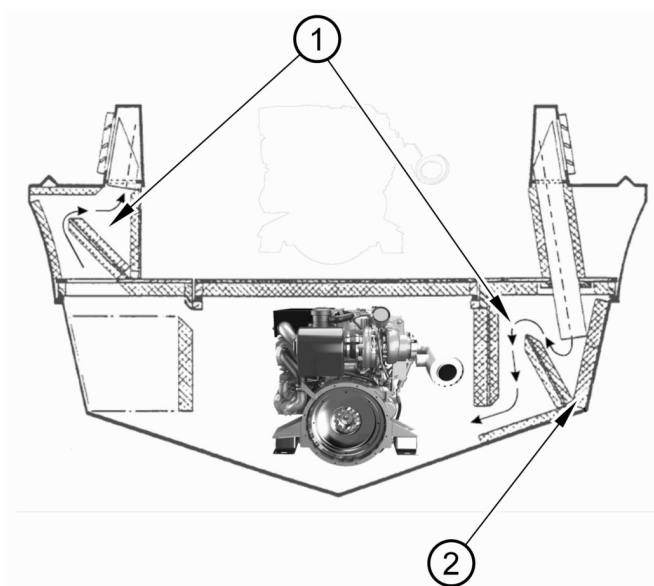

**Figure 1**

The engine room must be ventilated for two reasons:

1. To supply the engine with air for combustion.
2. To provide a flow of air through the engine room to prevent an excessive temperature build up, which may cause components such as the alternator to overheat.

**Note:** The air temperature entering the engine should not exceed 52°C (126°F). The air temperature entering the engine room should not exceed 60°C (140°F).

In most applications in temperate climates, the engine will draw air from the engine room. If this is the case then, as a rough guide, it can be taken that every horsepower produced by the engines requires, as a minimum, 161 sq. mm, (6.34 sq.ins.) of vent area. If the boat is likely to be used in hot climates, and if engine room ventilation fans are fitted, then a vent area of 322.58 sq.mm (12.7 sq.ins.) per horsepower should be provided. Wherever possible a flow of air through the engine room should be encouraged by using forward facing intake vents to take advantage of ram airflow, together with other vents to allow hot air to escape.

Noise absorbing chambers (1) with deflector baffles and noise absorbent material (2) are positioned to direct ventilation air flow over a large surface area of absorbent material.

Cross sectional area of air flow path must not be too small.

With an effective ventilation system the engine air intake temperature will be no more than 10°C higher than the outside air temperature.

**Note:** For the minimum cross section of air duct per engine see 'Reference data' at the back of this manual.

The air entry vents should be situated where spray is not likely to enter them and some form of water trap is desirable (see figure 1). Preferably the air ducts should reach the engine compartment at the sides of the hull so that water will fall into the bilge.

When the engines are shut down after a run at high output in high ambient temperature conditions, it will be found that very high air temperatures will build up in the engine compartment. In boats with open cockpits this is usually of no real consequence but if the engines are mounted below a wheel house, then unpleasantly warm conditions may result. In these circumstances engine room ventilation fans are beneficial, preferably arranged to exhaust air from over the engine.



## Engine cooling systems

### Auxiliary water systems

A completely separate sea water system should be provided for each engine to prevent a blockage resulting in the need to shut down more than one engine and a typical system is shown in figure 1.

The water intake fitting (4) should not project appreciably below the bottom of the hull and it should be situated well clear of other components such as shafts, logs, rudders to prevent flow problems at high speeds.

The intake fittings and pipework should have a minimum bore of 32mm (1.25") be provided. This should be of the full flow type giving unobstructed passage to the water in the open position, with a minimum bore of 32mm (1.25").

Between the intake fitting and the sea water pump (1) on the engine, there should be a strainer (5) which should be easily accessible for routine examination, and should be easily removable.

From the sea water strainer a pipe (2) should be run to the sea water pump inlet connection on the engine. The pipe may either be mainly rigid, or for example copper or cupro-nickel, or flexible, but only flexible hose which is reinforced to prevent collapse should be used. Rubber hose connections in the sea water system should be kept as short as possible. The system must be sufficiently flexible to permit the engine to move on its flexible mountings. The sea water pump connection is for hose with a 32mm (1.25") bore.

Care should be taken to use compatible materials in the sea water systems, to prevent excessive electrolytic corrosion. Systems incorporating copper, cupro-nickel, stainless steel Type 316, gun-metal, silver solder, and aluminium brass will generally be satisfactory. Components made from lead, iron, steel, aluminium or its alloys, zinc or magnesium, should be generally avoided. Refer to section 8 on anodes.

**Note:** Where possible mount the strainer (5) so that the top is just above the waterline (6) - to facilitate cleaning.

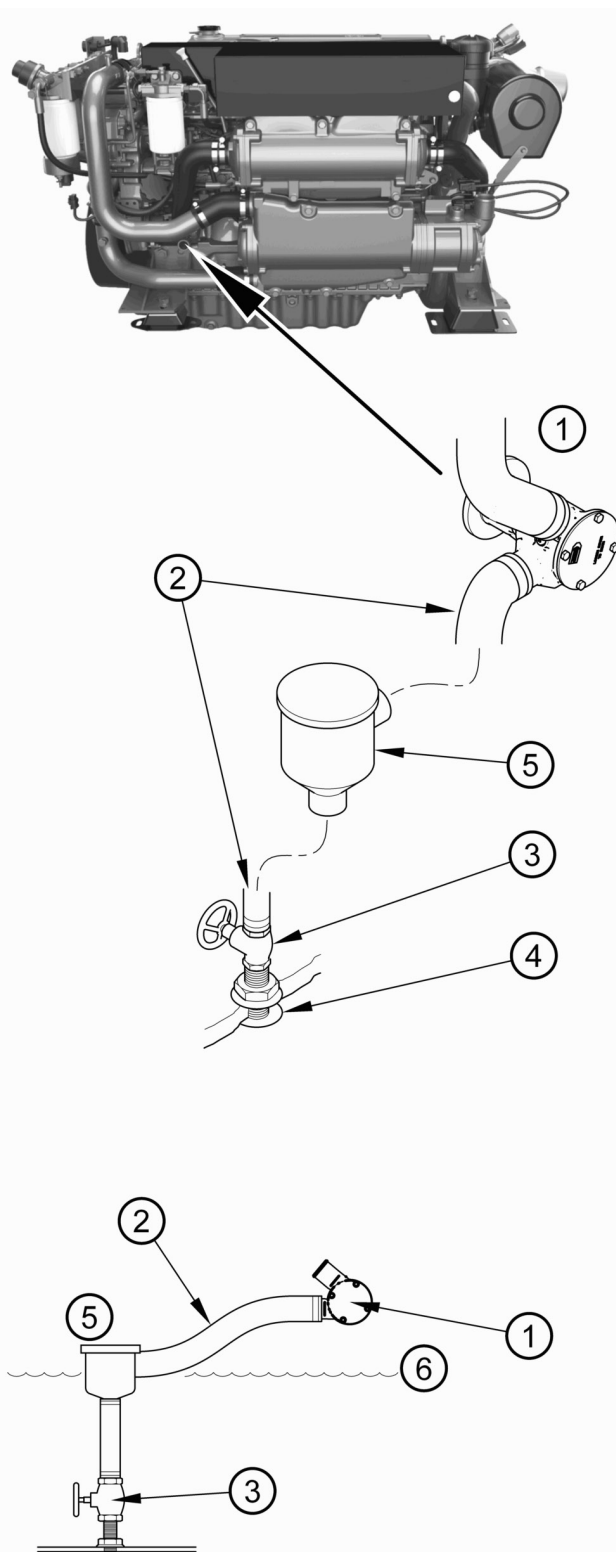

Figure 1

### Keel cooling system

This engine may be purchased in a form suitable for keel cooling, using two separate coolers, one for the cylinder jacket circuit and one for the aftercooler circuit. Figure 2 shows the connections provided for the coolers. The requirements for each section are as follows:

Models	M190C	M216C	M250C	M300C
<b>Cylinder Jacket Circuit</b> Heat rejection /kW.	102	134	146	173
Design value for the water temperature at the exit from the keel cooler /°C.	65	65	65	65
Design value for the water flow through the cooler. *Pipework to suit 45mm (1.75") bore hose connections /l min <sup>-1</sup> .	174	201	201	201
Thermostat opening temperature /°C.	85	85	85	85
<b>Aftercooler Circuit</b> (Includes gearbox oil cooler) Heat rejection /kW.	32	36	42	44
Design value for the water temperature at the exit from the cooler /°C.	38	38	38	38
Design value for the water flow through the cooler. Pipework to suit 32mm (1.25") bore hose connections /l min <sup>-1</sup>	119	133	133	133

**Note:** Under extreme conditions the water flow in the jacket circuit may increase to 182 l/min (40 gallons/min.)

The pipework between the engine and coolers should be as short and direct as is possible, but should be sufficiently flexible to allow the engine to move on it's flexible mountings. The layout should discourage the formation of air locks, and venting points should be provided wherever an air lock is likely to occur.

The keel cooling system should normally be filled with a water/antifreeze mixture containing 50% antifreeze. This mixture is necessary even in warm climates, as the anti freeze contains corrosion inhibitors which protect the engine cooling system.

Figure 3 shows the items not supplied with the engine as unshaded.

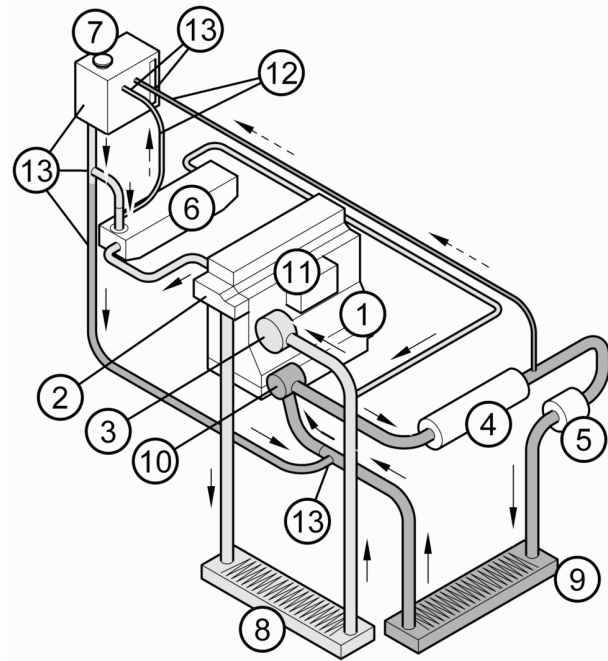

Figure 2

- 1. Engine
- 2. Thermostat
- 3. Fresh water pump
- 4. Aftercooler
- 5. Gearbox oil cooler
- 6. Exhaust manifold
- 7. Remote tank
- 8. Cylinder jacket grid cooler
- 9. Aftercooler grid cooler
- 10. Auxiliary water pump
- 11. Integral oil cooler
- 12. Bleed
- 13. Part of supplied remote kit

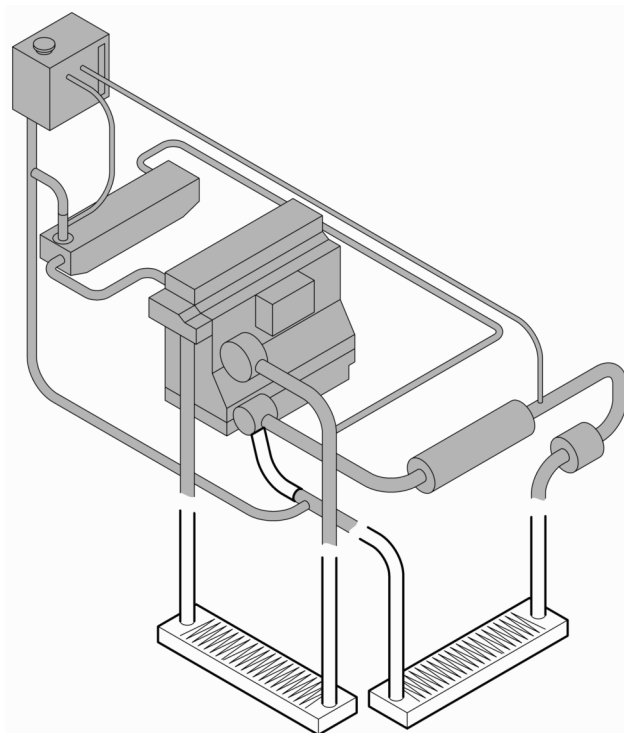

Figure 3

## Fuel systems

### Cleanliness of fuel system components

#### Cleanliness of the engine

---

##### NOTICE

It is important to maintain extreme cleanliness when working on the fuel system, since even tiny particles can cause engine or fuel system problems.

---

Ensure the external surfaces of the engine are clean and dry before commencing work. Remove dirt and loose debris before starting a repair on the fuel system. Ensure that no high pressure water is directed at the seals for the injectors.

#### Environment

When possible, the service area should be positively pressurised with a clean air supply in order to ensure that the components are not exposed to contamination from airborne dirt and debris. When a component is removed from the system, the exposed fuel connections must be closed off immediately with suitable sealing plugs. The sealing plugs should only be removed when the component is reconnected. The sealing plugs must not be reused. Dispose of the sealing plugs immediately after use. Contact your nearest Perkins distributor in order to obtain the correct sealing plugs.

#### New components

High pressure fuel lines are not reusable. New high pressure lines are manufactured for installation in one position only. When a high pressure line is replaced, do not bend or distort the new line. Internal damage to the pipe may cause metallic particles to be introduced to the fuel.

All new fuel filters, high pressure lines, tube assemblies and components are supplied with sealing plugs. These sealing plugs should only be removed in order to install the new part. If the new component is not supplied with sealing plugs then the component should not be used. The technician must wear suitable rubber gloves. The rubber gloves should be disposed of immediately after completion of the repair in order to prevent contamination of the system.

#### Refuelling

In order to refuel the diesel fuel tank, the refuelling pump and the fuel tank cap assembly must be clean and free from dirt and debris. Only use fuel, free from contamination, that conforms to the specifications in the Users Handbook.

Design and assembly faults in the fuel system are responsible for many problems with marine diesel engines. A good system is not hard to achieve, being largely a matter of avoiding obvious pitfalls.

#### Fuel connections

A common reason for service problems with fuel systems is the use of poor or incompatible connectors, where the pressure tightness depends upon the use of sealing compounds, hose clamps, fibre washers trapped between inadequate and unmachined faces, or compression fittings which have been over-tightened to the point where they no longer seal.

Cleanliness during initial assembly is also of vital importance, particularly when fuel tanks are installed, as glass fibres and other rubbish may enter tanks through uncovered apertures.

### Thread details of the connections on the engines for fuel pipes

- Fuel feed - 11/16" ORFS
- Fuel return - 11/16" ORFS

It is strongly recommended that the flexible fuel pipes, available as an option with the engine are used, which are as follows:

#### Fuel feed

The free end of the flexible pipe has a 11/16" ORFS ended fitting, and is supplied with an connector to 1/4" NPT.

#### Fuel return

The free end of the flexible pipe has a 11/16" ORFS ended fitting, and is supplied with an connector to 1/4" NPT.

Fuel tanks should have the following features:

- The filler neck should be raised so that water will not enter when filling.
- The filler cap should seal effectively to prevent water entering when under way.
- A vent pipe should be fitted, again in such a way as to avoid the entry of water.
- The tank should have a sump or angled bottom with a drain tap so that water and sediment can be removed. (This is not always possible).
- Internal baffles may be required to prevent fuel surge.
- The tank should have a removable panel to simplify cleaning.
- The fuel pipe work should be as simple as possible with the minimum of valves and cross connections, so that obscure fuel feed problems are minimised.
- The tank should have at least two connections; a fuel feed connection, and a fuel return connection. Whenever possible a tank should only supply one engine, but in any case each engine should have its own fuel pipes, from tank to engine.

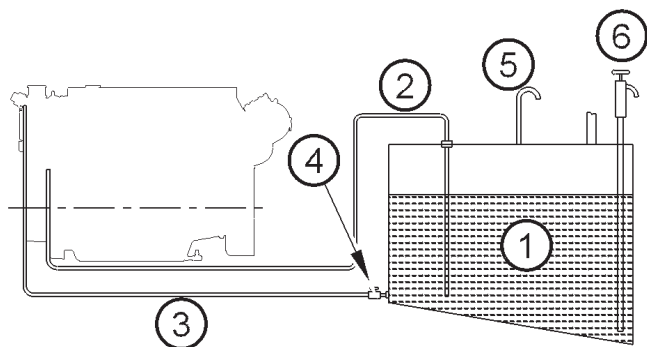

Figure 1

### Typical fuel systems

The more simple the fuel system, the better it will perform in service. Figure 1 shows an ideal system.

1. Fuel tank.
2. Fuel return pipe.
3. Manual fuel feed.
4. Stop cock.
5. Vent.
6. Drain.

In some applications there may be legislation that requires that fuel lines draw from, and return to, the top of the tank. Figure 2 shows an acceptable arrangement.

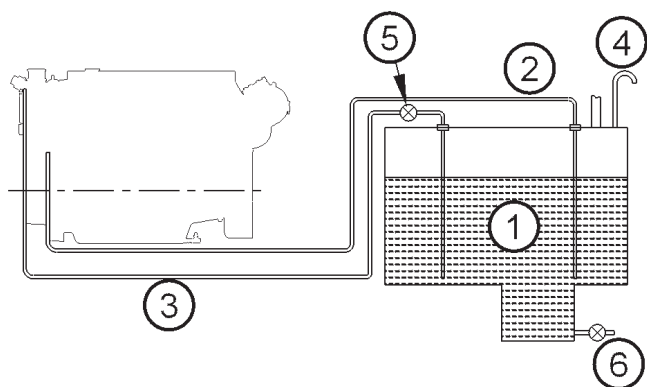

Figure 2

1. Fuel tank.
2. Fuel return pipe.
3. Manual fuel feed.
4. Vent.
5. Fuel feed tap.
6. Drain tap.

The fuel tank may be steel, aluminium, or G.R.P. or, alternatively, a rubber bag tank may be used. The main fuel connection is taken from the rear of the tank so that all the fuel is available for use when under way when the hull will be at an angle. The fuel return is extended within the tank to near the bottom in order to prevent air locks which can arise due to siphoning of the fuel when the engines are stopped.

The fuel lines may be of metal, either copper or 'bundy' steel tubing used either with compression fittings or preferably soldered nipples, with a flexible armoured rubber hose to connect to the primary fuel filter.

This simple fuel system is satisfactory when one or more engines are run from a single fuel tank, and it may also be used when there are two tanks each supplying one engine. In the latter case the system may include a cross connection, between the tanks by means of a balancing pipe, with a valve, at each end. In some installations cross connecting pipes between the two engine feed pipes and the two engine return pipes have been used, but valves are necessary in every line so that the appropriate system may be selected, and the complexity of installation and operation is such that the advantages in operating flexibility are out-weighed by the possibility of obscure problems due to component malfunctions, incorrect operation or engine interaction.

In some cases it is necessary to have a number of fuel tanks in order to achieve the required operating range. In such cases, where possible, one tank should be regarded as the main tank for each engine and the other tanks should be arranged so that they will drain into the main tank by gravity. If a gravity system is not possible, then the system shown in figure 3 should be used.

Figure 3 shows a collector tank (1), fed by all the storage tanks and connected to the engine feed (2) and return systems (3), but with a vent pipe (4) taken to any convenient tank.

There is no doubt however, that a simple fuel system as illustrated in figure 1 should be used wherever possible, as having a completely separate tank and supply to each engine guarantees that if an engine stops, due to running out of fuel or to water or foreign matter in the fuel, the other engine will not be affected simultaneously. This will give some time for appropriate manoeuvring action to be taken. The simple system will also require the minimum number of valves and fittings, which ensures maximum reliability in service.

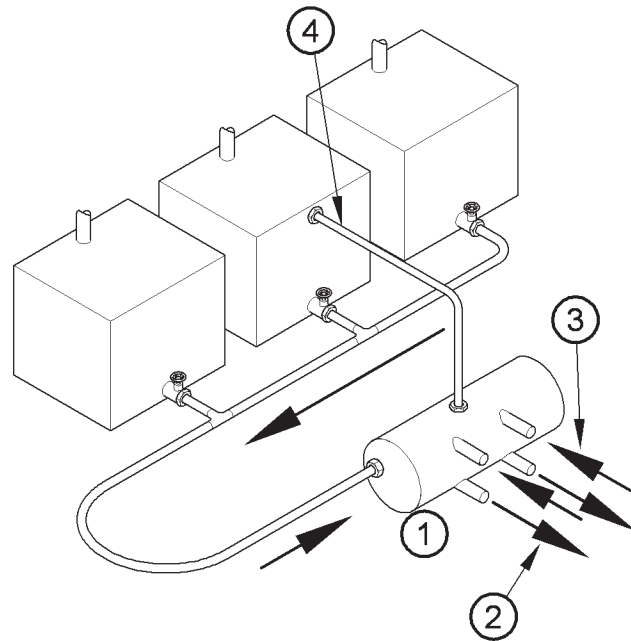

Figure 3

### Alarm tank

If the engine is equipped with duplex fuel pipes the sensor in the alarm tank detects if there is a leak in the inner fuel pipe.

When there is a leak, the fuel will occupy the cavity between the two fuel pipes and flow down to the alarm tank and activate the sensor alerting the operator.

**Note:** Additional monitoring devices are required that are not incorporated within the ECM.

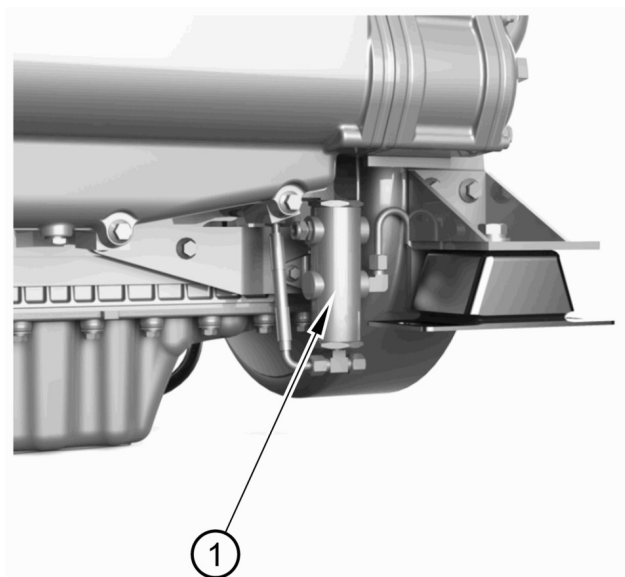



## Engine electrical systems

A plug-together electrical system is available with the engine, providing the following choices from the engine connection:-

- Interconnecting cables of 12m lengths are standard. 3, 6, and 9m lengths are available as options.
- Optional harness to allow multiple instrument panels to be fitted.
- 12V or 24V operation.
- Instrument panels - main, auxiliary or digital, which may be used individually or in combination with a keyswitch panel.

### Engine wiring looms

The engine wiring loom connects the starter, alternator, breakers, electronic engine controller (ECM), electric stop, engine senders and injectors to a waterproof (IP67) multiway connector situated on a flying lead attached to the engine.

The engine circuit diagram can be found at the back of this chapter.

When working on the harness, always secure the harness in the original position with the correct clips and away from pinch points, heat, and sharp edges.

The connectors are keyed to fit in only one direction, which ensures proper pin to socket alignment. Never force connectors, as they should fit together with minimal effort.

Connectors are designed to seal out dirt and moisture without the use of electrical grease.

When servicing the harness, inspect the condition of the seals on the connectors. When pins are unused, be sure to use blanking plugs to protect the connector against dirt and moisture.

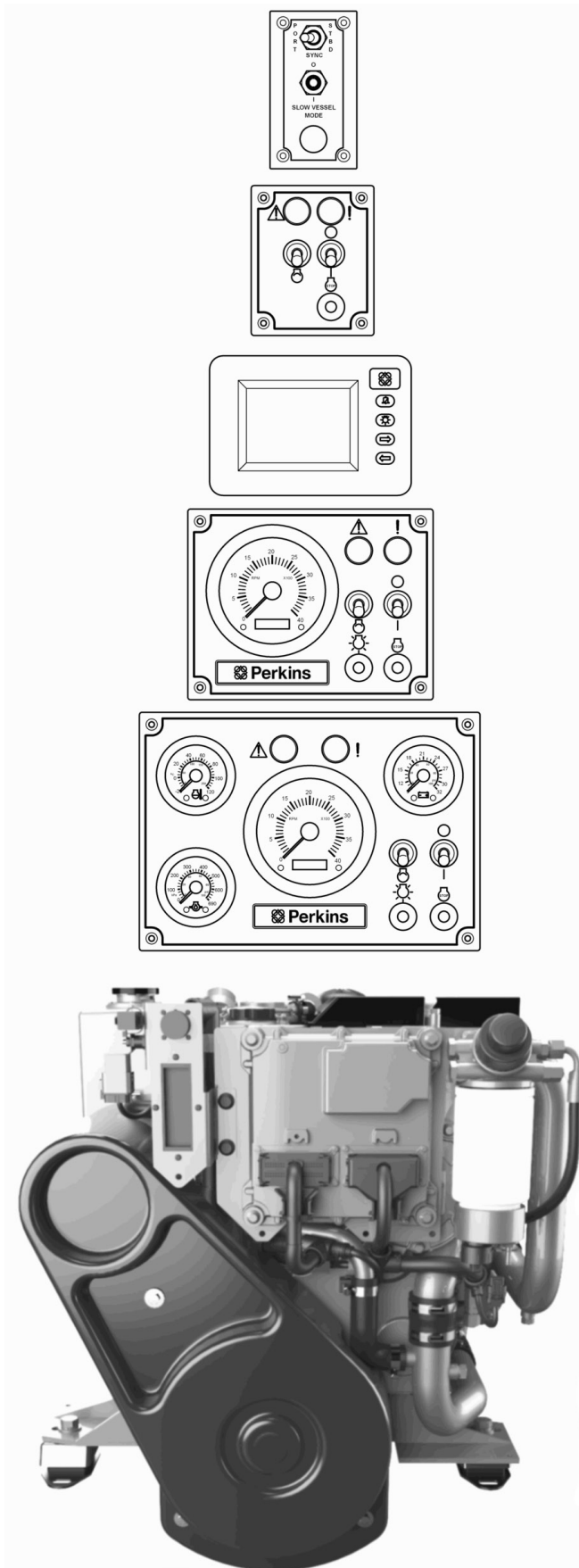

## Breakers

**Note:** Breakers are provided to protect the electrical system against accidental short circuits. The risk is highest when the engine is being installed, or when additional equipment is wired in, and is negligible during normal operation.

The breakers may be found on the right hand side above the oil filter, see figure 1.

- 10Amp - negative glow plug.
- 105Amp - positive glow plug.

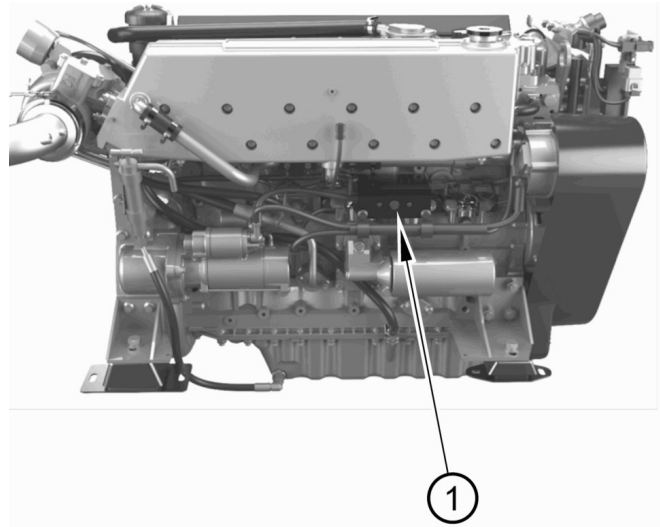

*Figure 1*

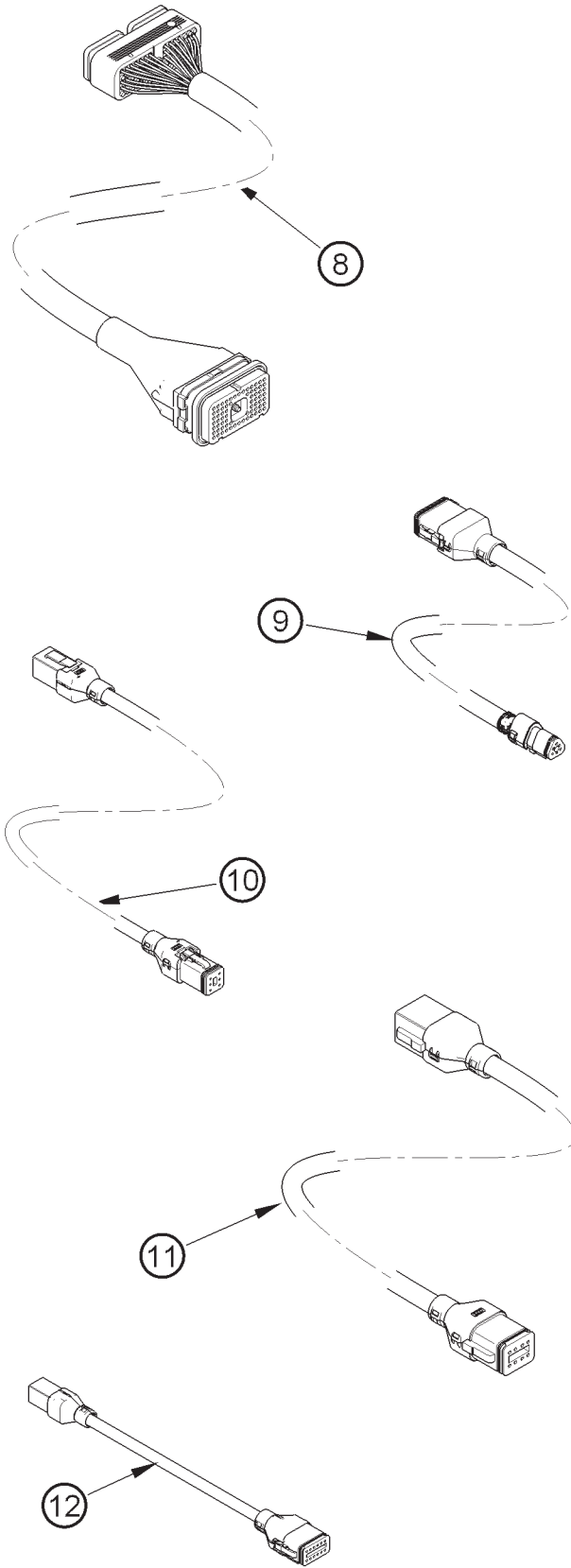

Figure 2

### Interconnecting cables

Interconnecting cables (figure 3) are used to join the engine (1), throttle (3), battery (4), via the marine junction box (2), to the instrument panel(s) (5). Cables are made in a 12m length as standard, 3, 6 & 9 lengths are optional. If a longer cable is required it should be ordered as a special item, to be made in one piece.

Figure 2 shows:

1. Engine.
2. MJB (Marine Junction Box).
3. Throttle.
4. Battery (customer supplied).
5. Instrument panel - main or auxiliary.
6. MMPD, digital panel.
7. Keyswitch panel.
8. Harness, engine to MJB.
9. Harness, throttle.
10. Harness, main or auxiliary panel, J1939 requires tee connector.
11. Harness, keyswitch.
12. Harness, MMPD (digital panel).
13. Battery lead (customer supply).
14. Master/slave lead.

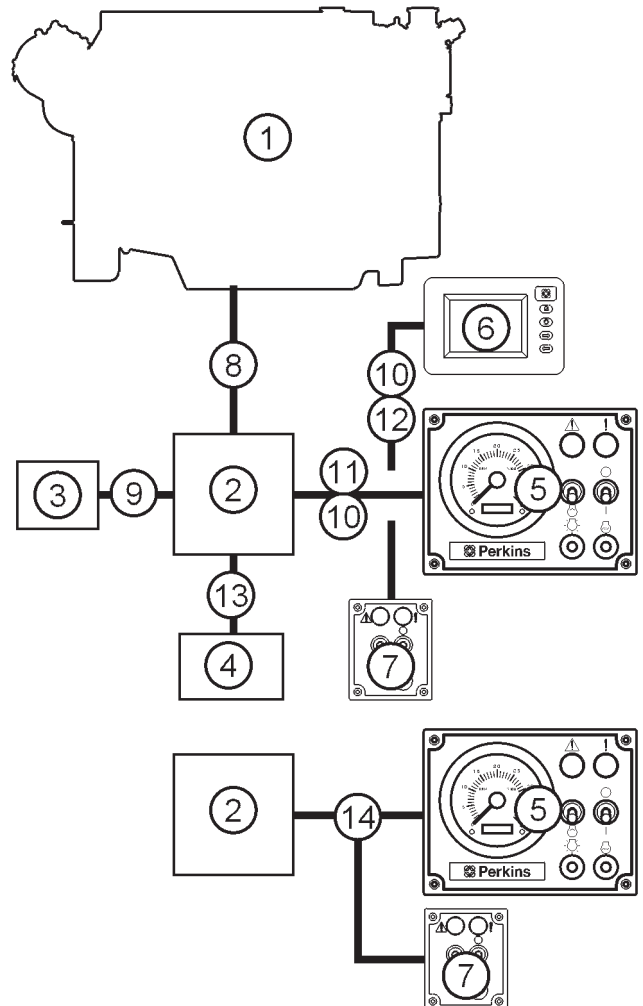

Figure 3

**Instrument panels**

Three types of panel are available, providing different levels of instrumentation.

**Main panel**

- 12 or 24 volt operation from same panel.
- IP 65 rated from front facia, switches/gauges IP67 rated.

The 'Main Panel' shown in Figure 4 is 250mm x 175mm and includes:-

1. Tachometer
2. Engine hours/fault code display
3. Warning light
4. Oil pressure gauge
5. Warning light
6. Water temperature gauge
7. Warning light
8. Warning lamp
9. Diagnostic lamp
10. Engine crank
11. Voltage gauge
12. Warning light
13. Keyswitch on/off
14. Engine stop switch
15. Panel illumination

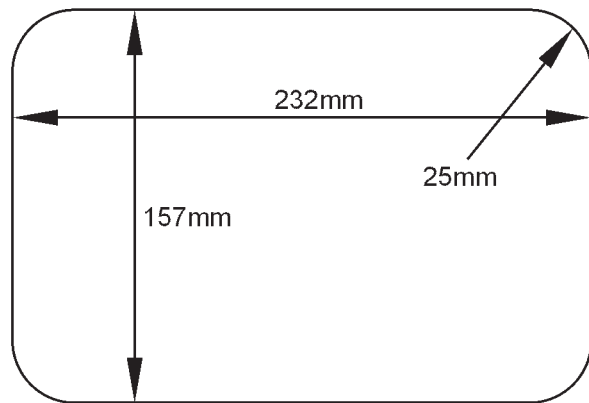
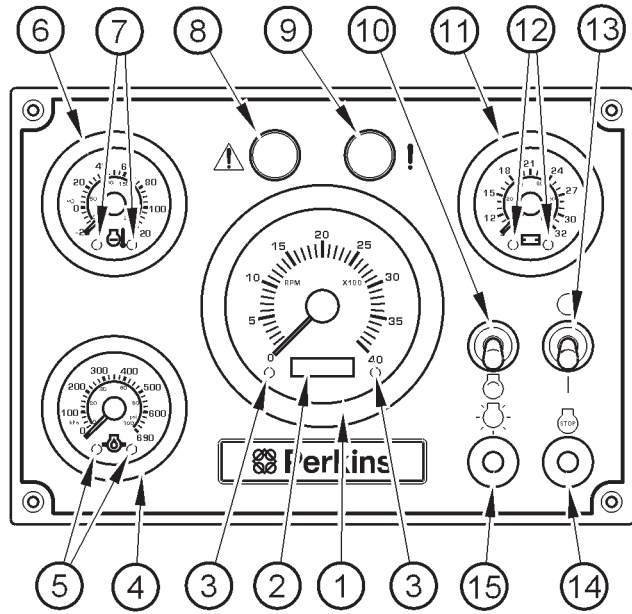
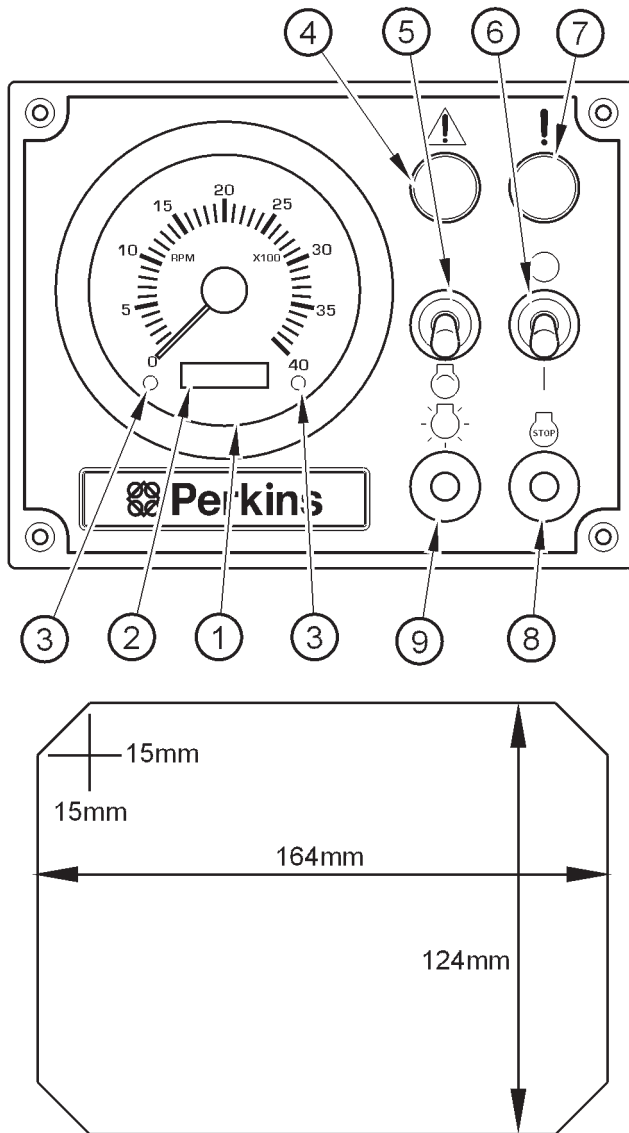

Figure 4

The cutout dimensions are shown below the panel illustration.



**Auxiliary panel**

- 12 or 24 volt operation from same panel.
- IP 65 rated from front facia, switches/gauges IP67 rated.

The 'Auxiliary panel' shown in figure 5 is 180mm x 140mm and includes:-

1. Tachometer
2. Engine hours/fault code display
3. Warning light
4. Warning lamp
5. Engine crank
6. Keyswitch on/off
7. Diagnostic lamp
8. Engine stop switch
9. Panel illumination

The cutout dimensions are shown below the panel illustration.

**Figure 5**

**Mini Marine Power Display (MMPD) digital panel**

- Single engine support.
- Displays engine parameters and fault codes with audible alarm.
- 5 display screens.
- High resolution display 320 X 240 DPI.
- Transflective screen improves readability by reflecting more or less light conditions as ambient light changes.
- Display brightness fully adjustable.
- Operates on 12 or 24 V systems.
- Supports several languages - English, German, French, Dutch, Portuguese, Norwegian and Italian.
- IP 67 rated.

The 'Digital panel' shown in Figure 6 is 150mm x 103mm and includes:-

1. Display:
2. Screen illumination
3. Alarm mute
4. Scroll forward button
5. Scroll back button

The cutout dimensions are shown below the panel illustration.

**Keyswitch panel**

The 'Keyswitch panel', used with the digital panel, is shown in figure 7 and is 110mm x 90mm and includes:-

1. Engine crank
2. Warning lamp
3. Diagnostic lamp
4. Engine stop switch
5. Keyswitch on/off

The cutout dimensions are shown below the panel illustration.

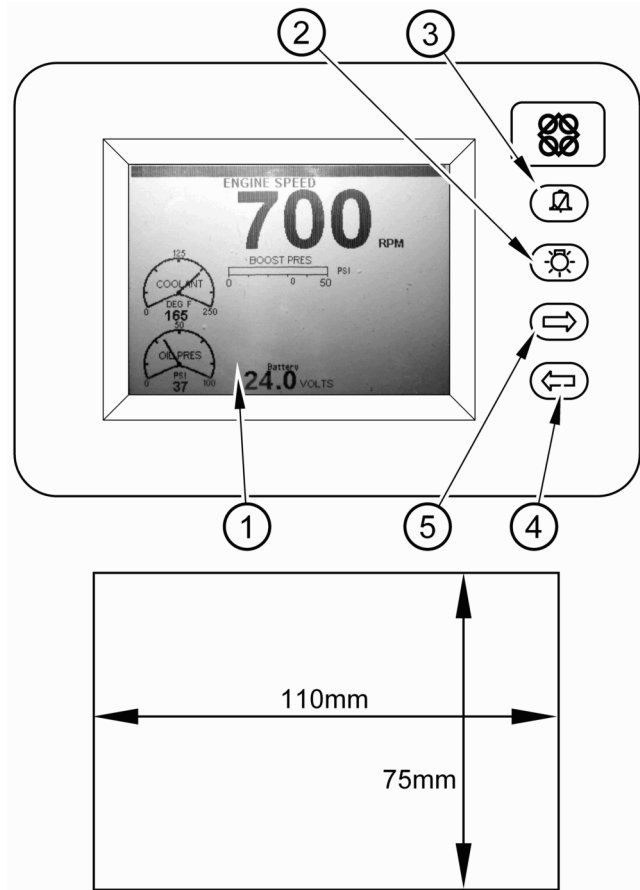

Figure 6

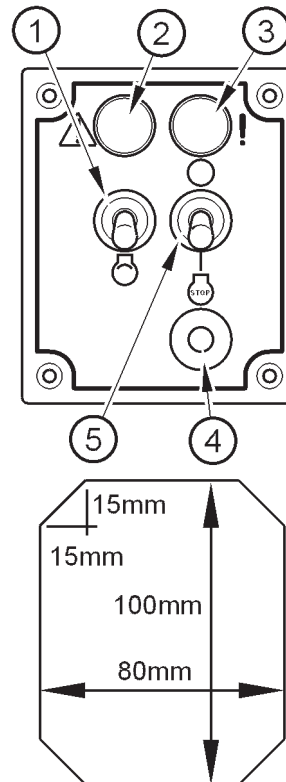

Figure 7

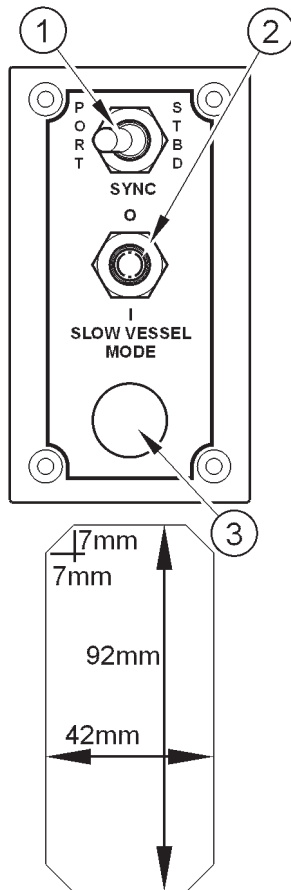

Figure 8

### Throttle synchronization / slow vessel mode panel

The function of the synchronization switch, figure 8, designates one of the throttles in a dual engine installation as the master throttle. When the switch (1) is activated each engine will respond to this master throttle.

One parameter must be configured in EST prior to using a secondary throttle position sensor. In the configuration screen, Secondary Throttle Enable Status defaults to “Disabled” and must be set to “Enabled”. If the “Number of Synchronized Engines Configuration” parameter is programmed to more than one engine, this parameter is automatically set to “Enabled”.

Engine response to the synchronization switch	
Position of the switch	Engine response
Starboard	Both engines respond to the starboard throttle
None	Each engine responds to a separate throttle
Port	Both engines respond to the port throttle

**The slow vessel mode (2)** reduces the low idle of the engine to 600rpm. This feature allows the customer to operate the vessel at slow speeds with all engines in gear for manoeuvring. Slow Vessel Mode cannot be engaged during the first 15 seconds after the engine has started or while the engine is in cold mode. When slow vessel mode is engaged, the desired engine speed will ramp down to the appropriate speed at a fixed rate. Slow vessel mode can be exited at any time. When slow vessel mode is disengaged, the desired engine speed will ramp up to the appropriate speed at a fixed rate.

Item (3) is a spare orifice for customers use.

**Possible panel configurations.**

A variety of panels may be run simultaneously, in any of the combinations as shown in figure 9.

1. Power supply.
2. Cable or electronic throttle and gearbox control options.
3. Main panel.
4. Auxiliary panel.
5. Mini Marine Power Display (MMPD) digital panel.
6. Keyswitch panel.

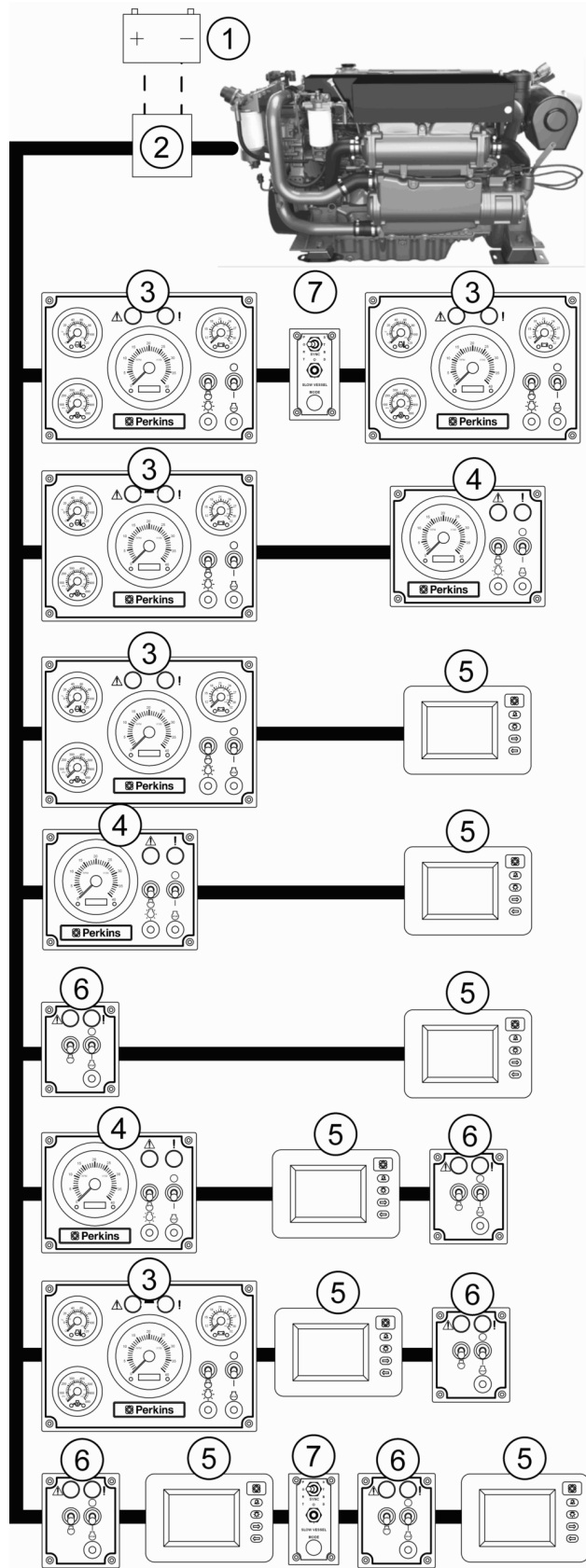
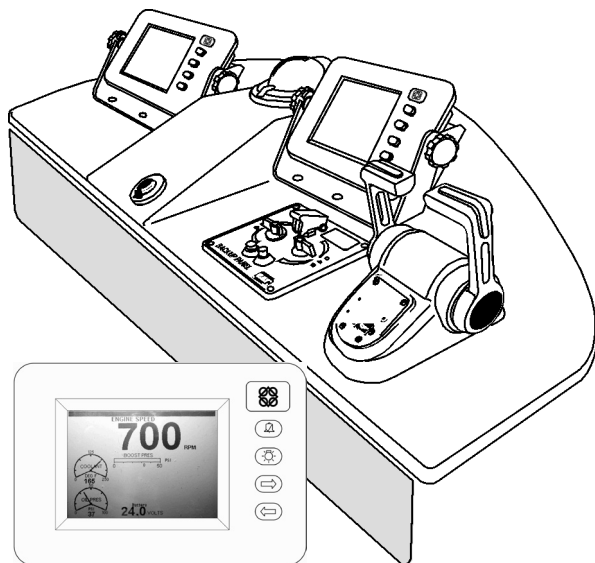

Figure 9





### Mini Marine Power Display (MMPD) instructions

The Mini Marine Power Display (MMPD) provides current engine and transmission operating data. The screen can be customized to display various engine parameters.

#### Information screens

There are two information screens available, the System Information screen and the Control System Information screen (figure 10). Pressing the button labelled **Menu** will display the System Information screen or the control system Information screen.

The System Information screen is the first screen displayed by default, however the MMPD will retain which information screen was displayed last until a power-off/reset.

#### System information screen

The System Information screen will display the current User Name, Software Version, ROM Bootloader Software Version, Unit Serial Number, Unit Location, Engine Location, Display Units, and Vessel Speed Units.

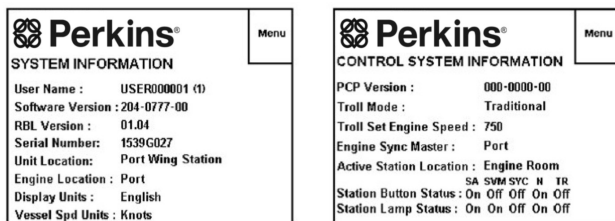

Figure 10

Pressing the button labelled **Menu** will display the System Information menu screen. On this screen, the button function is re-defined as shown on the right side of the screen, see figure 11. If a diagnostic code is active and the diagnostic code window is on screen, the button actions return to their normal definitions.

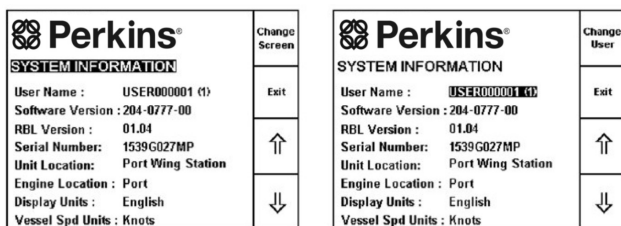

Figure 11

Pressing the up or down arrow button will cause the top menu item (labelled Change Screen) to scroll through the items to be changed (Change Screen, Change User, Change Unit Location, Change Display Units, and Change Vessel Speed Units) and cause the selected data to be displayed in reverse video.

Pressing the alarm button will cause the specified parameter to scroll through each available value (i.e. Change Vessel Speed would scroll through Knots, MPH, and KPH). Pressing the button labelled **Exit** will return the display to the System Information screen and save any changed data to non-volatile memory.

### Change screen

Pressing the alarm button will cause the Control System Information screen to be displayed. This option is only available if the MMPD has detected a Powertrain Control Processor (PCP) on the CAN data link.

### Change user

Pressing the alarm button will cause the displayed User Name text to scroll through the available user names.

### Change unit location

Pressing the alarm button will cause the displayed Unit Location text to scroll through the available location selections.

The vessel locations that are available are: Bridge, Port Wing, Starboard Wing, Tower, Engine Room, Aft Station, Fly Bridge, and Bow Station.

### Change display units

Pressing the alarm button will cause the displayed Display Units text to scroll through the available units selections (English and Metric).

### Change vessel speed units

Pressing the alarm button will cause the displayed Vessel Speed Units text to scroll through the available units selections (Knots, MPH, and KPH).

### Change system information screen

The Control System Information screen will only be displayed if a Powertrain Control Processor (PCP) is detected on the data link. This screen will display the PCP software part number, Troll Mode, Troll Set, Engine Speed, Engine Sync Master, Active Station Location, active Station Button Status, and Active Station Lamp Status. Pressing the button labelled **Menu** will display the screen shown in figure 12. On this screen the button functions are re-defined as shown on the right side of the screen. However, in the presence of a diagnostic code window button actions return to their normal definitions. Pressing the up or down arrows will cause the top menu item (labelled Change Screen) to scroll through the items to be modified (Change Screen, Change Troll Mode, Change Set Speed, Change Sync Master, and Change Station Location) and cause the selected data to be displayed in reverse video. Pressing the alarm button will cause the specified parameter to scroll through each available value. Pressing the button labelled **Exit** will return the display to the Control System Information screen and transmit any changed data items to the PCP.

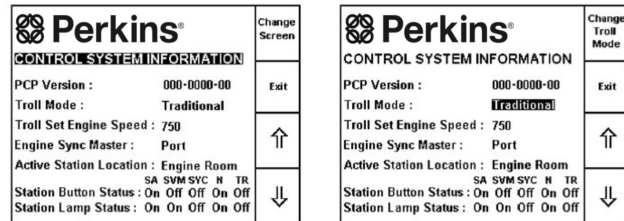

Figure 12

 <b>Perkins®</b> <b>CONTROL SYSTEM INFORMATION</b>		Save
PCP Version :	000-0000-00	+
Troll Mode :	Traditional	-
Troll Set Engine Speed :	750	
Engine Sync Master :	Port	
Active Station Location :	Engine Room	
Station Button Status :	SA SVM SYNC H TR On Off Off On Off	Cancel
Station Lamp Status :	On On Off On Off	

Figure 13

**Change screen**

Pressing the alarm button will cause the System Information screen to be displayed.

**Change troll mode**

Pressing the alarm button will cause the displayed Troll Mode to scroll through the available troll modes (Traditional and Intelli-Troll).

**Change troll speed**

Selecting Change Troll Set Speed (as figure 13) will display the following screen. Pressing + will increase the set speed by 1 rpm and pressing – will decrease the set speed by 1 rpm. Pressing Save will cause the MMPD to send the data to the PCP (and exit the screen), and pressing Cancel will cause the MMPD to exit the screen without sending any data to the PCP.

**Change engine sync master**

Pressing the alarm button will cause the displayed Engine Sync Master to scroll through the available sync master selections (PORT and STBD).

**Active station location**

Displays the Active Station Location (Bridge, Port Wing, Starboard Wing, Tower, Engine Room, Aft Station, Fly Bridge, and Bow Station). If the PCP reports that there is no active station, then the MMPD will display NONE in the Active Station Location field.

**Button status indicator**

The Station Button Status indicators display the button status as read by the active control station.

- SA – Activate Station Button Status
- SVM – Slow Vessel Mode Button Status
- SYNC – Engine Synchronization Button Status
- N – Idle (Neutral) Lockout Button Status
- TR – Trolling Mode Button Status

**Lamp status indicator**

The Station Lamp Status indicators display the commanded lamp status from the active control station.

- SA – Activate Station Lamp Status
- SVM – Slow Vessel Mode Lamp Status
- SYNC – Engine Synchronization Lamp Status
- N – Idle (Neutral) Lockout Lamp Status
- TR – Trolling Mode Lamp Status

**Vessel status bar**

The status indicators are shown across the top of the screen in reverse video and are only available on parameter screens, except for the diagnostic icon, which is shown on all screens.

**Status items (figure 14)**

1. Active diagnostic status of active station location.
2. Slow Vessel Mode (SVM) status.
3. Gear position
4. Troll mode status.
5. Engine synchronization status.

The Diagnostic icon overrides the Active Station Location when there is an active diagnostic condition.

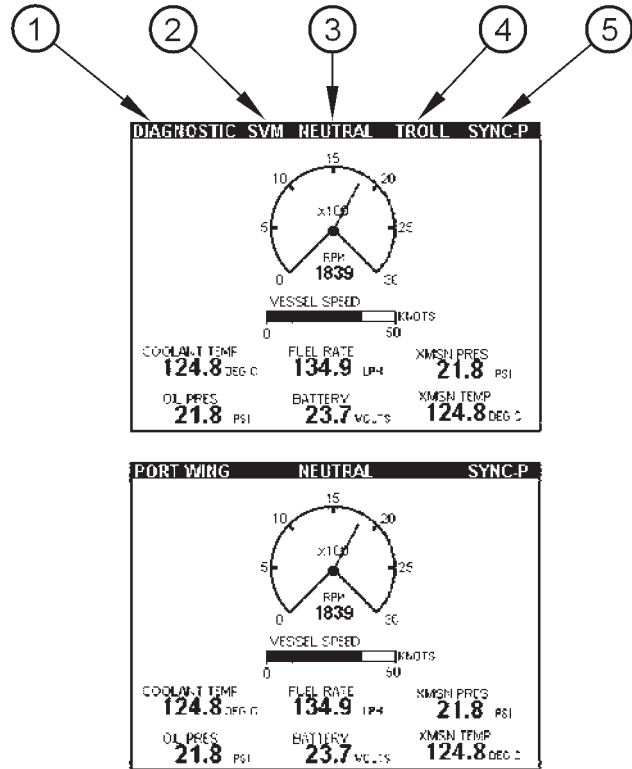

Figure 14

Parameter	Status	Display Text
Slow Vessel Mode (SVM)	SVM active SVM inactive	SVM No text displayed
Gear position	Forward Neutral Reverse Gear Lockout Active	AHEAD NEUTRAL ASTERN Gear L/O
Troll Mode	Troll active Troll inactive	TROLL No text displayed
Engine sync mode	Synchronized PORT Synchronized STBD PORT Master Sync cruise active STBD Master Sync cruise active Sync not active	SYNC-P SYNC-S CRUISE-P CRUISE-S No text displayed
Active station*	bridge PORT Wing STBD Wing Tower Engine room Aft station Fly bridge Bow station	BRIDGE PORT WING STBD WING TOWER ENG ROOM AFT STATION FLY BRIDGE BOW STATION

\* If there is an active diagnostic, the word DIAGNOSTIC will be displayed in place of the active station location.

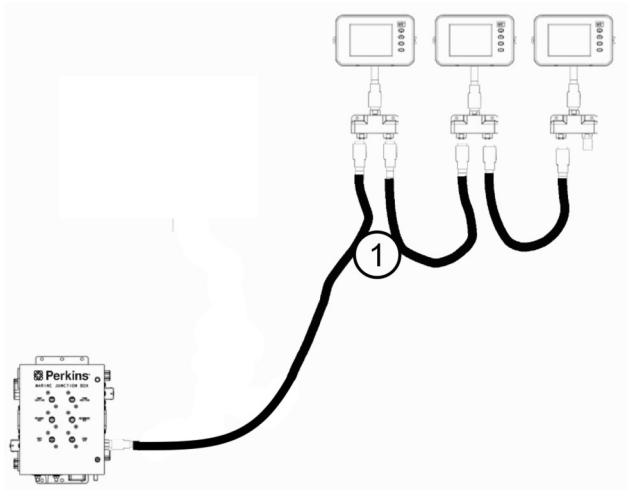

Figure 15

**Cables required**

**Where Used:** Connects the PCP and MMPD displays into the J1939 data link.

The J1939 data link (item 1 figure 15) can not exceed 40 meters (131ft.).

**Requires:**

MMPD drop cable

Tee to Tee cable

6-pin Tee

Termination resistor

**Termination resistor (figure 16)**

Used to terminate the ends of a data link run. Two termination resistors required

**Tee connector (figure 17)**

Used to connect tee to tee cables.

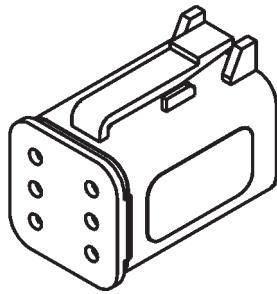

Figure 16

**CAN Data Link**

SAE J1939-15: Unshielded twisted pair.

The CAN network operates at 250 Kb/sec, it follows J1939-15 protocol.

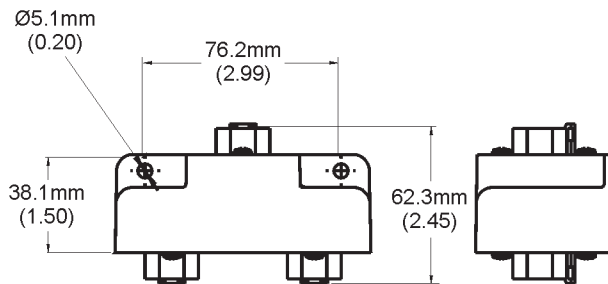
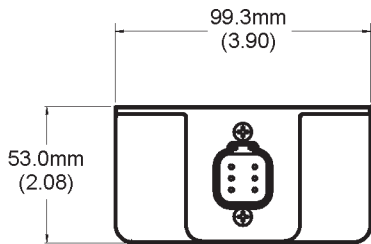

Figure 17

	J1939-15
Maximum Drops (nodes)	10
Maximum Cable Stub Length	3M
Maximum Cable Stub Length for service connector	2.66M
Maximum Bus Length	40M
Shielded Cable	NO

### For engines without an MJB (Marine Junction Box)

The customer connect harness (figure 18) can be used as a connection point for the various control panel options for both single engine applications and twin engine applications and is intended as a direct replacement for the MJB whilst maintaining the same functionality.

Figure 19 shows the main components.

1. Engine interface (ECM).
2. Twin engine.
3. Throttle synchronisation and slow vessel mode.
4. Key switch.
5. Throttle.
6. J1939.
7. Fuse (ignition).
8. Fuse (ECM and battery).

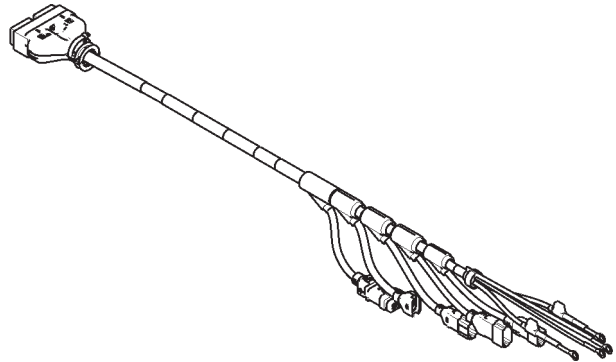

Figure 18

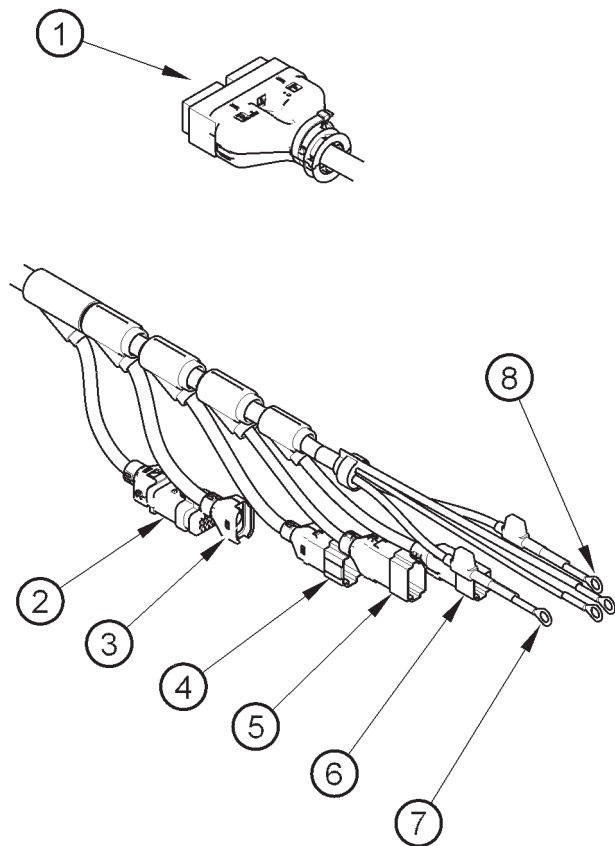
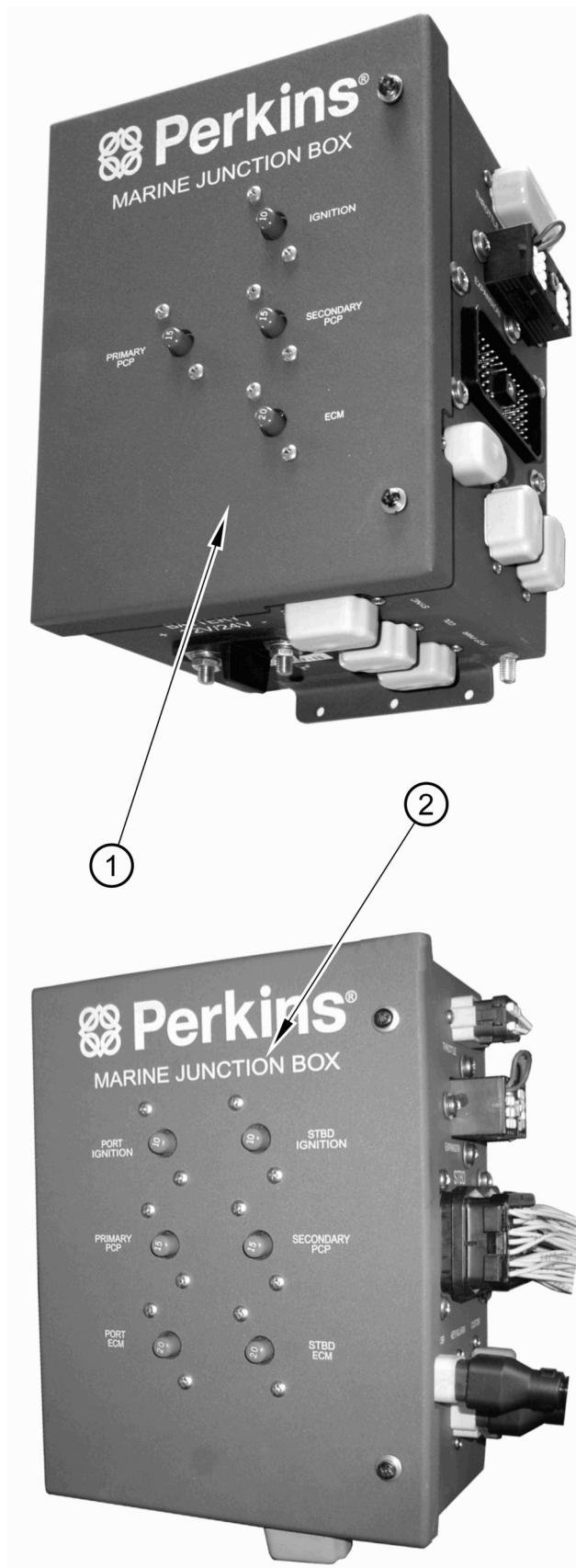

Figure 19



**For engines fitted with the Marine Junction Box (MJB)**

- Provides circuit protection for the ECM and other components connected to the on board monitoring and control systems.
- Stand alone junction box for any marine application.
- Used with various lengths of wiring harness for easier installation.
- Available for single (figure 20 item 1) or twin (figure 20 item 2) engine installations.

Inside the twin engine installation junction box, there are two separate wiring sections, one for the port system and a second for the starboard system. These sections provide the interconnection points for engine power and vessel control and monitoring. The Marine Junction Box also provides circuit protection for the ECM, keyswitch, and the other components connected to the vessel control system.

**Figure 20**

**Single engine MJB features and mounting details**

1. Breakers.
2. Throttle.
3. Expansion.
4. ECM.
5. J1939.
6. Key/alarm.
7. Custom.
8. Throttle synchronization panel.
9. PDL connector.
10. Power for the power train control processor (not used).
11. Connection for battery + battery.
12. Connection for battery - battery.

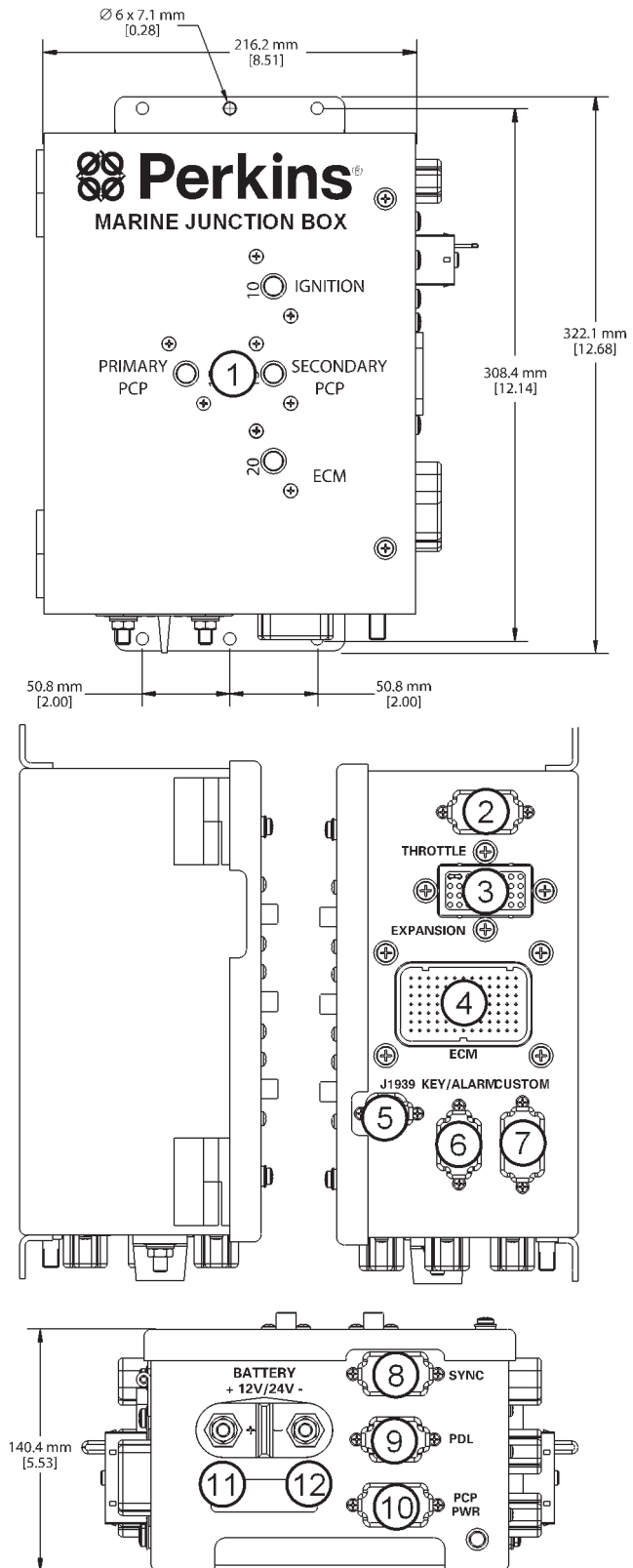
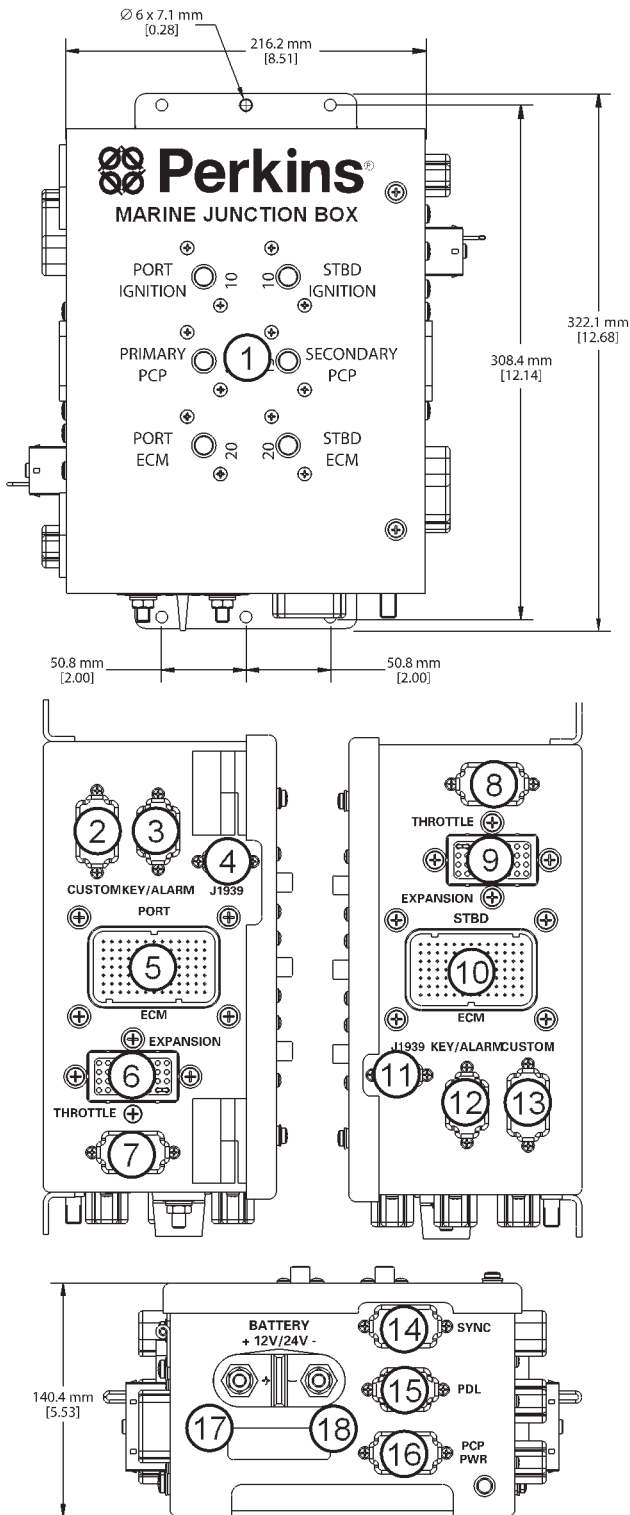

Figure 21





**Twin engine MJB features and mounting details**

1. Breakers.
2. Custom (port side).
3. Key/alarm (port side).
4. J1939 (port side).
5. ECM (port side).
6. Expansion (port side).
7. Throttle (port side).
8. Throttle (starboard side).
9. Expansion (starboard side).
10. ECM (starboard side).
11. J1939 (starboard side).
12. Key/alarm (starboard side).
13. Custom (starboard side).
14. Throttle synchronization panel
15. PDL connector.
16. Power for the power train control processor (not used).
17. Connection for battery + battery.
18. Connection for battery - battery.

Figure 22

**Power connections**

1. Marine junction box.
2. Battery reverse isolator.
3. Batteries
4. Minus battery bus bar.

Cable length*	4 Stations		8 Stations	
	12 volt	24 volt	12 volt	24 volt
5ft.(1.52m)	10 AWG	12AWG	6AWG	10 AWG
10ft (3.05m)	10 AWG	12 AWG	6 AWG	10 AWG
15ft (4.57m)	8 AWG	10 AWG	4 AWG	8 AWG
25ft (7.62m)	6 AWG	8 AWG	2 AWG	6 AWG
30ft (9.14m)	4 AWG	8 AWG	1 AWG	4 AWG

\*Refer to ABYC rules E-11 for AC & DC electrical systems on boats for more details.

**Note:** Perkins recommends installing two +battery and two -battery cables from the reverse isolator to the MJB and from the reverse isolator to the batteries.

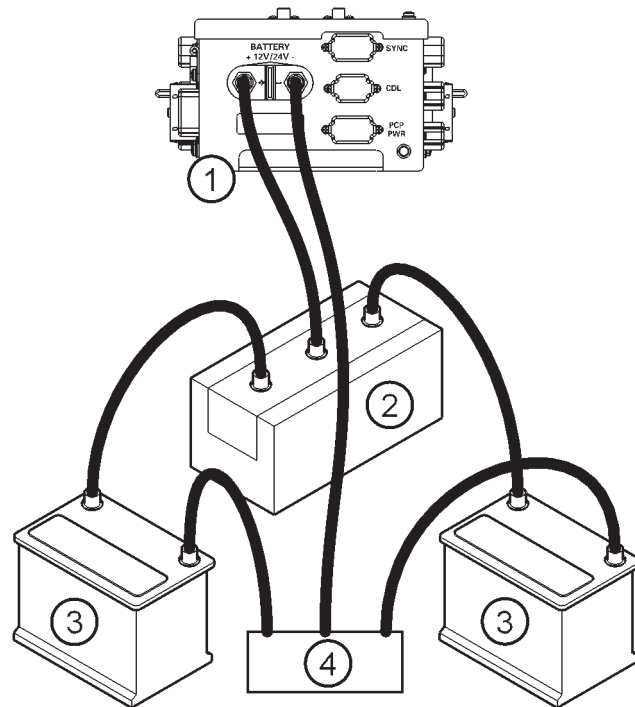

Figure 23

**Current requirements 12 or 24 vdc system**

The typical current draw for the MSCS with a twin engine installation with 4 control stations is 30 amps . The current draw for a twin engine installation with 8 control stations is 62 amps .

**ECM port or starboard interface connectors**

The MJB provides two interface connectors, one for the port engine and one for the starboard engine, which connect to the J61 customer connector. The connections are to interface with the ECM customer connector and provide battery power, switched inputs and data link signals to and from the ECM. The pin out is the same for both the port and starboard connectors .

**Grounding the battery negative**

It is recommended that the battery negative busbar should be grounded as close as possible to the battery, by a substantial connection to the bonding system within the boat. This will reduce the likelihood of interference between items of electrical and electronic equipment fitted to the boat.

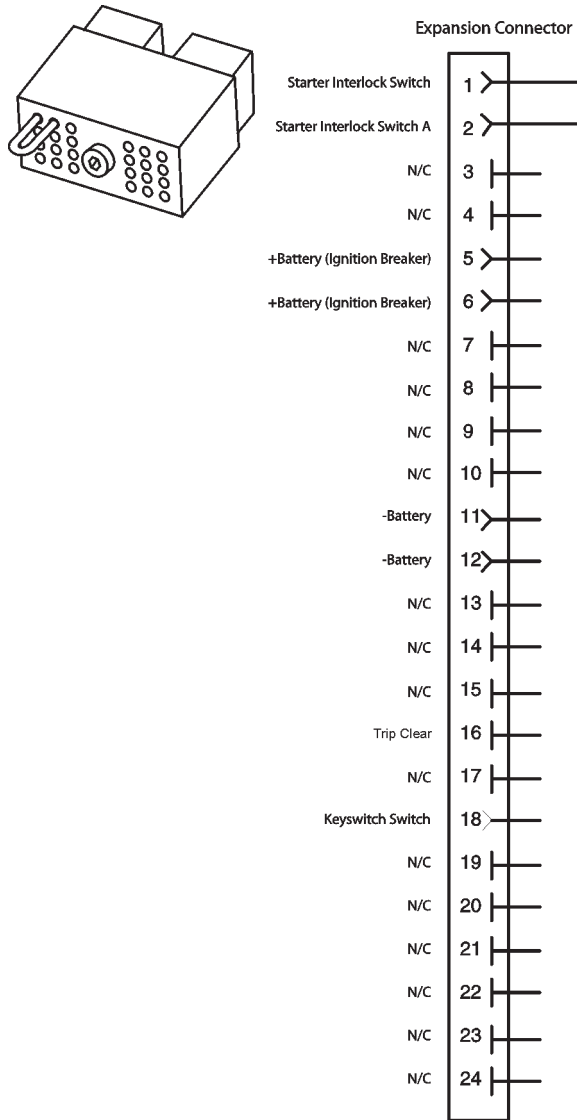

Figure 24

**Port or starboard expansion connectors**

The MJB provides two connectors, one for port and one for starboard, which will be used for future expansion. The pin out is the same for both the port and starboard connectors.

**Starter Interlock (Pins 1 & 2)**

The starter interlock provides a means of preventing the engine from starting through a switched circuit. The starter interlock may be wired through a neutral safety switch or other similar device. If no such device is installed, a jumper wire should be installed between expansion connector pins 1 and 2 as in figure 25.

Figure 26 shows a neutral safety switch (1), between the starter interlock pins 1 and 2.

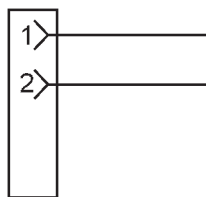

Figure 25

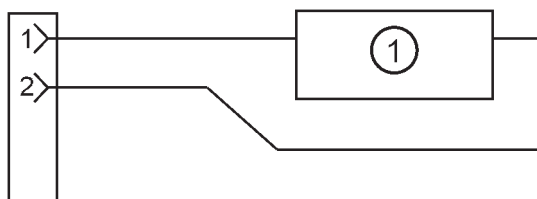

Figure 26

### Diagnostic lamp (Pin 2)

The diagnostic lamp, figure 27 alerts the operator to the presence of an active diagnostic code. A diagnostic code indicates a fault condition in the electronic control system. The operator uses this indication to help diagnose component failures in the electronic control system. The diagnostic flash codes should only be used to indicate the nature of the occurrence of a diagnostic condition. The flash codes should not be used to perform detailed troubleshooting. Troubleshooting should be performed using diagnostic codes that are displayed by using an electronic service tool.

When the ECM is energized (keyswitch turned ON), the warning lamp will turn on for five seconds. Then the lamp will turn off unless the ECM detects a warning condition.

1. Diagnostic lamp.
2. + Battery bus bar.

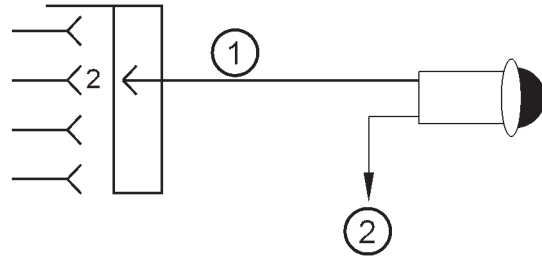

Figure 27

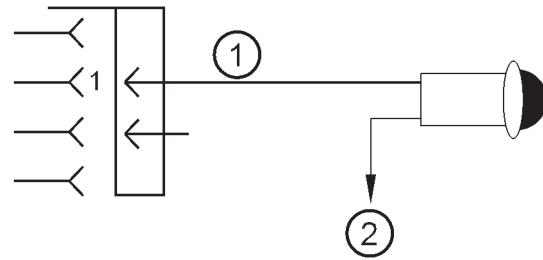

Figure 28

### Warning lamp (Pin 1)

The warning lamp figure 28 is used to alert the operator that an engine event has occurred.

A warning event code is active; the warning lamp is on solid.

A derate event code is active; the warning lamp will flash.

When the ECM is energized (keyswitch turned ON), the warning lamp will turn on for five seconds. Then the lamp will turn off unless the ECM detects a warning condition.

1. Warning lamp
2. + Battery bus bar.

### - Battery (Pin 11)

The minus battery input from the minus battery bus bar

### Keyswitch (Pin 12).

The switched battery input from the keyswitch, used to supply +battery to the components connected to the custom panel connector .

### Maintenance Clear switch (Pin 16)

The maintenance clear switch is required to reset the PM1 interval after maintenance has been performed on the engine.

## Cold start system

### Cold start data 12V and 24V

Temperature	Battery type with oil viscosity used					Start aid type	Min average cranking speed rev/min	Total battery voltage nominal
	20W	15W	10W	5W	0W			
5°C		F				Glow plugs	130	12V
-25°C				2 X B		Glow plugs	100	12V
-40°C					2 X E	Glow plugs and block heating	100	12V

### Battery performance

Battery Selection Tables By Engine-Results For Bare Engines based on min required speed of 100 rpm

Engine tested with 75% state of charge batteries and 1.7 mΩ cable resistance		
Starter information		Temperature & oil grade without glow plugs
Voltage	Starter type	-5°C 15W40
12V	Iskra AZF	950
24V	Iskra AZF	650

Commercial reference number	Perkins code	Battery minimum performance		
		BS EN 50342 <sup>(1)</sup>	SAE J537 (BCI) <sup>(2)</sup>	DIN 43539 <sup>(3)</sup>
643	A	440	640	400
647	B	510	700	465
069	D	340	540	300
655	E	570	760	490
621	F	860	900	505

(1) Voltage no less than 7,5V after 10 seconds, 6V after 90 seconds at -18°C (0°F) across each 12V battery.

(2) Voltage no less than 7,2V after 30 seconds at -18°C (0°F) across each 12V battery.

(3) Voltage no less than 6,0V after 150 seconds at -18°C (0°F) across each 12V battery.

### Battery to starter lead resistance

The resistance of the lead(s) used between the battery/batteries and the starter motor must not be more than 0.0017 ohms for 12V systems and 0.0034 ohms for 24V systems. More detailed information on types of battery is available from the Wimborne Marine Power Centre.

### Battery isolator switches

A switch should be fitted in the positive lead to the starter, as close to the battery as is convenient. The switch should be suitable for a momentary current of at least 950 Amps.

### Zinc Anode bonding system

**Caution:** *The engine may be damaged by electrolytic corrosion if the correct bonding procedure is not adopted. Please read the guidelines below carefully.*

Electrolytic corrosion within the engine cooling system and transmission can be much reduced or eliminated by bonding the engine to a Zinc anode which is used to protect through the hull metal fittings and other metal components that are in contact with sea water. The engine is fitted with a stud (figure 29 item 1) that may be used for this purpose and is identified by a label as shown in figure 30.

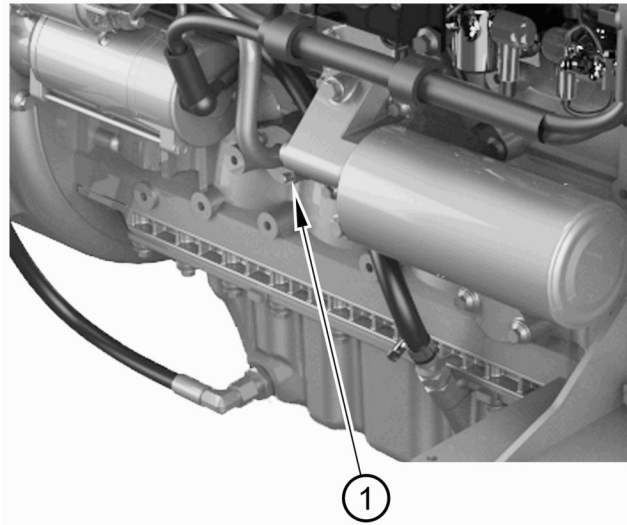

**Figure 29**

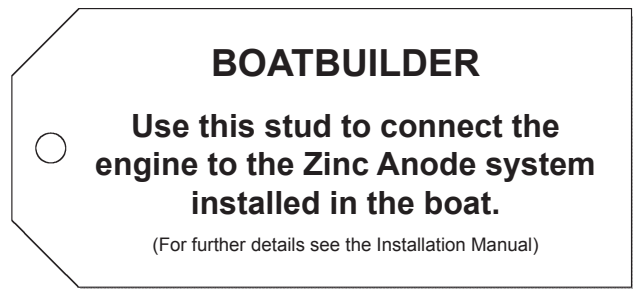

**Figure 30**

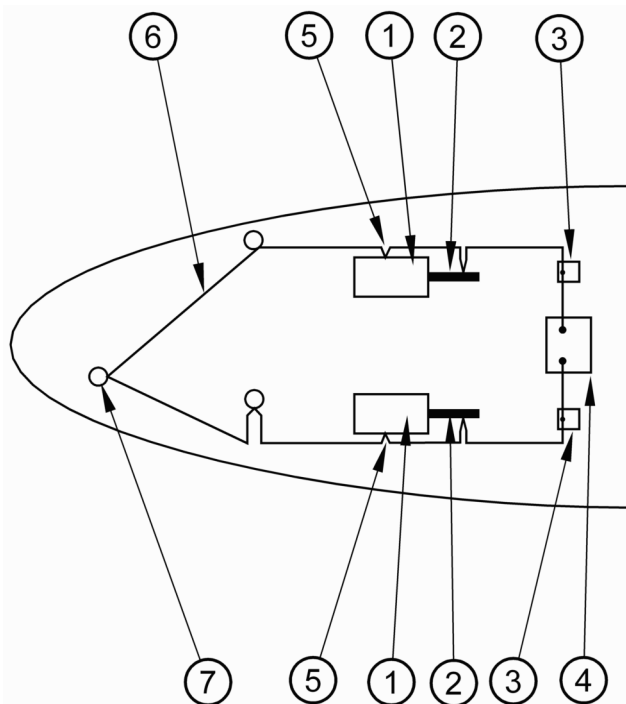

Figure 31

**Typical system in common use**

The bonding system in the boat should provide a low resistance connection between all metals in contact with sea water, together with a connection to a Zinc sacrificial anode which is fixed to the outside of the hull below sea level.

The bonding should consist of heavy stranded wire (not braiding or wire with fine strands). It is an advantage if the wire is tinned. Insulation is also an advantage and should preferably be green in colour. Although the current carried by the bonding system will not normally exceed 1 amp, the cable sizes should be generous as shown in the table below:

Length of run to Zinc Anode	Suggested cable size
Up to 30 feet	7 strand / 0.85mm (4mm <sup>2</sup> )
30 - 40 feet	7 strand / 1.04mm (6mm <sup>2</sup> )

As many of the connections may be splashed with sea water they should be soldered wherever possible and clamped elsewhere, with the joint protected from corrosion by neoprene paint, or a similar material, to exclude water.

Figure 31 shows the main components.

- (1) Engine.
- (2) Propeller shaft.
- (3) Sea cock.
- (4) Zinc anode.
- (5) Bonding stud.
- (6) Common bonding wire.
- (7) Through the hull metal fittings.

**Optional sensors**

- Throttle position.
- Fuel level.
- Transmission oil pressure.
- Transmission oil temperature.
- Exhaust gas temperature.
- Coolant level.
- Fuel temperature.
- Fuel supply pressure.





Wiring diagrams

ENGINE INTERFACE				
DT	CONNECTION TABLE	JB-C1	CLS-TERM	PLUG
CLR-GA	WIRE NAME	POS		
RD-14-GXL	101-JB51	1	180-9340	
		2	8T-8737	
BK-14-GXL	229-JB58	3	180-9340	
PK-18-GXL	M972-JB72	4	180-9340	
RD-14-GXL	101-JB52	5	180-9340	
BR-18-GXL	945-JB106	6	180-9340	
OR-18-GXL	944-JB104	7	180-9340	
RD-14-GXL	101-JB53	8	180-9340	
BK-14-GXL	229-JB61	9	180-9340	
BR-18-GXL	M971-JB71	10	180-9340	
BK-18-GXL	229-JB65	11	180-9340	
		12	8T-8737	
		13	8T-8737	
		14	8T-8737	
		15	8T-8737	
		16	8T-8737	
YL-18-GXL	K900-JB34	17	180-9340	
GN-18-GXL	K990-JB33	18	180-9340	
		19	8T-8737	
		20	8T-8737	
		21	8T-8737	
		22	8T-8737	
		23	8T-8737	
BU-18-GXL	F429-JB05	24	180-9340	
YL-18-GXL	F473-JB06	25	180-9340	
		26	8T-8737	
		27	8T-8737	
		28	8T-8737	
PK-18-GXL	391-JB04	29	180-9340	
BR-18-GXL	J906-JB69	30	180-9340	
		31	8T-8737	
		32	8T-8737	
		33	8T-8737	
BR-18-GXL	M973-JB53	34	180-9340	
YL-18-GXL	M974-JB70	35	180-9340	
PU-18-GXL	G966-JB03	36	180-9340	
PU-18-GXL	F425-JB117	37	180-9340	
GY-18-GXL	R819-JB50	38	180-9340	
		39	8T-8737	
		40	8T-8737	
BK-18-GXL	C214-JB121	41	180-9340	
BK-18-GXL	C214-JB121	42	180-9340	
		43	8T-8737	
		44	8T-8737	
		45	8T-8737	
		46	8T-8737	
		47	8T-8737	
		48	8T-8737	
		49	8T-8737	
		50	8T-8737	
		51	8T-8737	
		52	8T-8737	
		53	8T-8737	
		54	8T-8737	
		55	8T-8737	
		56	8T-8737	
		57	8T-8737	
		58	8T-8737	
		59	8T-8737	
		60	8T-8737	
		61	8T-8737	
		62	8T-8737	
		63	8T-8737	
		64	8T-8737	
		65	8T-8737	
		66	8T-8737	
		67	8T-8737	
		68	8T-8737	
		69	8T-8737	
		70	8T-8737	

ACCESSORY TABLE		
QTY	PART NAME	P/N
1	PLUG AS.-CONN	245-8024
2	ADAPTER-CONN	372-4389
1	RETAINER	372-4390

TWIN ENGINE				
AMP	CONNECTION TABLE	CLS-TERM	PLUG	PLUG
CLR-GA	WIRE NAME	POS		
OR-18-GXL	944-JB104	1	144-1636	
BR-18-GXL	945-JB106	2	144-1636	
GY-18-GXL	R819-JB50	3	144-1636	
PU-18-GXL	F425-JB114	4	144-1636	
BR-18-GXL	M971-JB71	5	144-1636	
PK-18-GXL	M972-JB111	6	144-1636	
BR-18-GXL	M973-JB112	7	144-1636	
YL-18-GXL	M974-JB113	8	144-1636	
		9	8T-8737	
		10	8T-8737	
		11	8T-8737	
		12	8T-8737	

ACCESSORY TABLE		
QTY	PART NAME	P/N
1	RECEPTACLE_AS	230-4010
1	WEDGE	3E-3383
1	BACKSHELL	311-8735

THROTTLE SYNC & SVM				
DT	CONNECTION TABLE	CLS-TERM	PLUG	PLUG
CLR-GA	WIRE NAME	POS		
YL-18-GXL	M974-JB113	1	180-9339	
BR-18-GXL	M973-JB53	2	180-9339	
YL-18-GXL	M974-JB70	3	180-9339	
GY-18-GXL	R819-JB74	4	180-9339	
BK-18-GXL	229-JB70	5	180-9339	
		6	8T-8737	
PK-18-GXL	M972-JB111	7	180-9339	
BR-18-GXL	M971-JB118	8	180-9339	
BR-18-GXL	M971-JB118	9	180-9339	
PK-18-GXL	M972-JB117	10	180-9339	
BR-18-GXL	M973-JB112	11	180-9339	
PU-18-GXL	F425-JB67	12	180-9339	

ACCESSORY TABLE		
QTY	PART NAME	P/N
1	RECEPTACLE_AS	190-7612
1	WEDGE	3E-5180
1	BACKSHELL	311-8748

KEY SWITCH				
DT	CONNECTION TABLE	CLS-TERM	PLUG	PLUG
CLR-GA	WIRE NAME	POS		
BR-18-GXL	J906-JB01	1	180-9339	
		2	8T-8737	
PU-18-GXL	G966-JB03	3	180-9339	
PK-18-GXL	391-JB04	4	180-9339	
BU-18-GXL	F429-JB05	5	180-9339	
YL-18-GXL	F473-JB06	6	180-9339	
RD-18-GXL	J05-JB08	8	180-9339	

ACCESSORY TABLE		
QTY	PART NAME	P/N
1	RECEPTACLE_AS	3E-3388
1	WEDGE	3E-3389
1	BACKSHELL	311-8747

THROTTLE				
DT	CONNECTION TABLE	CLS-TERM	PLUG	PLUG
CLR-GA	WIRE NAME	POS		
		1	8T-8737	
		2	8T-8737	
		3	8T-8737	
		4	8T-8737	
		5	8T-8737	
BK-18-GXL	229-J117	6	180-9339	
BR-18-GXL	J906-JB13	7	180-9339	
		8	8T-8737	
		9	8T-8737	
BR-18-GXL	M971-JB55	10	180-9339	
PK-18-GXL	M972-JB54	11	180-9339	
		12	180-9339	

ACCESSORY TABLE		
QTY	PART NAME	P/N
1	RECEPTACLE_AS	3E-5179
1	WEDGE	3E-5180
1	BACKSHELL	311-8748

J906				
DT	CONNECTION TABLE	CLS-TERM	PLUG	PLUG
CLR-GA	WIRE NAME	POS		
RD-18-GXL	J05-JB29	1	180-9339	
BK-18-GXL	229-JB30	2	180-9339	
BR-18-GXL	J906-JB31	3	180-9339	
		4	8T-8737	
GN-18-GXL	K990-JB33	5	180-9339	
YL-18-GXL	K900-JB34	6	180-9339	

ACCESSORY TABLE		
QTY	PART NAME	P/N
1	RECEPTACLE_AS	3E-3382
1	WEDGE	3E-3383
1	BACKSHELL	311-8746

FUSE (ECM & BATT)				
FUSE	CONNECTION TABLE	CLS-TERM	PLUG	PLUG
CLR-GA	WIRE NAME	POS		
RD-4	101-FUSE1	1		
RD-12	101-FUSE2	2		

ACCESSORY TABLE		
QTY	PART NAME	P/N
1	HOLDER-FUSE	304-5284
1	FUSE	113-8491

FUSE IGNITION				
FUSE	CONNECTION TABLE	CLS-TERM	PLUG	PLUG
CLR-GA	WIRE NAME	POS		
RD-4	105-FUSE1	1		
RD-12	105-FUSE2	2		

ACCESSORY TABLE		
QTY	PART NAME	P/N
1	HOLDER-FUSE	304-5284
1	FUSE	113-8491

MATING CONNECTOR OF TWIN ENGINE				
AMP	CONNECTION TABLE	CLS-TERM	PLUG	PLUG
CLR-GA	WIRE NAME	POS		
		1	8T-8737	
		2	8T-8737	
		3	8T-8737	
		4	8T-8737	
		5	8T-8737	
		6	8T-8737	
		7	8T-8737	
		8	8T-8737	
		9	8T-8737	
		10	8T-8737	
		11	8T-8737	
		12	8T-8737	

  

ACCESSORY TABLE		
QTY	PART NAME	P/N
1	PLUG AS-CONN	230-4009

MATING CONNECTOR OF THROTTLE SYNC & SVM				
DT	CONNECTION TABLE	CLS-TERM	PLUG	PLUG
CLR-GA	WIRE NAME	POS		
		1	8T-8737	
		2	8T-8737	
		3	8T-8737	
		4	8T-8737	
		5	8T-8737	
		6	8T-8737	
		7	8T-8737	
		8	8T-8737	
		9	8T-8737	
		10	8T-8737	
		11	8T-8737	
		12	8T-8737	

ACCESSORY TABLE		
QTY	PART NAME	P/N
1	PLUG AS-CONN	155-2253

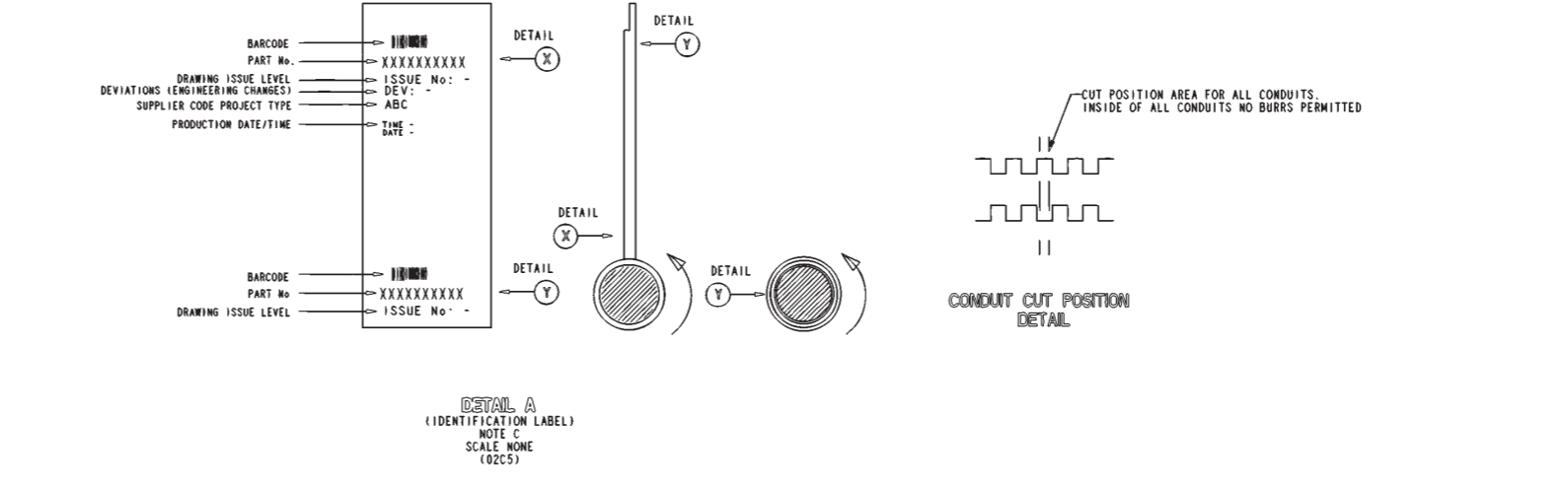
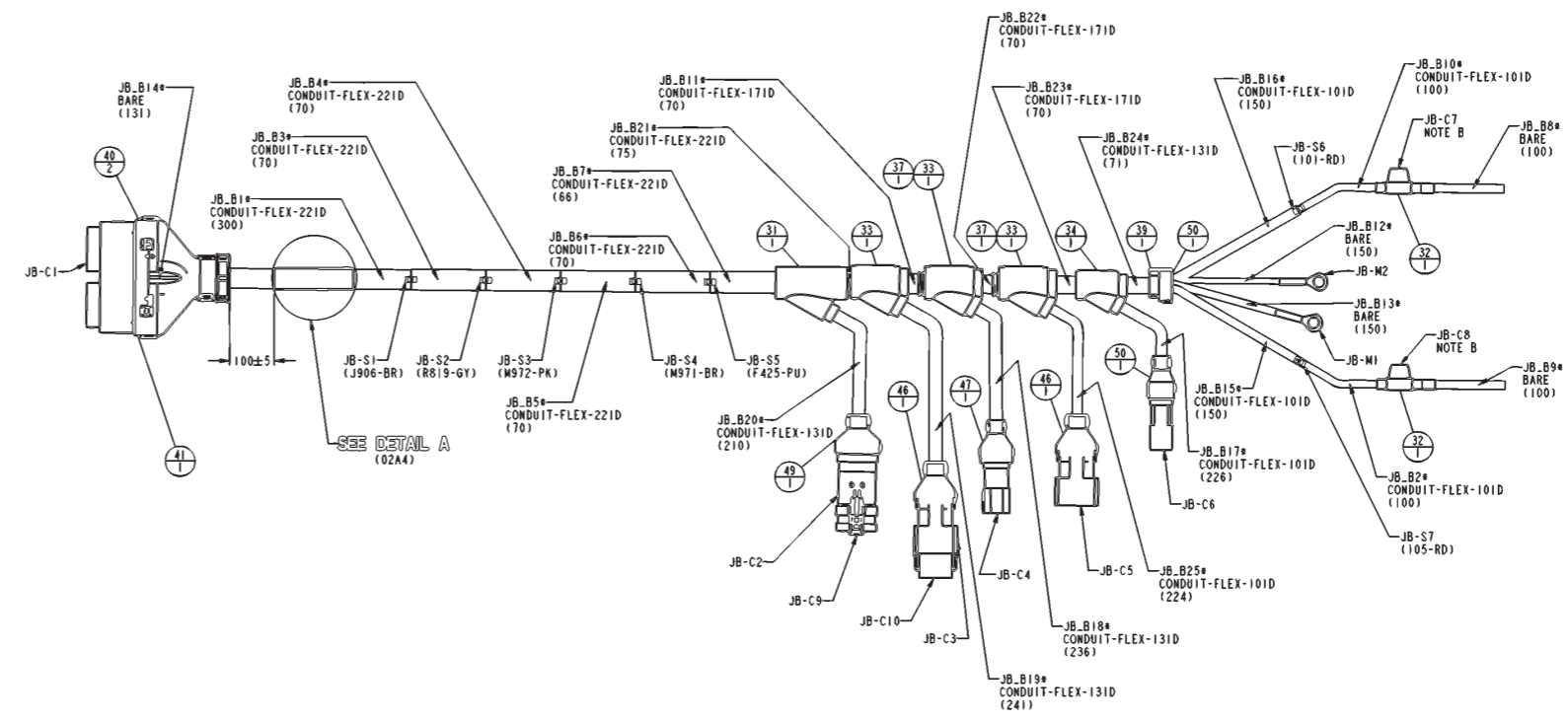

\*See the CD for PC compatible version of this diagram.

\*Engine wiring harness overview, without MJB

CIRCUIT DATA TABLE																			
			END #1					CIRCUIT - WIRE					END #2						
DRWG LOC	SIGNAL NAME	ID	CONNECTOR			TERM P/N	CIRCUIT ID	WIRE - NAME	GA	REF LENGTH	COLOR	WIRE P/N	TERM P/N	CONNECTOR			ID	SIGNAL NAME	DRWG LOC
			P/N	POS	TERM									TERM	POS	P/N			
2-D-1	UNSWITCHED_BATTERY_(+)	JB-C7	304-5284	1			101-FUSE1	4	100	RD	6V-2366			2	304-5284	JB-C7	UNSWITCHED_BATTERY_(+)	2-D-6	
2-D-2	SPLICE	JB-S6		1		SPLICE	101-FUSE2	12	200	RD	6A-3556			2	304-5284	JB-C7	UNSWITCHED_BATTERY_(+)	2-D-1	
2-D-2	SPLICE	JB-S6		2		SPLICE	101-JB51	14	1149	RD	339-5467	180-9340	1	245-8024	JB-C1	UNSWITCHED_BATTERY_(+)	2-D-6		
2-D-2	SPLICE	JB-S6		2		SPLICE	101-JB52	14	1149	RD	339-5467	180-9340	5	245-8024	JB-C1	UNSWITCHED_BATTERY_(+)	2-D-6		
2-D-2	SPLICE	JB-S6		2		SPLICE	101-JB53	14	1149	RD	339-5467	180-9340	8	245-8024	JB-C1	UNSWITCHED_BATTERY_(+)	2-D-6		
2-C-1	UNSWITCHED_BATTERY_(+)	JB-C8	304-5284	1			105-FUSE1	4	100	RD	6V-2366						UNSWITCHED_BATTERY_(+)	2-D-6	
2-D-2	SPLICE	JB-S7		1		SPLICE	105-FUSE2	12	200	RD	6A-3556			2	304-5284	JB-C8	KEY_SWITCH	2-C-1	
2-D-2	SPLICE	JB-S7		2		SPLICE	105-JB08	18	596	RD	339-5439	180-9339	8	3E-3388	JB-C4	KEY_SWITCH	2-C-3		
2-D-2	SPLICE	JB-S7		2		SPLICE	105-JB29	18	447	RD	339-5439	180-9339	1	3E-3382	JB-C6	KEY_SWITCH	2-C-2		
2-D-2	BATTERY_(-)	JB-M1		0		131-1506	229-J117	18	515	BK	339-5431	180-9339	6	3E-5179	JB-C5	BATTERY_(-)	2-C-3		
2-D-2	BATTERY_(-)	JB-M2		0		131-1506	229-JB07	18	596	BK	339-5431	180-9339	7	3E-3388	JB-C4	BATTERY_(-)	2-C-3		
2-D-2	BATTERY_(-)	JB-M1		0		131-1506	229-JB30	18	447	BK	339-5431	180-9339	2	3E-3382	JB-C6	BATTERY_(-)	2-C-2		
2-D-2	BATTERY_(-)	JB-M1		0		131-1506	229-JB58	14	1149	BK	339-5457	180-9340	3	245-8024	JB-C1	BATTERY_(-)	2-D-6		
2-D-2	BATTERY_(-)	JB-M1		0		131-1506	229-JB61	14	1149	BK	339-5457	180-9340	9	245-8024	JB-C1	BATTERY_(-)	2-D-6		
2-D-2	BATTERY_(-)	JB-M2		0		131-1506	229-JB65	18	1149	BK	339-5431	180-9340	11	245-8024	JB-C1	BATTERY_(-)	2-D-6		
2-D-2	BATTERY_(-)	JB-M2		0		131-1506	229-JB70	18	671	BK	339-5431	180-9339	5	190-7612	JB-C3	BATTERY_(-)	2-C-3		
2-C-3	REMOTE_START_/STOP	JB-C4	3E-3388	4	180-9339		391-JB04	18	1024	PK	339-5437	180-9340	29	245-8024	JB-C1	REMOTE_START_/STOP	2-D-6		
2-C-3	CAT_DATA_LINK_L_(+)	JB-C2	230-4010	1	144-1636		944-JB104	18	854	OR	339-5436	180-9340	7	245-8024	JB-C1	CAT_DATA_LINK_L_(+)	2-D-6		
2-C-3	CAT_DATA_LINK_L_(-)	JB-C2	230-4010	2	144-1636		945-JB106	18	854	BR	339-5432	180-9340	6	245-8024	JB-C1	CAT_DATA_LINK_L_(-)	2-D-6		
2-D-6	STARTER_INTERLOCK	JB-C1	245-8024	41	180-9340		C214-JB121	18	131	BK	339-5431	180-9340	42	245-8024	JB-C1	SMMS_RETURN	2-D-6		
2-D-4	SPLICE	JB-S5		2		SPLICE	F425-JB67	18	382	PU	339-5438	180-9339	12	190-7612	JB-C3	TROLLING_MODE	2-C-3		
2-D-4	SPLICE	JB-S5		2		SPLICE	F425-JB114	18	276	PU	339-5438	144-1636	4	230-4010	JB-C2	TROLLING_MODE	2-C-3		
2-D-4	SPLICE	JB-S5		1		SPLICE	F425-JB117	18	578	PU	339-5438	180-9340	37	245-8024	JB-C1	TROLLING_MODE	2-D-6		
2-C-3	INDICATOR_-_DIAGNOSTIC_(CUSTOM)	JB-C4	3E-3388	5	180-9339		F429-JB05	18	1024	BU	339-5433	180-9340	24	245-8024	JB-C1	INDICATOR_-_DIAGNOSTIC_(CUSTOM)	2-D-6		
2-C-3	TRANSMISSION_WARNING	JB-C4	3E-3388	6	180-9339		F473-JB06	18	1024	YL	339-5441	180-9340	25	245-8024	JB-C1	TRANSMISSION_WARNING	2-D-6		
2-C-3	REMOTE_SHUTDOWN	JB-C4	3E-3388	3	180-9339		G966-JB03	18	1024	PU	339-5438	180-9340	36	245-8024	JB-C1	REMOTE_SHUTDOWN	2-D-6		
2-D-5	SPLICE	JB-S1		2		SPLICE	J906-JB01	18	724	BR	339-5432	180-9339	1	3E-3388	JB-C4	KEY_SWITCH	2-C-3		
2-D-5	SPLICE	JB-S1		2		SPLICE	J906-JB13	18	782	BR	339-5432	180-9339	7	3E-5179	JB-C5	KEY_SWITCH	2-C-3		
2-D-5	SPLICE	JB-S1		2		SPLICE	J906-JB31	18	854	BR	339-5432	180-9339	3	3E-3382	JB-C6	KEY_SWITCH	2-C-2		
2-D-5	SPLICE	JB-S1		1		SPLICE	J906-JB69	18	300	BR	339-5432	180-9340	30	245-8024	JB-C1	KEY_SWITCH	2-D-6		
2-C-2	J1939_DATA_LINK_L_(+)	JB-C6	3E-3382	6	180-9339		K900-JB34	18	1154	YL	339-5441	180-9340	17	245-8024	JB-C1	J1939_DATA_LINK_L_(+)	2-D-6		
2-C-2	J1939_DATA_LINK_L_(-)	JB-C6	3E-3382	5	180-9339		K990-JB33	18	1154	GN	339-5434	180-9340	18	245-8024	JB-C1	J1939_DATA_LINK_L_(-)	2-D-6		
2-D-4	SPLICE	JB-S4		2		SPLICE	M971-JB55	18	573	BR	339-5432	180-9339	10	3E-5179	JB-C5	PRIMARY_THROTTLE_POSITION	2-C-3		
2-D-4	SPLICE	JB-S4		1		SPLICE	M971-JB71	18	509	BR	339-5432	180-9340	10	245-8024	JB-C1	PRIMARY_THROTTLE_POSITION	2-D-6		
2-C-3	PRIMARY_THROTTLE_POSITION	JB-C2	230-4010	5	144-1636		M971-JB110	18	527	BR	339-5432	180-9339	8	190-7612	JB-C3	PRIMARY_THROTTLE_POSITION	2-C-3		
2-D-4	SPLICE	JB-S4		2		SPLICE	M971-JB118	18	451	BR	339-5432	180-9339	9	190-7612	JB-C3	PRIMARY_THROTTLE_POSITION	2-C-3		
2-D-4	SPLICE	JB-S3		2		SPLICE	M972-JB54	18	643	PK	339-5437	180-9339	11	3E-5179	JB-C5	SECONDARY_THROTTLE_POSITION	2-C-3		
2-D-4	SPLICE	JB-S3		1		SPLICE	M972-JB72	18	439	PK	339-5437	180-9340	4	245-8024	JB-C1	SECONDARY_THROTTLE_POSITION	2-D-6		
2-C-3	SECONDARY_THROTTLE_POSITION	JB-C2	230-4010	6	144-1636		M972-JB111	18	527	PK	339-5437	180-9339	7	190-7612	JB-C3	SECONDARY_THROTTLE_POSITION	2-C-3		
2-D-4	SPLICE	JB-S3		2		SPLICE	M972-JB117	18	521	PK	339-5437	180-9339	10	190-7612	JB-C3	SECONDARY_THROTTLE_POSITION	2-C-3		
2-C-3	SYNCHRONIZE_IP_1	JB-C3	190-7612	2	180-9339		M973-JB53	18	960	BR	339-5432	180-9340	34	245-8024	JB-C1	SYNCHRONIZE_IP_1	2-D-6		
2-C-3	SYNCHRONIZE_IP_1	JB-C2	230-4010	7	144-1636		M973-JB112	18	527	BR	339-5432	180-9339	11	190-7612	JB-C3	SYNCHRONIZE_IP_1	2-C-3		
2-C-3	SYNCHRONIZE_IP_2	JB-C3	190-7612	3	180-9339		M974-JB70	18	960	YL	339-5441	180-9340	35	245-8024	JB-C1	SYNCHRONIZE_IP_2	2-D-6		
2-C-3	SYNCHRONIZE_IP_2	JB-C2	230-4010	8	144-1636		M974-JB113	18	527	YL	339-5441	180-9339	1	190-7612	JB-C3	SYNCHRONIZE_IP_2	2-C-3		
2-D-5	SPLICE	JB-S2		1		SPLICE	R819-JB50	18	370	GY	339-5435	180-9340	38	245-8024	JB-C1	SLOW_VESSEL_MODE	2-D-6		
2-D-5	SPLICE	JB-S2		2		SPLICE	R819-JB74	18	590	GY	339-5435	180-9339	4	190-7612	JB-C3	SLOW_VESSEL_MODE	2-C-3		
2-D-5	SPLICE	JB-S2		2		SPLICE	R819-JB81	18	484	GY	339-5435	144-1636	3	230-4010	JB-C2	SLOW_VESSEL_MODE	2-C-3		

WIRES IN THE FOLLOWING GROUPS SHALL BE TWISTED: ONE TWIST PER 25 MM

WIRE GROUP	WIRE NAME
JB_TW1	K900-JB34
JB_TW1	K990-JB33
JB_TW2	944-JB104
JB_TW2	945-JB106

BUNDLE TABLE				
BUNDLE NAME	COVERING	PART NO	LENGTH	BUNDLE DIAMETER
JB_B1*	CONDUIT-FLEX-22ID	292-2897	300	15.3
JB_B2*	CONDUIT-FLEX-10ID	292-2893	100	6.0
JB_B3*	CONDUIT-FLEX-22ID	292-2897	70	15.9
JB_B4*	CONDUIT-FLEX-22ID	292-2897	70	16.2
JB_B5*	CONDUIT-FLEX-22ID	292-2897	70	16.4
JB_B6*	CONDUIT-FLEX-22ID	292-2897	70	16.6
JB_B7*	CONDUIT-FLEX-22ID	292-2897	66	16.8
JB_B8*	CONDUIT-FLEX-22ID	292-2897	66	16.8
JB_B9*	BARE	-	100	4.4
JB_B10*	BARE	-	100	4.4
JB_B11*	BARE	-	100	4.4
JB_B12*	BARE	-	150	4.3
JB_B13*	BARE	-	150	5.5
JB_B14*	BARE	-	131	2.5
JB_B15*	CONDUIT-FLEX-10ID	292-2893	150	6.3
JB_B16*	CONDUIT-FLEX-10ID	292-2893	150	8.1
JB_B17*	CONDUIT-FLEX-10ID	292-2893	226	8.2
JB_B18*	CONDUIT-FLEX-13ID	292-2895	236	9.2
JB_B19*	CONDUIT-FLEX-13ID	292-2895	241	10.8
JB_B20*	CONDUIT-FLEX-13ID	292-2895	210	9.6
JB_B21*	CONDUIT-FLEX-22ID	292-2897	75	16.8
JB_B22*	CONDUIT-FLEX-17ID	292-2896	70	14.5
JB_B23*	CONDUIT-FLEX-17ID	292-2896	70	14.0
JB_B24*	CONDUIT-FLEX-13ID	292-2895	71	12.1
JB_B25*	CONDUIT-FLEX-10ID	292-2893	224	7.7

SPLICE TABLE						INSULATION		
REFDES	CLR-GA	WIRE	POS	P/N	LENGTH			
JB-S1	BR-18-GXL	J906-JB69	1	125-7875	50mm			
	BR-18-GXL	J906-JB01	2					
	BR-18-GXL	J906-JB13	2					
	BR-18-GXL	J906-JB31	2					
JB-S2	GY-18-GXL	R819-JB50	1	125-7874	50mm			
	GY-18-GXL	R819-JB74	2					
	GY-18-GXL	R819-JB81	2					
JB-S3	PK-18-GXL	M972-JB72	1	125-7874	50mm			
	PK-18-GXL	M972-JB117	2					
	PK-18-GXL	M972-JB54	2					
JB-S4	BR-18-GXL	M971-JB71	1	125-7874	50mm			
	BR-18-GXL	M971-JB118	2					
	BR-18-GXL	M971-JB55	2					
JB-S5	PU-18-GXL	F425-JB117	1	125-7874	50mm			
	PU-18-GXL	F425-JB67	2					
	PU-18-GXL	F425-JB114	2					
JB-S6	RD-12	101-FUSE2	1	125-7874	50mm			
	RD-14-GXL	101-JB51	2					

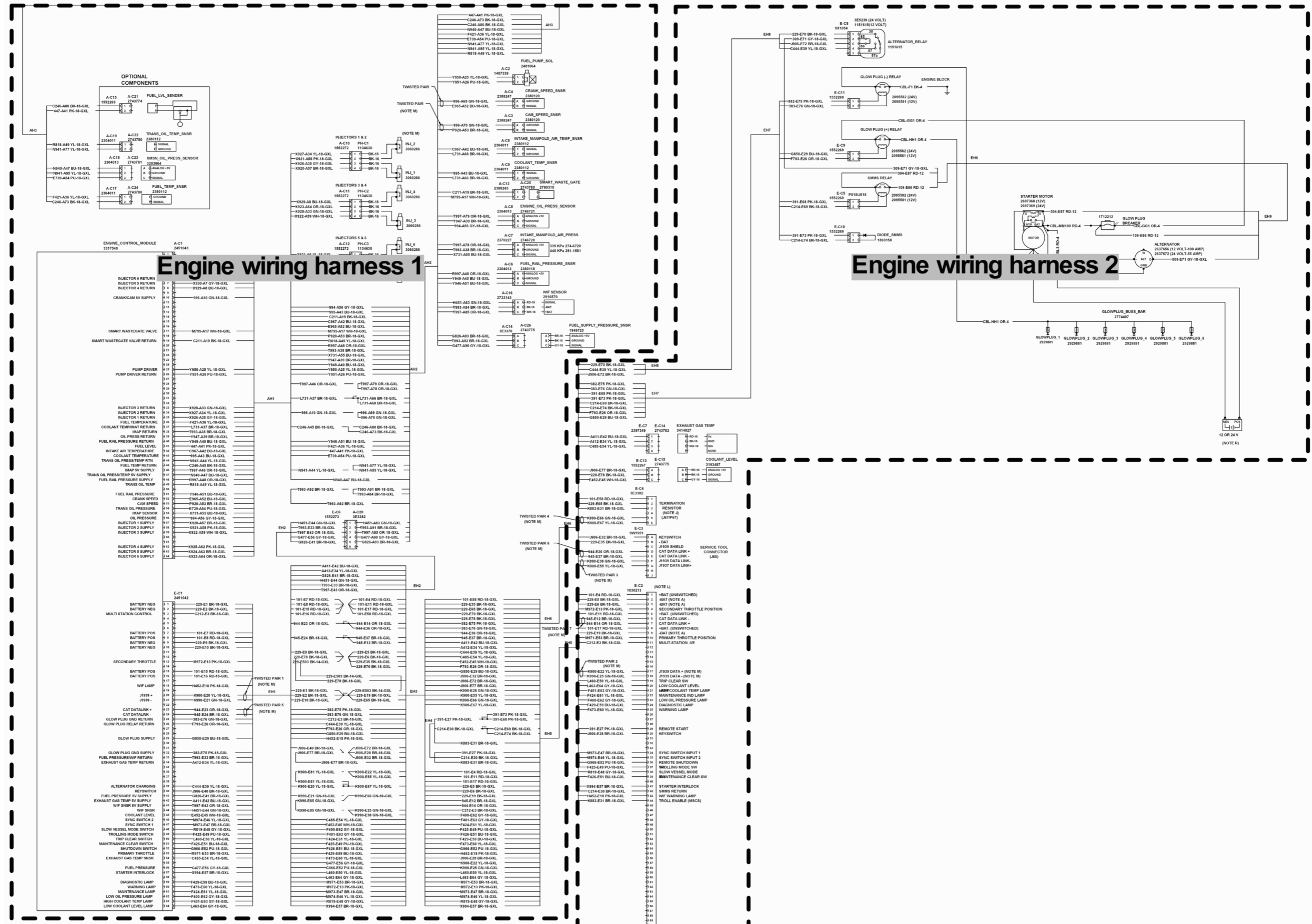

\*See the CD for PC compatible version of this diagram.

\*Engine wiring harness overview

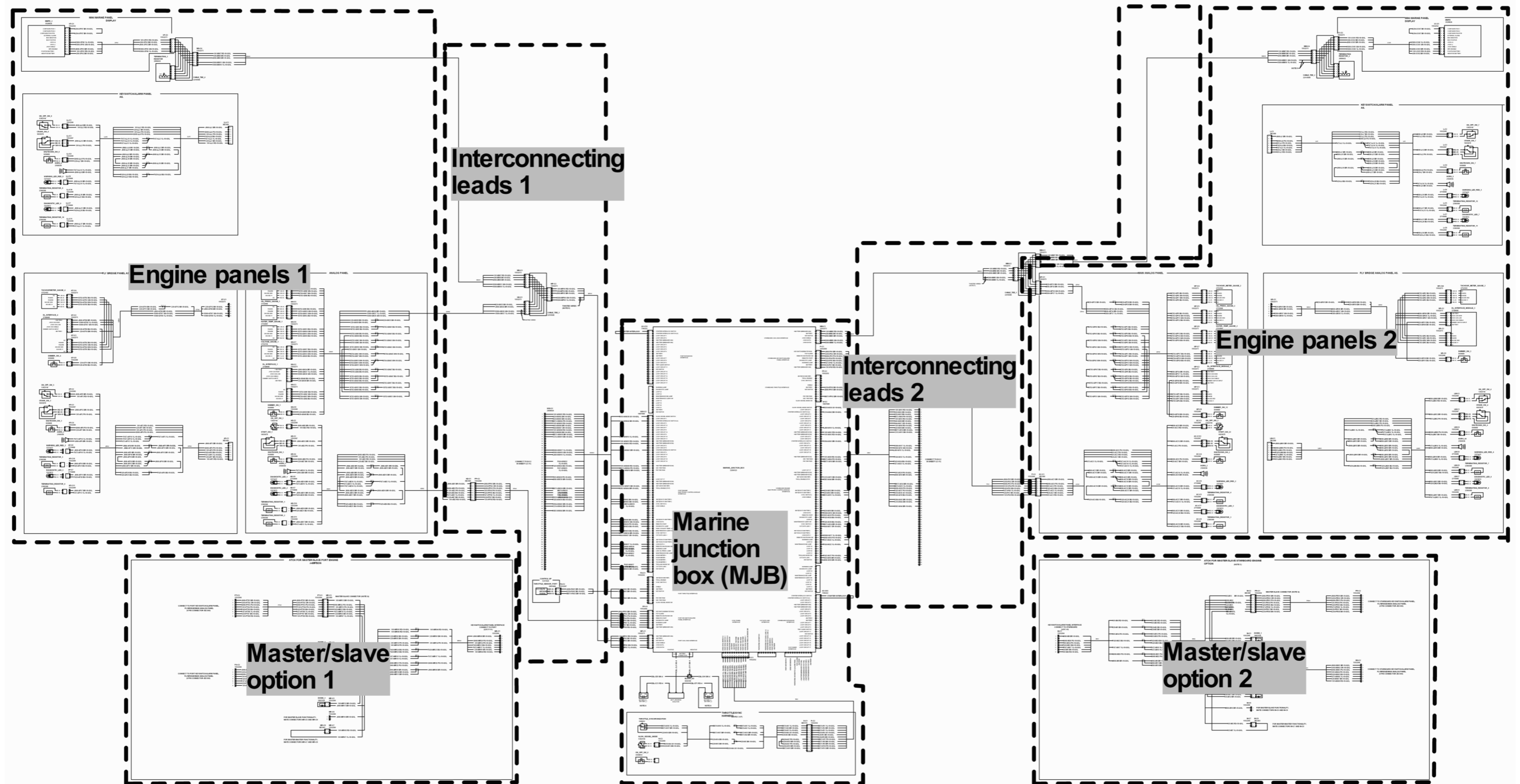

\*See the CD for PC compatible version of this diagram.

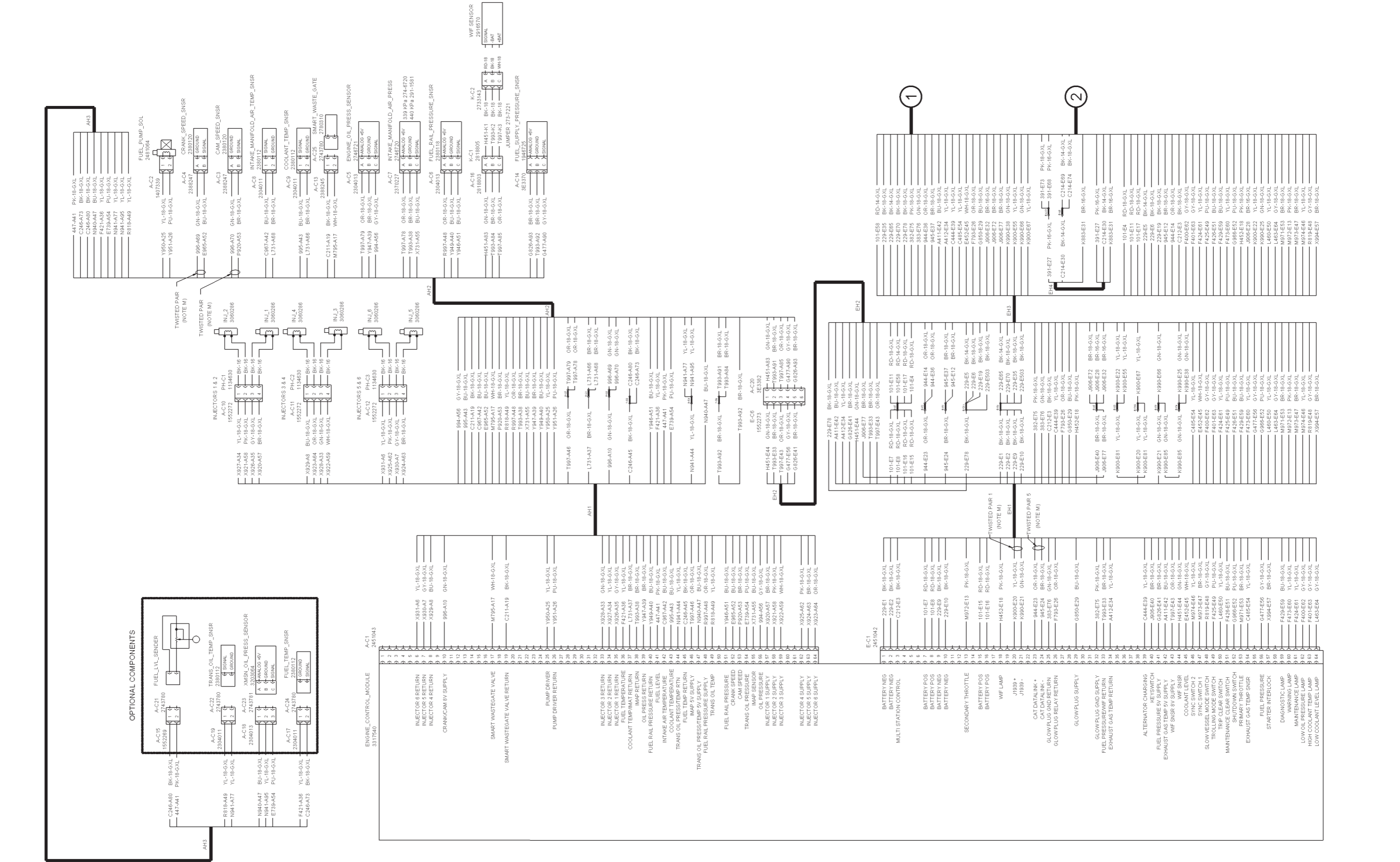

\*See the CD for PC compatible version of this diagram.

\*Engine wiring harness 1

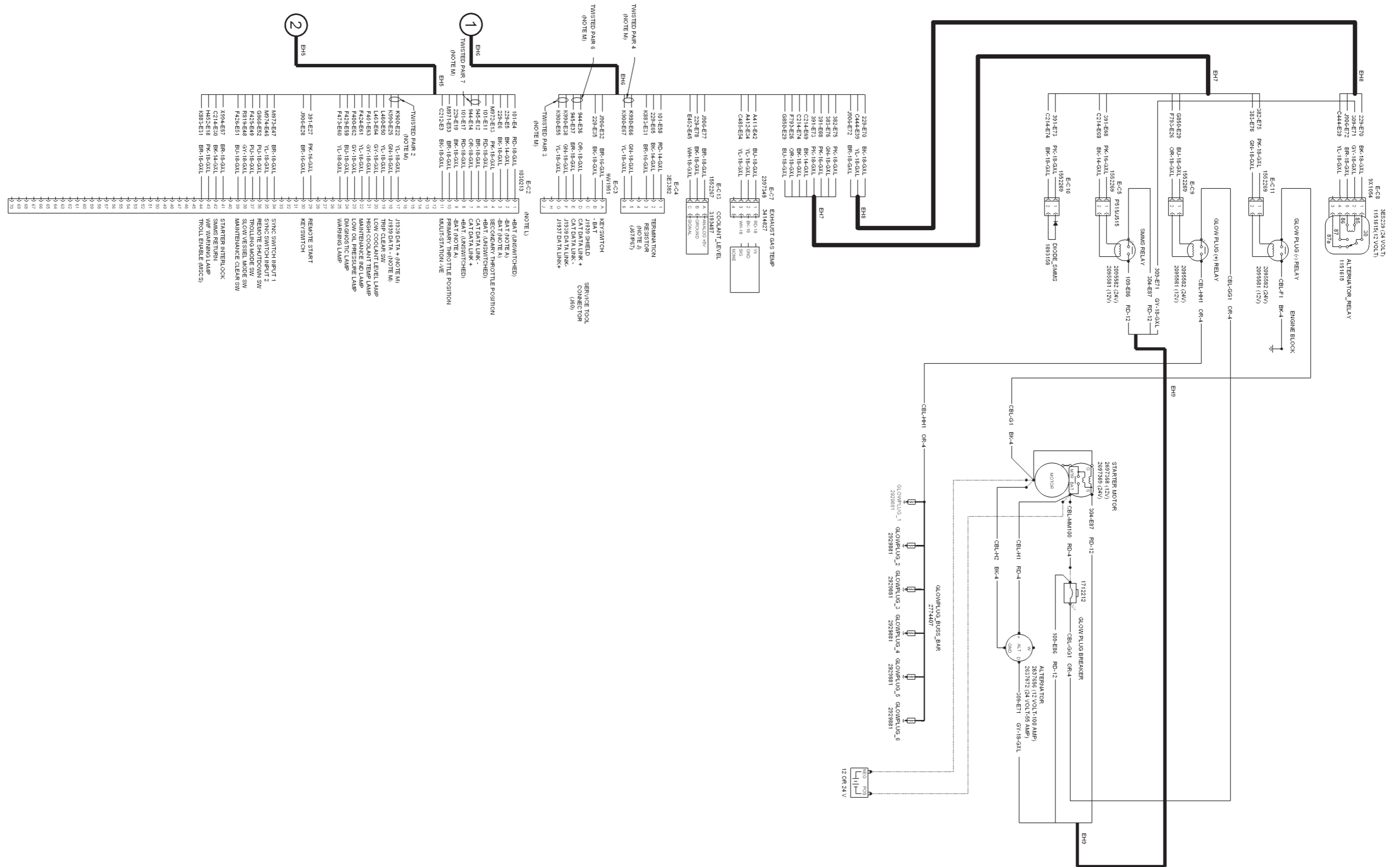

\*Engine wiring harness 2

\*See the CD for PC compatible version of this diagram.

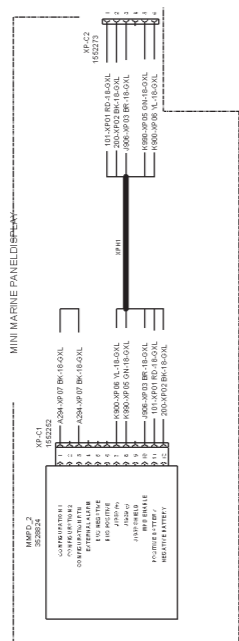

\*See the CD for PC compatible version of this diagram.

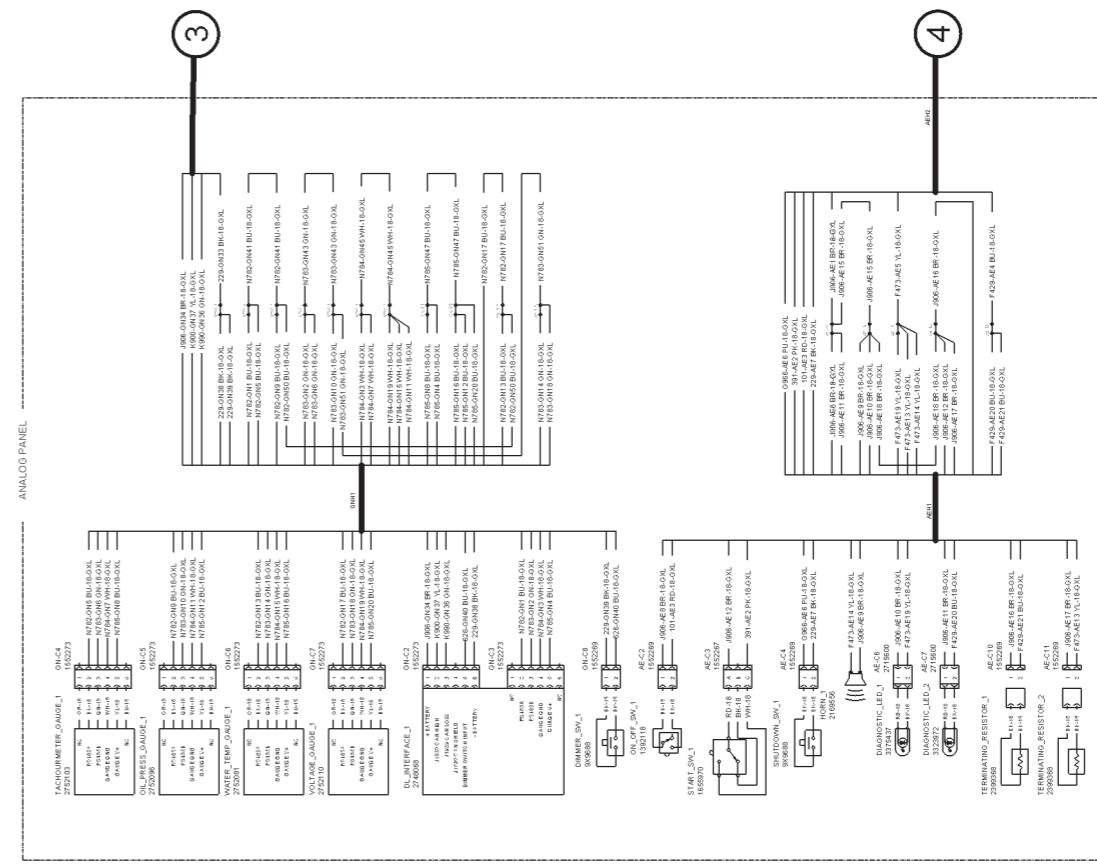
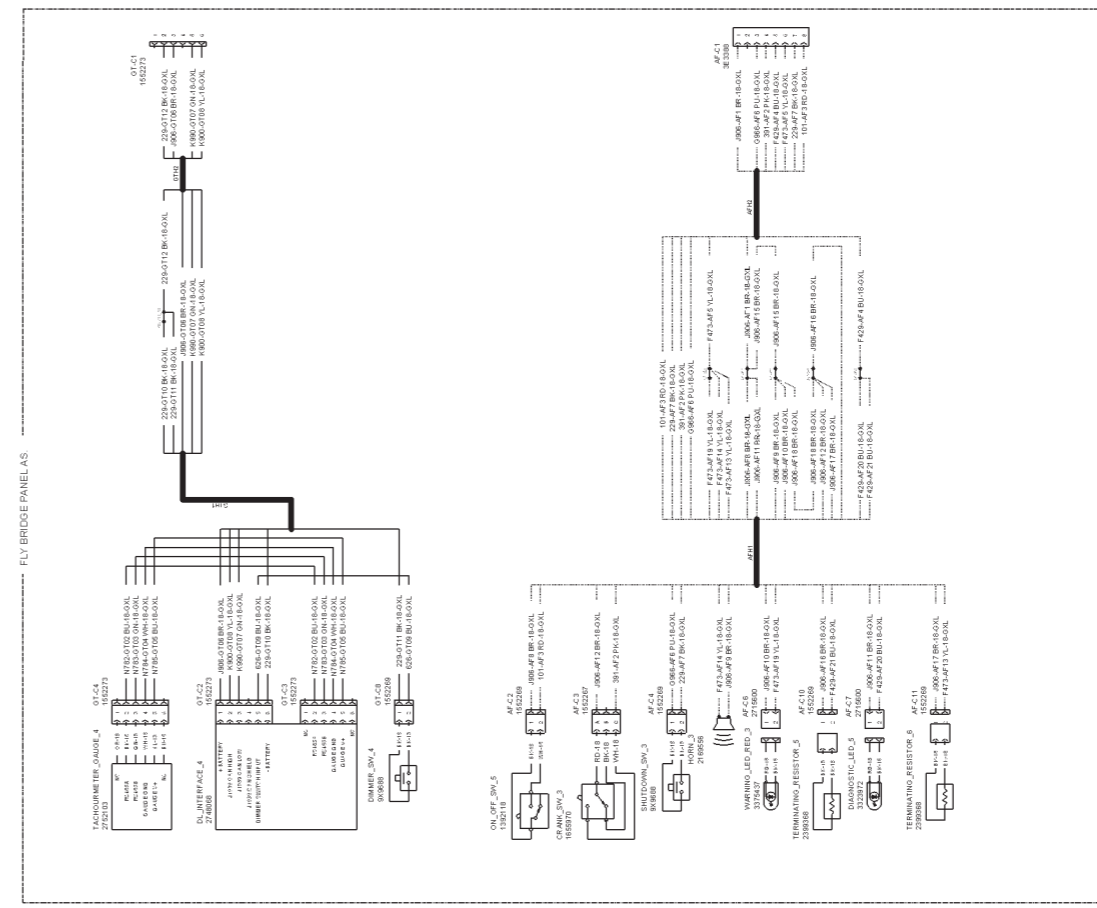
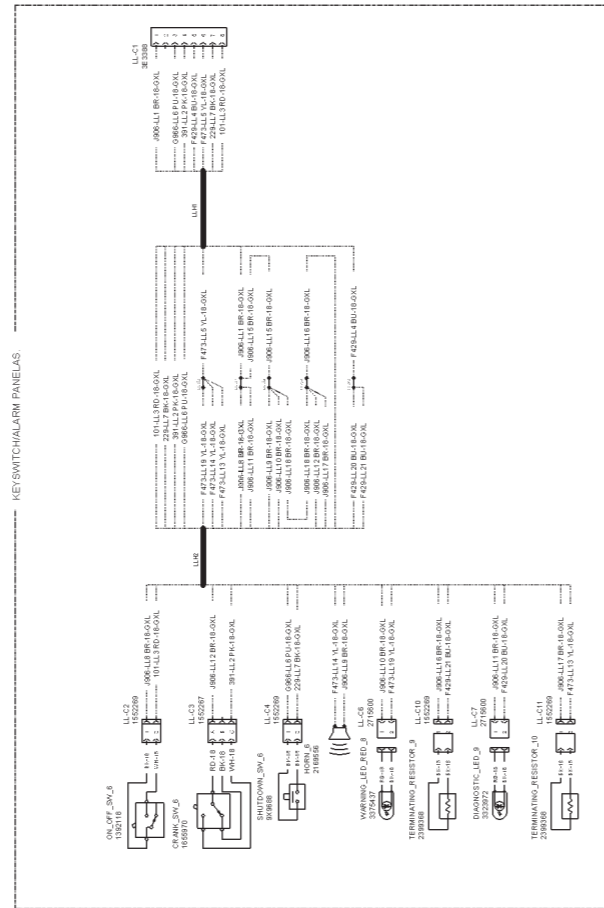

\*Engine panels 1

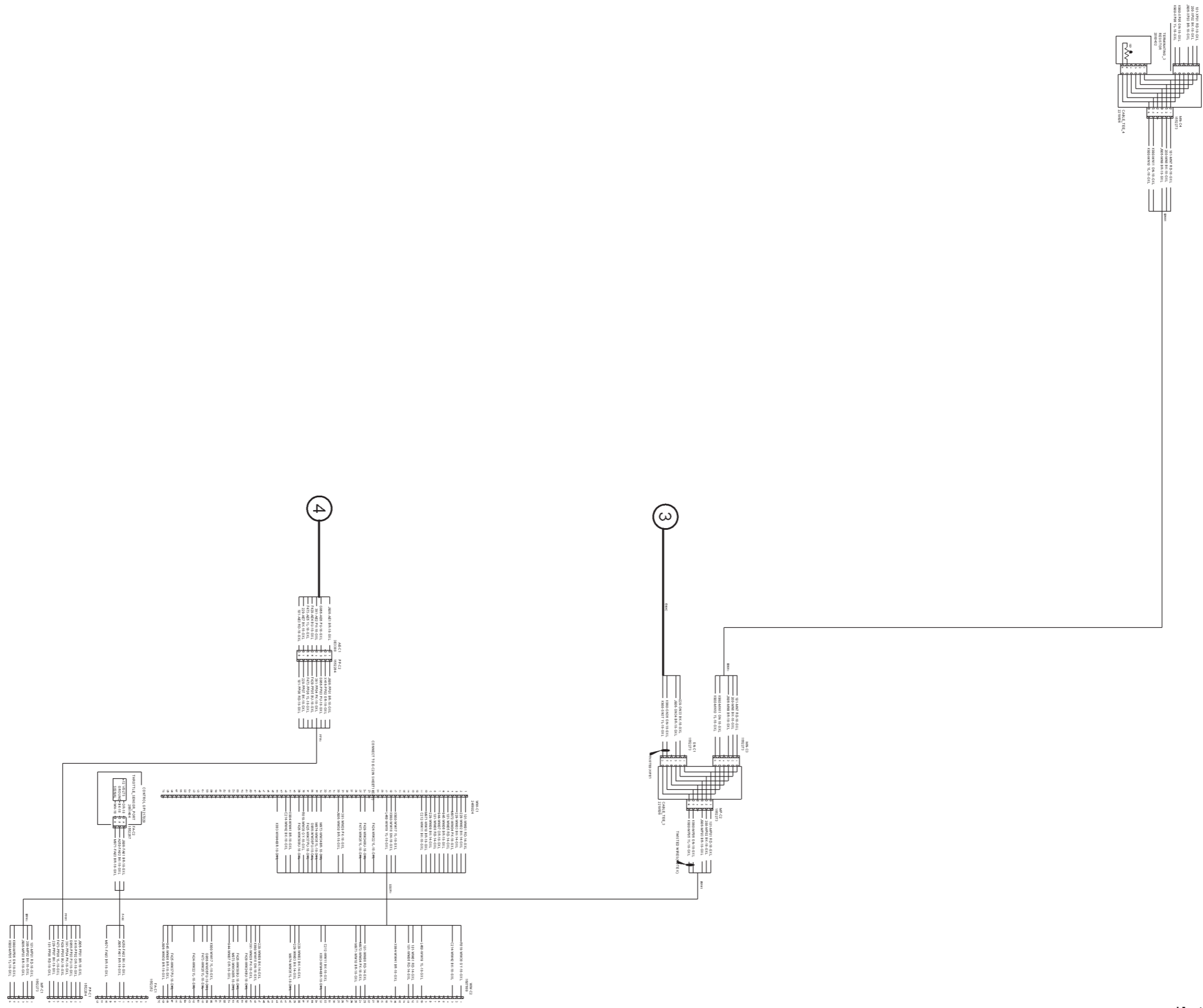

\*See the CD for PC compatible version of this diagram.

\*Interconnecting leads 1



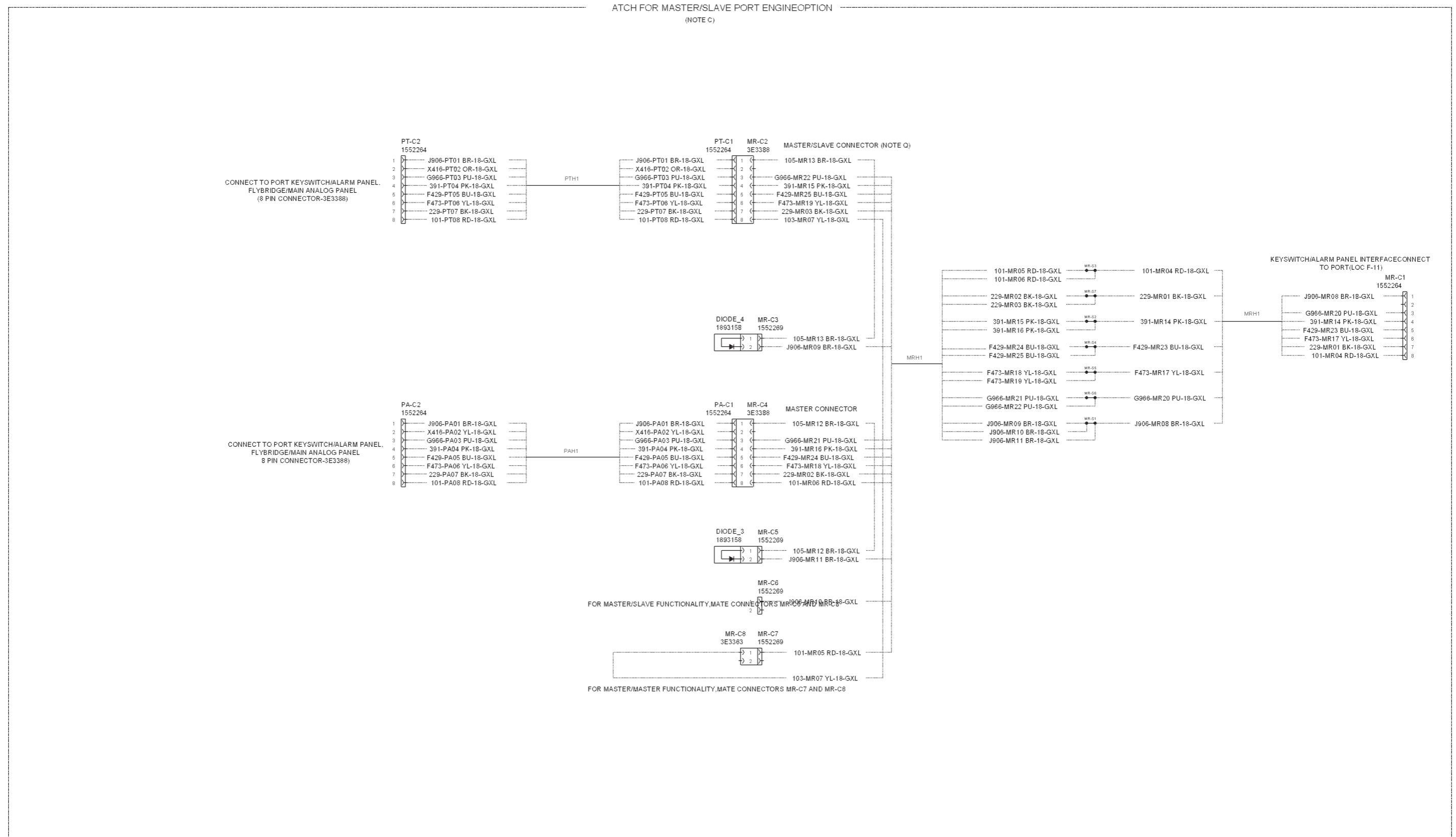

\*See the CD for PC compatible version of this diagram.

\*Master/slave option, port

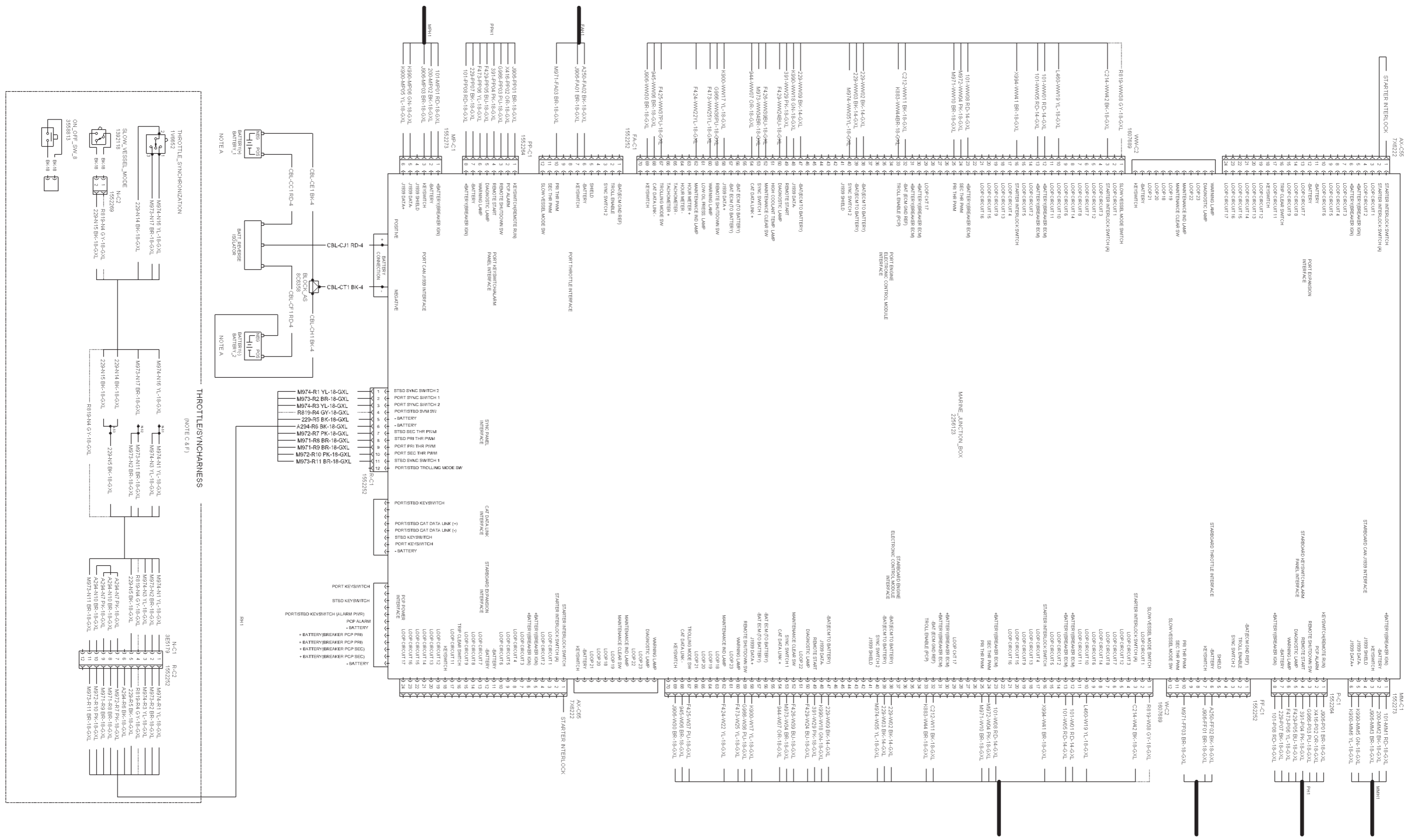

\*See the CD for PC compatible version of this diagram.

\*Marine junction box

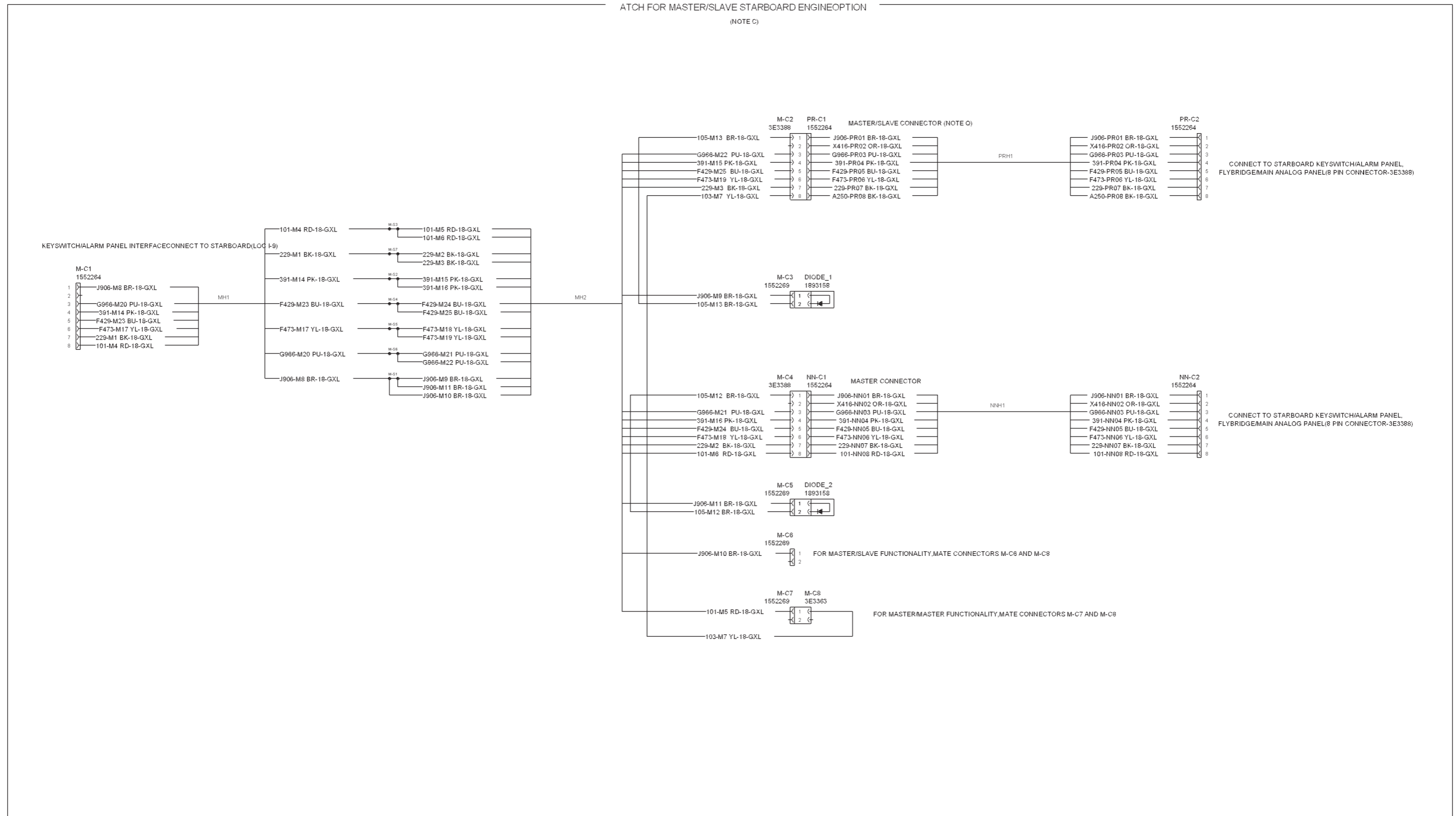

\*See the CD for PC compatible version of this diagram.

\*Master/slave option, starboard

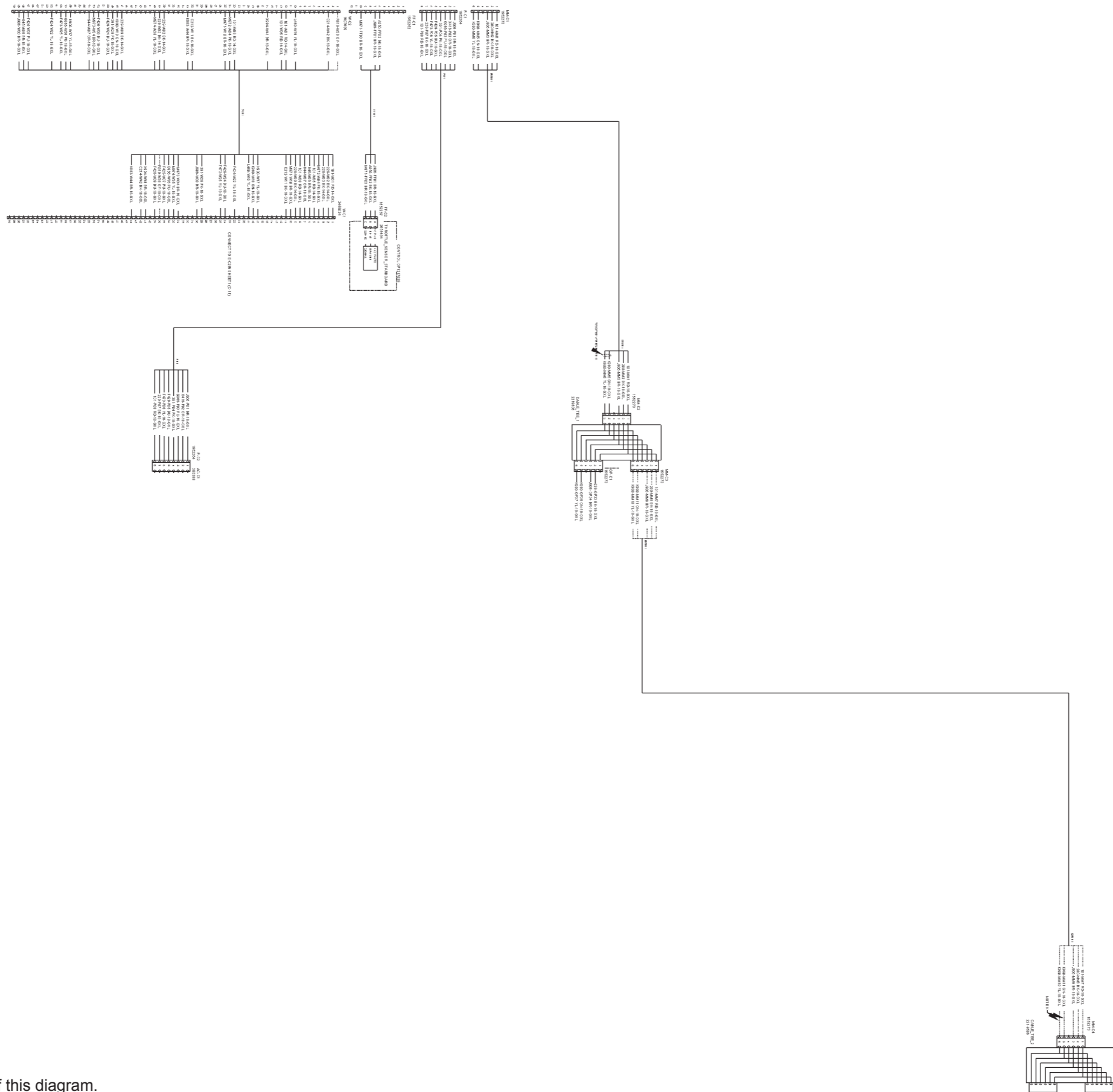

\*See the CD for PC compatible version of this diagram.

**\*Interconnecting leads 2**

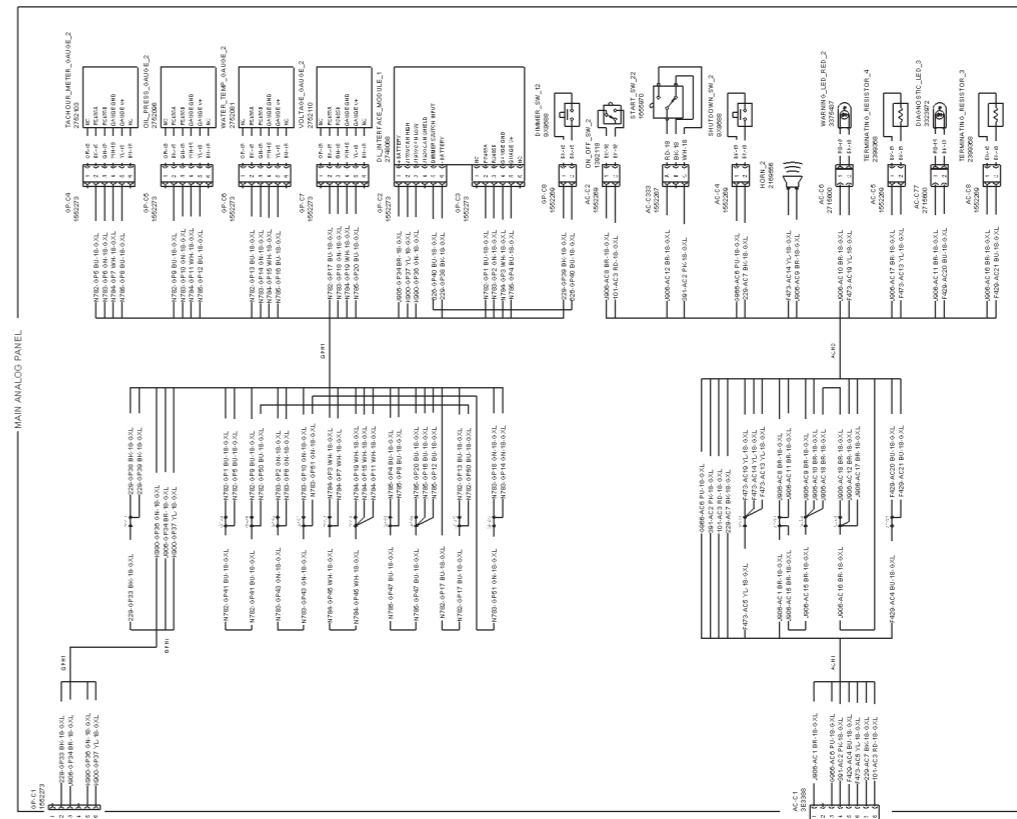
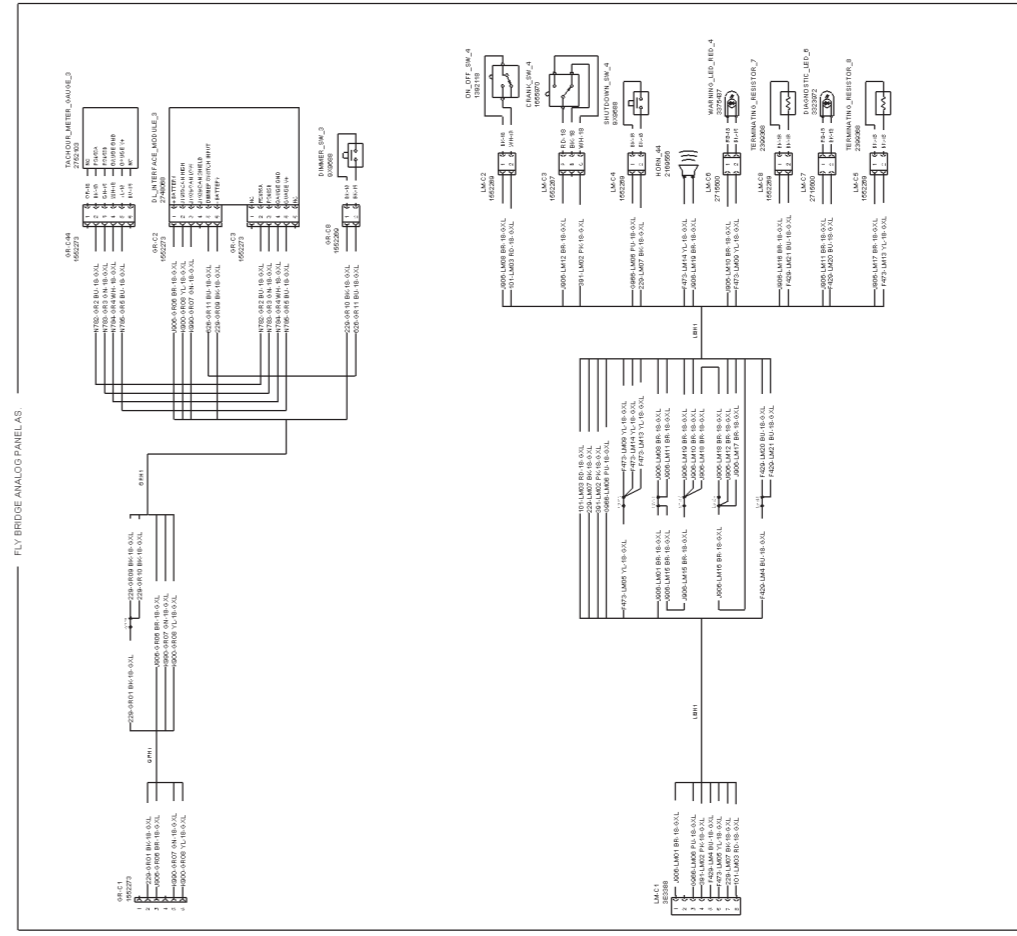
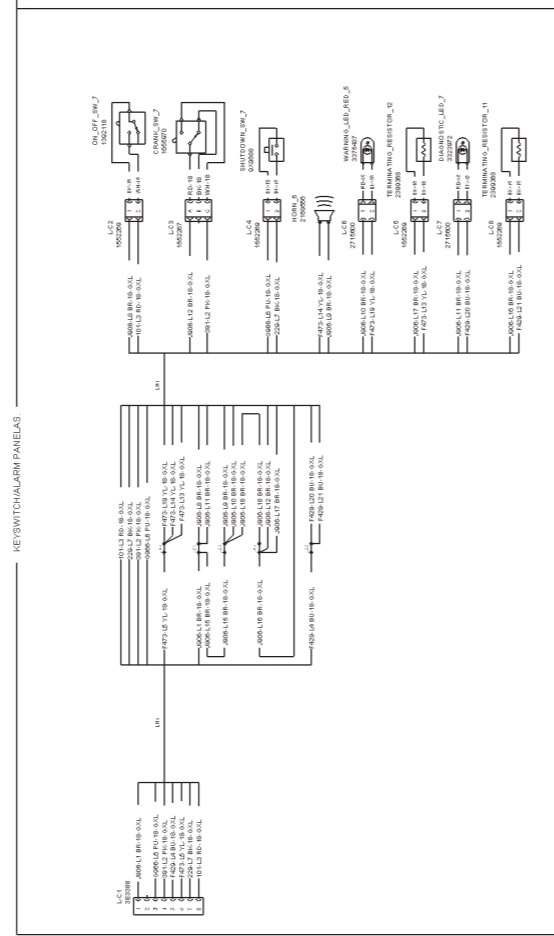
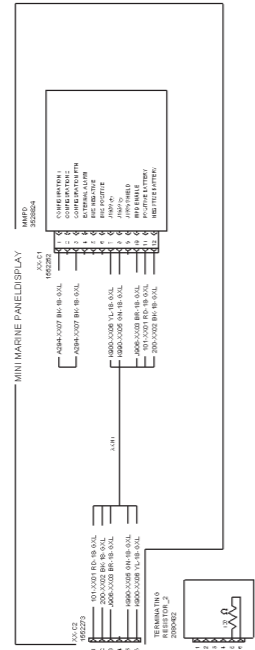

\*See the CD for PC compatible version of this diagram.

\*Engine panels 2



## Engine controls

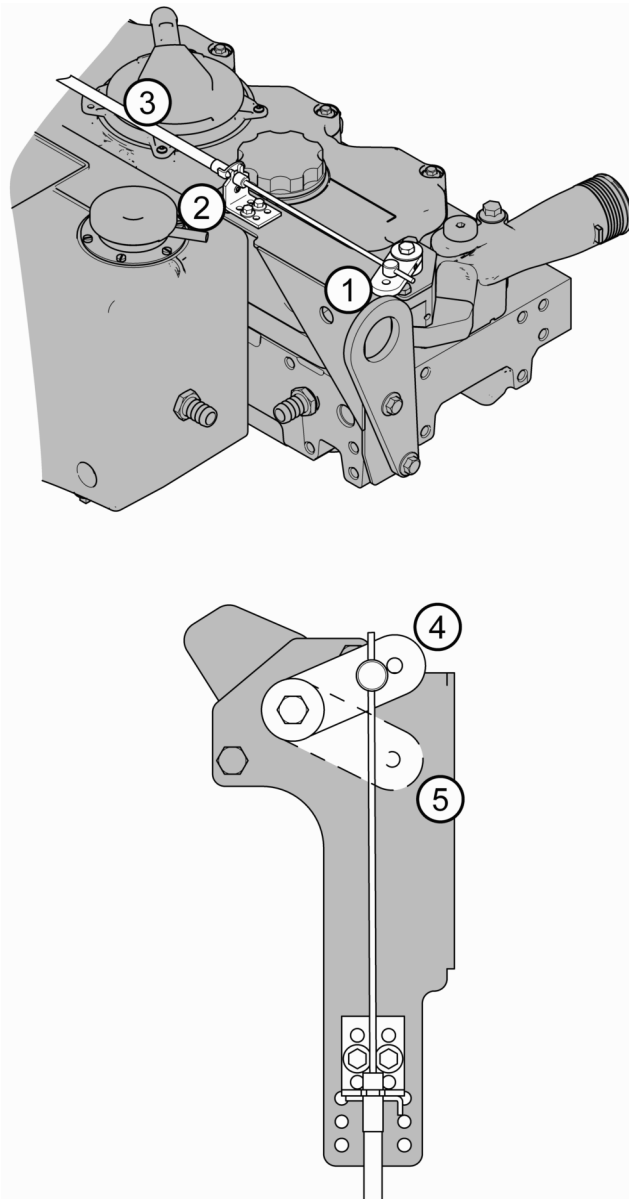

It is recommended that a Morse single lever system is used to control engine speed and gearbox engagement.

1. Throttle lever.
2. Anchor for Morse 33C cable.
3. Morse 33C cable.
4. Idle position.
5. Run position

Figure 1





## Provision for power take-off

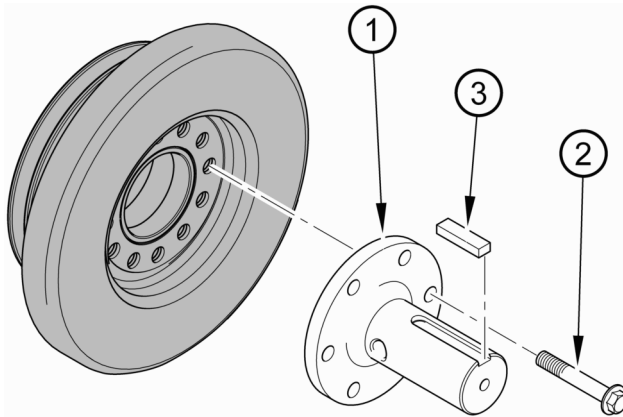

Figure 1

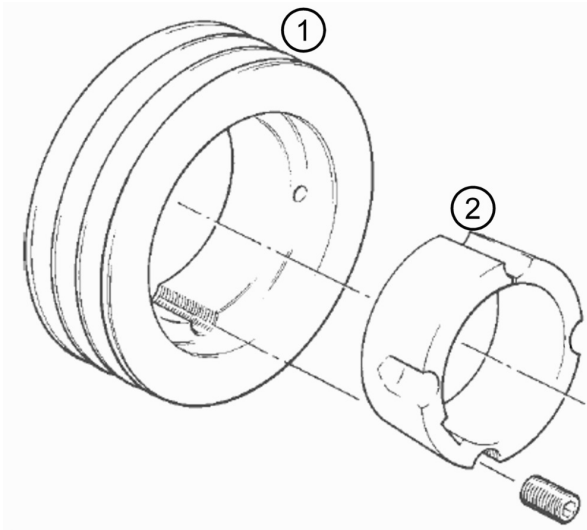

Figure 2

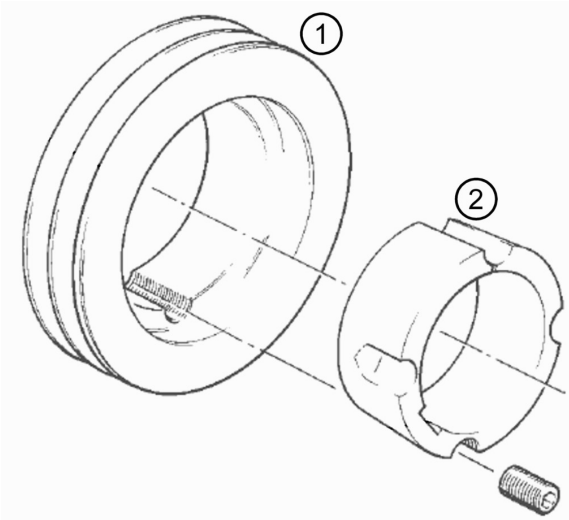

Figure 3

**Warning!** Remove all paint traces from the mating faces before assembly.

Fit the power take-off shaft, (figure 1 item 1) using bolts (figure 1 item 2) and tighten to a final torque of 84 lb.ft. (115Nm)

Fit the key (figure 1 item 3) to the power take-off shaft

### For axial drives

For axial drives it is recommended that a flexible drive coupling between the engine and any given load is used.

### For belt drives

Standard options are:-

Either a 5" 'A' section pulley with three grooves (figure 2 item 1) and a taper lock (figure 2 item 2).

or

A 5" 'B' section pulley with two grooves (figure 3).

In this case the maximum power which can be taken will be limited by the belts, and it will be necessary to calculate for marginal applications.

**Caution:** Additional inertia must not be added to the P.T.O. shaft without specialist advice. Consult your distributor if you need advice about non-standard drive arrangements.

**Polar diagram**

This diagram shows the loading capability of the front of the crankshaft.

The load angle, when viewed from the front of the engine, is measured clockwise, with 0° aligned to TDC.

Overhung load (Newtons) is directed radially outwards from the centre of the diagram.

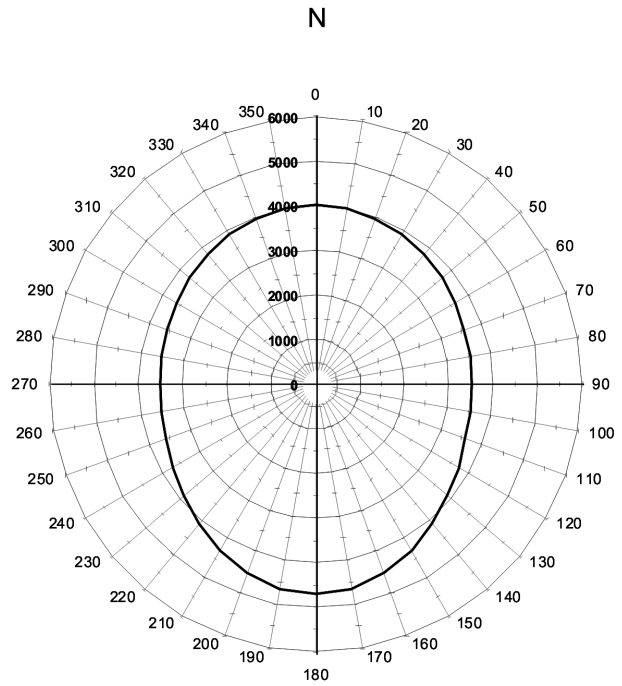

**Figure 4**

## Calorifier and block heater connections

### Calorifier

Fittings are available to allow a calorifier to be connected to the engine, as shown in figure 1. The fittings may be ordered as part of the engine assembly, or as loose parts to be fitted later.

The hose connections to the calorifier must be of a radiator or heater hose quality and 1/2" bore, and must be installed so that chafing will not occur.

(1) Supply to calorifier.

(2) Return from calorifier.

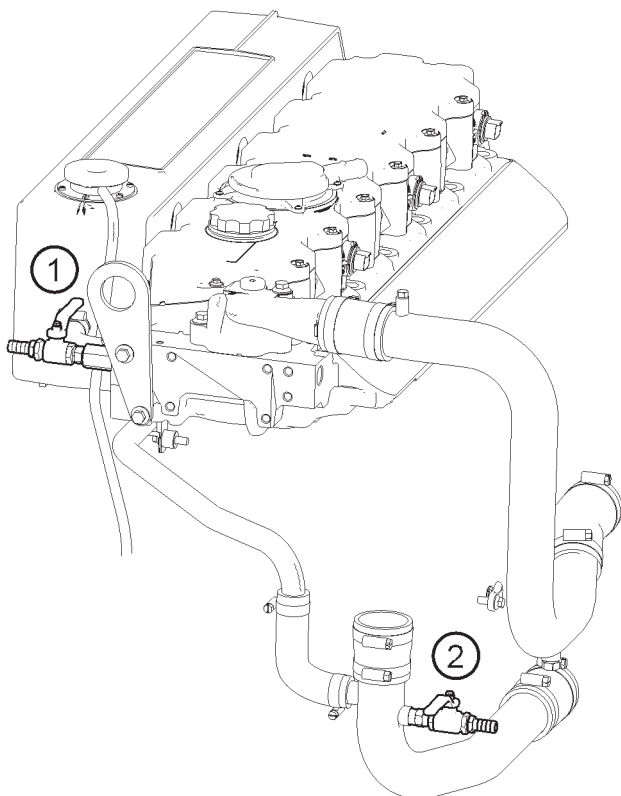

Figure 1

### Block heater connection points

A mains powered cylinder block heater may be fitted to keep the engine warm when the boat is stored in low temperatures. A suitable heater may be ordered as part of the engine assembly, or may be fitted later.

Figure 2 shows the connection point. The core plug in the position shown on the engine block is removed and the block heater fitted and secured with a bolt.

If the heater is ordered at the same time as the engine, it can be attached to the engine.

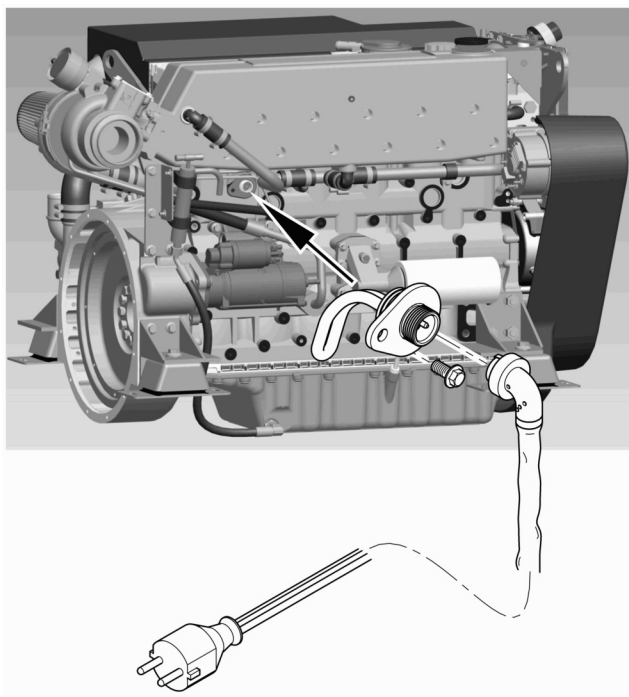

Figure 2



## Options

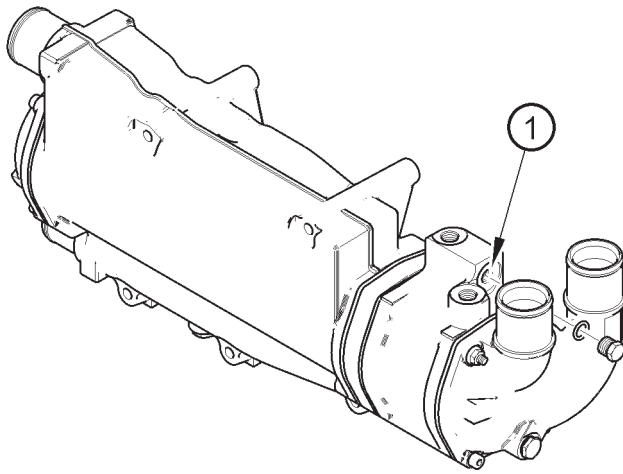

Figure 1

**Gearbox oil temperature sensor**

Gearbox sensors are available as an option. Please refer to the gearbox manufacturers handbook for installation requirements.

Use the M12 tapping as shown in figure 1 for the transmission temperature sensor or refer to the gearbox manufactures handbook.



## Reference data

<b>Basic data</b>	<b>M300C</b>	<b>M250C</b>	<b>M216C</b>	<b>M190C</b>
Rated power .....	300hp (225kW) .....	250hp (186kW) .....	216hp (161kW) .....	190hp (142kW)
Rated engine speed .....	2400rpm .....	2400rpm .....	2400rpm .....	2100rpm
Number of cylinders.....	6.			
Cylinder arrangement.....	In-line.			
Cycle.....	4 Stroke.			
Induction System.....	Turbocharged aftercooling.			
Bore .....	105mm (4.13").			
Stroke .....	127mm (5.00").			
Compression Ratio .....	16.2:1.			
Cubic Capacity .....	6.6 Litre (365 in <sup>3</sup> ).			
Valves per cylinder .....	4.			
Direction of Rotation .....	Anti-clockwise viewed from flywheel.			
Firing Order .....	1, 5, 3, 6, 4, 2.			
Total Weight (wet).....	738kg .....	738kg .....	736kg .....	736kg

**Cooling**

Cooling System .....	The coolant shown is mandatory for use in all climates to ensure that adequate levels of corrosion inhibitor are present. It will give frost protection to -37°C.
Coolant .....	50% inhibited ethylene glycol or 50% inhibited propylene glycol with 50% fresh clean water.
Fresh Water Flow .....	220 l/min at 2400 rpm... 220 l/min at 2400 rpm .. 220 l/min at 2400 rpm .. 193 l/min at 2100 rpm
Coolant pump speed and method of drive.....	1:1 Gear Driven.
System Capacity.....	26.3 litres (5.7 gallons).
Pressure cap setting.....	50kPa (7psi).
Sea water pump type.....	Gear driven full cam.
Sea water suggested inlet .....	32mm Bore (1.25") hose diameter.
Sea cock.....	Full flow 32mm (1.25")
Strainer .....	Auxiliary water strainer must be included in suction side of the circuit
Maximum sea water temperature .....	38°C (100°F)
Sea water flow .....	137 l/min at 2400rpm ... 137 l/min at 2400rpm .... 137 l/min at 2400rpm .... 128 l/min at 2100rpm

**Fuel system**

Recommended fuel .....	DIN E 590 DERV (class A-F & 0-4)
	BS2869 Class A2 (Off highway, gas oil, red diesel)
	ASTM D975-91 Class 1-1DA & Class 2-2DA
	JIS K2204 (1997) Grades 1, 2, 3 & Special grade 3
Fuel injection pump .....	CR200
Fuel lift pump .....	manual
Fuel feed pressure (static).....	0.3 to 0.6 bar (5 to 8psi)
Governor type.....	A4:E2
Pipe size:	
• Supply - outside diameter .....	10mm (0.394")
• Supply - bore .....	8.4mm (0.331")
• Return - outside diameter.....	10mm (0.394")
• Return - bore .....	8.4mm (0.331")
Maximum lift pump lift.....	1.8m (6ft) to bottom of tank suction pipe.
Maximum fuel lift pump .....	127mm (5 inches) Hg depression at inlet.
Fuel consumption at full .....	62 l/hr ..... 51.9 l/hr ..... 44.74 l/hr..... 37.03 l/hr

**Air intake**

Combustion airflow .....	15.7m <sup>3</sup> /min..... 15.04m <sup>3</sup> /min ..... 14.6m <sup>3</sup> /min..... 12.33m <sup>3</sup> /min
Maximum engine compartment .....	60°C.
air temperature.	
Maximum air temperature at.....	52°C.
engine inlet	
Ventilation - maximum engine .....	125mm WG (5" WG).
room depression	
Minimum cross section .....	968cm <sup>2</sup> for hot climates .. 806cm <sup>2</sup> for hot climates...697cm <sup>2</sup> for hot climates.. 613cm <sup>2</sup> for hot climates
of air duct (per engine). .....	484cm <sup>2</sup> for temp climates .403cm <sup>2</sup> for temp climates. 348cm <sup>2</sup> for temp climates 306cm <sup>2</sup> for temp climates

**Exhaust**

Exhaust gas flow .....	45.9m <sup>3</sup> /min..... 36.8m <sup>3</sup> /min ..... 27.13m <sup>3</sup> /min..... 22.97m <sup>3</sup> /min
Maximum restriction measured .....	15kPa
within (305mm) 12" of turbocharger outlet .	
Recommended pipe bore (wet exhaust) .....	127mm (5.0")
Recommended pipe bore (dry).....	69mm (2.7")
Minimum rise from sea level to.....	203mm (8.0")
exhaust outlet centre-line	



**Lubricating system**

Recommended lubricating oil ..... API / CH4 / CI-4  
Sump capacity maximum ..... 15 litres (3.3 gallons)  
Maximum operational angle ..... 20° nose up. Heel 25° constant, 35° intermittent  
Oil pressure in operating ..... 3.6 bar  
speed range (steady state)

**Electrical system**

Alternator ..... Insulated return 12 Volt-100 amp or 24 Volt-55 amp  
Starter type ..... 4.0Kw  
Number of teeth in flywheel ..... 126  
Number of teeth on starter ..... 10

**Cold start limits**

Minimum cold start temperature (with aid) ..... -15°C (5°F)



# Index

## A

Absorbent material ..... 15  
Activate station button status..... 33  
Activate station lamp status..... 33  
Active diagnostic code..... 42  
Active diagnostic status..... 34  
Active station lamp status..... 32  
Active station location..... 32, 33, 34  
Adjuster nut ..... 5  
Aftercooler ..... 18  
Aftercooler circuit..... 18  
Aftercooler grid cooler ..... 18  
Aft station..... 32, 33  
Air ..... 15  
Airborne dirt ..... 19  
Air duct ..... 15  
Air entry vents..... 15  
Air flow..... 15  
Air intake..... 15  
Air locks ..... 18, 21  
Air temperature..... 15  
Alarm button ..... 31, 32, 33  
Alarm mute ..... 28  
Alarm tank ..... 22  
Alignment..... 4  
Alloys ..... 17  
Alternator ..... 15, 23  
Aluminium..... 17, 21  
Ambient temperature ..... 15  
Angular misalignment..... 7  
Anodes ..... 17  
Armoured rubber hose..... 21  
Assembly faults ..... 19  
Audible alarm..... 28  
Auxiliary ..... 23  
Auxiliary panel ..... 30  
Auxiliary water ..... 9  
Auxiliary water pump ..... 18  
Auxiliary water systems ..... 17  
Auxiliary panel ..... 25  
Average fall..... 12  
Axial drives ..... 63

## B

Back pressure..... 12, 13  
Baffles..... 20  
Balancing pipe..... 21  
Batteries ..... 40  
Battery ..... 25, 38, 39, 44  
Battery ..... 25, 42  
Battery bus bar ..... 42  
Battery cables..... 40  
Battery isolator switches..... 44  
Battery lead ..... 25  
Battery negative..... 40  
Battery power ..... 40  
Battery reverse isolator..... 40  
Battery selection tables ..... 43  
Battery type ..... 43

Battery voltage..... 43  
Bellows ..... 10  
Belt drives..... 63  
Bilge..... 15  
Blanking plugs ..... 23  
Bleed ..... 18  
Blockage..... 17  
Block heater..... 65  
Block heating ..... 43  
Boat builder ..... 7  
Boat designer ..... 7  
Bonding ..... 44  
Bonding stud..... 1  
Bonding system..... 40, 45  
Bore ..... 17, 18  
Bow station ..... 32, 33  
Breakers ..... 23, 24, 38, 39  
Bridge ..... 32, 33  
Bulkhead..... 10  
'Bundy' steel tubing ..... 21  
Busbar ..... 40, 42  
Button status indicator ..... 33

## C

Cable ..... 30, 45  
Cable length ..... 40  
Cables ..... 25, 35  
Calorifier ..... 65  
Cancel ..... 33  
Can data..... 35  
Can data link..... 32  
Cap ..... 19  
Cavity..... 22  
Centrifugal force ..... 7  
Change display units ..... 32  
Change display units ..... 31  
Change engine sync master..... 33  
Change screen ..... 32, 33  
Change screen ..... 31, 32  
Change set speed ..... 32  
Change station location..... 32  
Change sync master..... 32  
Change system information screen..... 32  
Change troll mode ..... 32, 33  
Change troll speed ..... 33  
Change unit location..... 31, 32  
Change user ..... 31, 32  
Change vessel speed ..... 31  
Change vessel speed units ..... 31, 32  
Clamps ..... 10  
Cleaning ..... 17, 20  
Cleanliness ..... 19  
Clips..... 23  
Cold mode ..... 29  
Cold start system..... 43  
Collector tank..... 22  
Combustion ..... 15  
Combustion noise..... 13

Common bonding wire..... 45  
Component failures ..... 42  
Compression fittings ..... 19, 21  
Condensate ..... 11  
Configuration screen ..... 29  
Connections..... 65  
Connectors ..... 23  
Constant velocity joints..... 7  
Contamination ..... 19  
Control processor ..... 38, 39  
Control stations..... 40  
Control system..... 42  
Control system information..... 31, 32  
Control system information screen..... 32  
Coolant level..... 45  
Coolers ..... 18  
Cooling systems ..... 1  
Cooling water..... 13  
Copper..... 17, 21  
Core plug ..... 65  
Corrosion inhibitors..... 18  
Cranking speed ..... 43  
Crankshaft ..... 64  
Cross connection..... 20, 21  
Cross section..... 15  
Cross sectional area..... 15  
Cupro-nickel ..... 17  
Current draw..... 40  
Custom ..... 38  
Customer connect harness..... 36  
Customer connector ..... 40  
Custom panel connector..... 42  
Custom (port side)..... 39  
Custom (starboard side)..... 39  
Cutless bearing..... 7  
Cutout dimensions..... 26, 28  
Cylinder jacket..... 18  
Cylinder jacket circuit..... 18  
Cylinder jacket grid cooler ..... 18

## D

Data link..... 32, 35, 40  
Debris ..... 19  
Deflector baffles..... 15  
Derate event code ..... 42  
Diagnostic code ..... 31, 32  
Diagnostic flash codes..... 42  
Diagnostic icon ..... 34  
Diagnostic lamp ..... 26, 28, 42  
Diesel fuel tank..... 19  
Digital..... 23  
Digital panel..... 28, 30  
Dirt..... 19, 23  
Disabled..... 29  
Display..... 28  
Display units ..... 31, 32  
Distributor ..... 19  
Drain..... 21

Drain tap.....	20, 21	Expansion.....	38	G.R.P.....	21
Dry riser.....	12	Expansion connectors.....	41	Gun-metal.....	17
Dry systems.....	11	Expansion (port side).....	39	<b>H</b>	
Dual engine installation.....	29	Expansion (starboard side).....	39	Harness.....	23, 25, 50
Duplex fuel pipes.....	22	<b>F</b>		Heat.....	23
<b>E</b>		Fault codes.....	28	Heat blanket.....	11
Ecm.....	22, 37, 38, 42	Fault condition.....	42	Heater.....	65
Ecm and battery.....	36	Feed pipes.....	21	Heat exchangers.....	9
Ecm port.....	40	Fibre washers.....	19	Heat rejection.....	18
Ecm (port side).....	39	Filler cap.....	20	Heel angle.....	3
Ecm (starboard side).....	39	Filler neck.....	20	High air temperatures.....	15
Electrical grease.....	23	Fire risk.....	11	High output.....	15
Electrical systems.....	2	Flexibility.....	10	High pressure fuel lines.....	19
Electric stop.....	23	Flexible drive coupling.....	63	High pressure water.....	19
Electrolytic corrosion.....	17, 44	Flexible engine mounts.....	4	High rise extension.....	12
Electronic engine controller (ecm).....	23	Flexible fuel pipes.....	20	High temperature.....	11
Electronic service tool.....	42	Flexible hanger.....	12	Holding down bolts.....	4
Electronic throttle.....	30	Flexible hose.....	17	Horsepower.....	15
Enabled.....	29	Flexible mountings.....	7, 17, 18	Hose clamps.....	19
Engine.....	25	Flexible shaft couplings.....	7	Hot air.....	15
Engine bearers.....	4, 6	Flow of air.....	15	Hot climates.....	15
Engine circuit diagram.....	23	Flow problems.....	17	Hull 15, 17, 44	
Engine compartment.....	15	Fly bridge.....	32, 33	Hull movements.....	7
Engine controls.....	61	Flying lead.....	23	<b>I</b>	
Engine cooling systems.....	17	Foreign matter.....	22	Idle (neutral) lockout button.....	33
Engine crank.....	26, 28	Fresh water pump.....	18	Idle (neutral) lockout lamp.....	33
Engine electrical systems.....	23	Front facia.....	26	Idle position.....	61
Engine feed.....	22	Front lifting eye.....	1	Ignition.....	36
Engine hours/fault code display.....	26	Fuel.....	19, 21, 22	Incompatible connectors.....	19
Engine installer.....	7	Fuel connection.....	19, 21	Information screens.....	31
Engine interaction.....	21	Fuel feed.....	1, 20	Injectors.....	19, 23
Engine interface (ecm).....	36	Fuel feed tap.....	21	Inlet connection.....	17
Engine location.....	31	Fuel filters.....	19	In-line silencer.....	13
Engine mounting.....	3	Fuel level.....	45	Inner fuel pipe.....	22
Engine mounting brackets.....	4	Fuel lines.....	21	Installation angles.....	3
Engine mounting point.....	1, 2	Fuel pipes.....	20	Instrument panel.....	23, 25, 26
Engine panels.....	53, 59	Fuel return.....	2, 20	Insulating blanket.....	10
Engine room.....	15, 32, 33	Fuel return pipe.....	21	Insulating lagging.....	11
Engine room ventilation.....	15	Fuel supply pressure.....	45	Insulation.....	45
Engine senders.....	23	Fuel surge.....	20	Intake fitting.....	17
Engine speed.....	32, 61	Fuel system.....	19	Intake vents.....	15
Engine stop switch.....	26, 28	Fuel system problems.....	19	Integral oil cooler.....	18
Engine synchronization.....	34	Fuel tank.....	19, 20, 21, 22	Intelli-troll.....	33
Engine synchronization button.....	33	Fuel temperature.....	45	Interconnecting cables.....	23, 25
Engine synchronization lamp.....	33	Full flow.....	17	Interconnecting leads.....	54, 58
Engine sync master.....	32, 33	Fuse.....	36	Interference.....	40
Engine wiring looms.....	23	<b>G</b>		Ip 65.....	26
Environment.....	19	Gas.....	12	Ip 67.....	23, 28, 26
Est.....	29	Gearbox.....	67	Iron.....	17
Excessive temperature.....	15	Gearbox control options.....	30	<b>J</b>	
Exhaust.....	13	Gearbox coupling.....	7	J61.....	40
Exhaust back pressure.....	9	Gearbox engagement.....	61	J1939.....	25, 35, 36, 38
Exhaust bore.....	9	Gearbox oil cooler.....	18	J1939 (port side).....	39
Exhaust elbow.....	10	Gearbox oil temperature sensor.....	67	J1939 (starboard side).....	39
Exhaust gases.....	9, 12, 13	Gear position.....	34	Jumper wire.....	41
Exhaust gas temperature.....	45	General arrangement.....	4	Junction box.....	37
Exhaust manifold.....	18	Glass fibres.....	19	<b>K</b>	
Exhaust outlet.....	9, 12	Glow plugs.....	43	Keel cooling system.....	18
Exhaust pipe.....	9	Gradient.....	13		
Exhaust riser.....	12	Gravity.....	22		
Exhaust system.....	1, 9, 13	Grounding.....	40		
Exhaust tank.....	12				
Exit.....	31, 32				

Key .....	63
Key/alarm .....	38
Key/alarm (port side) .....	39
Key/alarm (starboard side) .....	39
Keyswitch .....	36, 37, 42
Keyswitch on/off .....	26, 28
Keyswitch panel.....	23, 25, 28, 30
Knots .....	31, 32

## L

Labelled change screen .....	31
Lamp status indicator .....	33
Legislation .....	21
Load angle.....	64
Loading.....	64
Logs.....	17
Loose debris .....	19
Low idle .....	29
Low temperatures.....	65

## M

Magnesium .....	17
Main.....	23, 25
Main panel.....	26, 30
Main tank.....	22
Maintenance clear switch .....	42
Manual fuel feed.....	21
Marine junction box .....	25, 37, 40, 56
Mass elastic data.....	7
Master/slave lead .....	25
Master/slave option .....	55, 57
Master throttle.....	29
Menu.....	31, 32
Metal.....	21
Metallic particles .....	19
Mini marine power display (mmpd)....	30, 31, 32, 33, 35
Mini marine power display .....	28
Minus battery .....	40
Mjb (marine junction box) .....	25, 36, 40
Mmpd.....	32, 33, 35
Mmpd, digital panel .....	25
Modular exhaust.....	12
Moisture.....	23
Monitoring.....	37
Morse 33c.....	61
Mounting brackets .....	1, 2
Mscs .....	40
Multiple instrument panels.....	23
Multiway connector.....	23

## N

Naval architect.....	7
Negative glow plug .....	24
New components.....	19
Noise .....	7, 13
Noise absorbent material.....	15
Noise absorbing chambers.....	15
Noise levels .....	13
Non-volatile memory.....	31
Nose down capability.....	3
Number of synchronized engines configuration.....	29

## O

Oil .....	43
Oil filter .....	24
Oil pressure gauge .....	26
Open cockpits.....	15
Operating range.....	22
Operational angles .....	3
Optional harness .....	23
Overboard outlet.....	12
Overheat.....	15
Overhung load.....	64

## P

Paint .....	63
Panel illumination .....	26
Parameters .....	28
Parameter screens .....	34
Part dry.....	12
Part wet .....	12
Pcp .....	32, 33, 35
Pdl connector.....	38, 39
Pin .....	23
Pinch points .....	23
Pipework.....	17, 18
Plug-together .....	23
Pm1 .....	42
Polar diagram .....	64
Port wing.....	32
Position sensor .....	29
Positive glow plug.....	24
Positive lead .....	44
Possible panel configurations.....	30
Power connections .....	40
Power supply .....	30
Power take-off .....	63
Powertrain control processor (pcp)....	32
Pressure .....	12
Pressure tightness.....	19
Primary fuel filter.....	21
Propeller shaft .....	7, 45
Propeller shafts and couplings .....	7
P.T.O .....	63
Pulley.....	63

## R

Racking.....	6
Radiator.....	65
Ram airflow.....	15
Rear lifting eye.....	2
Refuelling.....	19
Refuelling pump.....	19
Remote kit .....	18
Remote tank .....	18
Return pipes .....	21
Return systems.....	22
Reverse isolator.....	40
Reverse video.....	31, 32, 34
Rigid bracket.....	11
Rom bootloader software version...31	
Routine examination.....	17
Rubber bag.....	21
Rubber exhaust hose .....	9
Rubber hose connections.....	17

Rubbish .....	19
Rudders.....	17
Run position.....	61

## S

Sae j1939-15 .....	35
Safety switch .....	41
Sailing craft.....	12
Save .....	33
Screen illumination .....	28
Screens .....	28
Scroll back button.....	28
Scroll forward button.....	28
Sea cock.....	45
Sea level.....	45
Sealing compounds.....	19
Sealing plugs .....	19
Seals.....	19, 23
Sea water .....	44, 45
Sea water pump .....	17
Sea water strainer .....	17
Sea water system.....	17
Secondary throttle .....	29
Secondary throttle enable status...29	
Sediment .....	20
Sensors .....	22, 45, 67
Service area .....	19
Service problems.....	19
Shaft .....	63
Shaft alignment.....	6
Shaft log .....	7
Shafts .....	17
Shaft seal.....	7
Sharp edges .....	23
Shims5	
Short circuits.....	24
Silencer.....	13
Silver solder.....	17
Simple fuel system .....	22
Single engine mjb.....	38
Single fuel tank.....	21
Siphon break .....	12
Slow speeds .....	29
Slow vessel mode.....	34, 36
Slow vessel mode button status ....33	
Slow vessel mode lamp status .....	33
Slow vessel mode panel.....	29
Socket alignment.....	23
Software version.....	31
Soldered nipples.....	21
Spray .....	15
Stainless steel bellows .....	11, 12
Stainless steel type 316.....	17
Standard brackets .....	4
Starboard interface connectors .....	40
Starboard wing .....	32, 33
Start aid type .....	43
Starter.....	23, 43, 44
Starter cables .....	1
Starter interlock .....	41
Starter lead resistance.....	43
Station button status.....	32
Status items.....	34
Steel .....	17, 21

Stop cock.....	21
Storage tanks .....	22
Strainer .....	17
Stud .....	44
Sump .....	20
Switched circuit.....	41
Synchronization switch .....	29
Syphon break .....	7
Siphoning.....	21
System information.....	31, 33

## T

Tachometer.....	26
Tank.....	20, 21
Taper lock .....	63
Tee connector .....	25, 35
Tee to tee.....	35
Temperate climates .....	15
Temperature .....	18, 43
Termination resistor .....	35
Thermostat .....	18
Thread details.....	20
Throttle synchronization panel.....	39
Throttle .....	25
Throttle .....	25, 36, 38
Throttle lever.....	61
Throttle (port side) .....	39
Throttle position .....	45
Throttles.....	29
Throttle (starboard side) .....	39
Throttle synchronization .....	29
Throttle synchronization panel.....	38
Throttle synchronisation .....	36
Thrust block .....	7
Torsional load .....	11
Torsional vibration analysis (tva) .....	7
Tower.....	32, 33
Traditional.....	33
Transmission oil pressure.....	45
Transmission oil temperature .....	45
Transmission operating data .....	31
Transom .....	9
Trap .....	11
Troll.....	34
Trolling mode button status .....	33
Trolling mode lamp status .....	33
Troll mode.....	32, 33
Troll set speed .....	33
Troubleshooting .....	42
Tube assemblies .....	19
Turbocharger .....	10, 12
Turbocharger adaptor .....	11
Twin engine mjb.....	39
Twin installation .....	6
Twisting.....	6
Two tanks .....	21
Typical fuel systems .....	21

## U

Uncovered apertures .....	19
Unit location.....	31, 32
Unit serial number .....	31
Unmachined faces.....	19

User name .....	31, 32
Users handbook .....	19

## V

Valves .....	20, 21, 22
'V' drives .....	5
Vent .....	21
Vent area .....	15
Ventilation .....	1, 15
Ventilation fans .....	15
Ventilation system.....	15
Venting points .....	18
Vent pipe.....	20, 22
Vessel control .....	37
Vessel locations .....	32
Vessel speed units.....	31, 32
Vessel status bar .....	34
Vibration .....	5, 7
Viscosity .....	43
Voltage gauge.....	26
Volume.....	12

## W

Warm climates .....	18
Warm conditions .....	15
Warning event code.....	42
Warning lamp .....	26, 28, 42
Warning light.....	26
Water .....	12, 20
Water/antifreeze .....	18
Water flow.....	18
Water injection .....	9, 10, 12
Water injection elbow .....	12
Water lift .....	7
Water lift systems .....	12
Water line .....	12
Waterline .....	9, 13, 17
Water lock.....	12
Water temperature.....	18
Water temperature gauge.....	26
Water trap.....	15
Wet systems .....	9, 12
Wheel house.....	15
Whirling.....	7
Wing .....	33
Wire .....	45
Wiring harness.....	48, 49, 51, 52

## Z

Zinc.....	17
Zinc anode.....	44
Zinc sacrificial anode .....	45

**California**

Proposition 65 Warning

Diesel engine exhaust and some of its constituents are known to the State of California to cause cancer, birth defects, and other reproductive harm.



**Perkins®**  
**Marine Power**

All information in this document is substantially correct at time of printing and may be altered subsequently.

Part No. N40475 issue 3

Produced in England ©2013 by Wimborne Marine Power Centre

**Wimborne Marine Power Centre**  
22 Cobham Road,  
Ferndown Industrial Estate,  
Wimborne, Dorset, BH21 7PW, England.  
Tel: +44 (0)1202 796000,  
Fax: +44 (0)1202 796001  
E-mail: [Marine@Perkins.com](mailto:Marine@Perkins.com)

Web: [www.perkins.com/Marine](http://www.perkins.com/Marine)