

Installation Manual

M92B

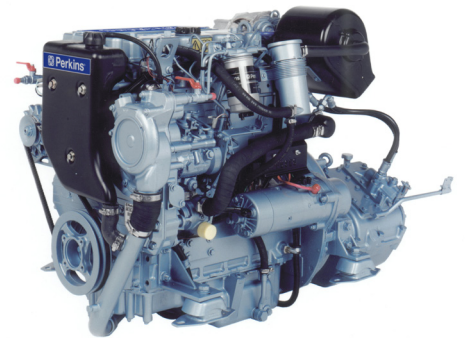

M115T



M92

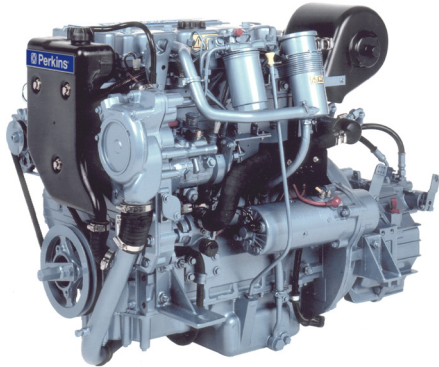

M185C

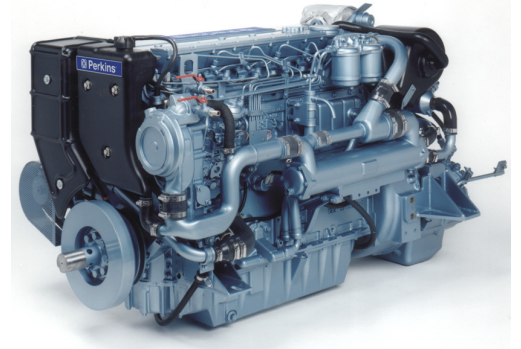

M130C/M135

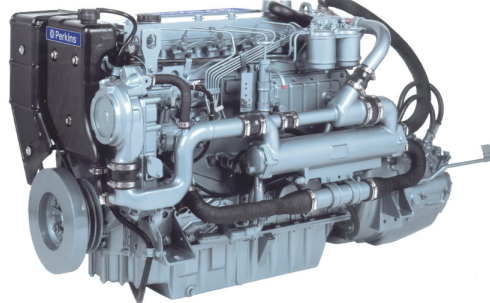

M265Ti/M300Ti

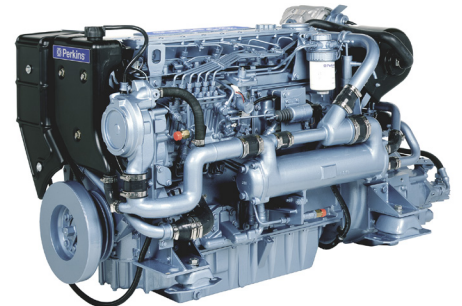

M215C/225Ti

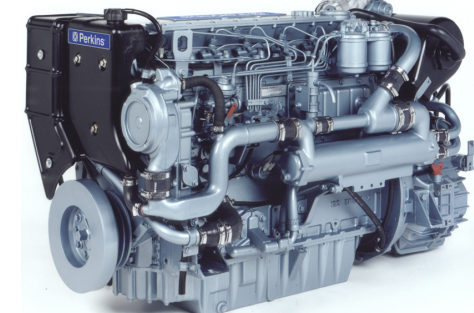

Perkins Marine Engines Installation Manual

- M300Ti** **6 Cylinder turbocharged, intercooled, diesel engine for pleasure boat applications**
- M265Ti** **6 Cylinder turbocharged, intercooled, diesel engine for pleasure boat applications**
- M225Ti** **6 Cylinder turbocharged, intercooled, diesel engine for pleasure boat applications**
- M215C** **6 Cylinder turbocharged, intercooled, diesel engine for commercial applications**
- M185C** **6 Cylinder turbocharged, intercooled, diesel engine for commercial applications**
- M135** **6 Cylinder naturally aspirated, diesel engine for pleasure boat applications**
- M130C** **6 Cylinder naturally aspirated, diesel engine for commercial applications**
- M115T** **4 Cylinder turbocharged diesel engine for all applications**
- M92** **4 Cylinder naturally aspirated diesel engine for all applications**
- M92B** **4 Cylinder naturally aspirated diesel engine for all applications**

This page is intentionally blank.

Contents

| | |
|--|-----------|
| Location of Engine Installation Points | 1 |
| 1 Engine Mounting | 3 |
| 1.1 Installation Angles | 3 |
| 1.2 Engine Mounting Brackets..... | 4 |
| 1.3 Flexible Engine Mounts..... | 5 |
| 1.4 Engine Bearers..... | 6 |
| 2 Propeller Shafts and Couplings | 7 |
| 2.1 Propeller Shafts | 7 |
| 2.2 Gearbox Output Couplings | 8 |
| 3 Exhaust Systems..... | 11 |
| 3.1 Wet Systems..... | 11 |
| 3.2 Dry Systems | 13 |
| 3.3 Part Dry, Part Wet Systems | 20 |
| 3.4 Water Lift Systems..... | 20 |
| 4 Engine Room Ventilation | 23 |
| 5 Engine Cooling Systems | 25 |
| 5.1 Raw Water Systems | 25 |
| 5.2 Keel Cooling Statement: M300Ti and M265Ti Engines - keel cooling is not offered with these models. | 27 |
| 5.3 Keel Cooling System: M225Ti, M215C and M185C Engines | 27 |
| 5.4 Keel Cooling System: M135 and M130C Engine | 28 |
| 5.5 Keel Cooling System: M115T M92 and M92B engine | 29 |
| 6 Fuel Systems | 33 |
| 6.1 Fuel Connections..... | 33 |
| 7 Engine Electrical Systems..... | 37 |
| 7.1 Engine Wiring Looms | 37 |
| 7.2 Fuse board..... | 43 |
| Inverter/Converter Fitting Instructions | 44 |
| 7.4 Interconnecting Cable | 45 |
| 7.5 Instrument Panels..... | 47 |
| 7.6 Battery and Starter Cables..... | 52 |
| 7.7 Zinc Anode bonding system..... | 53 |

| | |
|--|-----------|
| 8 Engine Controls..... | 57 |
| 8.1 M300Ti, and M265Ti Engines | 57 |
| 8.2 M225Ti, M215C and M185C Engines | 58 |
| 8.3 M135 and M130C Engines..... | 59 |
| 8.4 M115T and M92 Engines..... | 60 |
| 8.5 M92B Engines | 61 |
| 9 Provision for Power Take-off..... | 63 |
| 9.1 Axial Drives | 64 |
| 9.2 Belt Drives | 64 |
| 9.3 PTO Fitting Instructions | 65 |
| 9.4 Electro Mechanical Bilge Pump..... | 66 |
| 10 Calorifier and Block Heater Connections..... | 67 |
| 10.1 Calorifier | 67 |
| 10.2 Block Heater - for 6 cylinder engine models | 69 |
| 11 Reference Data..... | 71 |
| 11.1 M300Ti and M265Ti Engines | 71 |
| 11.2 M225Ti, M215C and M185C Engines | 74 |
| 11.3 M135, and M130C Engines | 77 |
| 11.4 M115T, and M92 Engines | 80 |
| 11.5 M92B Engines | 83 |



Location of Engine Installation Points

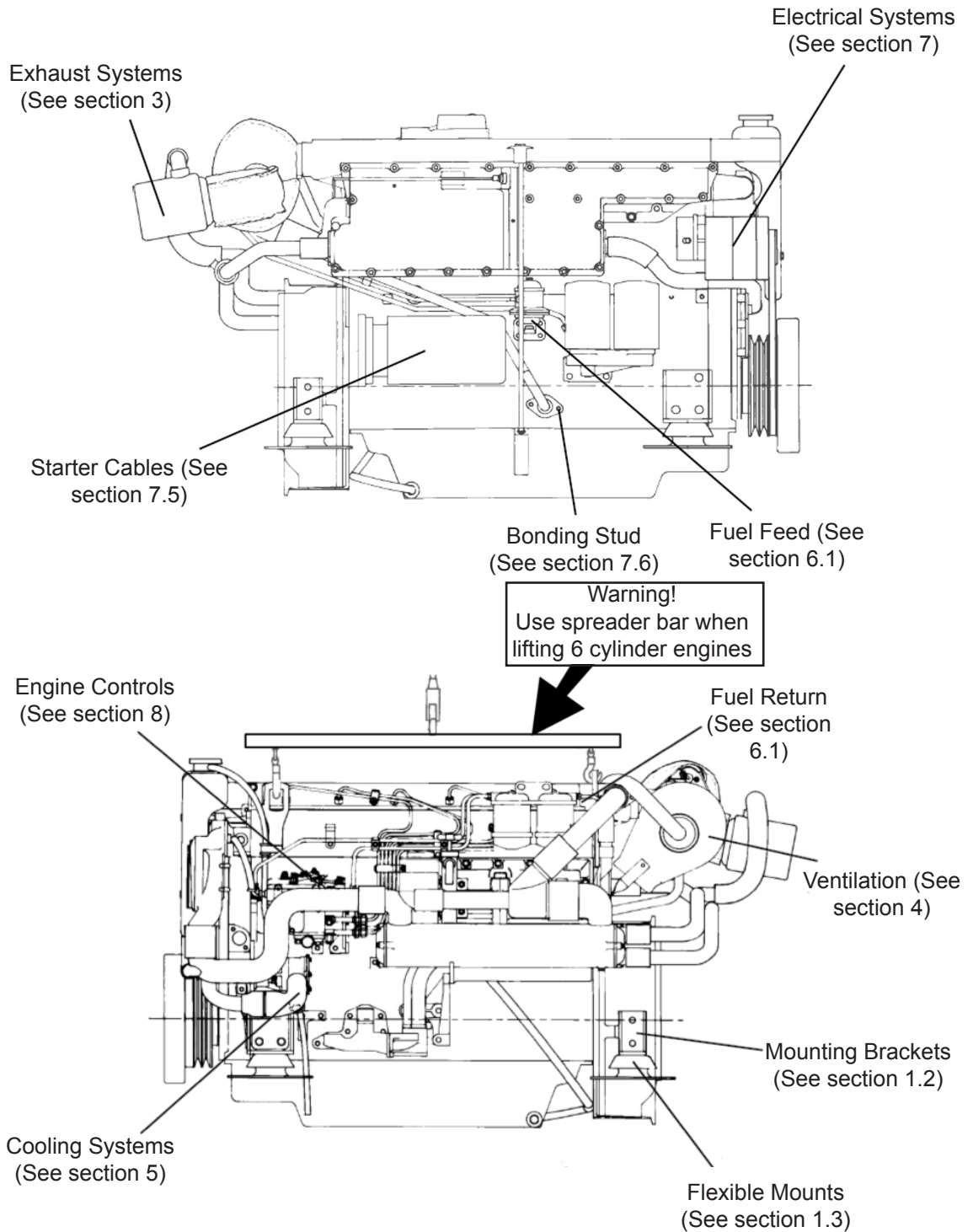

Engine side views

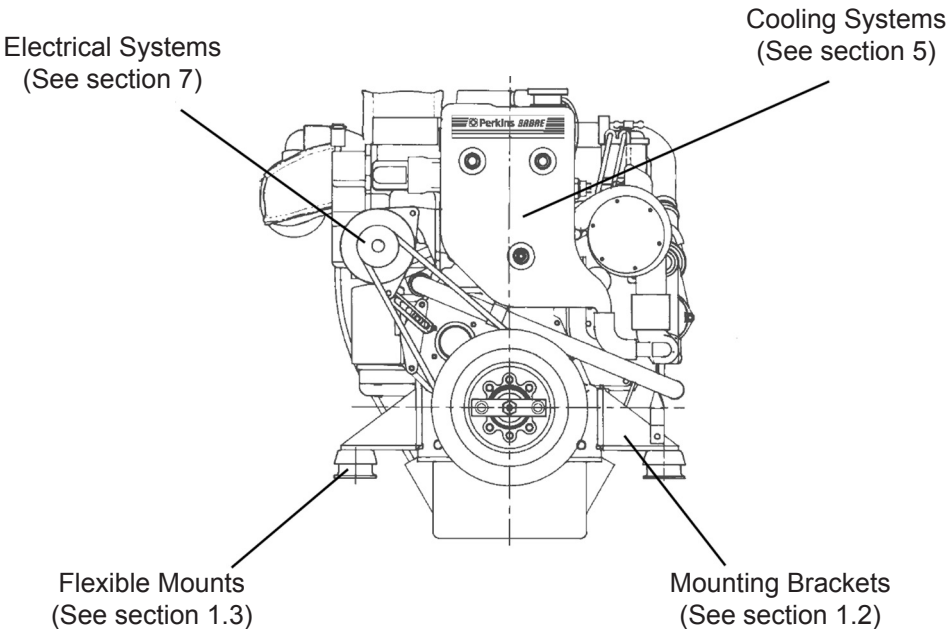
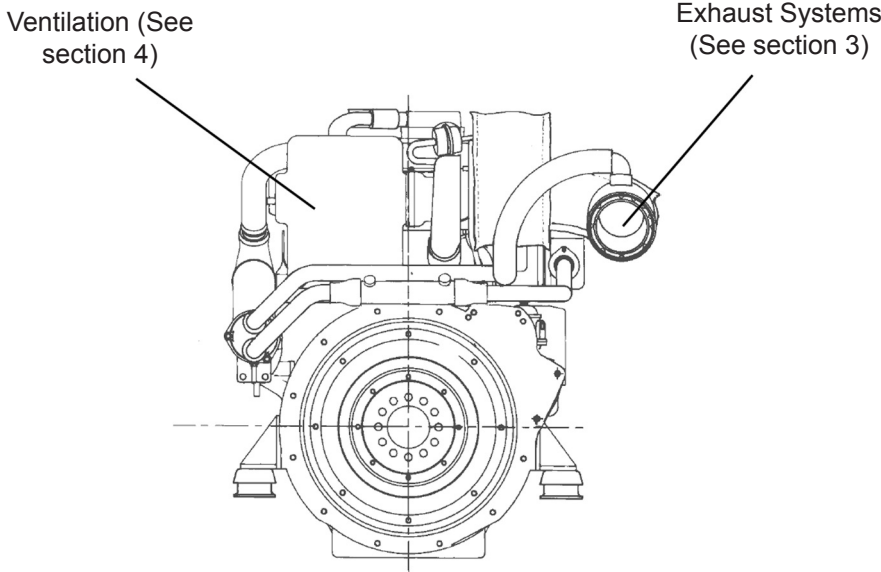

Engine end views

Engine Mounting

1.1 Installation Angles

(a) The engine is intended to be mounted so that the cylinders are vertical, when viewed from ahead or astern (figure 1). The heel angles that are permissible in service are shown in figure 2a for 6 cylinder models, and 2b for 4 cylinder models.

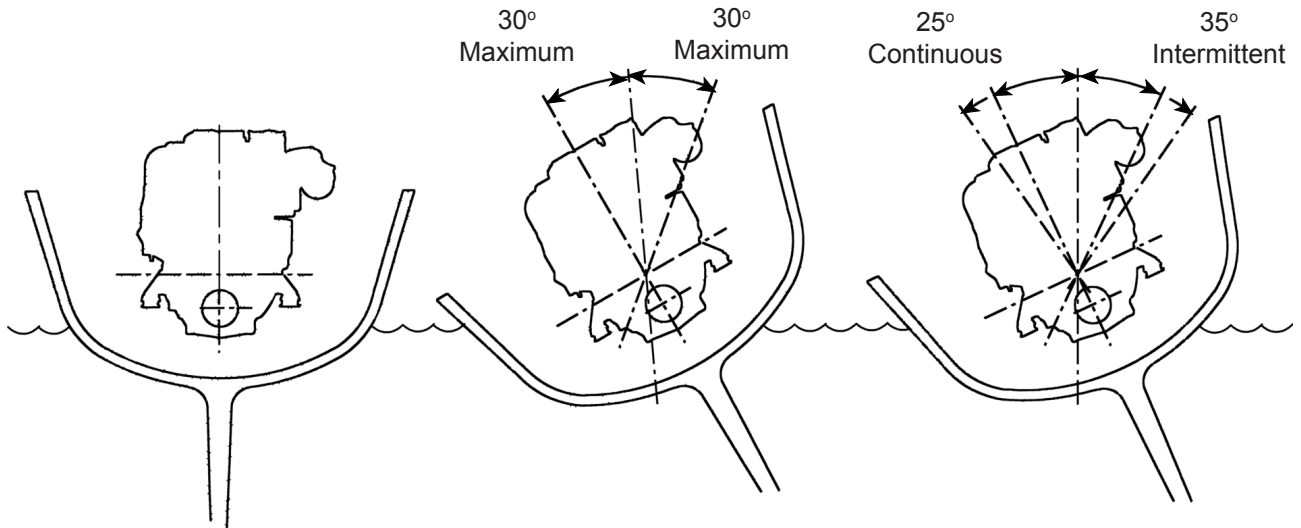

Figure 1 - Vertical installation.

Figure 2a - Acceptable heel angle for 6 cylinder models.

Figure 2b - Acceptable heel angle for 4 cylinder models.

(b) In standard form all engine models are suitable for installation so that in side view the crankshaft is 'flywheel down' from a minimum of 3° to a maximum of 17°. An allowance has been made for an additional 3° rise to occur in service, when climbing waves or on to the plane.



Figure 3 - When in standard form all engine models may be installed 'flywheel down' from a minimum of 3° to a maximum of 17°.

(c) A kit of parts is available to modify 6 cylinder models (only) so that they are suitable for installation with the flywheel end of the crankshaft above the pulley end by up to 5°. An allowance has been made for an additional 3° rise to occur in service, when climbing waves or on to the plane.

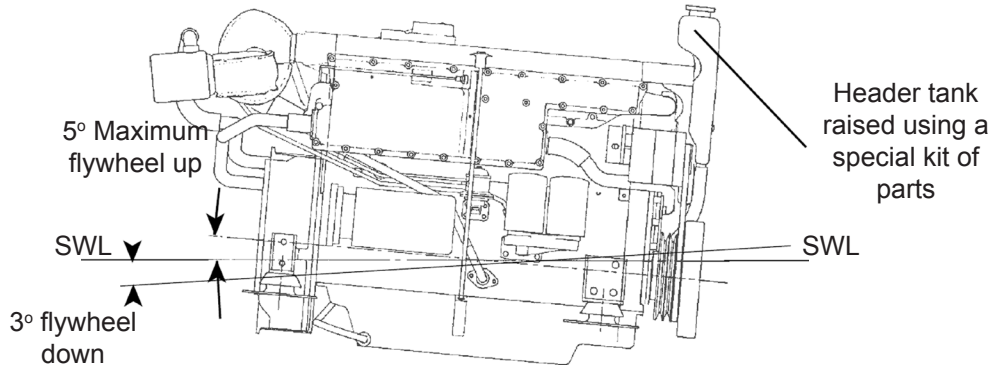

Figure 4 - Six cylinder models may be installed in a horizontal or nose down attitude if a special kit of parts is fitted, to raise the header

1.2 Engine Mounting Brackets

The standard brackets, provide mounting points which are 76mm (3 in.) below, and parallel with, the crankshaft centre line. The brackets may be used to mount the engine directly on the engine bearers, but for all applications it is recommended that flexible engine mounts are used.

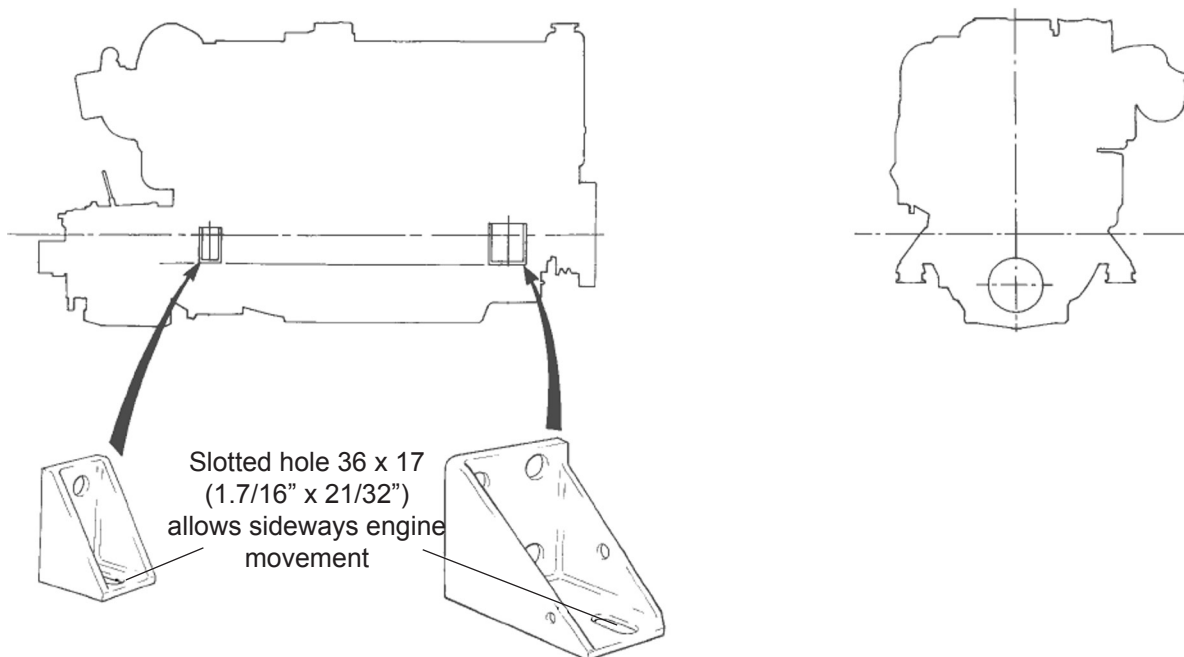

Figure 5 - Typical engine mounting brackets - refer to installation drawings for specific applications.

The holes for the holding down bolts are slotted, to allow for some movement during the final stages of alignment. Where fine alignment is not necessary, for example when a flexibly jointed drive shaft is used, the bolts on all four corners of the engine should be positioned at the end of the slot - all either fully in or fully out. This will provide additional security in the fixing arrangements.

1.3 Flexible Engine Mounts

It is recommended that flexible engine mounts should be used for all applications. The principal purpose of the mounts is to reduce the transmission of vibration from the engine to the hull, but another valuable advantage is that the mountings reduce the shock transmitted from the hull to the engine under adverse weather conditions and also prevent the engine being inadvertently used as a structural part of the boat, due to hull flexure, a function the engine will not satisfactorily fulfil.

Figure 6 shows the leading dimensions of the flexible engine mount which is satisfactory for most applications.

Engines used with unusual drive arrangements, such as 'V' drives when integral with the engine unit, pose special mounting problems and recommendations as to the most suitable mounting arrangement can be made for specific applications.

Where transmission ratios in excess of 2.5:1 are employed, or where extreme service conditions can be expected, (e.g. fast rescue boats) the standard mount should not be used, and a recommendation should be obtained for the specific application.

Installation drawings are available showing the preferred mounting arrangements when using a variety of gearboxes.

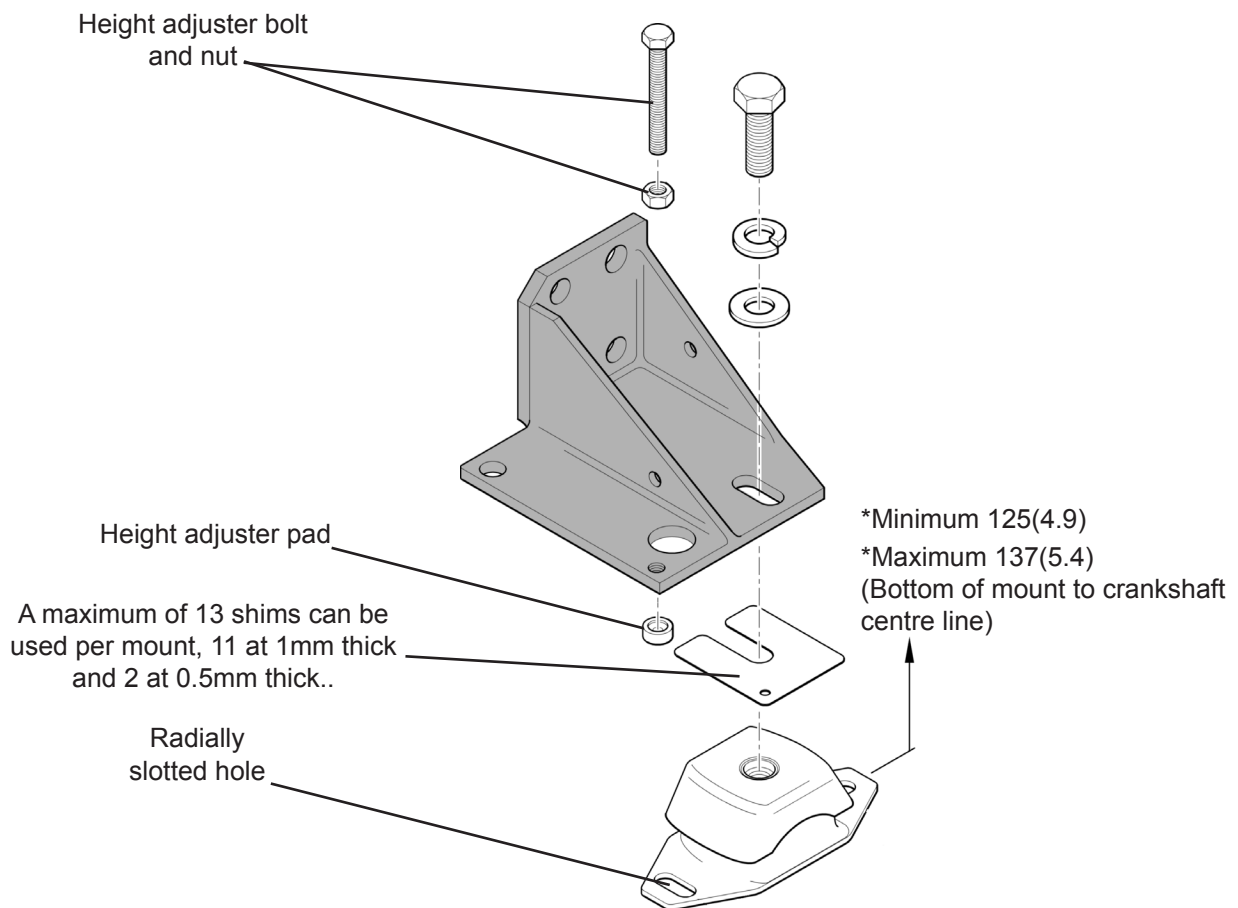

Dimensions: mm(inches)

*Dimensions given are for the mount in the unloaded condition

Figure 6 - Typical flexible engine mount - refer to installation drawing for specific applications.

1.4 Engine Bearers

The materials and methods of construction of engine bearers which have proved to be satisfactory in service vary to such an extent that it is difficult to lay down universal guide lines. However, as a rough guide it can be said the engine bearers should be capable of supporting a static load of about eight times the weight of the engine, to cater for the effects of rough seas.

The bearers should be cross connected to give lateral rigidity, in order to maintain the shaft alignment and to prevent twisting and racking forces being applied to the engine.

To enable minimum shaft centre distances to be achieved in a twin installation, a common centre bearer supporting the inner mountings of both engines is sometimes used as shown in figure 7. By this method shaft centres down to 690mm (27") may be adopted, but wider spacing is desirable.

The shaft centres could be theoretically reduced further, but this would result in the engine accessibility becoming very restricted, and it would be impossible to carry out service operations. It should be noted that if minimum shaft centres are to be adopted, space must be left in front of and behind the engine to provide access. A minimum clearance on all sides will mean that the engine cannot be serviced!

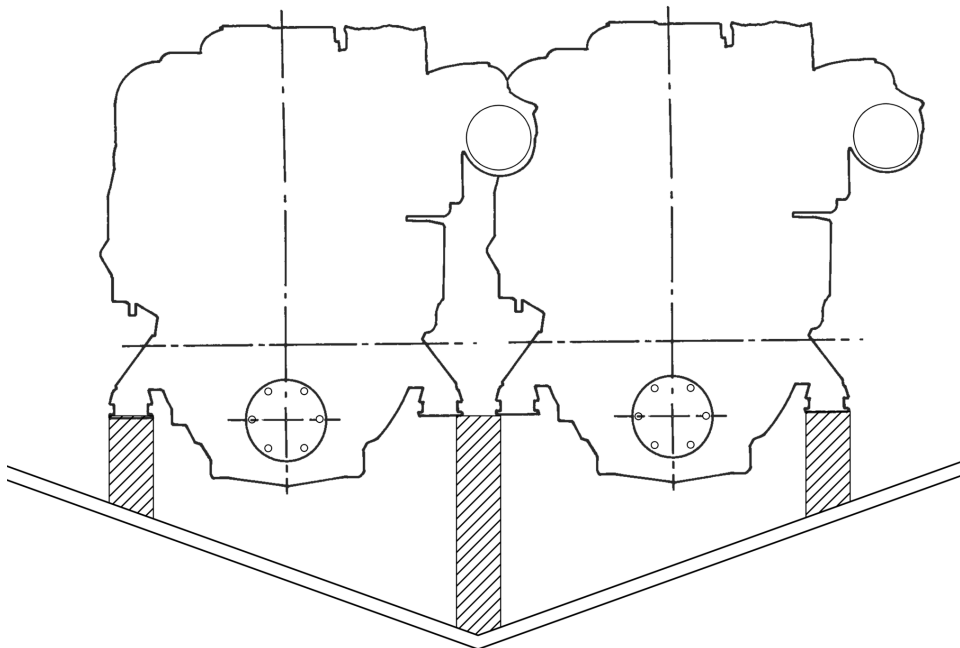

Figure 7 - Illustration of the closest practicable engine spacing.
With this arrangement access space must be provided ahead and behind the engines for servicing.

Propeller Shafts and Couplings

2.1 Propeller Shafts

It is recommended that all engines are mounted on flexible mountings, which will reduce the transmission of noise and vibration, and will prevent hull movements resulting in forces being applied to the engine.

The responsibility for the design and installation of the transmission system connected to the marine gearbox lies with the boat designer, the boat builder, the naval architect or the engine installer. It is recommended that a Torsional Vibration Analysis (TVA) is carried out on the complete drive system. Mass Elastic Data on the engine can be provided on request from Wimborne Marine Power Centre. The following observations are offered, to show some of the systems currently in use.

Figure 1 shows a simple arrangement, where the propeller shaft is supported only by the gearbox coupling and an outboard rubber bearing at the propeller end. Entry of water into the boat is prevented by a shaft seal, which must be flexibly mounted to allow for engine movement. A flexible shaft coupling is fitted to the gearbox coupling, to allow momentary angular misalignment in operation.

This system is only suitable for applications where the speed, diameter, and unsupported length of the propeller shaft will not induce 'whirling' (i.e. the centrifugal force generated by the speed of rotation is not sufficient to bend the shaft into a bow shape).

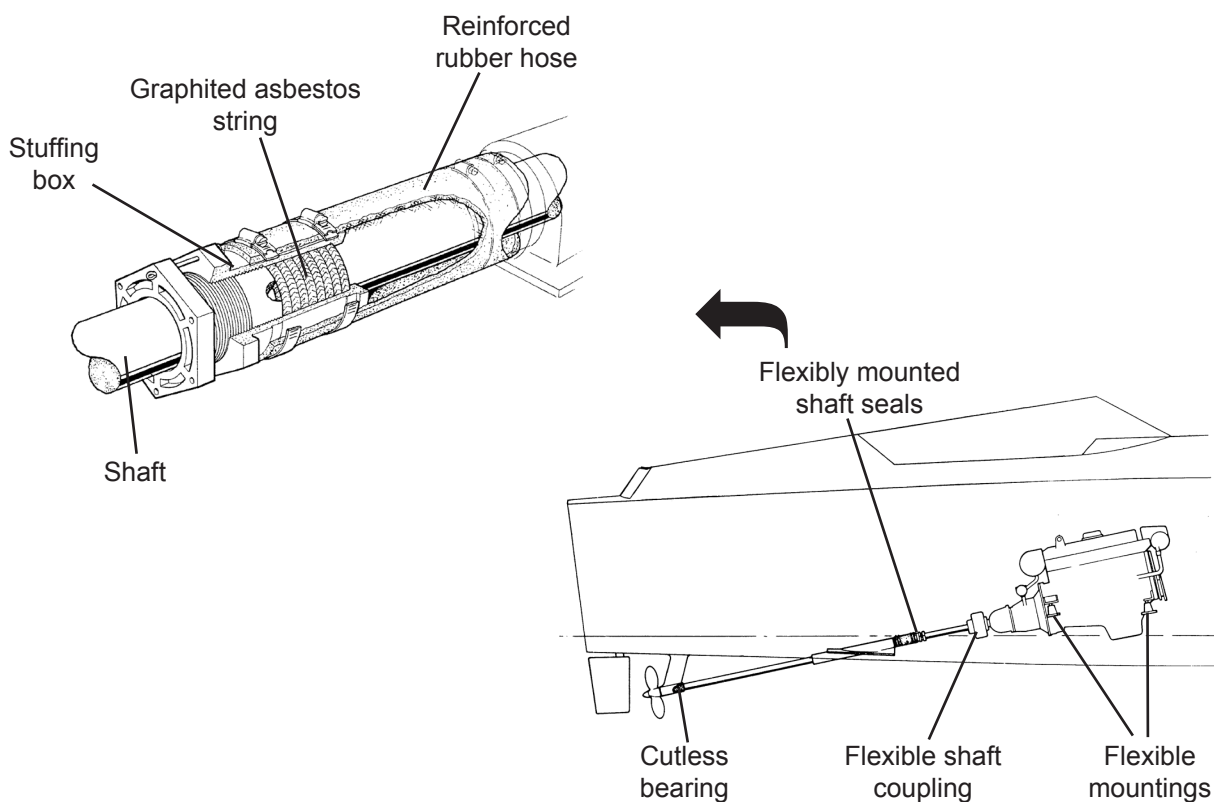

Where the propeller shaft length is such that it cannot be simply supported by the gearbox coupling and 'P' bracket, without the risk of whirling, the arrangement shown in figure 2 may be adopted.

In this case one or more additional bearings are included in the shaft log, and flexible shaft couplings (which will accept thrust) are used to permit the engine to move on the flexible mountings.

A variation of this system is to use a thrust block (bearing) at the point where the shaft emerges from the log into the engine room, together with constant velocity joints at each end of the short shaft connected to the gearbox coupling.

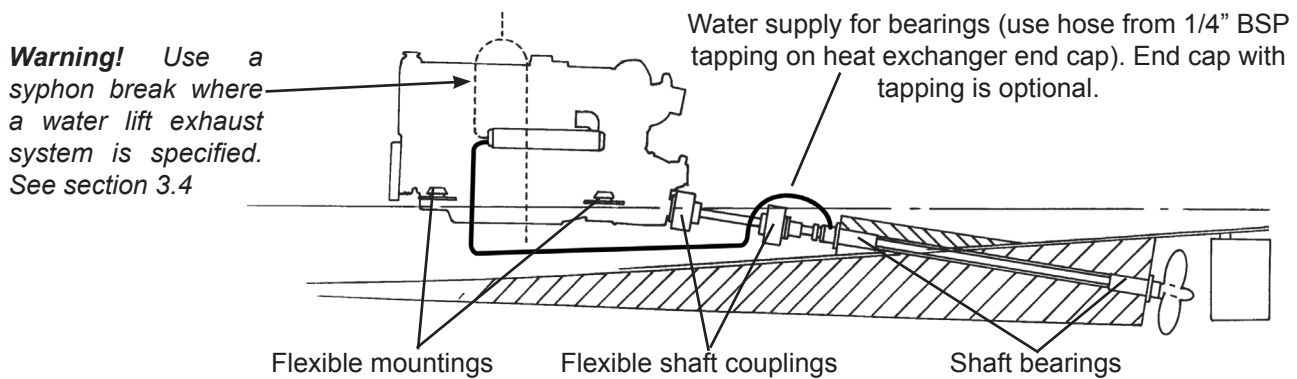

Figure 2 - Alternative shaft arrangement

2.2 Gearbox Output Couplings

Flanged propeller shaft couplings, to suit the gearbox output couplings offered by the many gearbox manufacturers, come in a number of different shapes and sizes, and a variety of methods can be employed to grip the propeller shaft.

A traditional and sound method is to provide the same taper at both ends of the propeller shaft, so that the gearbox coupling can be machined at the same time as the propeller. This system is still commonly employed, particularly where high thrusts and heavy boats are involved. If the shaft becomes worn it can be turned end for end, and re-used at minimum cost.

As an alternative to the above procedure the method shown in figure 3 may be adopted. Flanged couplings supplied with Twin Disc gearboxes are intended for this system. The shaft is gripped by means of a split coupling, with a key to provide positive drive, and a dowel pin to eliminate the possibility of the shaft being drawn out of the coupling when going astern.

For lighter duty applications the system shown on figure 4 may be employed, utilising the flanged couplings supplied with Hurth gearboxes. In this case ahead thrust is taken directly by the gearbox output shaft, as the propeller shaft is butted against it. The shaft is secured by means of two half dog setscrews which also prevent loss of the shaft when going astern. Positive drive is provided by a key.

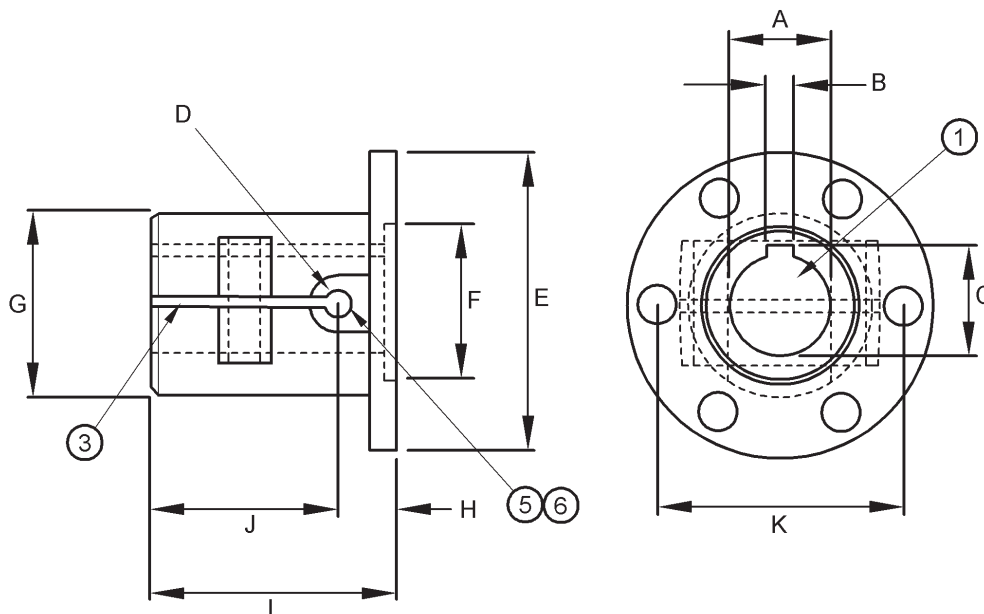

| Dimensions in inches | | | | | | | | | | |
|----------------------|------|------|---------------------------------|------|-----|-----|------|------|------|------|
| A | B | C | D | E | F | G | H | I | J | K |
| 1.25 | 0.31 | 1.39 | Drill 15/32 Ream 0.5005-0 | 5.75 | 3.0 | 3.4 | 1.12 | 4.25 | 3.12 | 4.76 |
| 1.38 | 0.31 | 1.52 | | | | | | | | |
| 1.50 | 0.38 | 1.67 | | | | | | | | |
| 1.75 | 0.44 | 1.95 | | | | | | | | |
| 2.00 | 0.50 | 2.23 | | | | | | | | |

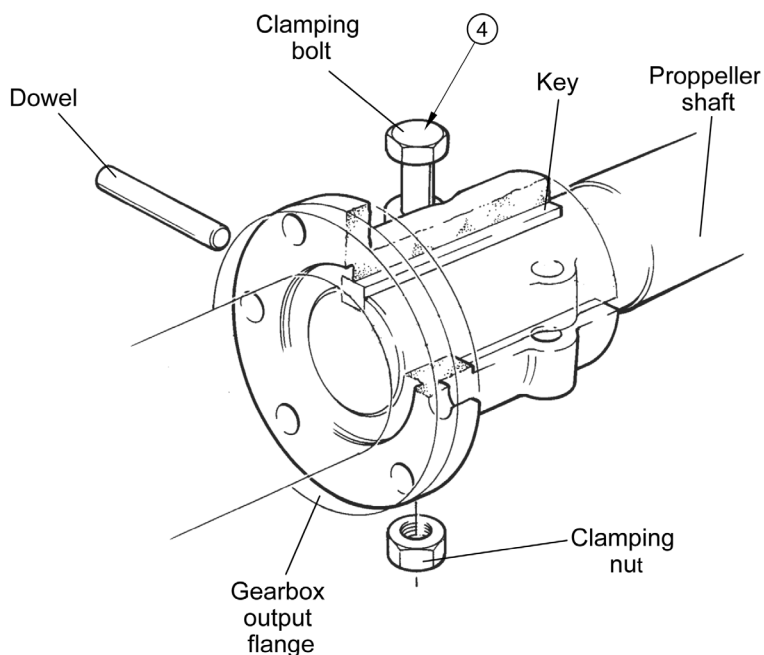

- Machining Procedure**
1. Bore to size (dimension 'A').
 2. Broach keyway 4.0" long (dimension 'B').
 3. Split, 0.135 Max. width (dimension 'J').
 4. Clamp the coupling to the propeller shaft in the position shown.
 5. Drill 15/32" Diameter hole through the propeller shaft and far side of the coupling, using the starter hole (dimension 'D').
 6. 0.5005-0.4990 Diameter ream through both the coupling and shaft.
 7. Dismantle and clean, then assemble.

Figure 3 - Twin Disc gearbox couplings

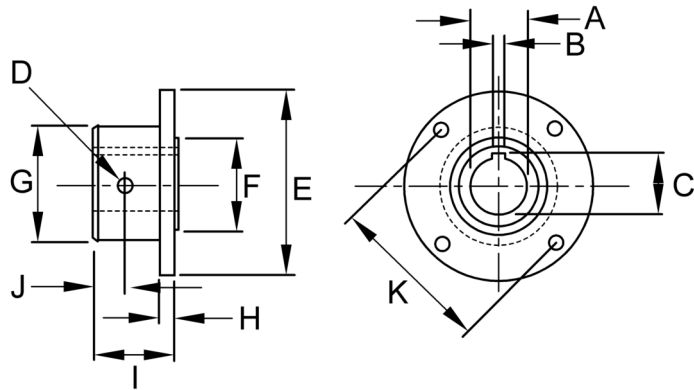

| Dimensions in inches | | | | | | | | | | |
|----------------------|------|------|------------|------|------|------|------|------|------|------|
| A | B | C | D | E | F | G | H | I | J | K |
| 1.00 | 0.25 | 1.12 | 3/8 UNC | 5.00 | 2.50 | 3.16 | 0.38 | 2.16 | 0.88 | 4.25 |
| 1.12 | 0.25 | 1.24 | | | | | | | | |
| 1.25 | 0.31 | 1.39 | | | | | | | | |
| 1.38 | 0.31 | 1.52 | | | | | | | | |
| 1.50 | 0.38 | 1.67 | | | | | | | | |
| 1.75 | 0.44 | 1.95 | | | | | | | | |
| 2.00 | 0.50 | 2.23 | | | | | | | | |
| 2.25 | 0.56 | 2.50 | | | | | | | | |

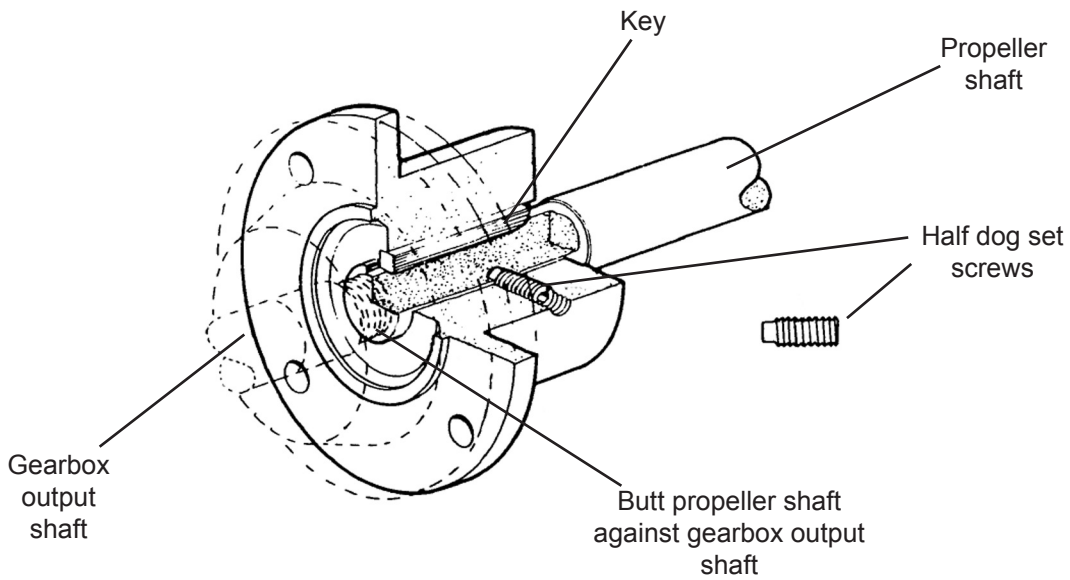

Figure 4 - Hurth gearbox couplings

Exhaust Systems

A wide range of exhaust components are available for use with all types of exhaust system. The components are designed to connect together, allowing complex systems to be built from stock items, to suit most installations.

Caution: In all types of exhaust system the exhaust back pressure must not exceed 10 kPa of mercury, (except the M92B which is 15 kPa), when measured within 305mm (12 inches) of the exhaust outlet from the engine.

3.1 Wet Systems

Wet exhaust systems, where the raw water used to circulate through the heat exchangers on the engine is finally dumped into the exhaust pipe to cool the exhaust gases, are the most common choice for small craft. Their principal advantage is that a rubber exhaust hose may be used, with a fairly low surface temperature, which presents no risk of fire.

A general arrangement for such a system is shown on Figure 1. In many cases the exhaust outlet passes through the transom, just above the waterline. It will be seen that a minimum fall of 5° is required, and that the point of water injection must be at least 8 inches above the waterline, although the actual height necessary for a particular boat can only be decided in the light of the exhaust system design, and the pitch and roll which may be encountered in service.

Caution: It is essential that the exhaust system is designed so that water from the exhaust does not enter the engine under any conceivable operational condition.

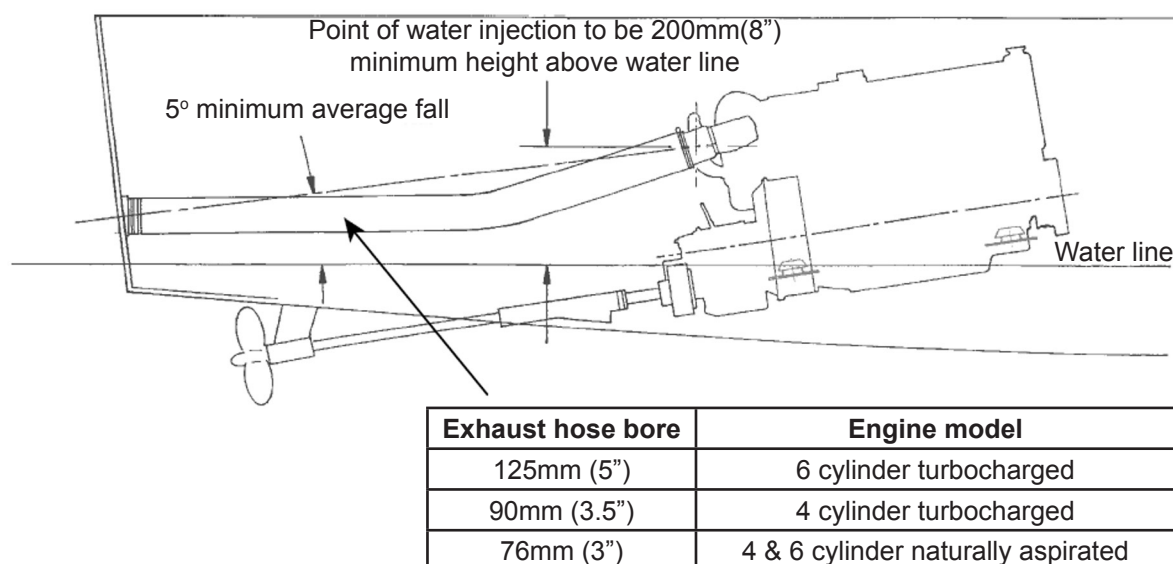

Figure 1 - General exhaust arrangement.

In order to achieve sufficient height above the waterline it may be necessary to use the system shown in Figure 2. This also enables the two elbows to be rotated relative to each other to allow the exhaust hose to run towards the side of the boat. The arrangement shown raises the exhaust height above the turbocharger outlet by about 230mm (9 inches) - greater heights can be achieved if necessary by using the arrangement described in Section 3.3.

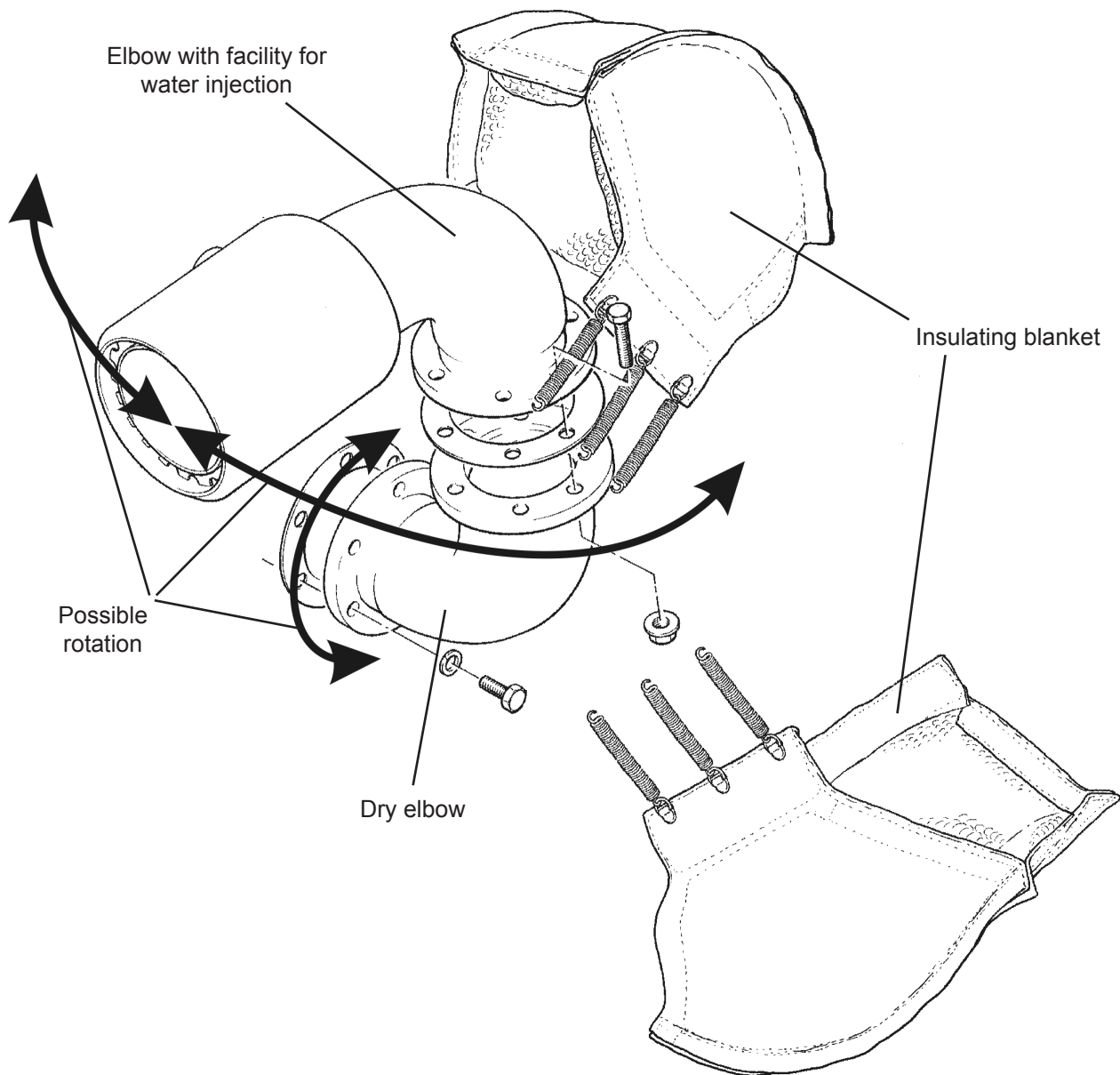

Figure 2 - High rise exhaust elbow.

Due consideration must be given to providing flexibility in the exhaust hose, particularly if the engine is flexibly mounted. Where the exhaust hose must pass through a bulkhead immediately behind the engine it is preferable that the arrangement shown in Figure 3 is adopted, using rubber bellows to provide flexibility. Note that the bellows should be in an unstrained condition when fitted.

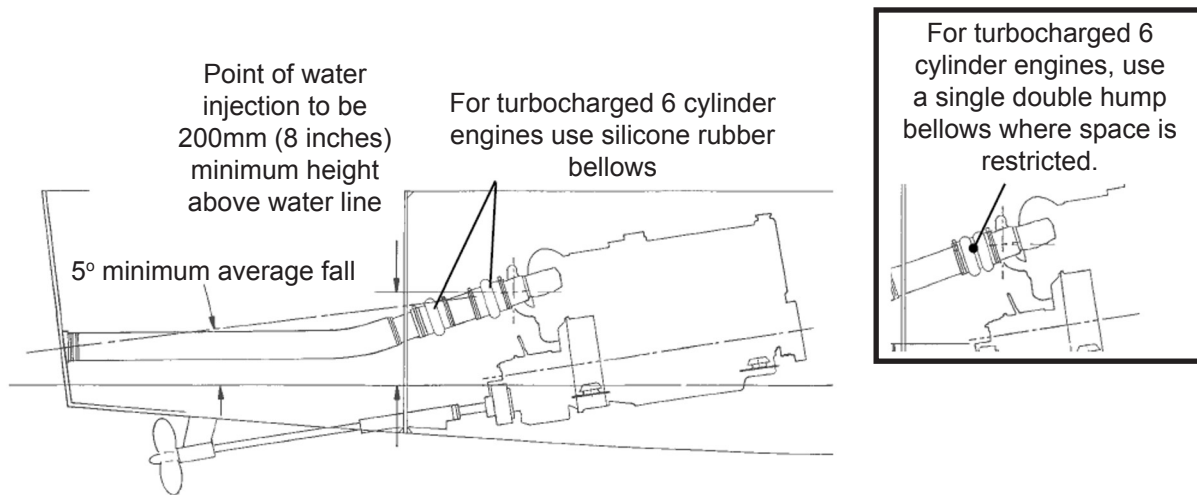

Figure 3 - Movement of the engine on the flexible mounts must not be restricted by the exhaust hose. Use rubber bellows as shown where space is restricted.

3.2 Dry Systems

Dry exhaust systems for marine installations need careful design to minimize the disadvantages of enclosing components that are at a high temperature in confined spaces.

The first part of a dry system should include a flexible connection so that excessive weight is not carried by the connection to the engine. Connections of the stainless steel bellows type are suitable, but care must be taken to ensure that they are only required to accommodate movements that do not involve twisting the ends of the bellows relative to each other.

The remainder of the exhaust system should be well insulated to avoid fire risk.

If there is a long exhaust run which gains height as it leaves the engine, it may be necessary to incorporate a trap to collect condensate and allow it to be drained.

Figures 4, 5, 6, 7 & 8 show typical systems. The minimum bore of the exhaust pipe should be 76mm (3 inches) for turbocharged engines, 63mm (2.5 inches) for naturally aspirated engines.

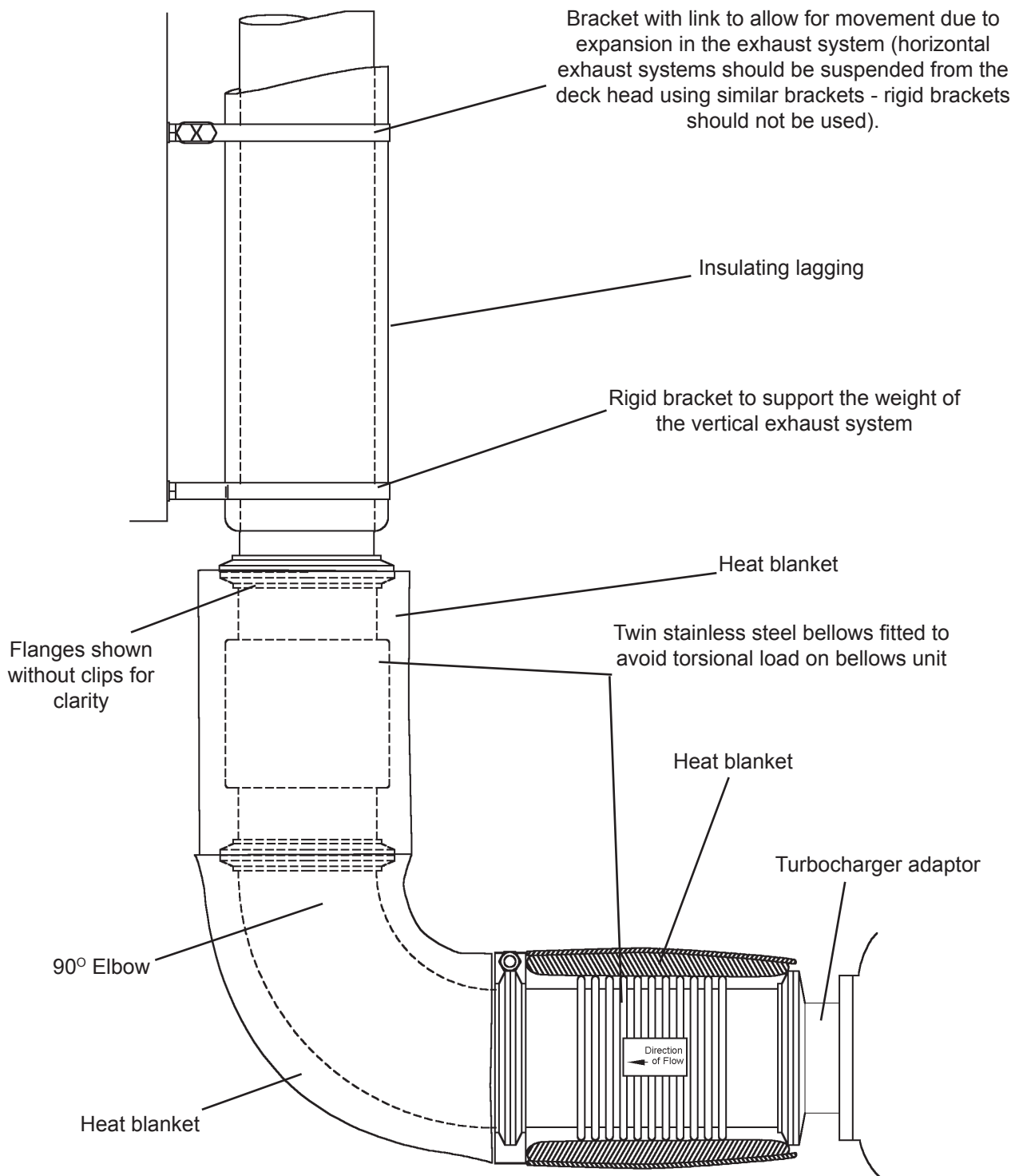

Figure 4 - Dry Exhaust System Features - M265Ti, M300Ti.

Note: When fitted, the bellows units should be in an unstrained condition so that the full bellows movement is available to absorb expansion and engine movement.

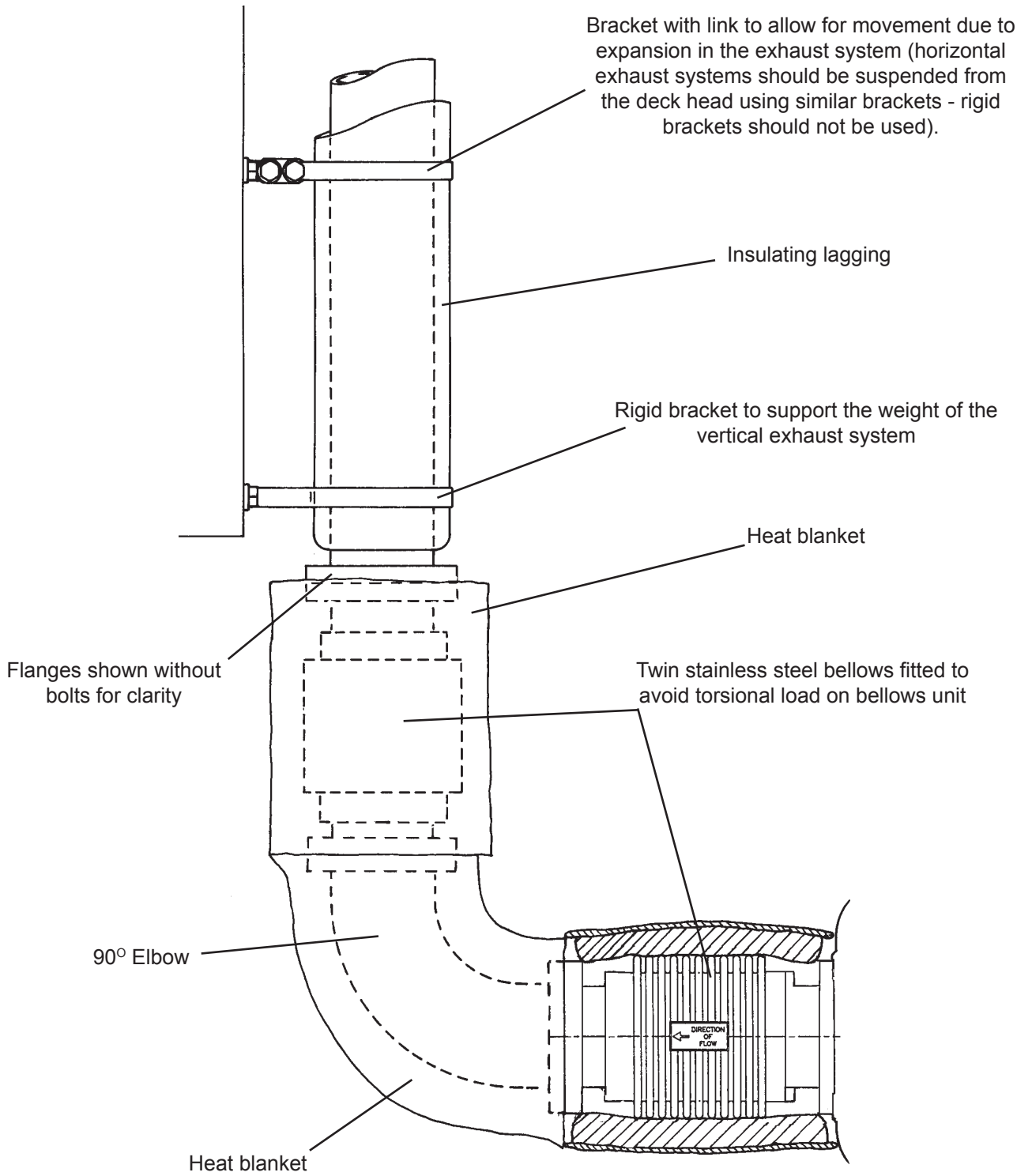

Figure 5 - Dry Exhaust System Features - M185C, M215C, M225Ti, M265Ti & M300Ti

Note: When fitted, the bellows units should be in an unstrained condition so that the full bellows movement is available to absorb expansion and engine movement.

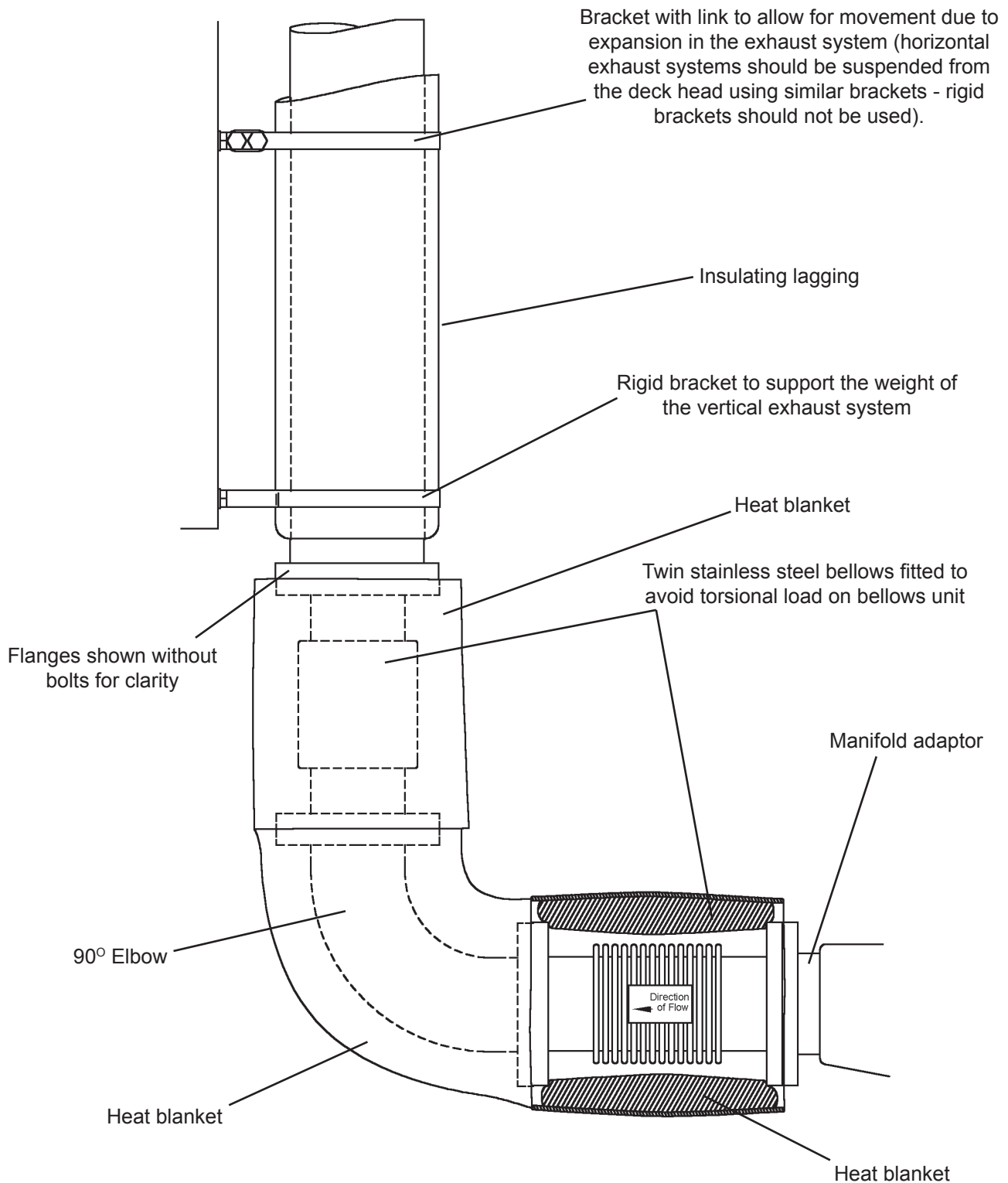

Figure 6 - Dry Exhaust System Features - M130C, M135.

Note: When fitted, the bellows units should be in an unstrained condition so that the full bellows movement is available to absorb expansion and engine movement.

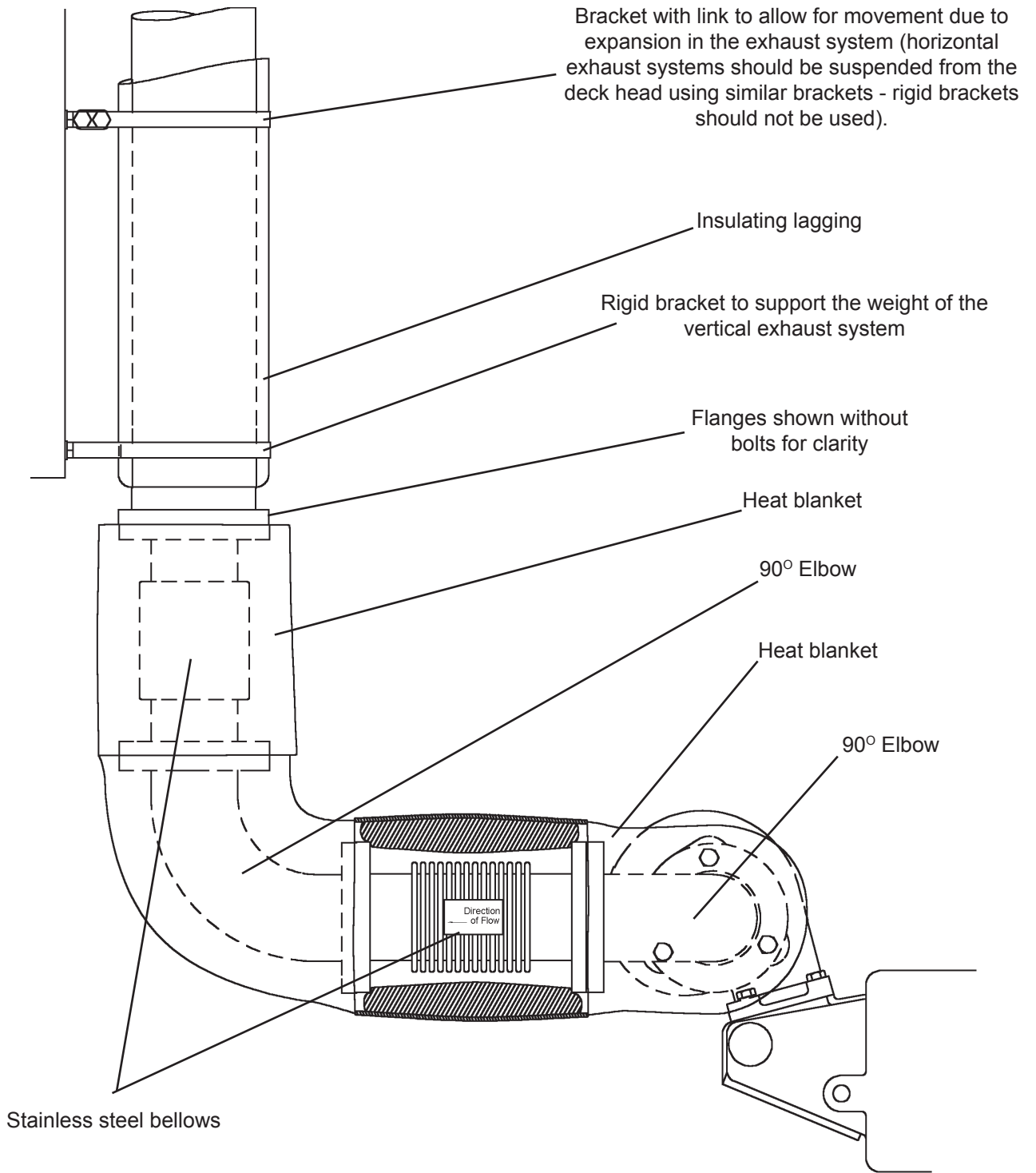

Figure 7 - Dry Exhaust System Features - M115T.

Note: When fitted, the bellows units should be in an unstrained condition so that the full bellows movement is available to absorb expansion and engine movement.

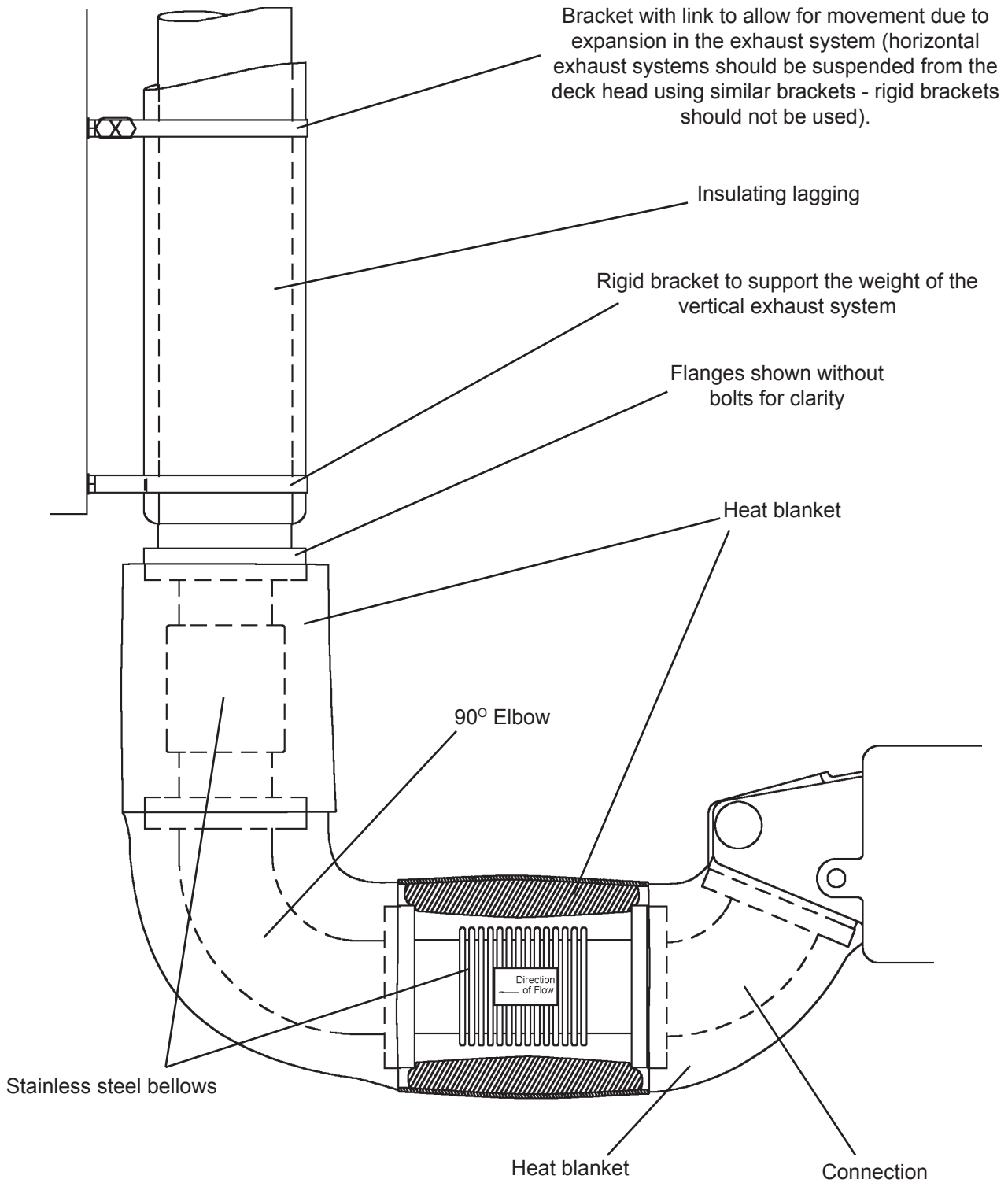

Figure 8 - Dry Exhaust System Features - M92.

Note: When fitted, the bellows units should be in an unstrained condition so that the full bellows movement is available to absorb expansion and engine movement.

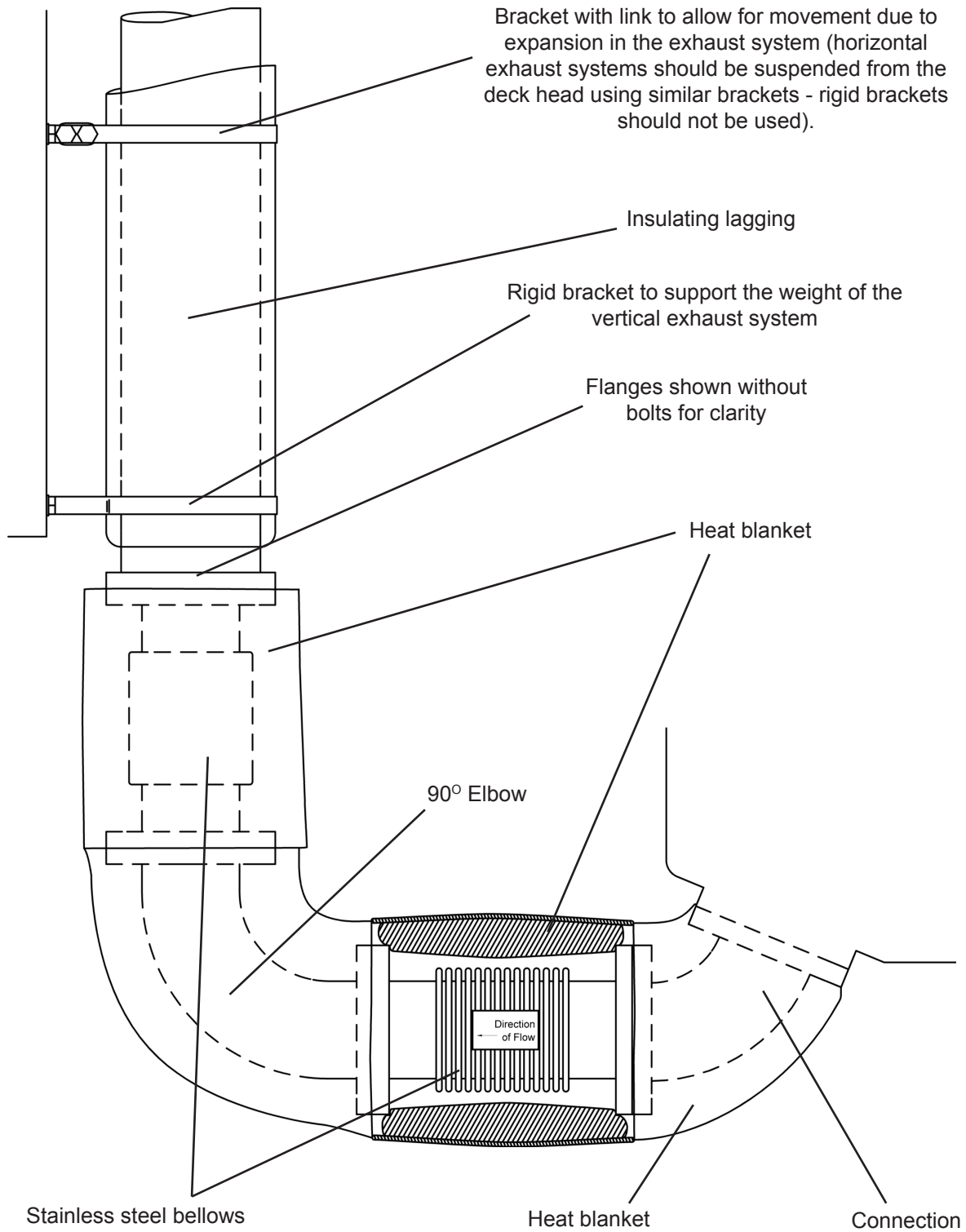

Figure 9 - Dry Exhaust System Features - M92B.

Note: When fitted, the bellows units should be in an unstrained condition so that the full bellows movement is available to absorb expansion and engine movement.

3.3 Part Dry, Part Wet Systems

Even where the engine is mounted well below the waterline the advantages of a wet system can still be gained, providing that water injection takes place at a point sufficiently above the waterline.

In these circumstances the part dry, part wet system shown in Figure 9 can be utilised. The modular exhaust components allow a system to be readily constructed, utilising a tall dry riser, followed by a water injection elbow.

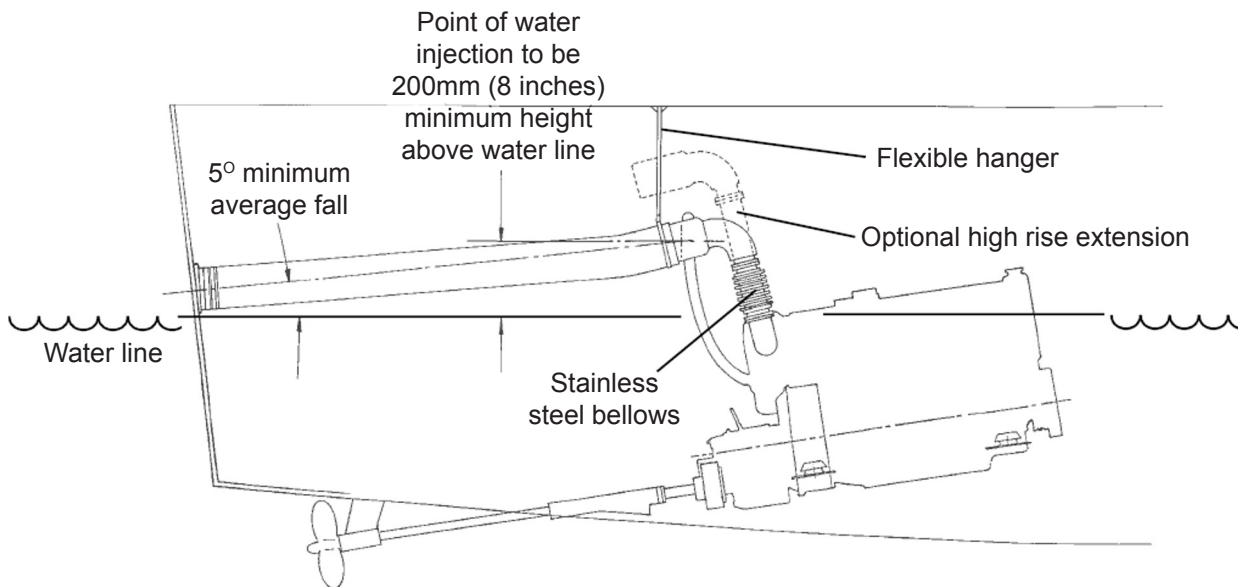

Figure 9 - Part Wet, Part Dry Exhaust System - The illustration shows a turbocharged engine, but the principle also applies to naturally aspirated engines.

3.4 Water Lift Systems

Whenever an engine is mounted with the exhaust outlet at or below the waterline, the exhaust systems shown in 3.2 and 3.3 should first be considered. If the layout of the boat is such that neither are suitable then a water lift system may be appropriate, but note that these systems make engine starting more difficult. (This should only be noticeable at low temperatures.)

Figure 10 shows the main features of such a system, which utilises pressure developed by the exhaust gases to force a mixture of gas and water to a height which may be considerably above the engine. When the engine is stopped the exhaust tank contains the water which falls back from the exhaust riser.

If a proprietary unit is used the manufacturers instructions should be carefully followed, but figure 10 identifies the key features.

Note that the system must meet the requirement for the maximum exhaust back pressure to be not greater than 10 kPa, (except the M92B which is 15kPa), of mercury, measured within 305mm(12 inches) of the turbocharger/ exhaust outlet.

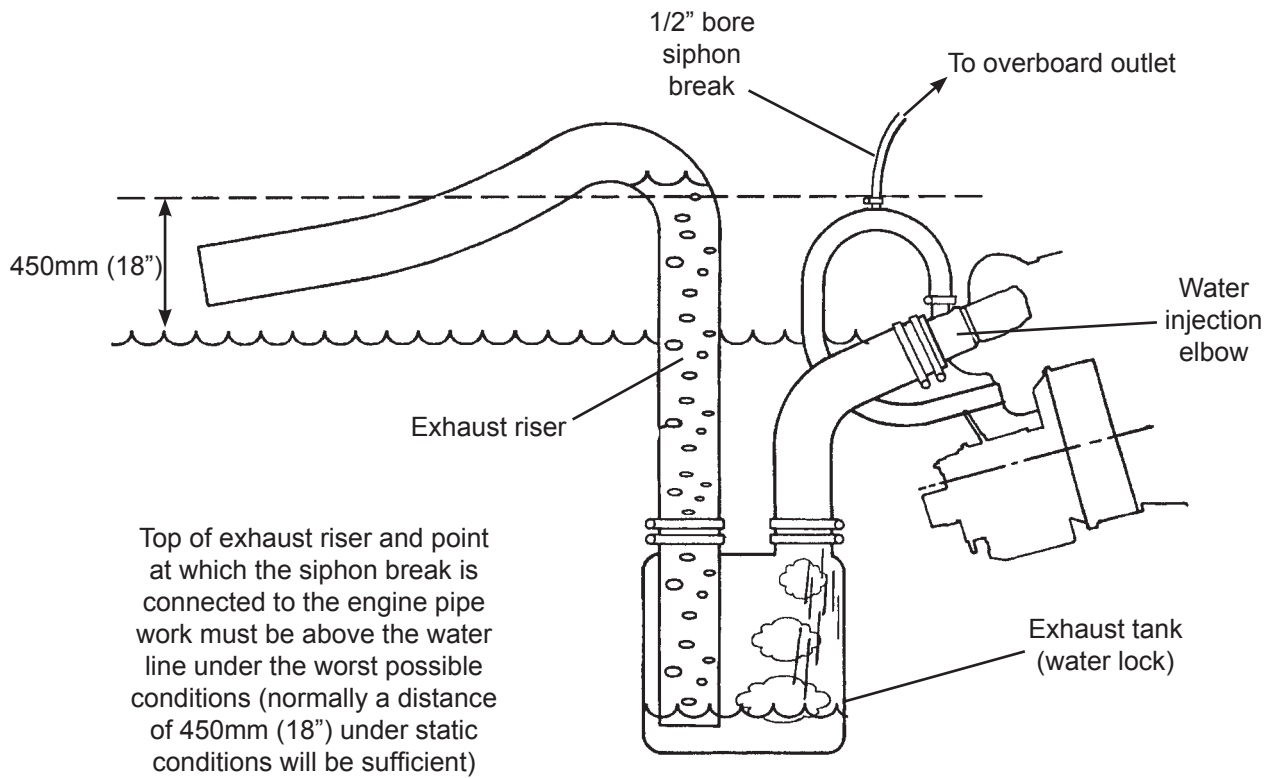

Figure 10 - Water lift system

- a. Minimum volume of exhaust tank should be 3 times the volume of the water in the riser.
- b. The tank should be installed near the centre-line of sailing craft.

Engine Room Ventilation

The engine room must be ventilated for two reasons:

- To supply the engine with air for combustion.
- To provide a flow of air through the engine room to prevent an excessive temperature build up, which may cause components such as the alternator to overheat.

In most applications in temperate climates, the engine will draw air from the engine room. If this is the case then, as a rough guide, it can be taken that every horsepower produced by the engines requires, as a minimum, 0.25 sq.ins. of vent area. If the boat is likely to be used in hot climates, and if engine room ventilation fans are fitted, then a vent area of 0.5 sq.ins. per horsepower should be provided, (see the table below). Wherever possible a flow of air through the engine room should be encouraged by using forward facing intake vents to take advantage of ram airflow, together with other vents to allow hot air to escape.

With an effective ventilation system the engine air intake temperature will be no more than 10 Centigrade degrees higher than the outside air temperature.

| Minimum cross section of air duct per engine | | |
|--|-------------------------|------------------------|
| Model | For hot climates | For temperate climates |
| M300Ti | 900 sq.cm (140 sq. ins) | 450 sq.cm (70 sq.ins) |
| M265Ti | 800 sq.cm (125 sq.ins) | 400 sq.cm (60 sq.ins) |
| M225Ti / M215C / M185C | 600 sq.cm (100 sq.ins) | 300 sq.cm (50 sq.ins) |
| M135 / M130C | 300 sq.cm (50 sq.ins) | 150 sq.cm (25 sq.ins) |
| M115T | 350 sq.cm (54 sq.ins) | 175 sq.cm (27 sq.ins) |
| M92 / M92B | 280 sq.cm (43 sq.ins) | 140 sq.cm (22 sq.ins) |

The air entry vents should be situated where spray is not likely to enter them and some form of water trap is desirable (see figure 1). Preferably the air ducts should reach the engine compartment at the sides of the hull so that water will fall into the bilge.

When the engines are shut down after a run at high output in high ambient temperature conditions, it will be found that very high air temperatures will build up in the engine compartment. In boats with open cockpits this is usually of no real consequence but if the engines are mounted below a wheel house, then unpleasantly warm conditions may result. In these circumstances engine room ventilation fans are beneficial, preferably arranged to exhaust air from over the engine.

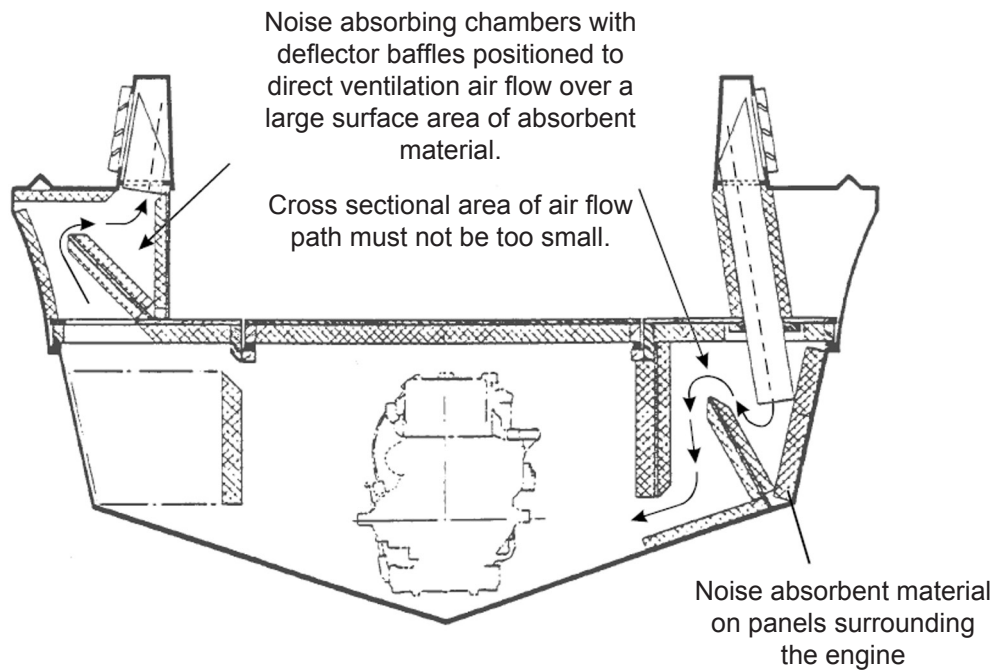

Figure 1 - Example of an engine room ventilation layout.

Note: The air temperature entering the engine should not exceed 52°C (125°F)

Engine Cooling Systems

5.1 Raw Water Systems

A completely separate sea water system should be provided for each engine to prevent a blockage resulting in the need to shut down more than one engine.

The water intake fitting should not project appreciably below the bottom of the hull and it should be situated well clear of other components such as shafts, logs, rudders to prevent flow problems at high speeds. If desired the rear edge of the water intake may be allowed to project more than the front, by no more than 6mm (0.25") to give a slight scoop effect, but if this is done it is necessary to locate the fitting so that it cannot be inadvertently partially rotated.

The intake fittings and pipe work should have a minimum bore of 25mm (1") (see figure 1). Inboard of the intake fitting a sea cock must be provided. This should be of the full flow type giving unobstructed passage to the water in the open position, with a minimum bore of 25mm (1").

Between the intake fitting and the sea water pump on the engine, there should be a strainer which should be easily accessible for routine examination, and should be easily removable.

From the sea water strainer a pipe should be run to the sea water pump inlet connection on the engine (see figure 1). The pipe may either be mainly rigid, of for example copper or cupro-nickel, or flexible, but only flexible hose which is reinforced to prevent collapse should be used. Rubber hose connections in the sea water system should be kept as short as possible and should be reinforced with a minimum of three layers of canvas. The system must be sufficiently flexible to permit the engine to move on its flexible mountings. The sea water pump connection is for hose with a 32mm (1.25") bore.

Care should be taken to use compatible materials in the sea water systems, to prevent excessive electrolytic corrosion. Systems incorporating copper, cupro-nickel, stainless steel Type 316, gun-metal, silver solder, and aluminium brass will generally be satisfactory. Components made from lead, iron, steel, aluminium or its alloys, zinc or magnesium, should be generally avoided.

A typical system is shown in figure 1.

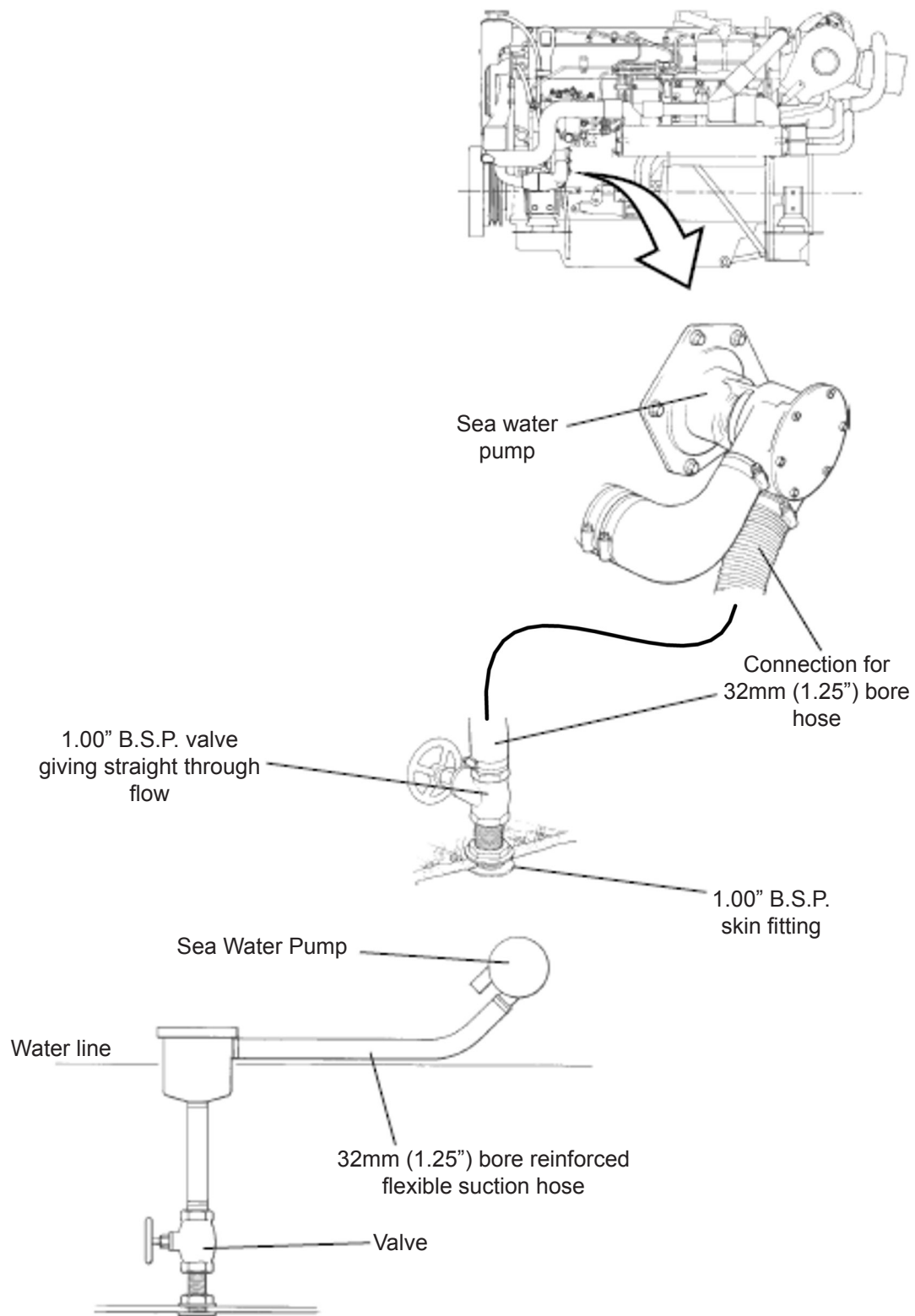

Figure 1 - Sea water intake system.

Note: Where possible mount the strainer so that the top is just above the waterline - to facilitate cleaning.

5.2 Keel Cooling Statement: M300Ti and M265Ti Engines - keel cooling is not offered with these models.

5.3 Keel Cooling System: M225Ti, M215C and M185C Engines

All engine models may be purchased in a form suitable for keel cooling, using two separate coolers, one for the cylinder jacket circuit and one for the intercooler circuit. Figure 2 shows the connections provided for the coolers. The requirements for each section are as follows:

| | M215C/M225Ti | M185C |
|---|-------------------------|--------------------------|
| Cylinder Jacket Circuit Heat rejection. | 132kW (7500 Btu/min) | 123kW (7000 Btu/min) |
| Design value for the water temperature at the exit from the keel cooler. | 60°C (140°F) | 60°C (140°F) |
| Design value for the water flow through the cooler. *Pipe work to suit 45mm (1.75") bore hose connections. | 77 l/min (17galls/min) | 66 l/min (14.5galls/min) |
| Intercooler Circuit (Includes gearbox oil cooler) Heat rejection | 25kW (1400 Btu/min) | 19kW (1100 Btu/min) |
| Design value for the water temperature at the exit from the cooler. | 38°C (100°F) | 38°C (100°F) |
| Design value for the water flow through the cooler. Pipe work to suit 32mm (1.25") bore hose connections. | 123 l/min (27galls/min) | 109 l/min (24 galls/min) |

Note: Under extreme conditions the water flow in the jacket circuit may increase to 40 gallons/min. Pipe work should have a clear bore of 38mm (1.5")

The pipe work between the engine and coolers should be as short and direct as is possible, but should be sufficiently flexible to allow the engine to move on it's flexible mountings. The layout should discourage the formation of air locks, and venting points should be provided wherever an air lock is likely to occur.

The keel cooling system should normally be filled with a water/antifreeze mixture containing 50% antifreeze. This mixture is necessary even in warm climates, as the anti freeze contains corrosion inhibitors which protect the engine cooling system.

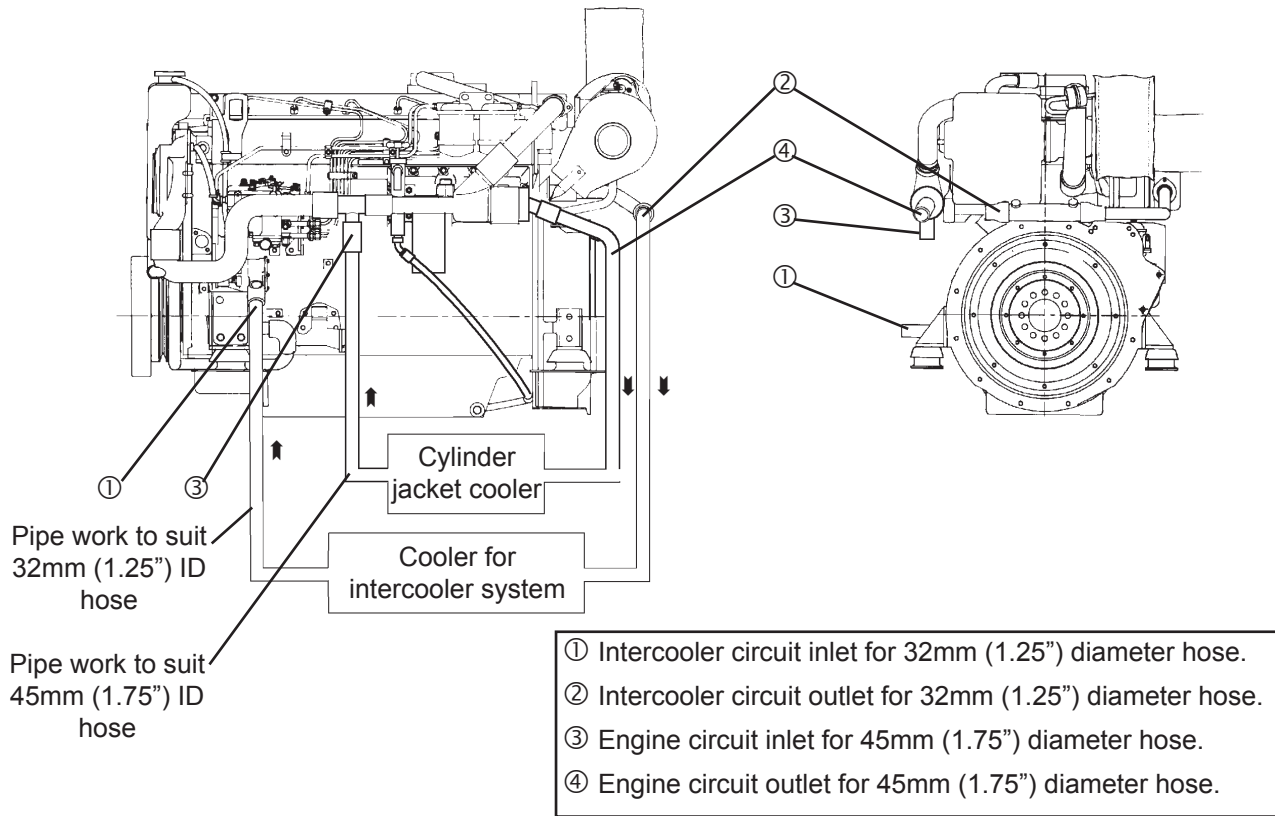

Figure 2 - Connections for keel coolers (M185C, M215C, M225Ti)

5.4 Keel Cooling System: M135 and M130C Engine

Both engine models may be purchased in a form suitable for keel cooling, using a cooler for the engine circuit. Figure 3 shows the connections provided for the cooler.

| | M135 | M130C |
|---|------------------------|------------------------|
| Engine Circuit Heat rejection | 123kW (7000Btu/min) | 123kW (7000Btu/min) |
| Design value for the water temperature at the exit from the keel cooler | 60°C (140°F) | 60°C (140°F) |
| Design value for the water flow through the cooler. Pipe work to suit 45mm (1.75") bore hose connections | 77 l/min (17galls/min) | 77 l/min (17galls/min) |

Note: Under extreme conditions the water flow in the system may increase to 180 l/min (40 gallons/min). Pipe work should have a clear bore of 38mm (1.5")

The pipe work between the engine and the cooler should be as short and direct as is possible but should be sufficiently flexible to allow the engine to move on it's flexible mountings. The layout should discourage the formation of air locks, and venting points should be provided wherever an air lock is likely to occur.

The keel cooling system should normally be filled with a water/antifreeze mixture containing 50% antifreeze. This mixture is necessary even in warm climates, as the anti freeze contains corrosion inhibitors which protect the engine cooling system.

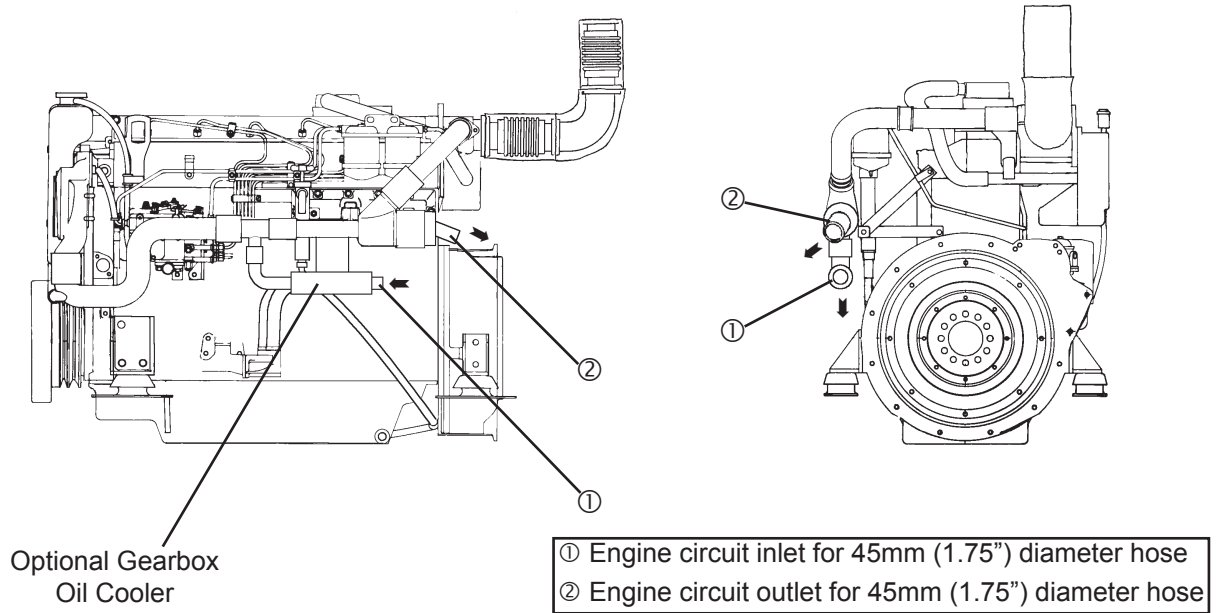

Figure 3 - Connections for keel coolers (M130C, M135)

5.5 Keel Cooling System: M115T M92 and M92B engine

Both engine models may be purchased in a form suitable for keel cooling. Figure 4 shows the connections provided for the keel cooler.

| | M115T | M92 / M92B |
|---|--|--|
| Engine circuit Heat rejection | 74kW (4200Btu/min) | 60kW (3400Btu/min) |
| Design value for the water temperature at the exit from the keel cooler. Design value for the water flow through the cooler. | 60°C (140°F) 45-70 l/min (10-15 galls/min) | 60°C (140°F) 45-70 l/min (10-15 galls/min) |
| Pipe work to suit 45mm (1.75") bore hose connections. | | |

The pipe work between the engine and the cooler should be as short and direct as possible but should be sufficiently flexible to allow the engine to move on it's flexible mountings. The layout should discourage the formation of air locks, and venting points should be provided wherever an air lock is likely to occur.

The keel cooling system should normally be filled with a water/antifreeze mixture containing 50% antifreeze. This mixture is necessary even in warm climates, as the antifreeze contains corrosion inhibitors which protect the engine cooling system.

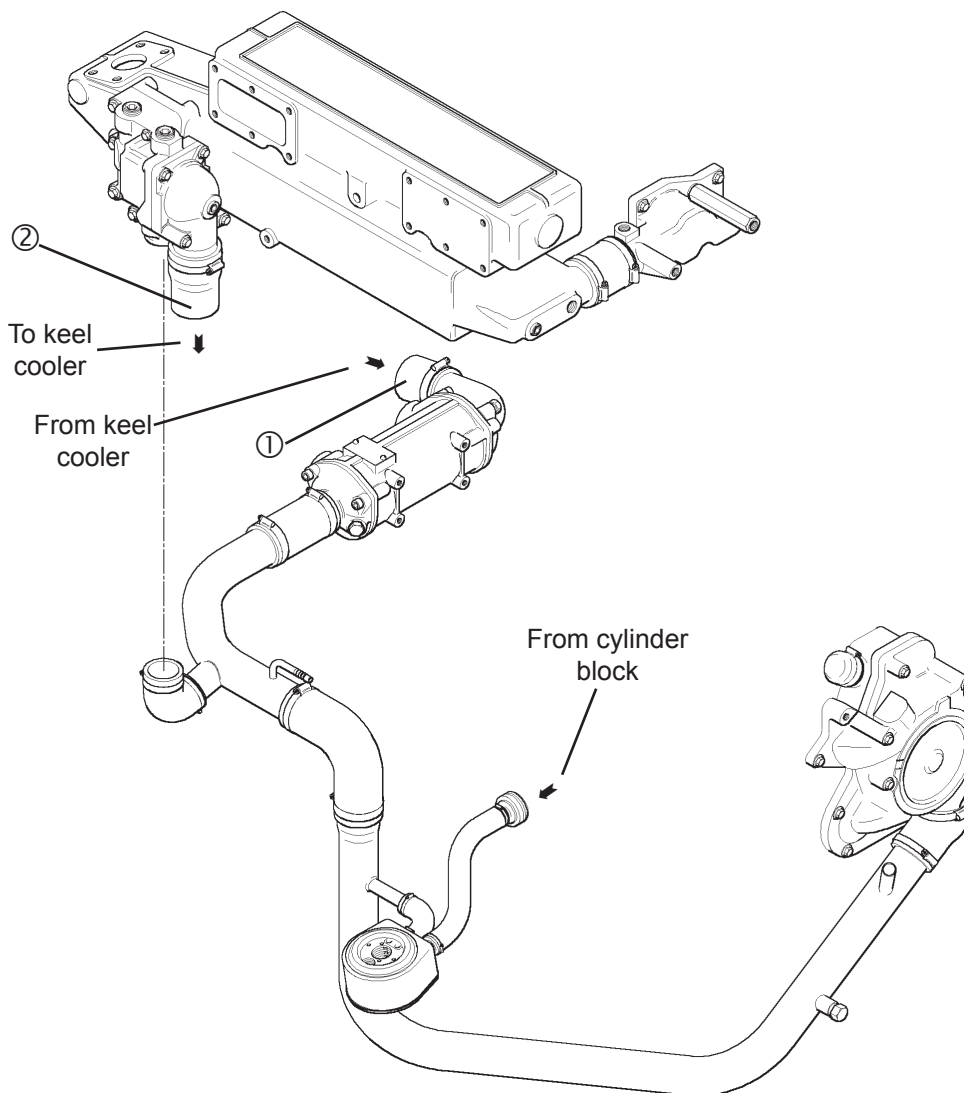
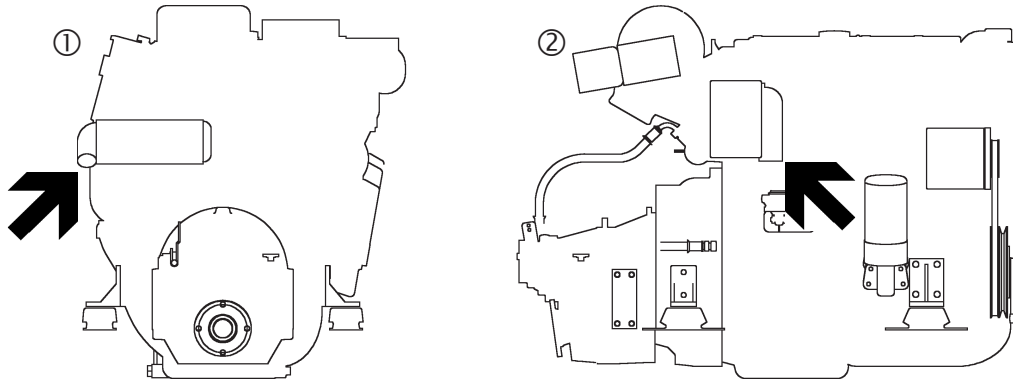

- ① Engine circuit inlet for 45mm (1.75") diameter hose
- ② Engine circuit outlet for 45mm (1.75") diameter hose

Figure 4 - Connections for keel coolers (M115T, M92)

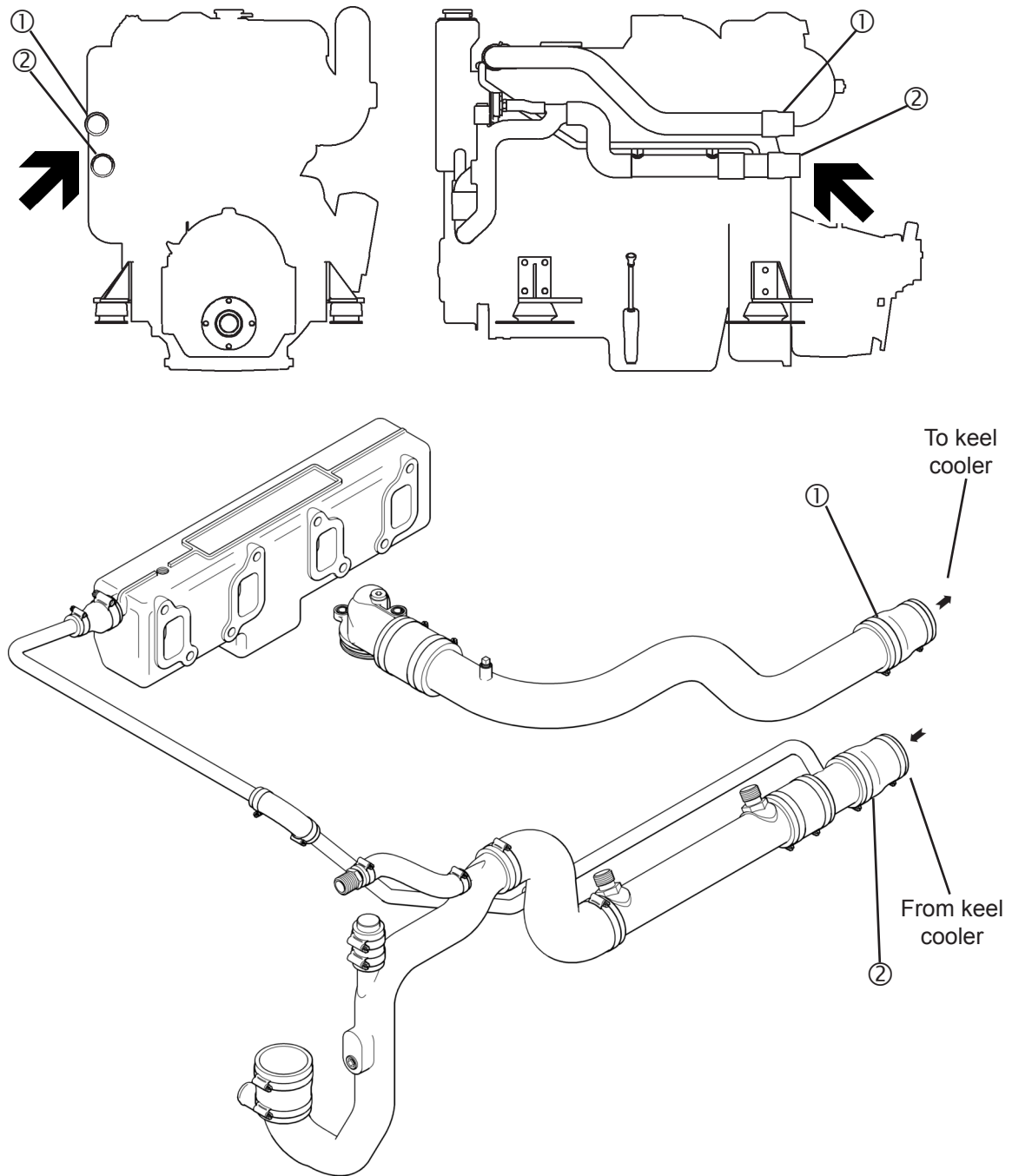

- ① Engine circuit inlet for 45mm (1.75") diameter hose
- ② Engine circuit outlet for 45mm (1.75") diameter hose

Figure 5 - Connections for keel coolers (M92B)

Fuel Systems

Design and assembly faults in the fuel system are responsible for many problems with marine diesel engines. A good system is not hard to achieve, being largely a matter of avoiding obvious pitfalls.

6.1 Fuel Connections

A common reason for service problems with fuel systems is the use of poor or incompatible connectors, where the pressure tightness depends upon the use of sealing compounds, hose clamps, fibre washers trapped between inadequate and unmachined faces, or compression fittings which have been over-tightened to the point where they no longer seal.

Cleanliness during initial assembly is also of vital importance, particularly when fuel tanks are installed, as glass fibres and other rubbish may enter tanks through uncovered apertures.

Thread details of the connections on the engines for fuel pipes

| | Model | |
|-------------|-----------------|--|
| | M300Ti / M265Ti | M225Ti / M215C / M185C / M135 / M130C / M115T / M92B / M92 |
| Fuel feed | 3/8" BSP | 1/2" UNS |
| Fuel return | 3/8" BSP | 7/16" UNS |

It is strongly recommended that the flexible fuel pipes available as an option with the engine are used, which are as follows:

Fuel Feed - M300Ti & M265Ti (Pt No 34051)

The free end of the flexible pipe has a 3/8" BSP cone ended fitting, and is supplied with an adaptor, nut, and olive to suit 10mm OD steel or copper tube.

- M225Ti / M215C / M185C / M135 / M130 / M115T / M92B & M92 (Pt No 34055)

The free end of the flexible pipe has a 1/2" UNS male thread, and is supplied with a nut and olive to suit 5/16" OD steel or copper tube.

Fuel Return - M300Ti & M265Ti (Pt No 34052)

The free end of the flexible pipe has a 3/8" BSP cone ended fitting, and is supplied with an adaptor, nut, and olive to suit 10mm OD steel or copper tube.

- M225Ti / M215C / M185C / M135 / M130 / M115T / M92B & M92 (Pt No 34054)

The free end of the flexible pipe has a 7/16" UNS male thread, and is supplied with a nut and olive to suit 1/4" OD steel or copper tube.

Fuel tanks should have the following features:

- The filler neck should be raised so that water will not enter when filling.
- The filler cap should seal effectively to prevent water entering when under way.
- A vent pipe should be fitted, again in such a way as to avoid the entry of water.
- The tank should have a sump or angled bottom with a drain tap so that water and sediment can be removed. (This is not always possible).
- Internal baffles may be required to prevent fuel surge.
- The tank should have a removable panel to simplify cleaning.
- The fuel pipe work should be as simple as possible with the minimum of valves and cross connections, so that obscure fuel feed problems are minimised.
- A fuel sedimenter (i.e. water trap) is required in the fuel system between the fuel tank and the engine mounted lift pump. To avoid problems when venting air after draining the sedimenter, it should preferably be installed below the normal minimum level of fuel in the fuel tank. (This is not always possible!).
- The tank should have at least two connections; a fuel feed connection, and a fuel return connection. Whenever possible a tank should only supply one engine, but in any case each engine should have its own fuel pipes, from tank to engine.

6.2 Typical Fuel Systems

The more simple the fuel system, the better it will perform in service. Figure 1 shows an ideal system.

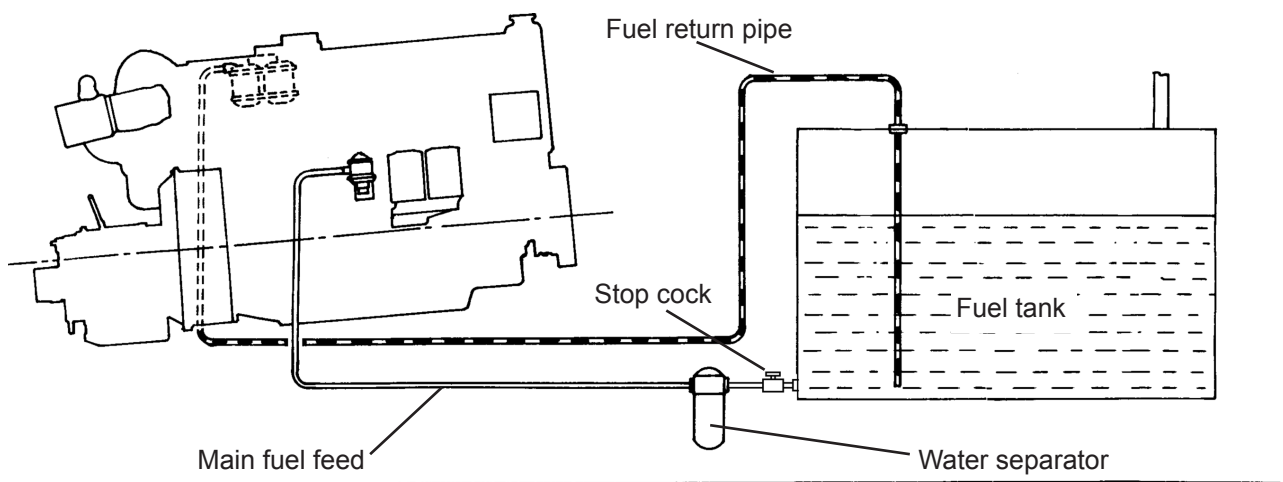

Figure 1 - A Simple Fuel System.

In some applications there may be legislation that requires that fuel lines draw from, and return to, the top of the tank. Figure 2 shows an acceptable arrangement.

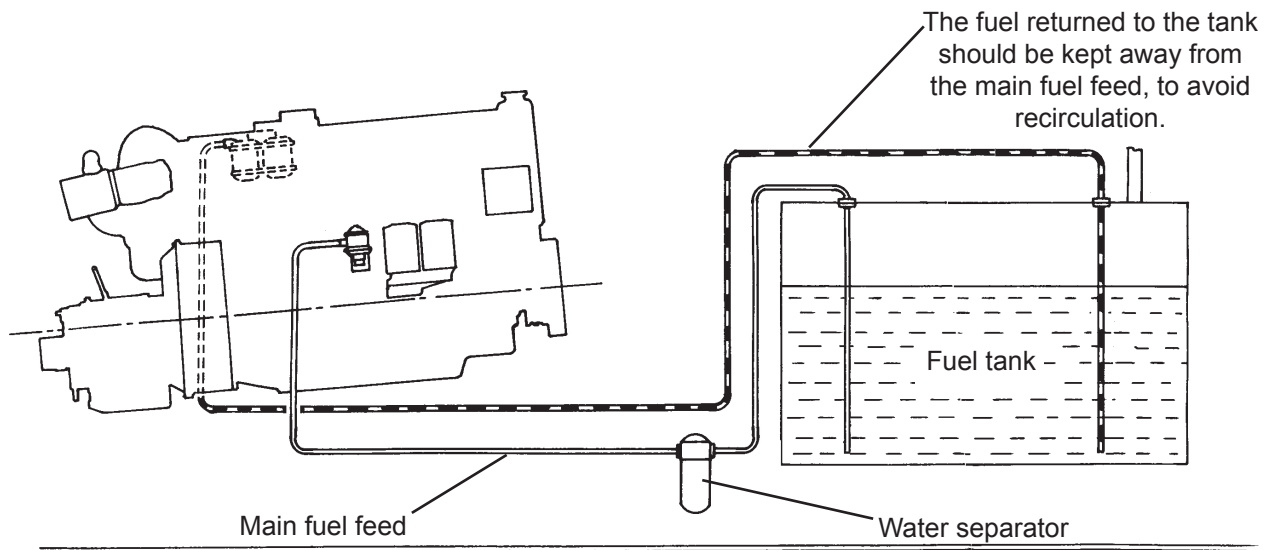

Figure 2 - A simple fuel system with connections through the top of the tank

The fuel tank may be steel, aluminium, or G.R.P. or, alternatively, a rubber bag tank may be used. The main fuel connection is taken from the rear of the tank so that all the fuel is available for use when under way when the hull will be at an angle. The fuel return is extended within the tank to near the bottom in order to prevent air locks which can arise due to syphoning of the fuel when the engines are stopped.

From the tank the main engine feed line goes first to a water separator, preferably one fitted with a thick clear plastic bottom and a drain cock. The fuel lines may be of metal, either copper or 'bundy' steel tubing used either with compression fittings or preferably soldered nipples, with a flexible armoured rubber hose to connect to the fuel lift pump.

This simple fuel system is satisfactory when one or more engines are run from a single fuel tank, and it may also be used when there are two tanks each supplying one engine. In the latter case the system may include a cross connection, between the tanks by means of a balancing pipe, with a valve, at each end. In some installations cross connecting pipes between the two engine feed pipes and the two engine return pipes have been used, but valves are necessary in every line so that the appropriate system may be selected, and the complexity of installation and operation is such that the advantages in operating flexibility are out-weighted by the possibility of obscure problems due to component malfunctions, incorrect operation or engine interaction.

In some cases it is necessary to have a number of fuel tanks in order to achieve the required operating range. In such cases, where possible, one tank should be regarded as the main tank for each engine and the other tanks should be arranged so that they will drain into the main tank by gravity. If a gravity system is not possible, then the system shown in Figure 3 should be used.

Figure 3 shows a collector tank, fed by all the storage tanks and connected to the engine feed and return systems, but with a vent pipe taken to any convenient tank.

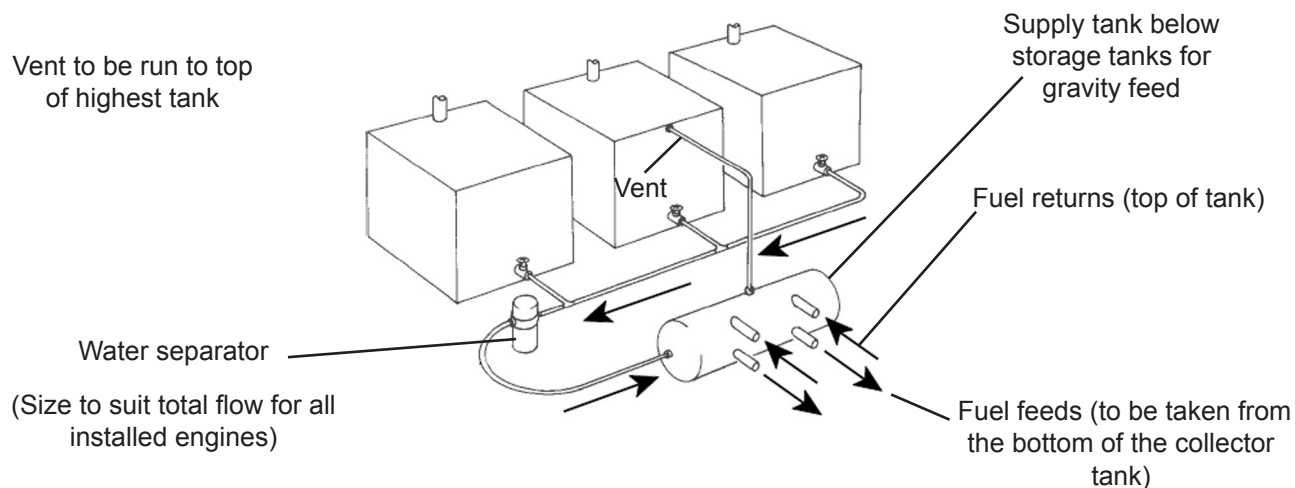

Figure 3 - Fuel System for multiple tanks - supplying multiple engines

There is no doubt however, that a simple fuel system as illustrated in Figure 1 should be used wherever possible, as having a completely separate tank and supply to each engine guarantees that if an engine stops, due to running out of fuel or to water or foreign matter in the fuel, the other engine will not be affected simultaneously. This will give some time for appropriate manoeuvring action to be taken. The simple system will also require the minimum number of valves and fittings, which ensures maximum reliability in service.

Engine Electrical Systems

A plug-together electrical system is available with the engine, providing the following choices:-

- Earth return or insulated return (except M115T, which is earth return only).
- Interconnecting cables of 4, 6, 8, 10 or 12m length.
- A 'Y' harness to allow multiple instrument panels to be fitted.
- 12V or 24V operation.
- Instrument panels - basic or comprehensive, which may be used individually or in combination.

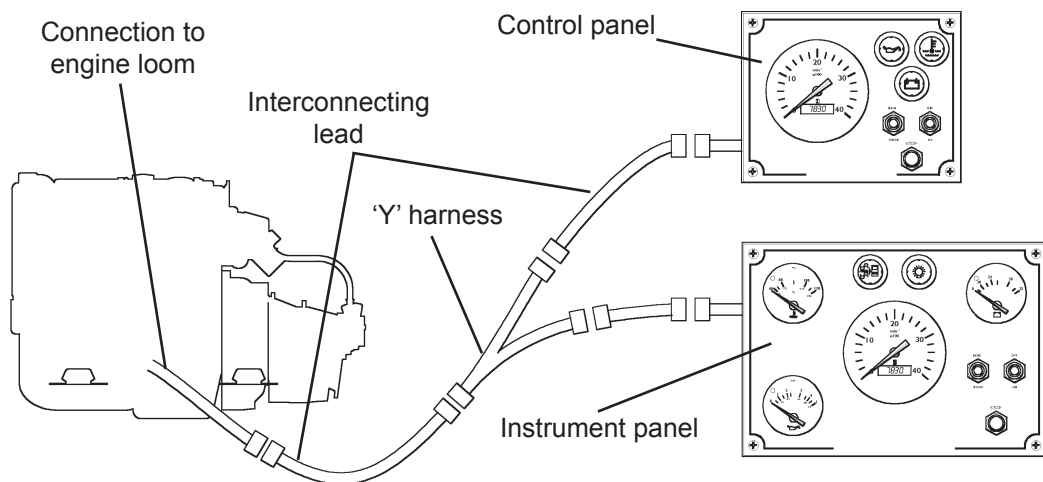

Figure 1 - Elements of the plug together system.

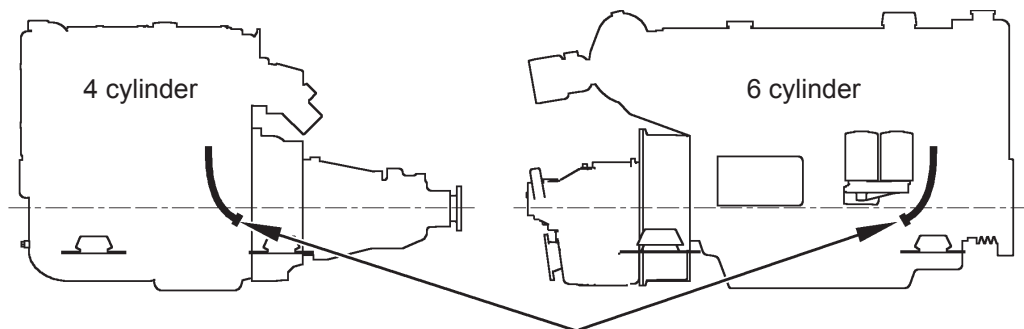

Figure 2 - Position of the multi-way connector for the engine wiring loom.

7.1 Engine Wiring Looms

The engine wiring loom connects the starter, alternator, fuse board, electric stop, engine senders and warning switches to a waterproof (IP67) multiway connector situated on a flying lead attached to the engine at the positions shown on Figure 2.

The circuit diagrams for the various models are listed below:-

- Figure 3 All 4 cylinder models - earth return.
- Figure 4 M92 - insulated return.
- Figure 5 M92B - 12 and 24 volt insulated earth.
- Figure 6 All 6 cylinder - insulated and earth return.
- Figure 7 6 cylinder - insulated and earth return, fitted with Motorpal PP6M 10Pi fuel injection pump.

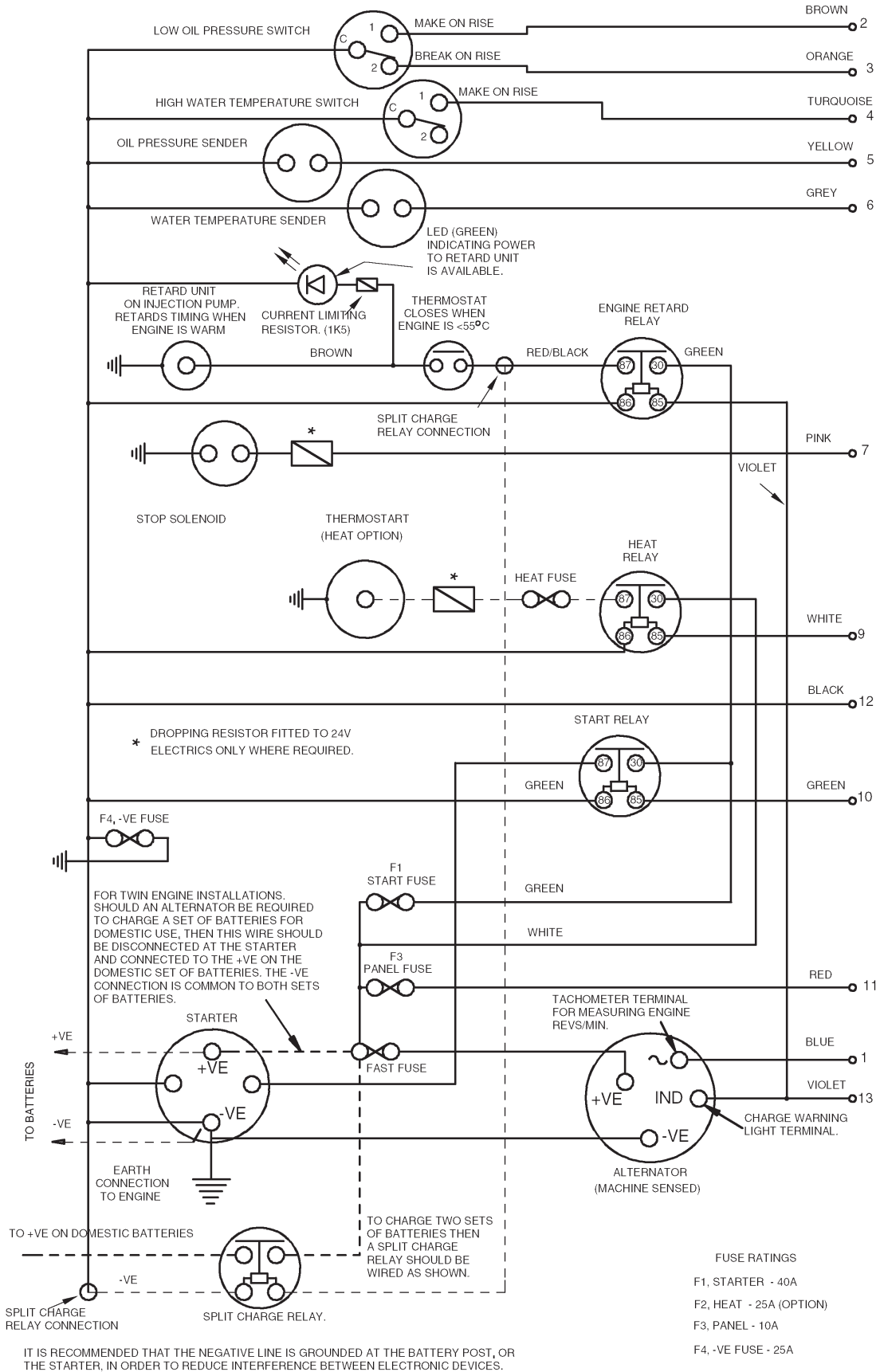

Figure 3 - All 4 cylinder models - earth return - circuit diagram
 Information derived from drawing number 99-1069-3

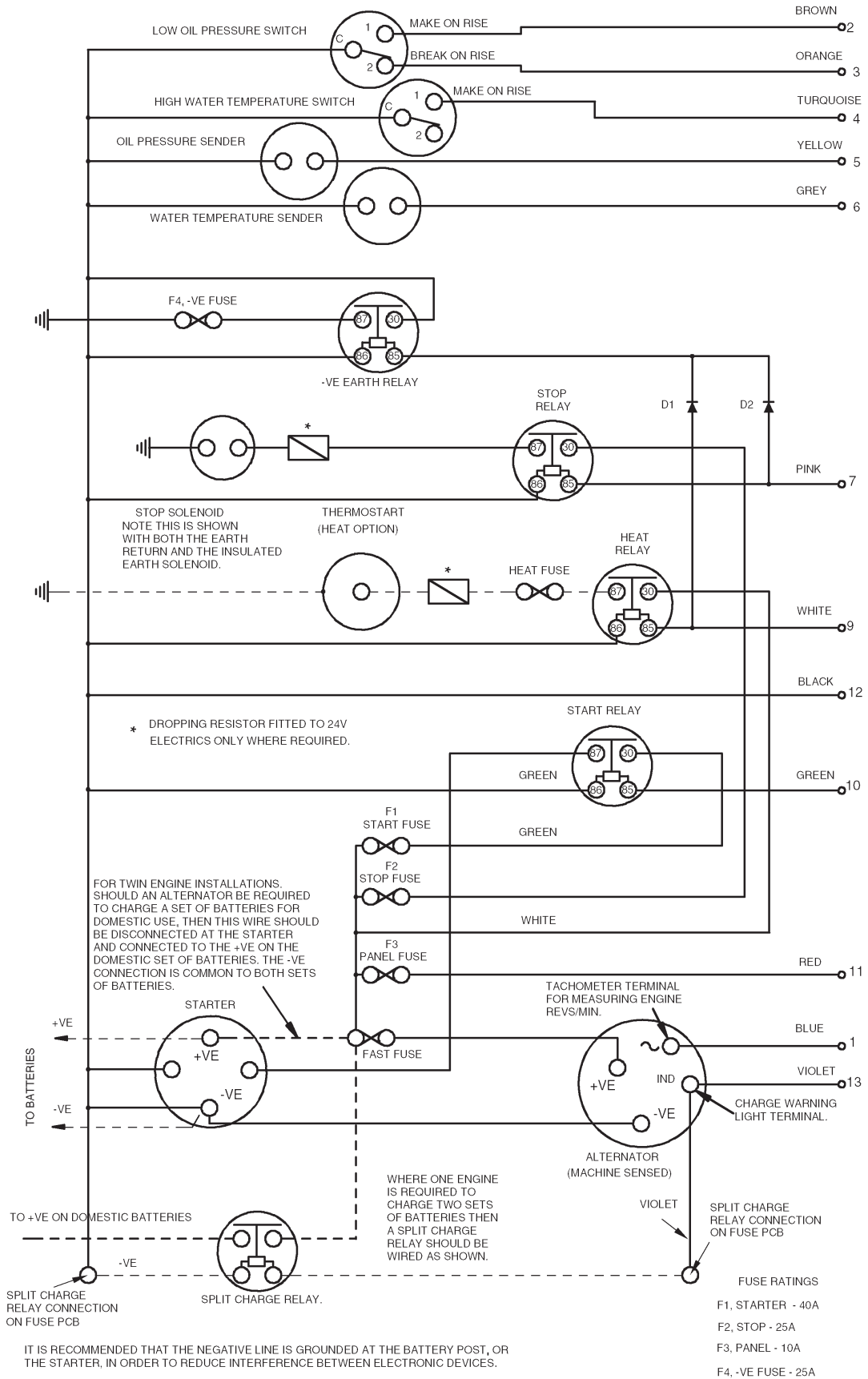

Figure 4 - M92 - insulated return - circuit diagram
 Information derived from drawing number 99-1151-3

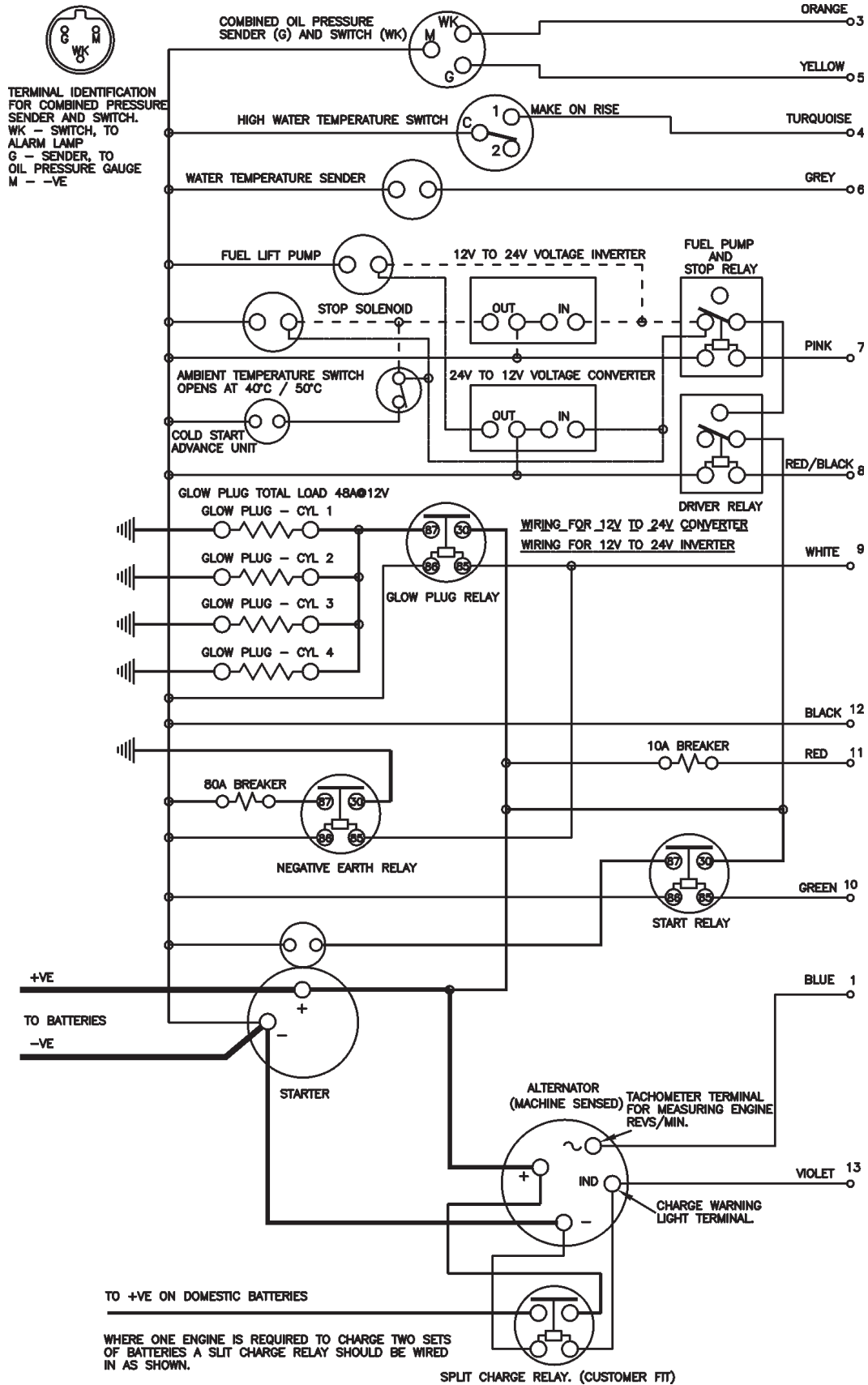

Figure 5 - M92B - 12 and 24 volt insulated earth - circuit diagram
 Information derived from drawing number 04-1270-3

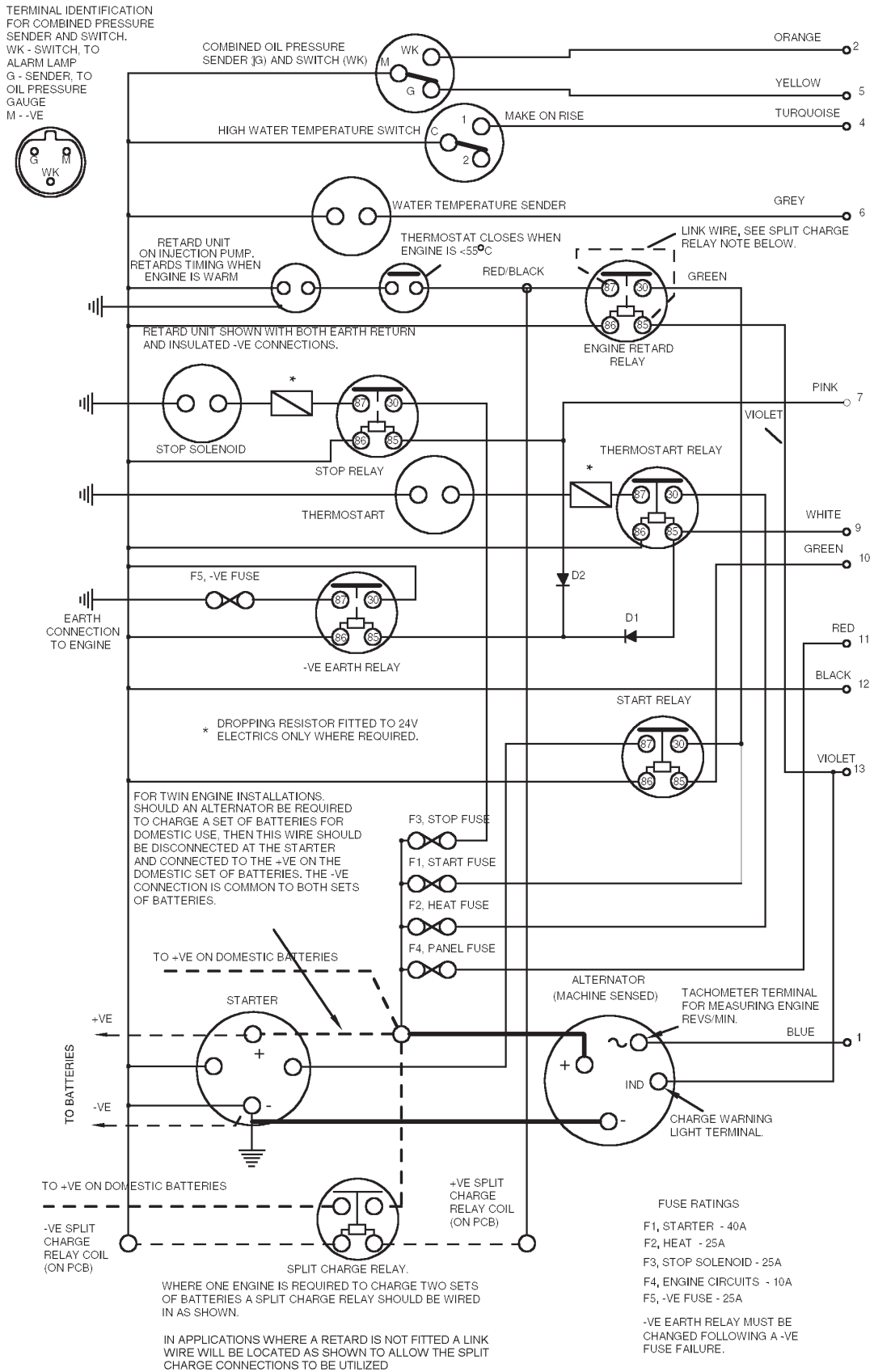
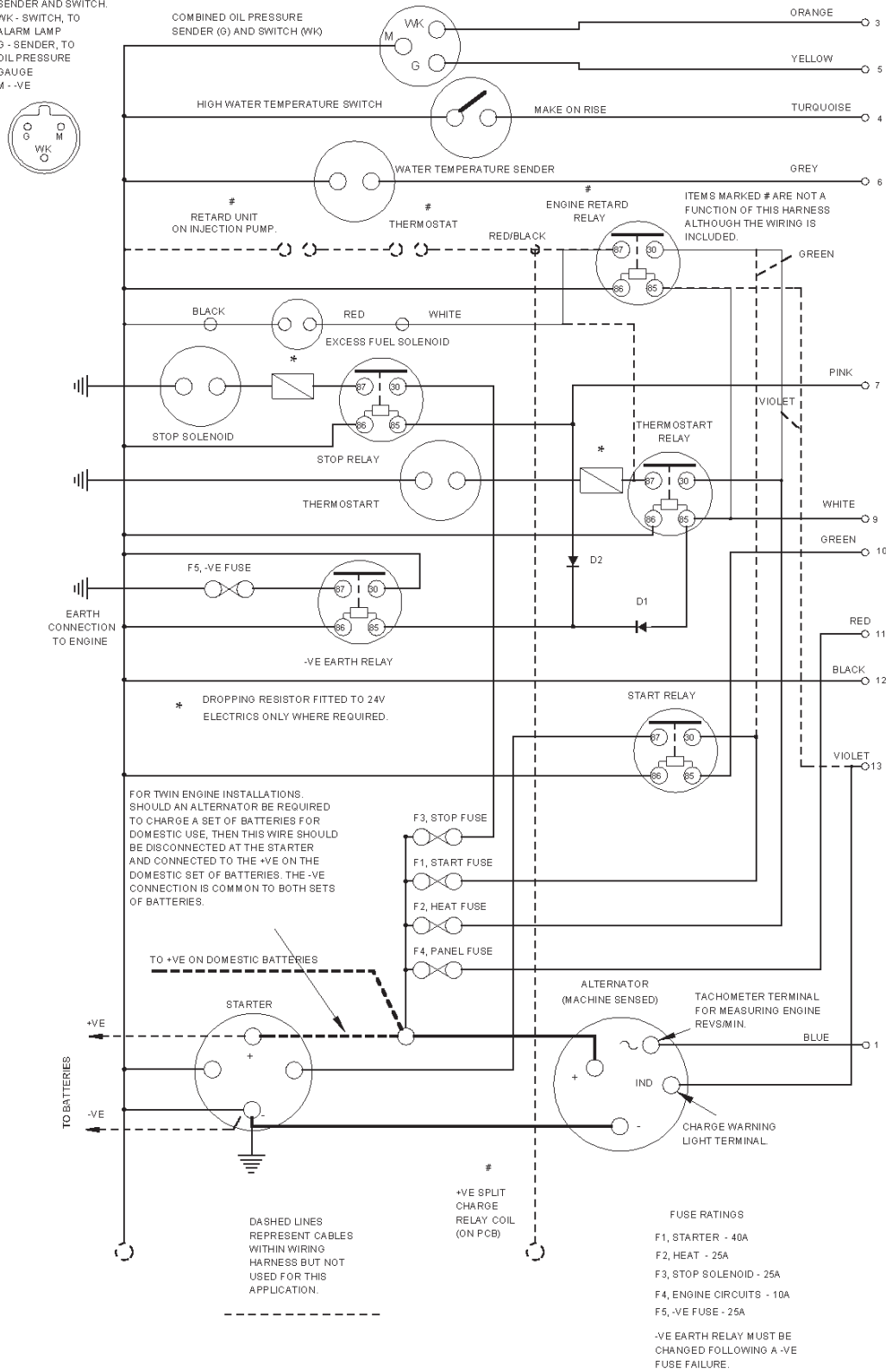

Figure 6 - All 6 cylinder models - insulated and earth return - circuit diagram
 Information derived from drawing number 00-1020-3

TERMINAL IDENTIFICATION FOR COMBINED PRESSURE SENDER AND SWITCH.
 WK - SWITCH, TO ALARM LAMP
 G - SENDER, TO OIL PRESSURE GAUGE
 M - -VE



IT IS RECOMMENDED THAT THE NEGATIVE LINE IS GROUNDED AT THE BATTERY POST, OR THE STARTER, IN ORDER TO REDUCE INTERFERENCE BETWEEN ELECTRONIC DEVICES.

Figure 7 - 6 cylinder models - insulated and earth return - circuit diagram fitted with Motorpal PP6M 10Pi fuel injection pump. Information derived from drawing number 01-1064-3

7.2 Fuse board

Note: Fuses are provided to protect the electrical system against accidental short circuits. The risk is highest when the engine is being installed, or when additional equipment is wired in, and is negligible during normal operation.

On all models the fuse board may be found behind a plastic cover, adjacent to the starter motor.

For identification of fuses. (See Figure 8).

| Fuse | 4 cylinder models | 6 cylinder models |
|------|--|-------------------|
| 1 | Start 40A | Start 40A |
| 2 | Not fitted | Heat 25A |
| 3 | Panel 10A | Stop 25A |
| 4 | Negative 25A | Panel 10A |
| 5 | Fast fuse - 80A nom. Check value of fuse. | - |

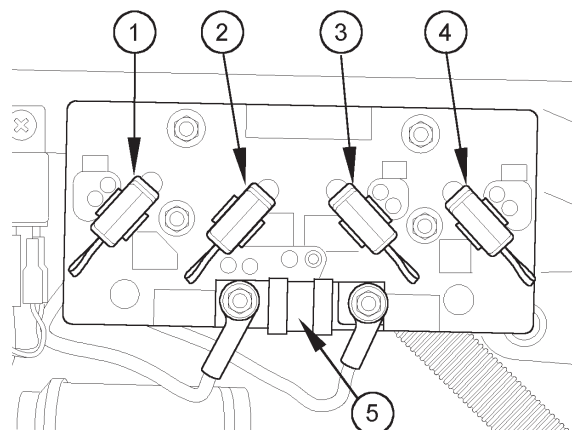

Figure 8 - Fuses

Negative fuse - 6 cylinder models only

An additional fuse is located at the front of the engine, behind the plastic belt cover (see Figure 9). This fuse is to protect the engine wiring from damage due to the cylinder block being inadvertently connected to the battery positive, and then grounded through the earth relay.

Note: When replacing the -ve fuse, the earth relay must also be replaced.

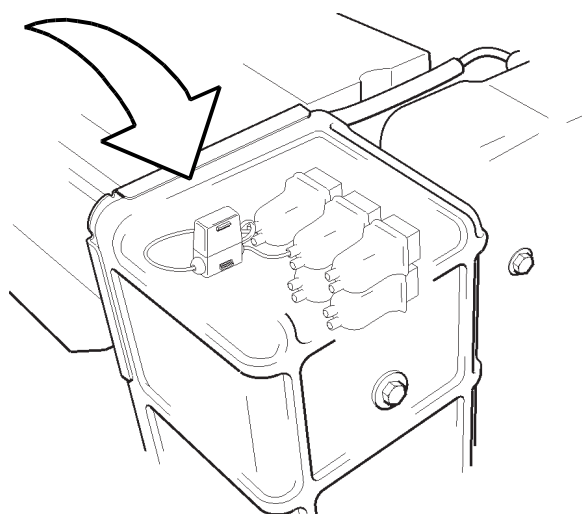

Figure 9 - Negative fuse

e of the engine behind the alternator.

The 10A circuit breaker is to protect the instrument and control panel/panels mounted away from the engine.

The 80A circuit breaker is to protect the negative line during momentarily grounding the engine whilst of the glow plugs are operating. This protects the engine harness in the event of a stray positive supply accidentally finding its way to the block. This is most likely to happen during installation.

Voltage Sensitive Equipment

The M92B contains two components that are voltage sensitive and therefore require an additional piece of equipment when the voltage is outside of their operating range. They are:

The stop solenoid fitted to all engines is for 24v operation.

The fuel lift pump fitted to all engines is for 12v operation.

M92B – 12v models are supplied with a voltage inverter that inputs 12v and outputs 24v. This allows the stop solenoid to function when required. The inverter is coloured red.

M92B – 24v models are supplied with a voltage converter that inputs 24v and outputs 12v. This allows for the continuous operation of the fuel lift pump when the engine is running. The converter is coloured black.

Both the inverter and converter are supplied with an extension lead so that they can be mounted away from the engine.

Inverter/Converter Fitting Instructions

Note: The inverter/converter must not be engine mounted.

1. Select a cool, dry and ventilated position.
2. Use the bracket to mark the position of the holes.
3. Drill 3.5mm holes.
4. Fix the clip using screws provided.
5. Click the unit onto the clip.
6. First connect both input wires. Second connect the output wires.
7. Max. temp. 55°C. Mount unit remote from engine in a cool, dry and ventilated position.

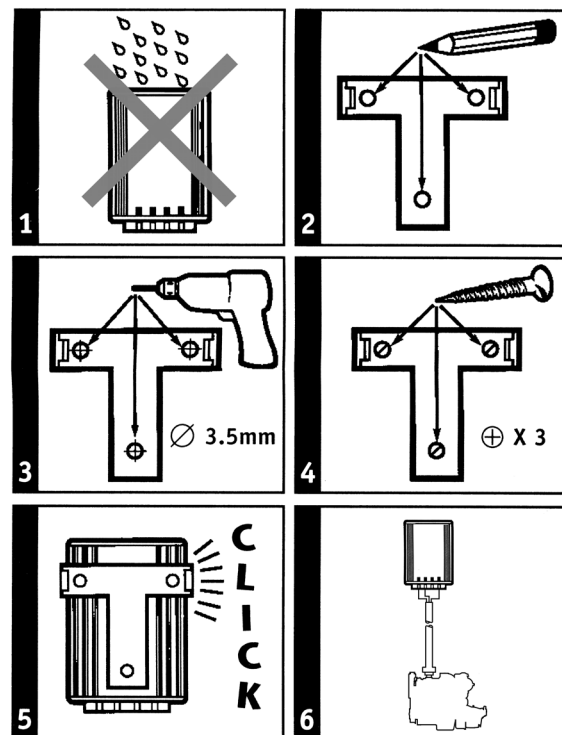

7.4 Interconnecting Cable

Interconnecting cables (Figure 10) are used to join the engine loom to the instrument panel(s). Cables are made in 4, 6, 8, 10 and 12m lengths and all cables have a male plug (1) at one end and a female (2) at the other. Cables may be plugged together to give up to 12m length, but in general if a longer cable is required it should be ordered as a special item, to be made in one piece.

A 'Y' harness (Figure 11) is available, with a male plug at (1) and two female plugs (2). If necessary, more than one 'Y' harness may be used, to connect several instrument panels together, in any of the combinations shown on Figure 15.

Details of the plugs and sockets, and the wiring of the 'Y' harness are shown on Figure 11.

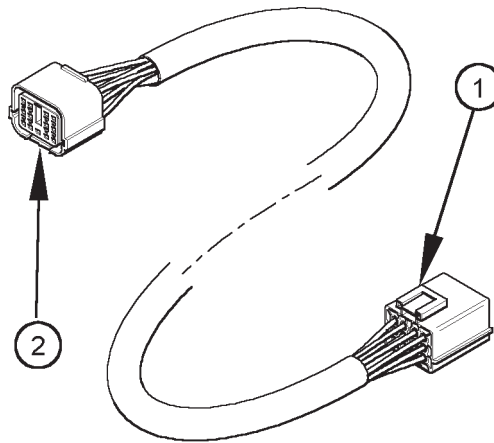

Figure 10 - Interconnecting cable

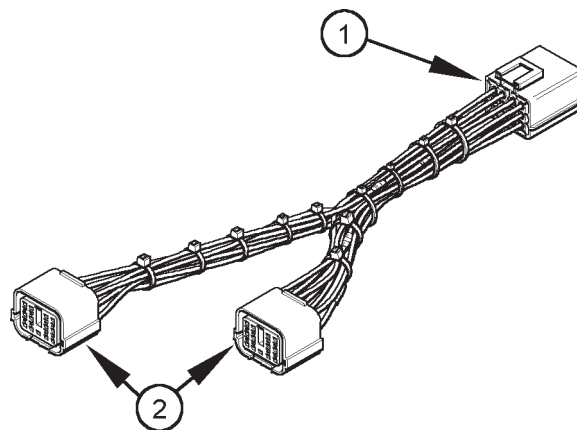
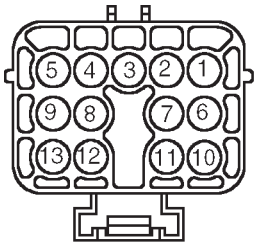
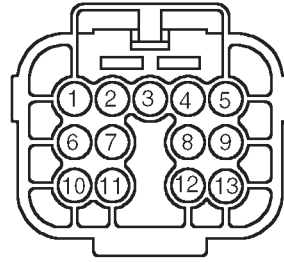

Figure 11 - 'Y' harness



MALE
MULTIWAY
CONNECTOR

VIEWED ON THE
CABLE ENTRY.



FEMALE
MULTIWAY
CONNECTOR

VIEWED ON THE
CABLE ENTRY.

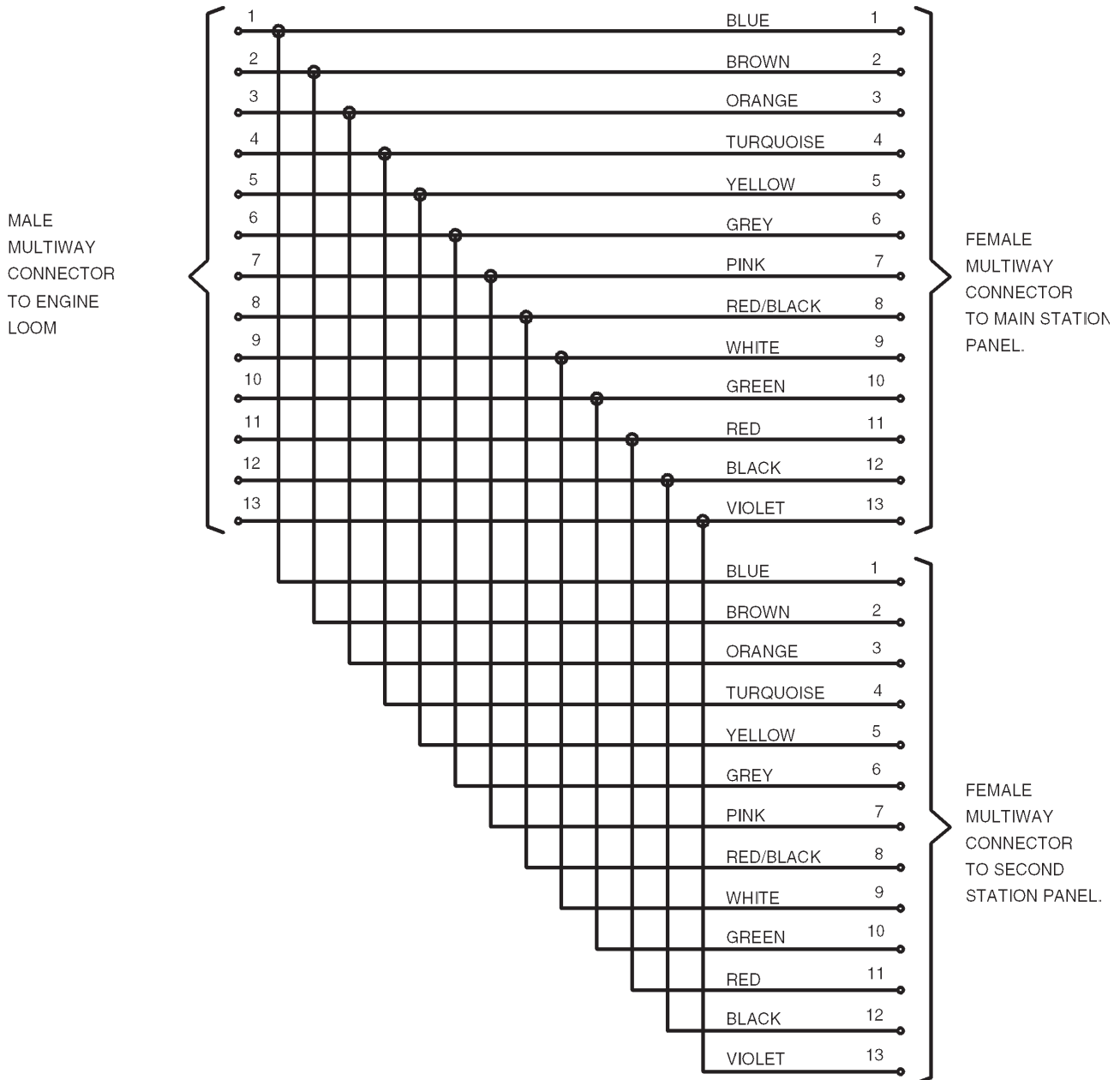

Figure 12 - Schematic of 'Y' harness part number 34621
Information derived from drawing number 98-1044-1

7.5 Instrument Panels

Two types of panel are available, providing different levels of instrumentation. The 'Instrument Panel' shown in Figure 13 includes:-

1. Panel illumination level switch
2. Water in fuel warning lamp
3. Charge warning lamp
4. Voltmeter
5. Heat/start switch
6. On/off switch
7. Stop switch
8. Oil pressure gauge
9. Low oil pressure warning lamp
10. Tachourmeter
11. Water temperature gauge
12. High water temperature warning lamp

The circuit diagram of this panel is shown in Figure 14.

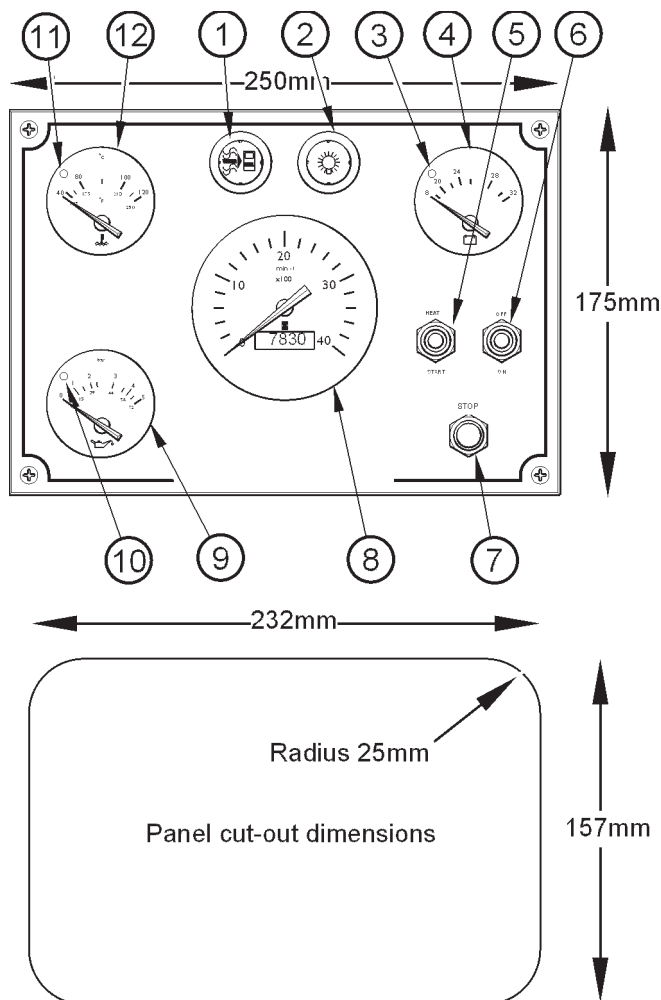

Figure 13 - Instrument panel

Panel Set-up Information.

Master - Slave Configuration.

All panels are supplied configured as master panels.

In the event that more than one panel is being used to control one engine then there is the choice of making one of them a slave to the other (master) panel. Where there is one panel in the wheelhouse and another on the flybridge then there is the option of making the control functions on the flybridge panel (slave) only operational when the wheelhouse panel (master) is switched on.

The illustration below shows the removable link on the rear of the panel. To convert a panel to slave remove the link from the master (M) terminal and refit to the slave (S) terminal.

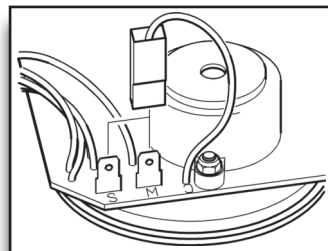

Note that one panel must always be a master and that no more than two panels should be connected to one engine without reference to Wimborne Marine Power Centre.

Tachometer Set-up Procedure

All panels are supplied set to match their associated engine.

In the event that the tachometer needs re calibrating refer to diagram and instructions below:

Designations in the wiring diagram:

30 - terminal 30 - steady-state plus 12 V

15 - terminal 15 - connected (ignition) plus

58 - terminal 58 - lighting

31 - terminal 31 - ground

F1 - fuse 5A quick-response

S1 - light switch

C1 - 8-pin MQS connector

C2 - 14-pin MQS connector

Config - Configuration key

Mode - Mode key

W1 - Alarm output (max. 100 mA)

You must comply with the wiring diagram

8-pin connection 14-pin connection

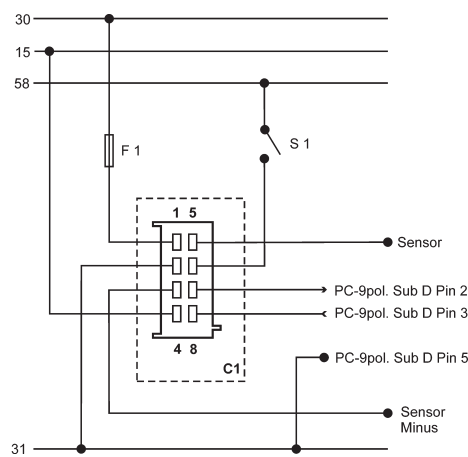

14-pin connection

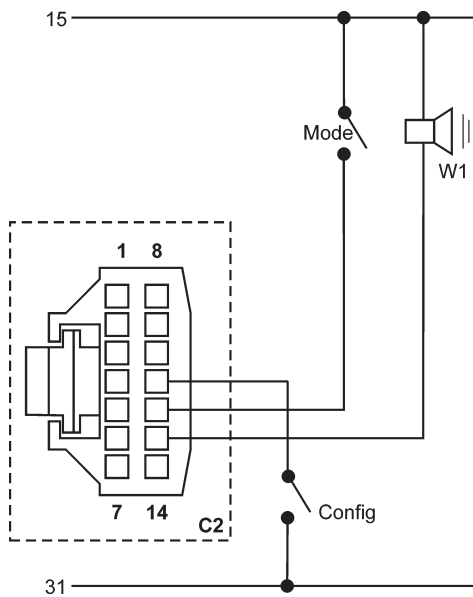

Basics:

- Press the key briefly (< 2sec.) to change the currently displayed value.
- Press the key longer (< 2sec.) to change to the next value.
- The display returns to normal operating mode if a key is not pressed for 30 seconds. Any settings you have made are not saved.

Start-up

- Setting the impulse number
- Activate T. 30 (8-pin - Pin1)
- Deactivate T. 15 (8-pin - Pin4)
- Press and hold Config key (14-pin - Pin 11)
- Activate T. 15
- Release Config Key
- Press and hold Config Key. Set impulse number is displayed, the first digit flashes.
- Press Config key briefly. The flashing digit increases by 1. If the flashing digit is "9", the display returns to "0".
- Press Config key briefly. The next lower digit flashes.
- Press Config key briefly. The flashing digit increase by 1. If the flashing digit is "9", the display returns to "0". Continue until the complete impulse number is set.
- Press and hold Config key.
- Deactivate T. 15. This saves the impulse number in the display.

Note: to establish the correct setting for the tachometer the following formula should be applied.

Diameter of Alternator

Driven Pulley

----- X 6 = Number of Pulses

Diameter of Alternator

Driven Pulley

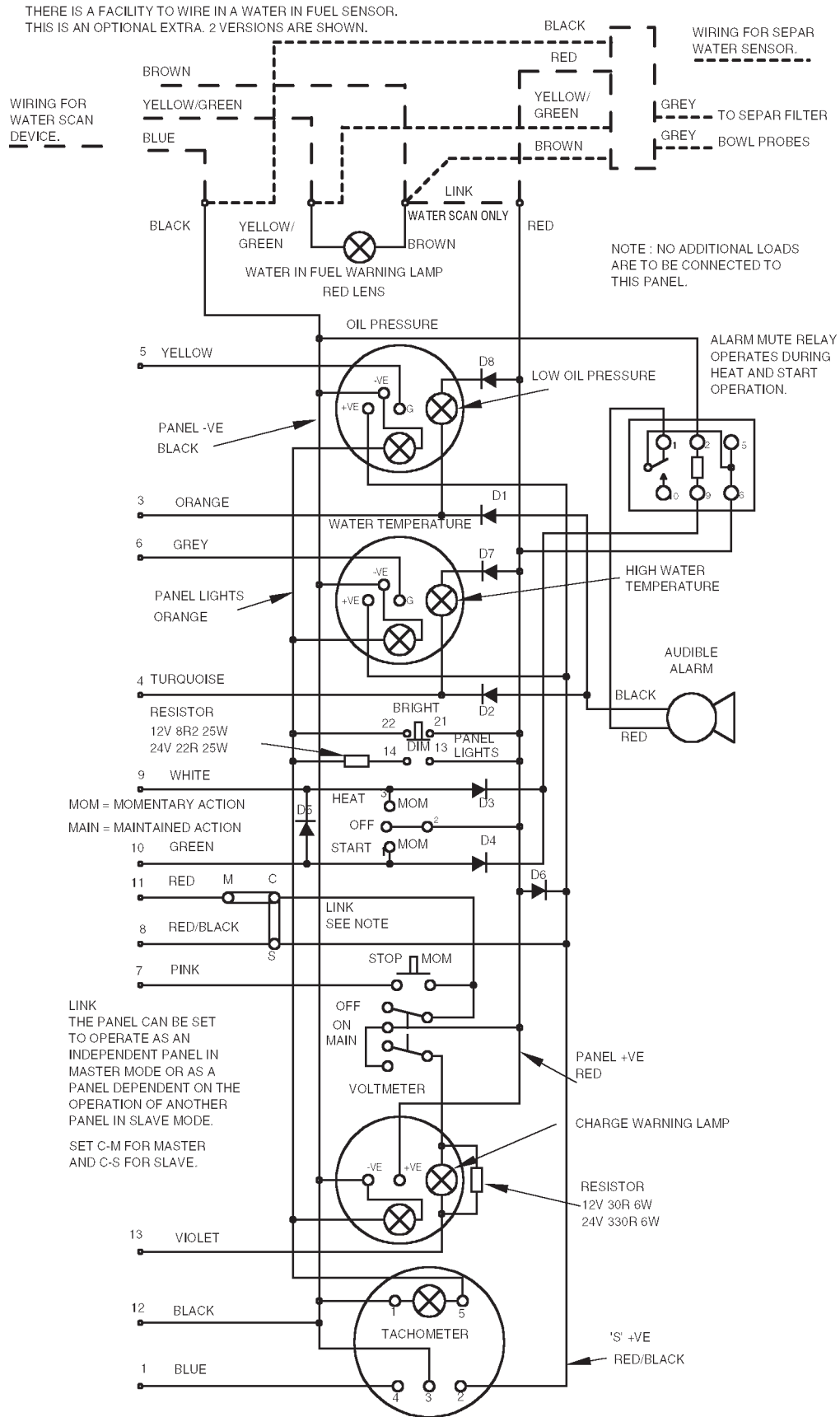

INSTRUMENT PANEL WIRING DIAGRAM 98-1043-3

Figure 14

The 'Control Panel' shown in Figure 15 includes:-

1. Low oil pressure warning lamp
2. High coolant temperature lamp
3. Charge warning lamp
4. On/off switch
5. Heat/start switch
6. Stop switch
7. Tachourmeter

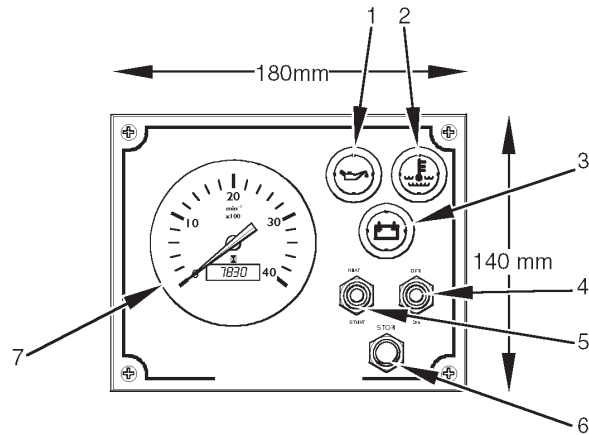

The circuit diagram for the 'Control' panel is shown in Figure 17.

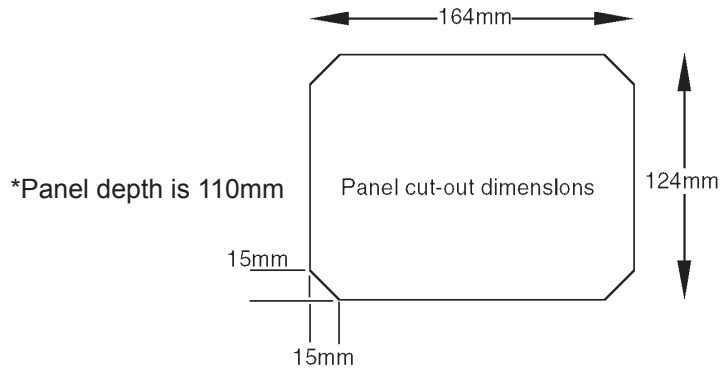

Figure 15 - Control panel.

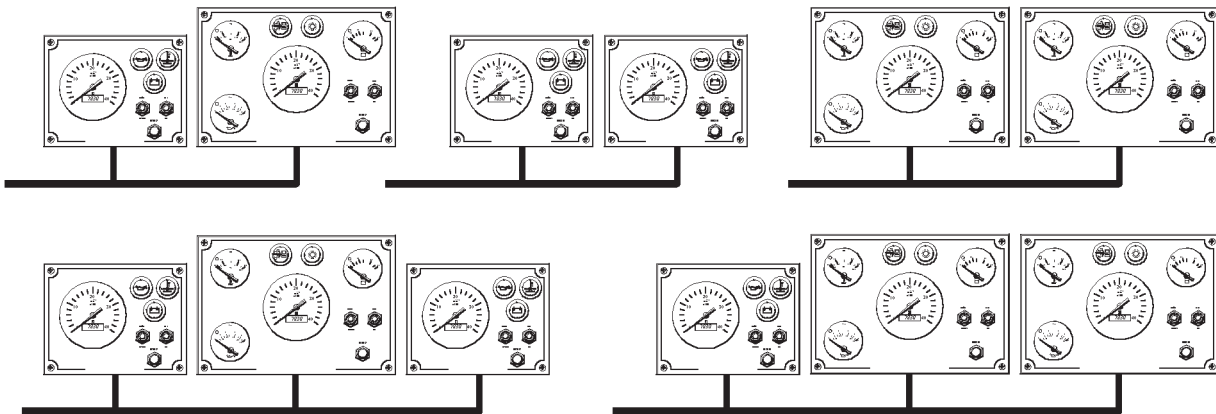
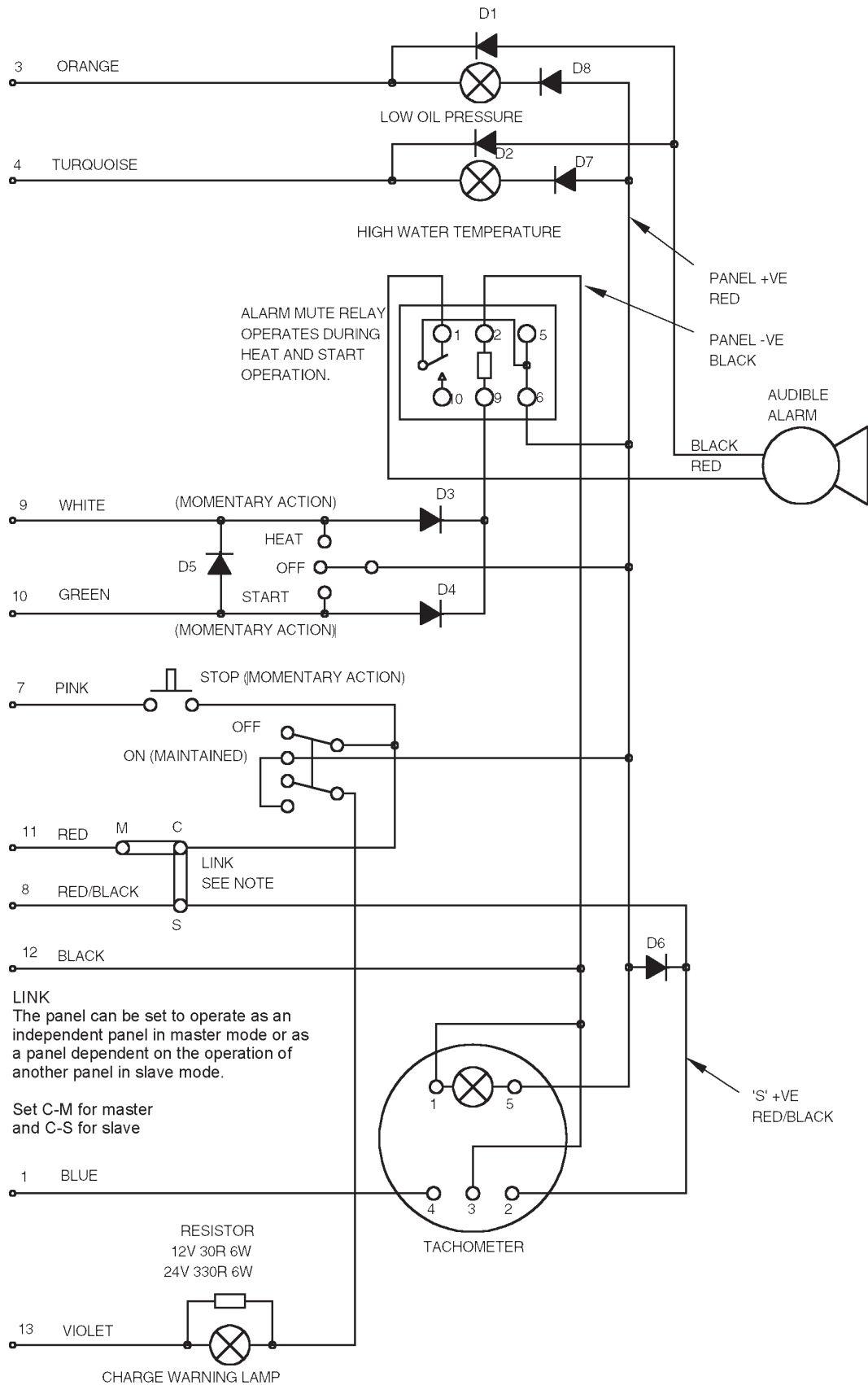

Figure 16 - Possible panel configurations.

Up to three panels may be run simultaneously, in any of the combinations as shown.



CONTROL PANEL WIRING DIAGRAM 98-1055-3

Figure 17 - Control panel - circuit diagram

7.6 Battery and Starter Cables

(a) Batteries

There are two methods by which battery performance is commonly stated:-

- BS3911 uses the current which can be maintained for 60 seconds, without the voltage of a nominal 12V battery dropping below 8.4 volts, whilst at a temperature of -18°C.
- SAE J537 is similar except that the current is only maintained for 30 seconds and the voltage is allowed to fall to 7.2 volts.

| Model | Batteries for temperatures down to -5°C (23°F) | |
|--|--|--|
| | 12 Volt | 24 Volt |
| M300Ti M265Ti M225Ti M215C M185C | One battery - 520 Amps BS3911 or 800 Amps SAE J537 | Two 12V batteries in series - each 315 Amps BS3911 or 535 Amps SAE J537 |
| M135 M130C | Two 12V batteries in parallel - each 315 Amps BS3911 or 535 Amps SAE J537 | |
| M115T M92B | One battery - 520 Amps BS3911 or 800 Amps SAE J537 | Two 12V batteries in series - each 440 Amps BS3911 |
| Batteries for temperatures down to -15°C (5°F) | | |
| M300Ti M265Ti M115T M92 | Two 12V batteries in parallel, each 520 Amps BS3911 or 800 Amps SAE J537 | Two 12V batteries in series, each 520 Amps BS3911 or 800 Amps SAE J537 |
| M225Ti M215C M185C M135 M130C | Two 12V batteries in parallel - each 315 Amps BS3911 or 535 Amps SAE J537 | Two 12V batteries in series - each 315 Amps or 535 Amps SAE J537 |

Note: Where starting at temperatures below freezing is an important requirement, a 24 volt system is the preferred choice.

(b) Starter Cables

| Starter cables for 12 or 24 volt systems | | | | | | | | |
|--|-------|-------------------|-----------------|-----------------|----------------------------|-----------|-------------------------|-----------------|
| *Maximum total length | | Cable size metric | Nominal C.S.A. | | Nominal resistance in ohms | | Approx. equivalent size | |
| Metres | Feet | | mm ² | in ² | Per metre | Per foot | English imperial | America B&S SAE |
| 5,6 | 19.00 | 61/1,13 | 61 | 0.0948 | 0,000293 | 0.0000890 | 61/.044 | 00 |
| 9,0 | 28.30 | 19/2,52 | 95 | 0.1470 | 0,000189 | 0.0000600 | 513/.018 | 000 |

* The length of all cables in the starter circuit (whether positive or negative), should be added together to give the 'Total Length'

(c) Grounding the battery negative

It is recommended that the battery negative busbar should be grounded as close as possible to the battery, by a substantial connection to the bonding system within the boat. This will reduce the likelihood of interference between items of electrical and electronic equipment fitted to the boat.

(d) Battery isolator switches

A switch should be fitted in the positive lead to the starter, as close to the battery as is convenient. The switch should be suitable for a momentary current of at least 1000 Amps.

7.7 Zinc Anode bonding system

Caution: *The engine may be damaged by electrolytic corrosion if the correct bonding procedure is not adopted. Please read the guidelines below carefully.*

(a) Electrolytic corrosion within the engine cooling system and transmission can be much reduced or eliminated by bonding the engine to a Zinc anode which is used to protect through the hull metal fittings and other metal components that are in contact with sea water. The engine is fitted with a stud that may be used for this purpose, see, 'Location of engine installation points' at the beginning of this manual, for location of the stud. The stud is identified by a label, shown below:

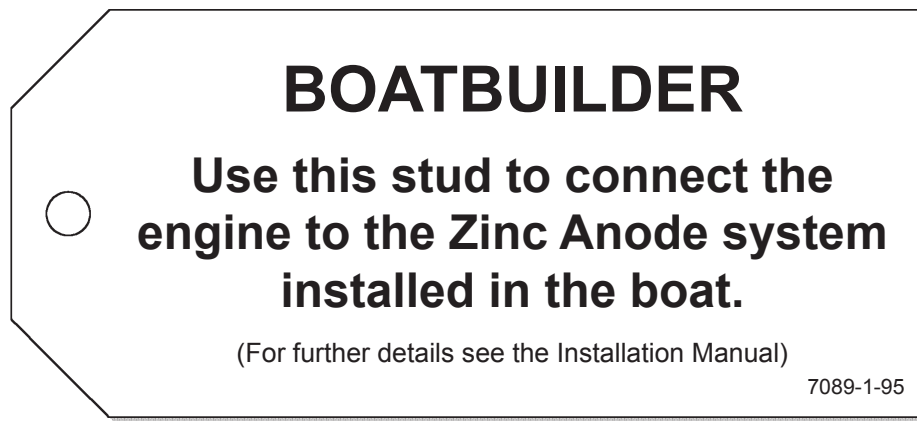

(b) Typical system in common use

The bonding system in the boat should provide a low resistance connection between all metals in contact with sea water, together with a connection to a Zinc sacrificial anode which is fixed to the outside of the hull below sea level.

The bonding should consist of heavy stranded wire (not braiding or wire with fine strands). It is an advantage if the wire is tinned. Insulation is also an advantage and should preferably be green in colour. Although the current carried by the bonding system will not normally exceed 1 amp, the cable sizes should be generous as shown in the table below:

| Length of run to Zinc Anode | Suggested cable size |
|-----------------------------|---------------------------------------|
| Up to 30 feet | 7 strand / 0.85mm (4mm ²) |
| 30 - 40 feet | 7 strand / 1.04mm (6mm ²) |

As many of the connections may be splashed with sea water they should be soldered wherever possible and clamped elsewhere, with the joint protected from corrosion by neoprene paint, or a similar material, to exclude water.

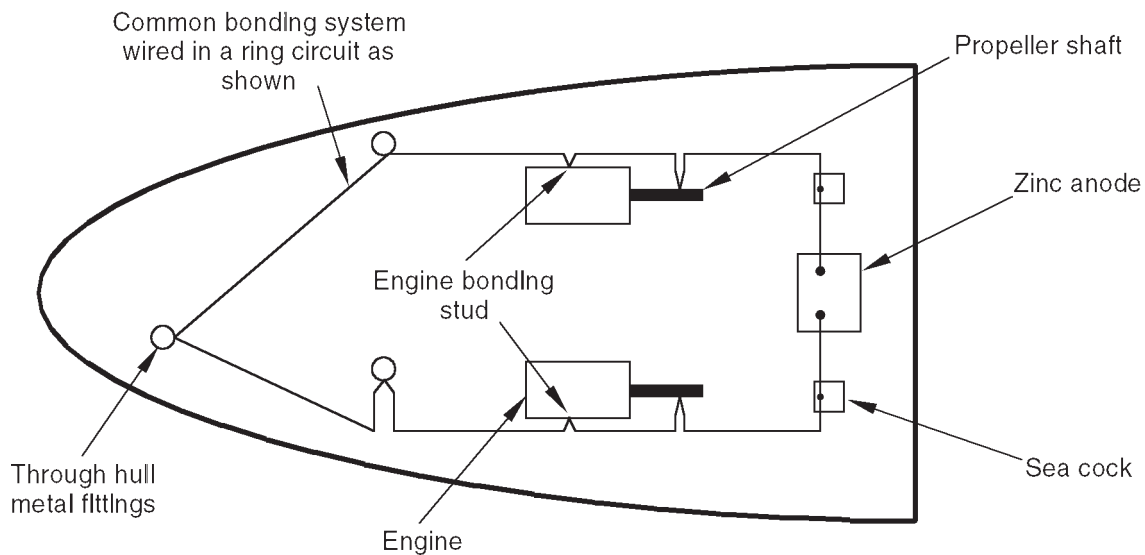

(c) It is important to include the propeller shaft in the bonding system, as the electrical path through the gearbox is not effective due to the gearbox oil acting as an insulator. The electrical connection to the shaft may be made by means of graphite brushes riding on the shaft or a braided battery strap may be used as illustrated below.

In either case the shaft earthing system should be connected to the bonding system to which the engine and the shaft log (if metal) are also connected.

Note: Strap should make contact with 90° of shaft circumference.

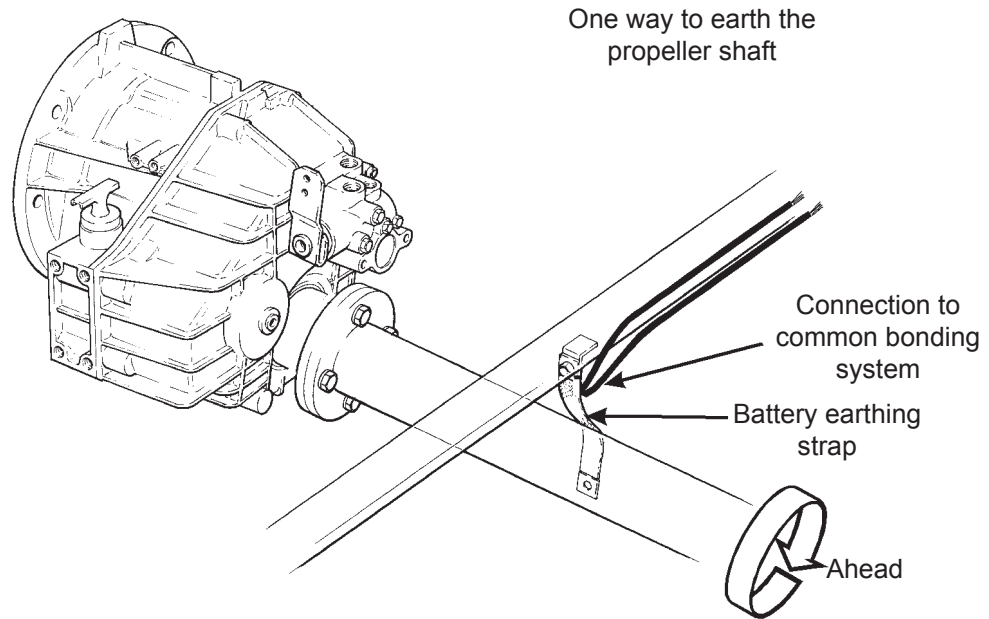

(d) Before the boat enters service the effectiveness of the bonding and sacrificial Zinc anode system should be tested, both when at rest and with all systems (including engines) in operation, by a specialist in this field.

Note: This section on bonding covers a typical system and has been included for guidance purposes only. It may not be appropriate for your boat. As installations vary it is advised that specific recommendations from a specialist in the subject of electrolytic corrosion are obtained.

Engine Controls

It is recommended that a Morse single lever system is used to control engine speed and gearbox engagement.

8.1 M300Ti, and M265Ti Engines

These engines are equipped with an electric stop solenoid as standard, but a piano wire stop cable may also be fitted, as shown below.

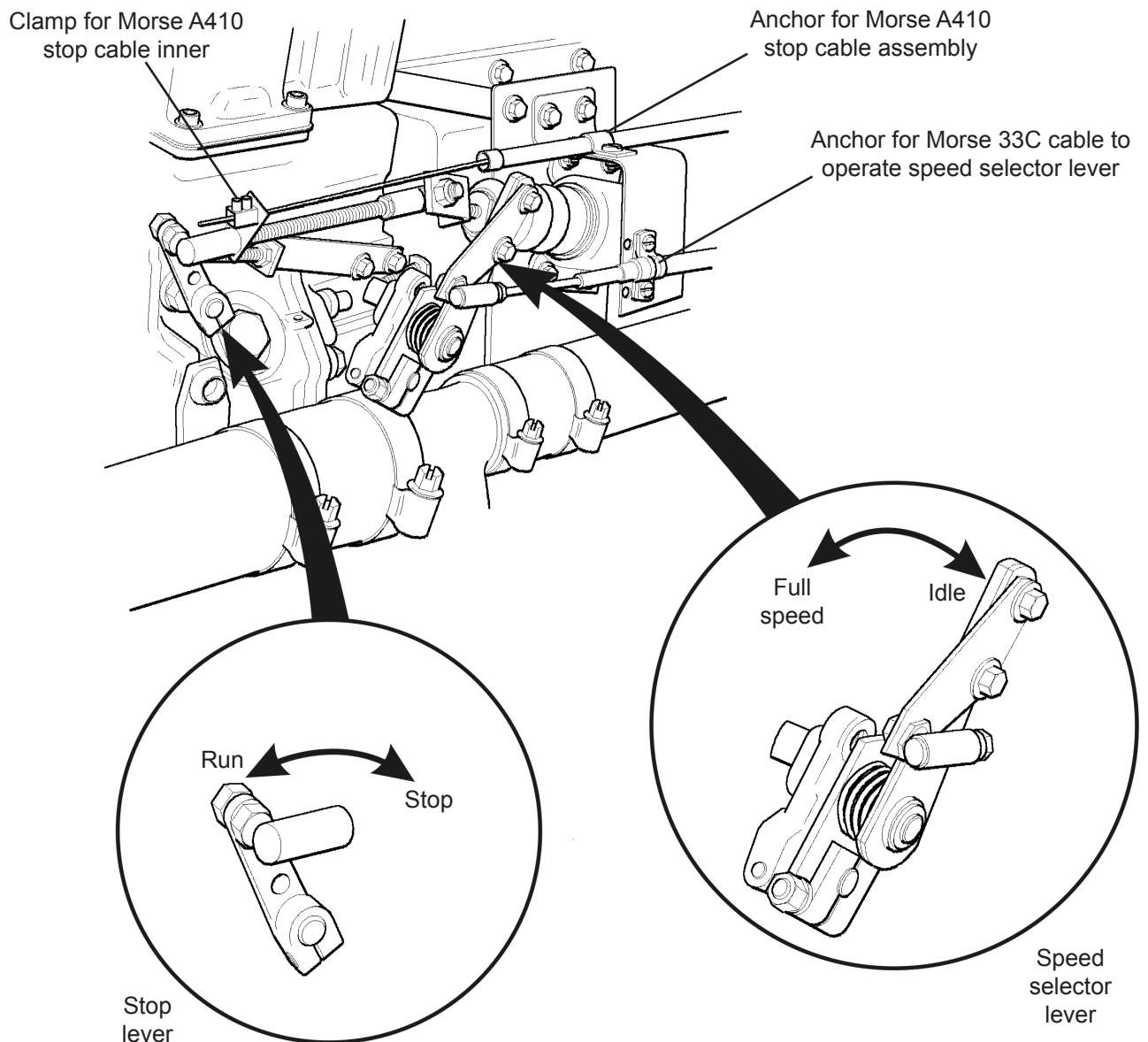

8.2 M225Ti, M215C and M185C Engines

The engine is supplied with connections to suit a Morse 33C cable. Figure 1 shows the position of the speed selector lever on the injection pump, and the anchor for the cable outer sleeve.

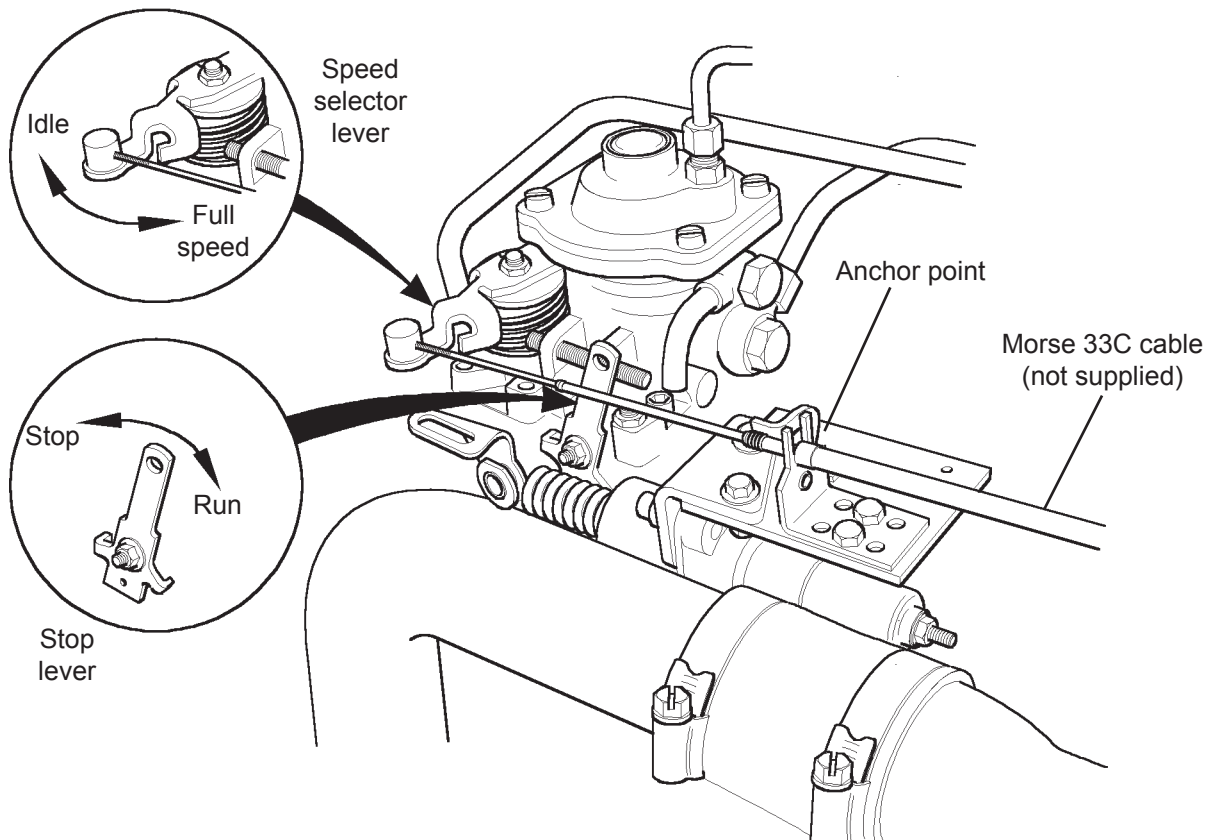

Figure 1 - Speed selector lever and stop lever.

Although an electric stop is fitted as standard equipment, in some cases a mechanical stop mechanism may be required. The injection pump is fitted with a stop lever, identified in figure 1, which may be operated remotely if required, using a piano wire type cable assembly.

Gearboxes supplied at the time that the engine is purchased will be fitted with connections to suit the Morse 33C cables.

8.3 M135 and M130C Engines

Figure 4 shows the position of the speed selector lever on the injection pump.

An electric stop is fitted as standard equipment, but a mechanical stop is also supplied. The injection pump is fitted with a stop lever, identified in figure 2, which may be connected by a piano wire type cable assembly to a position near the boat operator.

Gearboxes supplied at the time that the engine is purchased will be fitted with connections to suit Morse 33C cables.

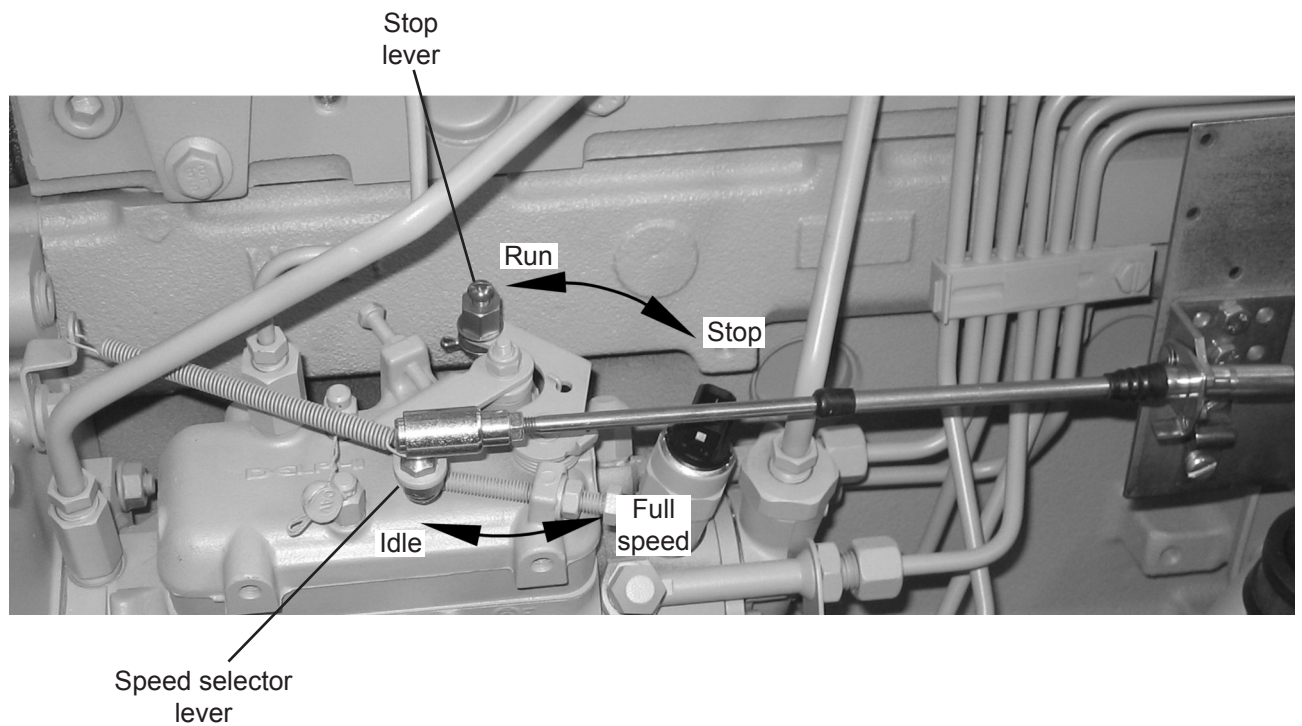

Figure 4 - Speed selector lever and stop lever

8.4 M115T and M92 Engines

Figure 2 shows the position of both the speed selector and manual stop lever on the injection pumps fitted to the M115T and M92 engines.

An electric stop solenoid is provided as standard equipment, but the mechanical stop lever, which is intended for remote operation by a piano wire type cable assembly, is an alternative means of stopping the engine and it is independent of electrical supply. The manual stop lever is, therefore, a back-up control to be used in the rather remote eventuality of the failure of the electric stop to work. It is recommended that it is connected, with the cable arranged so that it can be operated without opening the engine box (in case of fire)

Gearboxes supplied at the time that the engine is purchased will be fitted with connections to suit Morse 33C cables.

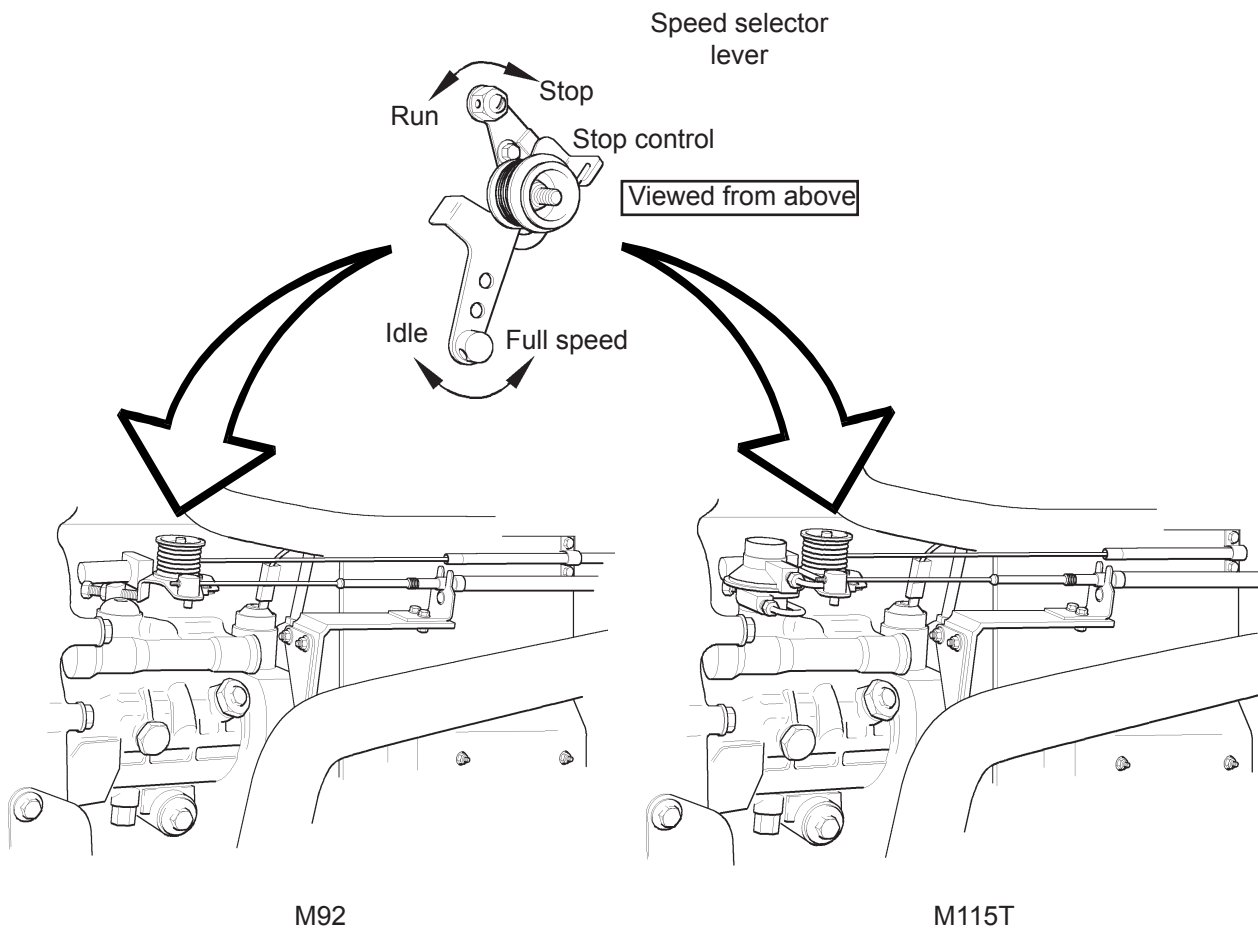

Figure 2 - Speed selector lever and stop lever

8.5 M92B Engines

Figure 3 shows the position of the speed selector lever on the injection pump fitted to the M92B engine.

An electric stop solenoid is provided as standard equipment.

Gearboxes supplied at the time that the engine is purchased will be fitted with connections to suit Morse 33C cables.

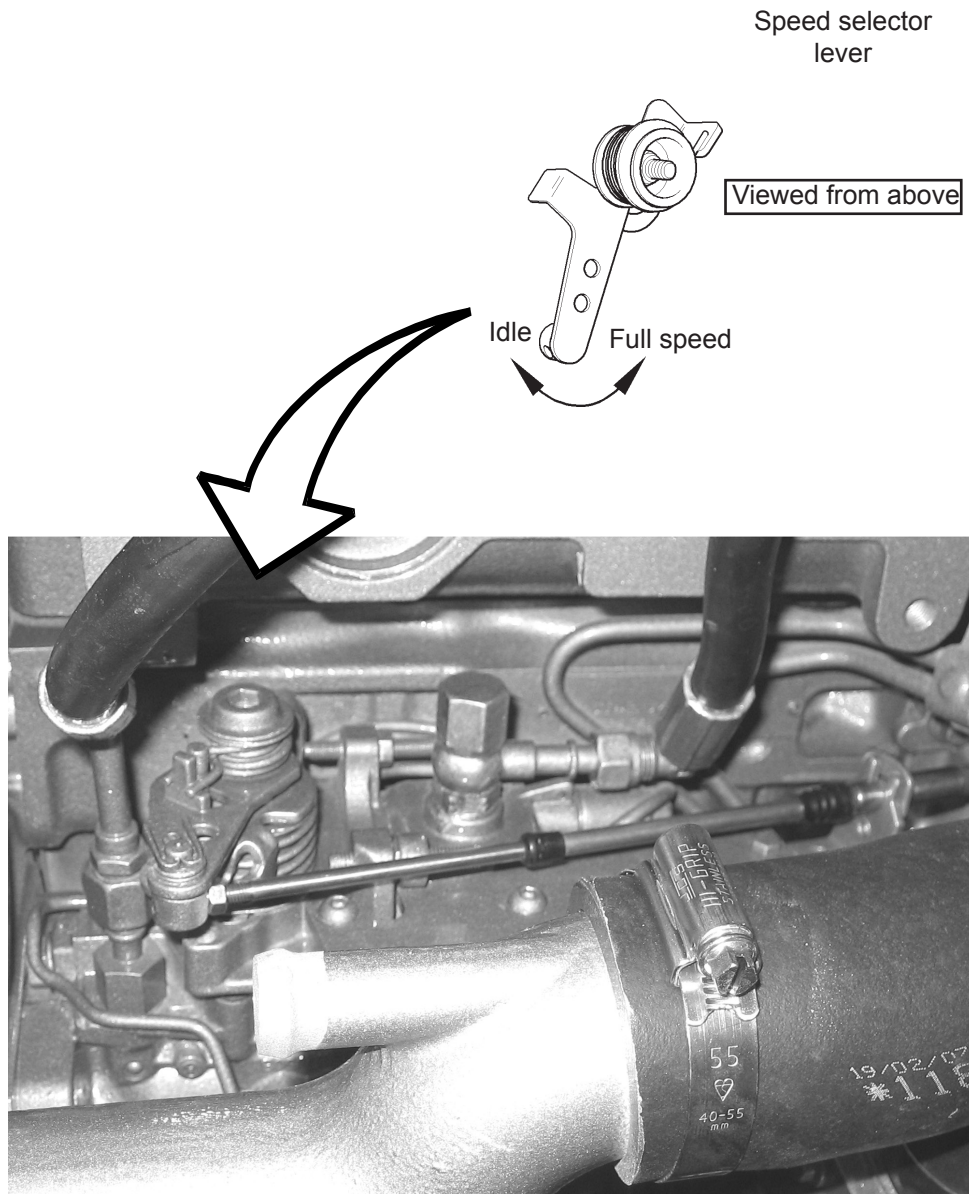

Figure 3 - Speed selector lever

Provision for Power Take-off

The ability to drive additional equipment from the crankshaft nose varies according to the engine model, as shown in the table below:

| Engine Models | Maximum PTO capability including both axial and belt drives | Maximum belt drive power |
|---|--|---|
| M92/M115T M130C/M135 | Full engine power | 6 kW |
| M185C | 59 kW at up to 1000 rev/min 79..... 1200 73..... 1400 60..... 1600 70..... 1800 79..... 2000 89..... 2200 98..... 2400 103..... 2500 | 6 kW |
| M215C/M225Ti | Full power at up to 1200 rev/min 80 kW 1400 62..... 1600 62..... 1800 84..... 2000 93..... 2200 104..... 2400 110..... 2500 | 6 kW |
| M265Ti | 14 kW | 8 kW at up to 2000 rev/min 5 kW above 2000 rev/min |
| M300Ti | 8 kW at up to 1800 rev/min | 8 kW at up to 1800 rev/min |
| Note: Above 1800 rev/min, no additional equipment should be driven by a M300Ti | | |

Note: i) Maximum recommended offtake 2 kW per belt.

ii) Multiple belt driven accessories should as far as possible be distributed evenly on either side of the engine to minimise side loads

iii) Customers wanting to fit a nonstandard drive pulley or coupling, should ensure the inertia of the added components does not exceed 0.0313 kg/m².

iv) If you are in any doubt, please contact your distributor.

Axial Drives

A Fenner F80 tyre type coupling should be used, and can be supplied with the engine.

Warning! Please refer to the manufacturers guidelines when working with this product.

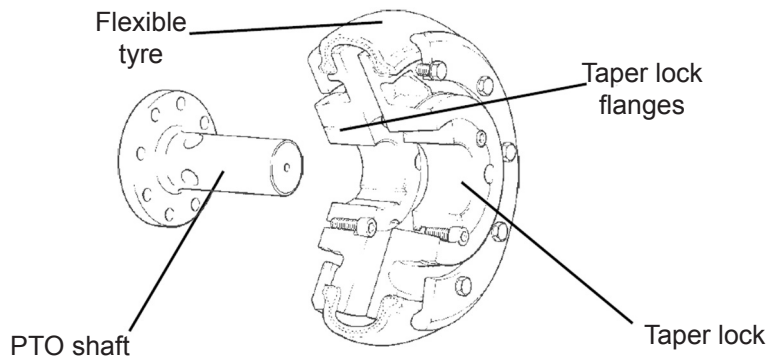

Figure 1 - The Fenner F80 coupling.

Belt Drives

Standard options are:-

Either a Fenner 5" A section pulley with three grooves.

or

A Fenner 5" B section pulley with two grooves.

In this case the maximum power which can be taken will be limited by the belts, and it will be necessary to calculate for marginal applications.

Caution: Additional inertia must not be added to the P.T.O. shaft without specialist advice. Consult your distributor if you need advice about nonstandard drive arrangements.

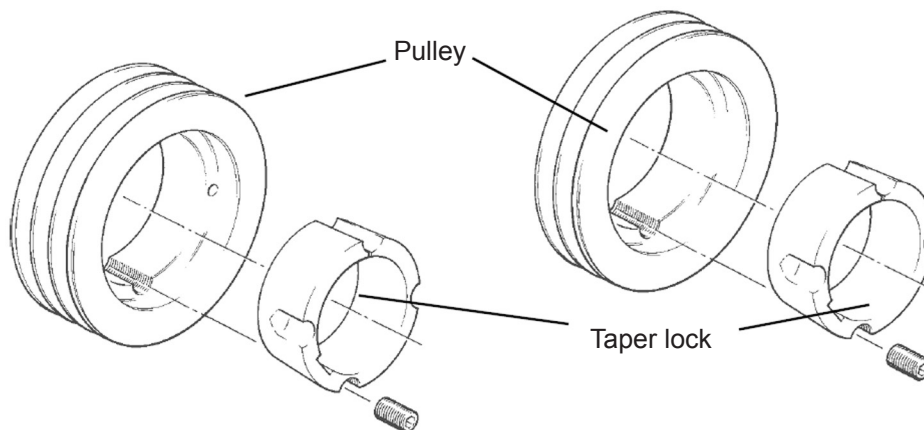
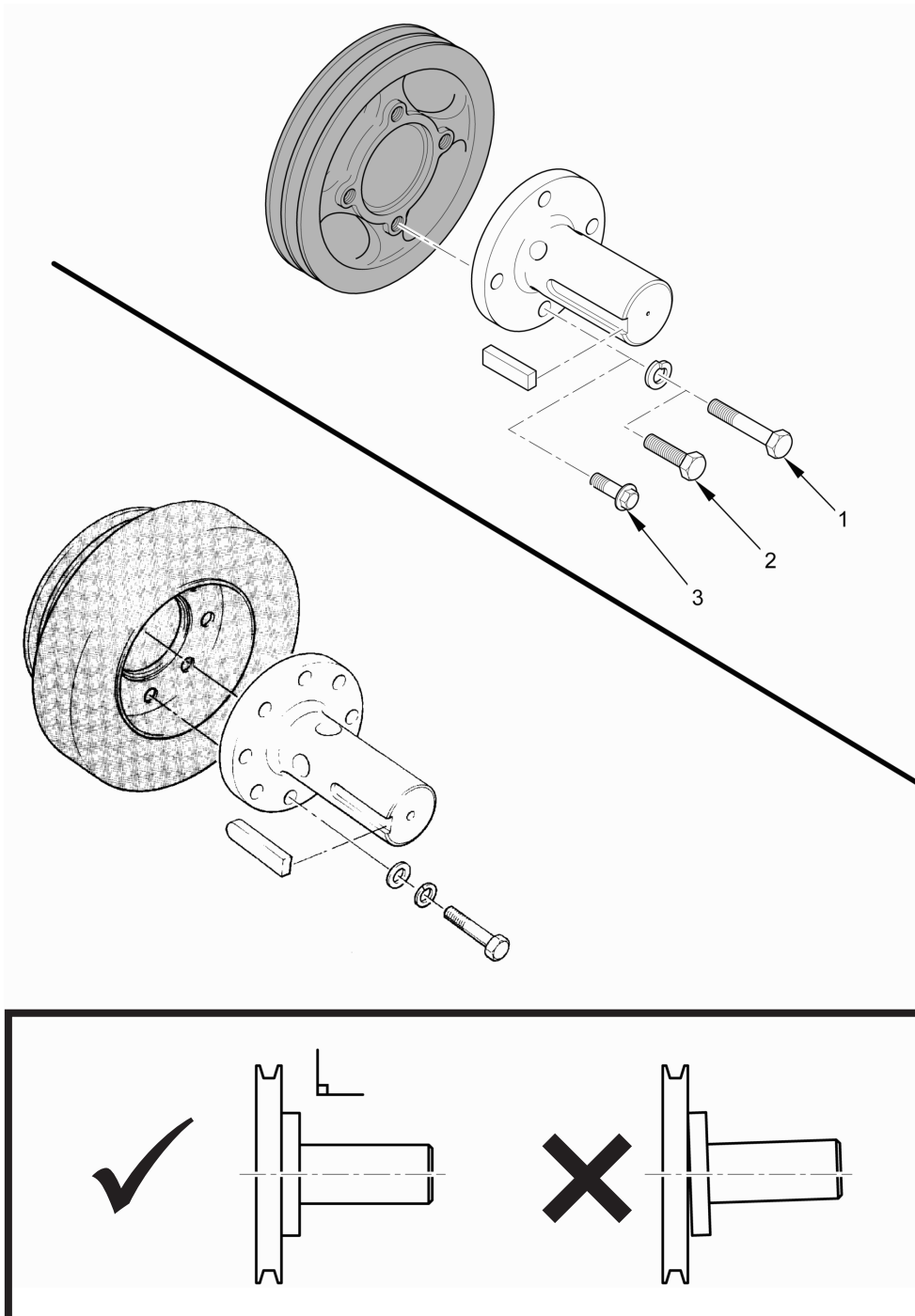

Figure 2 - The Fenner 5" A-section with three grooves.

Figure 3 - The Fenner 5" B-section with two grooves.

PTO Fitting Instructions

| Key | Size | Torque |
|-----|-------|--------|
| 1 | M12 | 100 Nm |
| 2 | 7/16" | 70 Nm |
| 3 | M10 | 55 Nm |



Note: Fitting the PTO should be undertaken by a qualified marine engineer.

Warning! For safety reasons, all moving parts should be shielded by a guard.

Electro Mechanical Bilge Pump

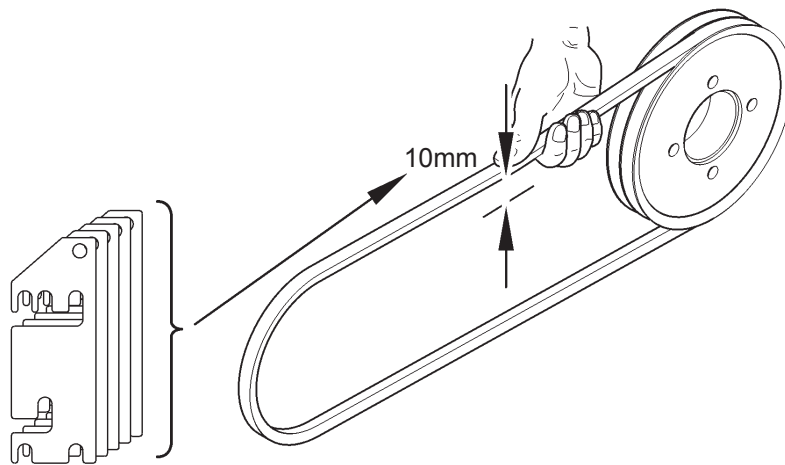
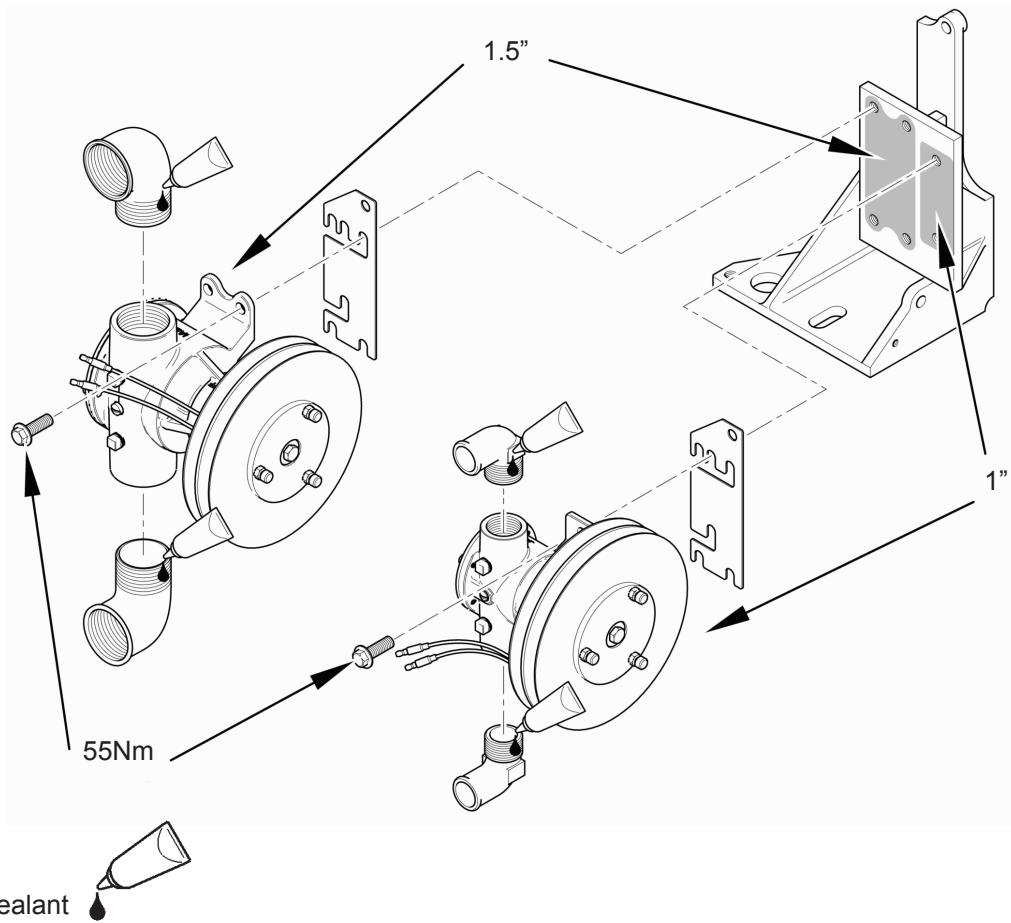

Note: Fitting the electro mechanical bilge pump should be undertaken by a qualified marine engineer.

Warning! For safety reasons, all moving parts should be shielded by a guard.

Calorifier and Block Heater Connections

10.1 Calorifier

Fittings are available to allow a calorifier to be connected to the engine, as shown in figure 1. The fittings may be ordered as part of the engine assembly, or as loose parts to be fitted later.

The hose connections to the calorifier must be of a radiator or heater hose quality, and must be installed so that chafing will not occur.

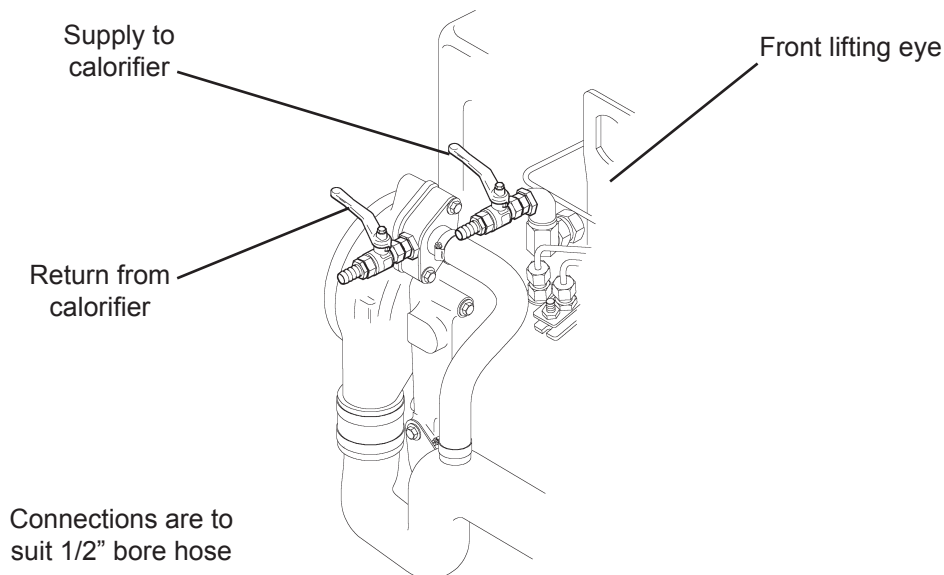

Figure 1a - Calorifier fittings for 6 cylinder engines.

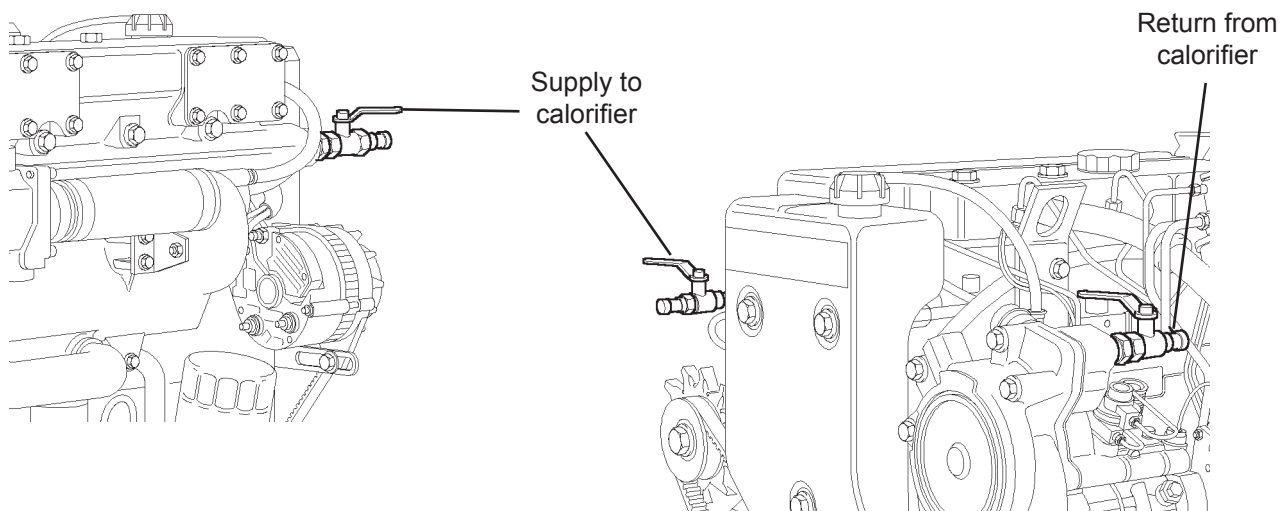

Figure 1b - Calorifier fittings for M92 and M115T

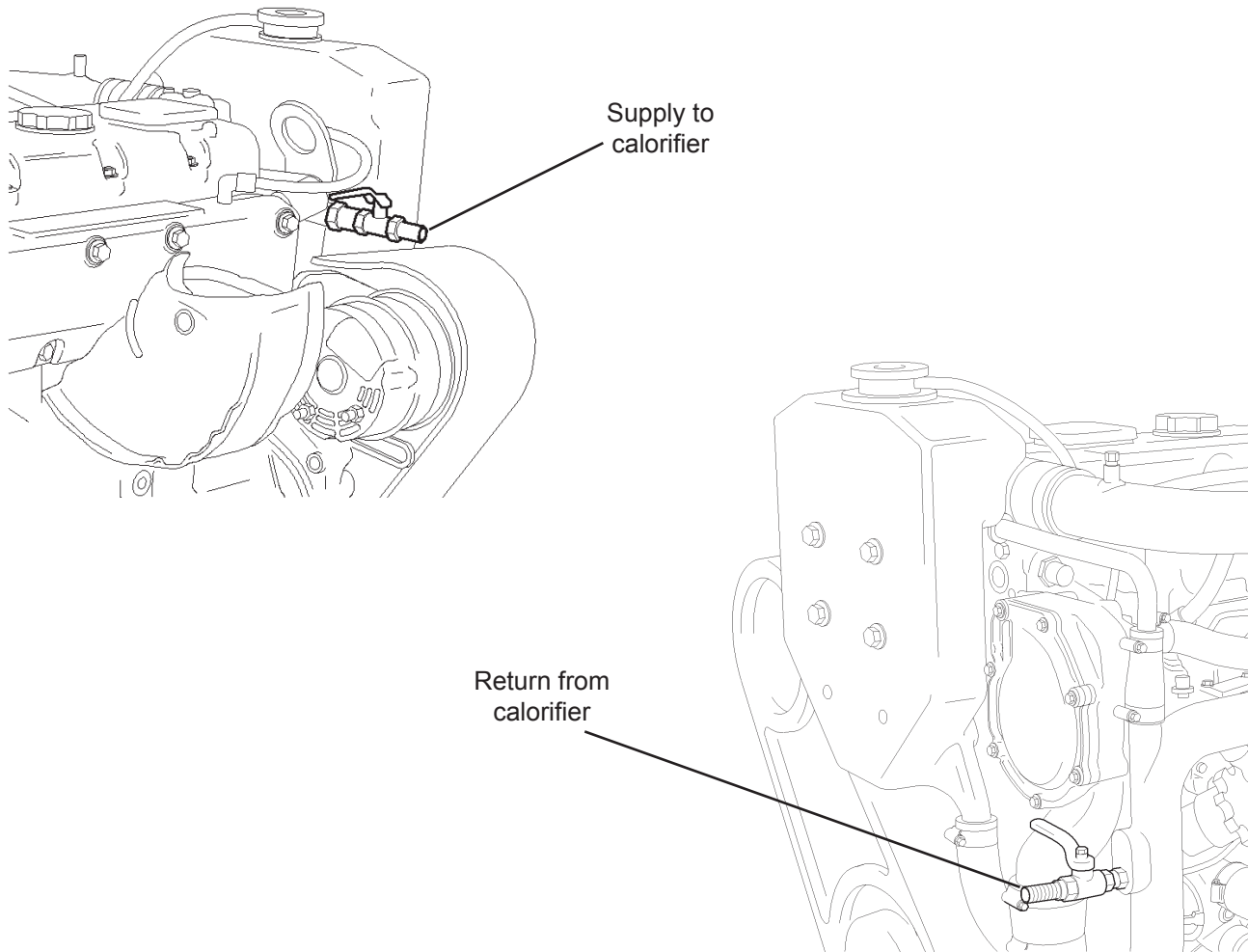

Figure 1b - Calorifier fittings for M92B M92 and M115T.

Caution: The hoses connecting the calorifier to the engine are part of the closed engine cooling system. Failure of a hose will lead to the engine overheating!

10.2 Block Heater - for 6 cylinder engine models

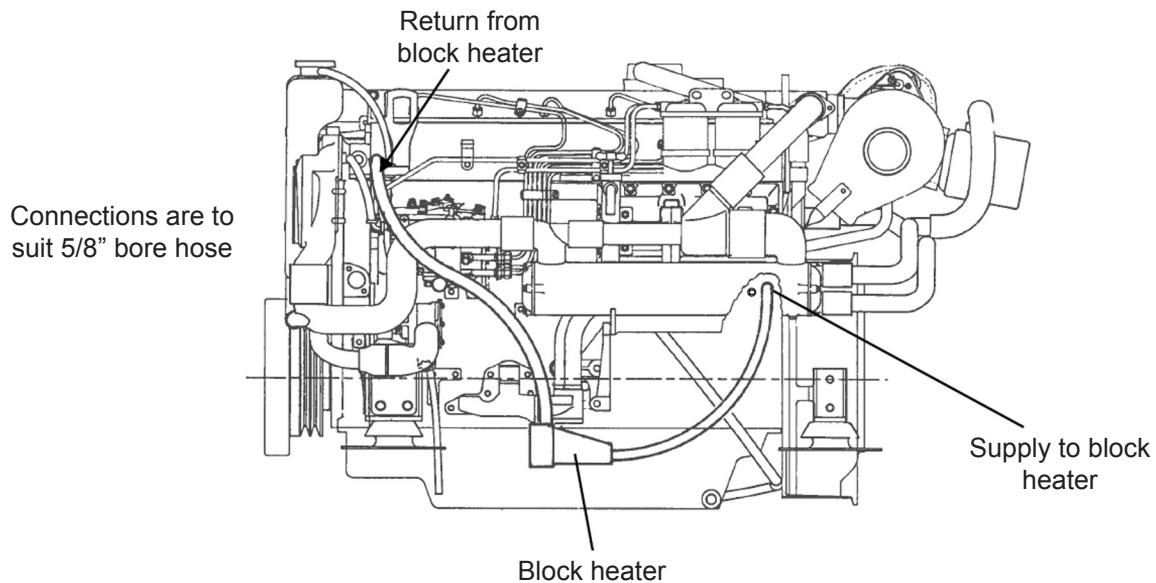

Figure 2 - Block heater connection points.

A mains powered cylinder block heater may be fitted to keep the engine warm when the boat is stored in low temperatures. A suitable heater may be ordered as part of the engine assembly, or may be fitted later.

Figure 2 shows the connection points, the supply being taken from a hole in the cylinder block tapped 1/4" - 18 NPSI and the return from a hole in the cylinder head tapped 1/2" - 14 NPSI.

For most purposes a 500W heater will be satisfactory. If the heater is ordered at the same time as the engine, it will be attached to the engine. If fitted later it may be more convenient to mount the heater on the engine bearer.

The hose connections to the block heater must be of a radiator or heater hose quality, and must be installed so that chafing will not occur.

Caution: *The hoses connecting the block heater to the engine are part of the closed engine cooling system. Failure of a hose will lead to the engine overheating!*

Reference Data

11.1 M300Ti and M265Ti Engines

| | Model M300Ti | Model M265Ti |
|---|--|---------------------|
| Basic Technical Data | | |
| Rated power | 286 ps (210.4 kW) | 253.4 ps (186.2 kW) |
| Rated engine speed | 2500 rpm | |
| Number of cylinders | 6 | |
| Cylinder arrangement | In-line | |
| Cycle | 4 Stroke | |
| Induction System | Waste gated turbocharger with charge air cooling | |
| Bore | 100 mm (3.937") | |
| Stroke | 127 mm (5.00") | |
| Compression Ratio | 17.5:1 | |
| Cubic Capacity | 5.995 Litre (365 in ³) | |
| Valves per cylinder | 2 | |
| Direction of Rotation | Anti-clockwise viewed from flywheel | |
| Firing Order | 1, 5, 3, 6, 2, 4 | |
| Total Weight (wet) | 635 kg (1400 lbs) engine only including alternator and starter. 718 kg (1583 lbs) engine with ZF IRM 220A gearbox | |
| Cooling System | | |
| | The coolant shown is mandatory for use in all climates to ensure that adequate levels of corrosion inhibitor are present. It will give frost protection to -37°C. | |
| Coolant | 50% inhibited ethylene glycol or 50% inhibited propylene glycol with 50% fresh clean water. | |
| Fresh Water Flow | 205 litre/min at 2500 rpm | |
| Coolant pump speed and method of drive | 1:1 Gear Driven | |
| System Capacity | 26.3 litres (5.6 gallons) | |
| Pressure cap setting | 50 kPa (7 psi) | |
| Protection switch setting | 96°C | |
| Sea water pump type | Jabsco gear driven model 080 full cam | |
| Sea water suggested inlet hose diameter | 32 mm Bore (1.25") | |

| | Model M300Ti | Model M265Ti |
|--|---|---|
| Sea cock | Full flow 25.4 mm (1 inch) | |
| Strainer | Raw water strainer must be included in suction side of the circuit | |
| Maximum sea water temperature | 38°C (100°F) | |
| Sea water flow | 123 l/min (27 galls/min) | |
| Fuel System | | |
| Recommended fuel specifications | BS2569 Class A ASTM D975 Number 2D | |
| Fuel injection pump | Bosch MW in-line with boost control and electric stop (energised to stop) | |
| Fuel lift pump | Bosch plunger type | |
| Fuel feed pressure (static) | 0.3 to 0.6 bar (5 to 8 psi) | |
| Governor type | Mechanical | |
| Pipe size: | | |
| • Supply - outside diameter | 10 mm (0.394") | |
| • Supply - bore | 8.4 mm (0.331") | |
| • Return - outside diameter | 10 mm (0.394") | |
| • Return - bore | 8.4 mm (0.331") | |
| Maximum lift pump lift | 1.8 m (6 ft) to bottom of tank suction pipe | |
| Maximum fuel lift pump | 127 mm (5 inches) Hg depression at inlet | |
| Fuel consumption at full power | 56.4 l/hr (12.4galls/hr) | 50 l/hr (11galls/hr) |
| Air Intake | | |
| Combustion airflow | 14.8m ³ /min (524ft ³ /min) | 13.8m ³ /min (488ft ³ /min) |
| Maximum engine compartment air temperature | 60°C | |
| Maximum air temperature at engine inlet | 52°C | |
| Ventilation - maximum engine room depression | 125 mm WG (5" WG) | |
| Suggested ventilation airflow including combustion air | 30m ³ /min (1050ft ³ /min) | 28m ³ /min (1000ft ³ /min) |

| | Model M300Ti | Model M265Ti |
|--|--|---|
| Minimum cross section of air duct (per engine) | 910cm ² (142sq ins) for hot climates 455cm ² (71sq ins) for temperate climates | 806cm ² (126sq ins) for hot climates 406cm ² (63sq ins) for temperate climates |
| Exhaust | | |
| Exhaust gas flow | 43.1m ³ /min (1520ft ³ /min) | 36.4m ³ /min (1290ft ³ /min) |
| Maximum restriction measured within (305mm) 12" of turbocharger outlet | 10.2kPa (3.0"Hg) | |
| Recommended pipe bore (wet exhaust) | 127mm (5.0") | |
| Recommended pipe bore (dry) | 76.2mm (3.0") | |
| Minimum rise from sea level to exhaust outlet centre-line | 203mm (8.0") | |
| Lubricating System | | |
| Recommended lubricating oil | API CF-4/SE or CCMC D5 | |
| Sump capacity maximum | 15 litres (3.3 gallons) | |
| Maximum installation angle plus planing angle for continuous operation | 17° engine front up plus 3° rise 5° nose down plus 3° rise, with special kit of parts. 30° heel when motor sailing | |
| Oil pressure in operating speed range (steady state) | 2.5 to 3.5 bar (36 to 50 psi) | |
| Low oil pressure switch setting | 0.8 bar (12 psi) | |
| Electrical System | | |
| Alternator | Lucas A127 40 amp (24 volt) or 70 amp (12 volt) | |
| Starter type | Lucas S115 | |
| Number of teeth in flywheel | 126 | |
| Number of teeth on starter | 10 | |
| Cold Start Limits | | |
| Minimum cold start temperature (with aid) | -15°C (5°F) | |
| Batteries for minimum cold start | 2 off 12 volt - each 520 amps to BS 3911 or 2 off 12 volt - each 800 amps to SAE J537 | |

11.2 M225Ti, M215C and M185C Engines

| | Model M225Ti/M215C | Model M185C |
|--|---|-----------------|
| Basic Technical Data | | |
| Rated power | 213 PS (156.6 kW) | 190 PS (140 kW) |
| Rated engine speed | 2500 rev/min | 2100 rev/min |
| Number of cylinders | 6 | |
| Cylinder arrangement | In-line | |
| Cycle | 4 stroke | |
| Induction system | Waste gated turbocharger with charge air cooler | |
| Bore | 100 mm (3.937") | |
| Stroke | 127 mm (5.00") | |
| Compression ratio | 16:1 | |
| Cubic capacity | 6.00 litres (365.0 in ³) | |
| Valves per cylinder | 2 | |
| Direction of rotation | Anti-clockwise viewed on flywheel | |
| Firing order | 1, 5, 3, 6, 2, 4 | |
| Total weight (wet) | 609 kg (1342 lb) engine only including starter and alternator. | |
| Cooling System | The coolant shown below is mandatory for use in all climates to ensure that adequate levels of corrosion inhibitor are present. It will give frost protection to -37°C. | |
| Coolant | 50% inhibited ethylene glycol or 50% inhibited propylene glycol with 50% fresh clean water | |
| Fresh water flow | 205 l/min (45 galls/min) at 2500/min 159 l/min (35 galls/min) at 2100 rev min | |
| Coolant pump speed and method of drive. | 1:1 Gear driven | |
| System capacity | 25.3 litres (5.6 gallons) | |
| Pressure cap setting | 50 kPa (7 psi) | |
| Protection switch setting | 96°C | |
| Sea water pump type | Jabsco gear driven model 25.4 mm (1") full cam. | |
| Sea water suggested inlet hose diameter. | 32 mm (1.25") | |
| Sea cock | Full flow 25.4mm (1.00") | |

| | Model M225Ti/M215C | Model M185C |
|---|---|--|
| Strainer A raw water strainer must be included in the suction side of the circuit. | | |
| Maximum sea water temperature. | | 38°C (100°F) |
| Sea water flow | 123 l/min (27galls/min) | 109 l/min (24galls/min) |
| Fuel System | | |
| Recommended fuel specifications. | BS2869 Class A2 ASTM D 975 Number 2D. | |
| Fuel injection pump | Bosch rotary with boost control and electric stop. (energised to stop). | |
| Fuel lift pump | AC Delco type LU | |
| Fuel feed pressure (static) | 0.3 to 0.6 bar (5 to 8 psi) | |
| Governor type | Mechanical | |
| Pipe size: | | |
| • Supply - Outside diameter | 7.9 mm (0.315") | |
| • Supply - Bore | 6.53 mm (0.257") | |
| • Return - Outside diameter | 6.3 mm (0.25") | |
| • Return - Bore | 4.93 mm (0.194") | |
| Maximum lift pump lift | 1.8 m (6 ft) to bottom of tank suction pipe. | |
| Maximum fuel lift pump depression at inlet. | 127 mm (5") Hg | |
| Fuel consumption at full power. | 43 l/hr (9.4galls/hr) | 35 l/hr (7.7galls/hr) |
| Air Intake | | |
| Combustion airflow | 13.0 m ³ /min (460 ft ³ /min) | 10.76 m ³ /min (380 ft ³ /min) |
| Maximum engine compartment air temperature. | 60°C | |
| Maximum air temperature at engine inlet. | 52°C | |
| Ventilation - maximum engine room depression. | 125mm WG (5"WG) | |
| Suggested ventilation airflow including combustion air. | 25m ³ /min (1000ft ³ /min) | |
| Minimum cross section of air duct (per engine). | 640 cm ² (100 sq ins) for hot climates. 320 cm ² (50 sq ins) for temperate climates. | |

| | Model M225Ti/M215C | Model M185C |
|---|---|---------------|
| Exhaust | | |
| Exhaust gas flow | 35.08 m ³ /min (1240 ft ³ /min). | |
| Maximum restriction measured within(305 mm) | | |
| 12" of turbocharger outlet. | 10.2 kPa (3.0" Hg) | |
| Recommended pipe bore (wet exhaust). | 127 mm (5.0") | 100 mm (4.0") |
| Recommended pipe bore (dry). | 76.2 mm (3.0") | |
| Minimum rise from sea water level to exhaust outlet centreline. | 203 mm (8.0") | |
| Lubricating System | | |
| Recommended lubricating oil. | AP1 CD/SE CCMC D4 | |
| Sump capacity maximum | 15 litres (3.3 gallons) | |
| Maximum installation angle plus planing angle for continuous operation. | 17° engine front up + 3° rise. 5° nose down + 3° rise with special kit of parts, 30° heel when motor sailing. | |
| Oil pressure, in operating speed range (steady state). | 2.8 to 3.8 bar (40 to 55 psi) | |
| Low oil pressure switch setting. | 0.8 bar (12 psi) | |
| Electrical System | | |
| Alternator | Lucas A127 40A (24V) or 70A (12V). | |
| Starter type | Lucas S115 | |
| Number of teeth in flywheel | 126 | |
| Number of teeth on starter | 10 | |
| Cold Start Limits | | |
| Minimum cold start temperature (with aid). | -15°C (5°F) | |
| Batteries for minimum cold start | 2 off - 12V 315 Amps to BS3911 or 2 off - 12V, 535 amps to SAE J537 | |

11.3 M135, and M130C Engines

| | Model M135 | Model M130C |
|--|---|-------------|
| Basic Technical Data | | |
| Rated power | 130 PS (96 kW) | |
| Rated engine speed | 2600 rev/min | |
| Number of cylinders | 6 | |
| Cylinder arrangement | In-line | |
| Cycle | 4 stroke | |
| Induction system | Naturally aspirated | |
| Bore | 100 mm (3.937") | |
| Stroke | 127 mm (5.00") | |
| Compression ratio | 16.5:1 | |
| Cubic capacity | 6.00 litres (365 in ³) | |
| Valves per cylinder | 2 | |
| Direction of rotation | Anti-clockwise viewed on flywheel | |
| Firing order | 1, 5, 3, 6, 2, 4 | |
| Total weight (wet) | 595 kg (1312 lb) engine only including starter and alternator. | |
| Cooling System | | |
| | The coolant shown below is mandatory for use in all climates to ensure that adequate levels of corrosion inhibitor are present. It will give frost protection to -37°C. | |
| Coolant | 50% inhibited ethylene glycol or 50% inhibited propylene glycol with 50% fresh clean water | |
| Fresh water flow | 213 litre/min (47 gall/min) at 2600 rev/min | |
| Coolant pump speed and method of drive. | 1:1 Gear driven | |
| System capacity | 25.3 litres (5.6 gallons) | |
| Pressure cap setting | 48 kPa (7 psi) | |
| Protection switch setting | 96°C | |
| Sea water pump type | Jabsco gear driven model 25.4 mm (1") full cam. | |
| Sea water suggested inlet hose diameter. | 32 mm (1.25") | |
| Sea cock | Full flow 25.4mm (1.00") | |
| Strainer | A raw water strainer must be included in the suction side of the circuit. | |

| | Model M135 | Model M130C |
|---|--|-------------|
| Maximum sea water temperature. | 38°C (100°F) | |
| Sea water flow | 127 l/min (28galls/min) | |
| Fuel System | | |
| Recommended fuel specifications. | BS2869 Class A2 ASTM D 975 Number 2D. | |
| Fuel injection pump | Stanadyne with electric stop. | |
| Fuel lift pump | AC Delco type LU | |
| Fuel feed pressure (static) | 33/55 kPa (5/8 psi) | |
| Governor type | Mechanical | |
| Pipe size: | | |
| • Supply - Outside diameter | 7.9 mm (0.315") | |
| • Supply - Bore | 6.53 mm (0.257") | |
| • Return - Outside diameter | 6.3 mm (0.25") | |
| • Return - Bore | 4.93 mm (0.194") | |
| Maximum lift pump lift | 1.8 m (6 ft) to bottom of tank suction pipe. | |
| Maximum fuel lift pump depression at inlet. | 127 mm (5") Hg | |
| Fuel consumption at full power. | 14.37 ml/sec | |
| Fuel consumption at full power | 28 l/hr (6.2 galls/hr) | |
| Air Intake | | |
| Combustion airflow | 6.5 m ³ /min (230 ft ³ /min) | |
| Maximum engine compartment air temperature. | 60°C (140°F) | |
| Maximum air temperature at engine inlet. | 52°C (125°F) | |
| Ventilation - maximum engine room depression. | 125mm WG (5"WG) | |
| Suggested ventilation airflow including combustion air. | 13m ³ /min (520ft ³ /min) | |
| Minimum cross section of air duct (per engine). | 320 cm ² (50 sq ins) | |

| | Model M135 | Model M130C |
|---|--|-------------|
| Exhaust | | |
| Exhaust gas flow | 20 m ³ /min (706 ft ³ /min). | |
| Maximum restriction measured within(305 mm) 12" of turbocharger outlet. | 10.2 kPa (3.0" Hg) | |
| Recommended pipe bore (wet exhaust). | 76 mm (3.0") | |
| Recommended pipe bore (dry). | 63.5 mm (2.5") | |
| Minimum rise from sea water level to exhaust outlet centreline. | 203 mm (8.0") | |
| Lubricating System | | |
| Recommended lubricating oil. | AP1 CC/SE API CD/SE or CCMC D4 can also be used but are not recommended for first 20/40 hours | |
| Sump capacity maximum | 15 litres (3.3 gallons) | |
| Maximum installation angle plus planing angle for continuous operation. | 17° engine front up + 3° rise. 5° nose down + 3° rise with special kit of parts, 30° heel | |
| Oil pressure, in operating speed range (steady state). | 280 kN/m ² (40 psi) | |
| Low oil pressure switch setting. | 83 kN/m ² (12 psi) | |
| Electrical System | | |
| Alternator | Lucas A127 40A (24V) or 70A (12V). | |
| Starter type | CAV CA45H | |
| Number of teeth in flywheel | 126 | |
| Number of teeth on starter | 10 | |
| Cold Start Limits | | |
| Minimum cold start temperature (with aid). | -15°C (5°F) | |
| Batteries for minimum cold start | 2 off - 315 Amps to BS3911 or 2 off - 535 Amps to SAE J537 | |

11.4 M115T, and M92 Engines

| | Model M115T | Model M92 |
|---|---|---|
| Basic Technical Data | | |
| Rated power | 80 kW (107 bhp) | 63.5 kW (85 bhp) |
| Rated engine speed | 2400 rev/min | |
| Number of cylinders | 4 | |
| Cylinder arrangement | Vertical in-line | |
| Cycle | 4 stroke | |
| Induction system | Turbocharged | Naturally aspirated |
| Combustion system | Fastram direct injection | |
| Bore | 100 mm (3.937") | 103.0 mm (4.055 in) |
| Stroke | 127 mm (5.00") | 127 mm (5.00") |
| Compression ratio | 17.25:1 | 18.5:1 |
| Cubic capacity | 3.99 litres (243 in ³) | 4.23 litres (258 in ³) |
| Valves per cylinder | 2 | |
| Direction of rotation | Anti-clockwise viewed on flywheel | |
| Firing order | 1, 3, 4, 2 | |
| Total weight (wet) | 422.6 kg (933 lbs) | 417.8 kg (921 lbs) |
| | engine only including starter and alternator | |
| Cooling System | The coolant shown below is mandatory for use in all climates to ensure that adequate levels of corrosion inhibitor are present. It will give frost protection to -37°C. | |
| Coolant | 50% inhibited ethylene glycol or 50% inhibited propylene glycol with 50% fresh clean water | |
| Fresh water flow | 202 litre/min (44.4 gall/min) at 2400 rev/min | |
| Coolant pump speed and method of drive. | Gear driven | |
| System capacity | 19 litres (4.18 gallons) | |
| Pressure cap setting | 50 kPa (7 psi) | |
| Protection switch setting | 96°C | |
| Sea water pump type | Jabsco gear driven model 25.4 mm (1") full cam. | Jabsco gear driven models 25.4 mm (1") 2/3 cam |

| | Model M115T | Model M92 |
|---|--|---|
| Sea water strainer | A strainer must be included in the suction side of the circuit | |
| Maximum sea water temperature. | 38°C (100°F) | |
| Sea water flow | 109 l/min (24 galls/min) | 98 l/min (21.5 galls/min) |
| Fuel System | | |
| Recommended fuel specifications. | BS2869 Class A2 ASTM D 975 Number 2D. | |
| Fuel injection pump | Lucas rotary with boost control. Cold start advance and with electric stop (energise to stop) manual override stop. | Lucas rotary. Cold start advance and with electric stop (energise to stop) manual override stop. |
| Fuel lift pump | Superpar (mechanical) | |
| Governor type | Mechanical | |
| Pipe size: | | |
| • Supply - Outside diameter | 8 mm (0.313") | |
| • Supply - Bore | 6.5 mm (0.26") | |
| • Return - Outside diameter | 6.35 mm (0.25") | |
| • Return - Bore | 4.93 mm (0.194") | |
| Maximum lift pump lift | 1.5 m (60 in) to bottom of tank suction pipe. | |
| Maximum fuel lift pump depression at inlet. | 127 mm (5") Hg | |
| Fuel consumption at full power. | 22.7 l/hr (5 galls/hr) | 17.94 l/hr (3.95 galls/hr) |
| Air Intake | | |
| Combustion airflow | 6.64 m ³ /min (235 ft ³ /min) | 4.6 m ³ /min (162 ft ³ /min) |
| Maximum engine compartment air temperature. | 60°C (140°F) | |
| Maximum air temperature at engine inlet. | 52°C (125°F) | |
| Ventilation - maximum engine room depression. | 125mm WG (5"WG) | |
| Suggested ventilation airflow including combustion air. | 13.5 m ³ /min (480 ft ³ /min) | 9.20 m ³ /min (324 ft ³ /min) |

| | Model M115T | Model M92 |
|---|--|--|
| Minimum cross section of air duct (per engine). | 174 cm ² (27 sq ins) temperate climates 348 cm ² (54 sq ins) for hot climates | 139 cm ² (21.5 sq ins) temperate climates 277 cm ² (42.9 sq ins) for hot climates |
| Exhaust | | |
| Exhaust gas flow | 16.4 m ³ /min (579 ft ³ /min). | 15.1 m ³ /min (533 ft ³ /min). |
| Maximum restriction measured within(305 mm) 12" of turbocharger outlet. | 10.2 kPa (3.0" Hg, 76 mm) | |
| Recommended pipe bore (wet exhaust). | 88.9 mm (3.5") | 76 mm (3") |
| Minimum rise from sea water level to exhaust outlet centreline. | 203 mm (8.0") | |
| Lubricating System | | |
| Recommended lubricating oil. | AP1 CG4, ACEA E3 | |
| Sump capacity maximum | 7 litres (12.3 pints) | |
| Maximum installation angle plus planing angle for continuous operation. | 20° nose up | |
| Oil pressure, in operating speed range (steady state). | 3.0 to 3.7 bar (43.5 to 54 lbf/in ²) | |
| Low oil pressure switch setting. | 0.8 bar (12 lbf/in ²) | |
| Electrical System | | |
| Alternator (insulated) | Prestolite A127 40A (24V) or 70A (12V). | |
| Starter type (earth return) | Prestolite M127 - 12 volt only | |
| Starter type (insulated) | Prestolite S115 - 12 volt and 24 volt | |
| Number of teeth in flywheel | 126 | |
| Number of teeth on starter | 10 | |
| Cold Start Limits | | |
| Minimum cold start temperature (without aid). | -10°C | |
| Batteries for minimum cold start | 12 volt system - 1 off 12 volt 520 amp to BS3911 24 volt system - 2 off 12 volt 440 amp to BS3911 | |

11.5 M92B Engines

| Model M92B | |
|---|---|
| Basic Technical Data | |
| Rated power | 64 kW (85.6 bhp) |
| Rated engine speed | 2400 rev/min |
| Number of cylinders | 4 |
| Cylinder arrangement | Vertical in-line |
| Cycle | 4 stroke |
| Induction system | Naturally aspirated |
| Combustion system | Direct injection |
| Bore | 105.0 mm (4.13 in) |
| Stroke | 127 mm (5.00") |
| Compression ratio | 18.23:1 |
| Cubic capacity | 4.4 litres (269 in ³) |
| Valves per cylinder | 2 |
| Direction of rotation | Anti-clockwise viewed on flywheel |
| Firing order | 1, 3, 4, 2 |
| Total weight (wet) | 423 kg (933 lbs) engine only including starter and alternator |
| Cooling System | The coolant shown below is mandatory for use in all climates to ensure that adequate levels of corrosion inhibitor are present. It will give frost protection to -37°C. |
| Coolant | Extended life coolant 50/50 mix. |
| Fresh water flow | 193 litre/min (42.5 UK gall/min) at 2400 rev/min |
| Coolant pump speed and method of drive. | Gear driven |
| System capacity | 19 litres (4.18 gallons) |
| Pressure cap setting | 50 kPa (7 psi) |
| Protection switch setting | 96°C |
| Sea water pump type | Jabsco gear driven model, 25.4 mm (1") full cam. |

| Model M92B | |
|---|--|
| Sea water strainer | A strainer must be included in the suction side of the circuit |
| Maximum sea water temperature. | 38°C (100°F) |
| Sea water flow | 98 l/min (21.5 UK galls/min) |
| Fuel System | |
| Recommended fuel specifications. | BS2869 Class A2 ASTM D 975 Number 2D. |
| Fuel injection pump | Bosch EPVE |
| Governor type | Mechanical |
| Pipe size: | |
| • Supply - Outside diameter | 8 mm (0.313") |
| • Supply - Bore | 6.5 mm (0.26") |
| • Return - Outside diameter | 6.35 mm (0.25") |
| • Return - Bore | 4.93 mm (0.194") |
| Maximum lift pump lift | 2m (78in) to bottom of tank suction pipe. |
| Maximum fuel lift pump depression at inlet. | 127 mm (5") Hg |
| Fuel consumption at full power. | 17.62 l/hr (3.88 galls/hr) |
| Air Intake | |
| Combustion airflow | 6.64 m ³ /min (235 ft ³ /min) 4.6 m ³ /min (162 ft ³ /min) |
| Maximum engine compartment air temperature. | 60°C (140°F) |
| Maximum air temperature at engine inlet. | 52°C (125°F) |
| Ventilation - maximum engine room depression. | 125mm WG (5"WG) |
| Suggested ventilation airflow including combustion air. | 8.4 m ³ /min (296 ft ³ /min) |
| Minimum cross section of air duct (per engine). | 139 cm ² (21.5 sq ins) temperate climates 277 cm ² (42.9 sq ins) for hot climates |

| Model M92B | |
|---|--|
| Exhaust | |
| Exhaust gas flow | 12.3 m ³ /min (434 ft ³ /min). |
| Maximum restriction measured within(305 mm) 12" of turbocharger outlet. | 15 kPa (4.43" Hg, 112 mm) |
| Recommended pipe bore (wet exhaust). | 76 mm (3") |
| Minimum rise from sea water level to exhaust outlet centreline. | 203 mm (8.0") |
| Lubricating System | |
| Recommended lubricating oil. | AP1 CG4/CH4, ACEA E3/E5 |
| Sump capacity maximum | 7 litres (12.3 pints) |
| Maximum installation angle plus planing angle for continuous operation. | 20° nose up |
| Oil pressure, in operating speed range (steady state). | 3.0 to 3.7 bar (43.5 to 54 lbf/in ²) |
| Low oil pressure switch setting. | 0.8 bar (12 lbf/in ²) |
| Electrical System | |
| Alternator (insulated) | Prestolite A128E 55A (24V) or 90A (12V). |
| Starter type (insulated) | Prestolite S115 - 12 volt and 24 volt |
| Number of teeth in flywheel | 126 |
| Number of teeth on starter | 10 |
| Cold Start Limits | |
| Minimum cold start temperature (without aid). | -10°C |
| Batteries for minimum cold start | 12 volt system - 1 off 12 volt 520 amp to BS3911 24 volt system - 2 off 12 volt 440 amp to BS3911 |

California

Proposition 65 Warning

Diesel engine exhaust and some of its constituents are known to the State of California to cause cancer, birth defects, and other reproductive harm.



Perkins[®]
Marine Power

All information in this document is substantially correct at time of printing and may be altered subsequently.

Part No. TPD 1317E issue 14

Produced in England ©2013 by Wimborne Marine Power Centre

Wimborne Marine Power Centre
22 Cobham Road,
Ferndown Industrial Estate,
Wimborne, Dorset, BH21 7PW, England.
Tel: +44 (0)1202 796000,
Fax: +44 (0)1202 796001
E-mail: Marine@Perkins.com

Web: www.perkins.com/Marine