

374F L

Hydraulic Excavator



Engine

Engine Model	Cat® C15 ACERT™
Power – ISO 14396 (metric)	362 kW (492 hp)
Power – ISO 9249 (metric)	352 kW (479 hp)

Drive

Maximum Travel Speed	4.1 km/h
Maximum Drawbar Pull	492 kN

Operating Weights

Minimum – Reach Configuration	70 970 kg
Maximum – Mass Configuration	75 170 kg

The 374F L is built to keep your production numbers up and your owning and operating costs down.

Not only does the machine's C15 ACERT engine meet EU Stage IV emission standards, but it does so while giving you all the power, fuel efficiency, and reliability you need to succeed.

Where the real power comes in is through the hydraulic system. You can literally move tons of material all day long with a great deal of speed and precision. In fact, the hydraulic system and engine work together to keep fuel consumption to an absolute minimum – all without impacting your productivity.

When you add in a quiet operator environment that keeps you comfortable and productive, service points that make your routine maintenance quick and easy, and multiple Cat work tools that help you take on a variety of jobs, you simply won't find a better 70-75 ton machine.

Contents

Reliable and Productive.....	4
Fuel Efficient.....	6
Easy to Operate.....	8
Durable Structures.....	10
Durable Linkages.....	11
Versatile.....	12
Integrated Technologies.....	14
Safe Work Environment.....	16
Serviceable.....	17
Sustainable.....	18
Complete Customer Care.....	18
Specifications.....	19
Standard Equipment.....	32
Optional Equipment.....	33
Notes.....	34







Reliable and Productive

Power to move your material with speed and precision

Hydraulic Horsepower, a Cat Advantage

Hydraulic horsepower is the actual machine power available to do work through implements and work tools. It's much more than just the engine power under the hood – it's a core strength that differentiates Cat machines from other brands. In fact, pump and other system components work to put more power to the ground, in a highly controlled, user-friendly way. This means you will move more material in less time and keep more money in your pocket at the end of the day.

Control Like No Other

The new Cat Adaptive Control System (ACS) valve optimizes performance by intelligently managing restrictions and flows to control machine motion, which means your operators will have the power and precision they need and expect. It opens slowly when your range of joystick lever movement is small and opens rapidly when movement is high. It smartly puts flow exactly where you need it when you need it, which leads to smoother operation, greater efficiency, and lower fuel consumption.

SmartBoom™

Reduces Stress and Vibrations Transmitted to the Machine

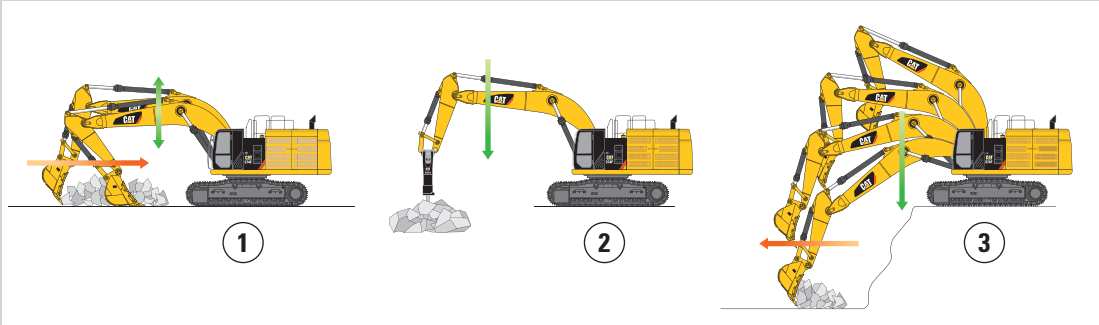

Rock Scraping (1)

Scraping rock and finishing work is easy and fast. SmartBoom simplifies the task and allows the operator to fully concentrate on the stick and bucket while the boom freely goes up and down without using pump flow.

Hammer Work (2)

It has never been this productive and operator-friendly. The front parts automatically follow the hammer while penetrating the rock. Blank shots or excessive force on the hammer are avoided, resulting in longer life for the hammer and machine. Similar advantages are applicable when using vibratory plates.

Truck Loading (3)

Loading trucks from a bench is more productive and fuel efficient as the return cycle is reduced while the boom down function does not require pump flow.

Auxiliary Hydraulics for Added Versatility

Auxiliary hydraulics give you greater tool versatility so you can take on more work with just one machine, and there are several options from which you can choose. A quick coupler circuit, for example, will allow you to switch from one tool to another in a matter of minutes.



Fuel Efficient

Engineered to lower your operating costs



The Cat C15 ACERT engine meets Stage IV emission standards and it does so without interrupting your job process. Simply turn the engine on and go to work. It will look for opportunities in your work cycle to regenerate itself, and it will give you plenty of power for the task at hand – all to help keep your owning and operating costs to an absolute minimum.

Fuel Savers That Add Up

The 374F L features two power modes to help manage fuel consumption: standard power and economy. Two additional fuel-saving features are on-demand engine power and engine idle shutdown. On-demand engine power keeps speed low during light loading and idling; it automatically adjusts speed up when it senses a heavier load. Engine idle shutdown automatically shuts the engine off when idling for more than a specified amount of time that you set, which can save significant amounts of fuel and reduce emissions.

Biodiesel Not A Problem

The C15 engine can run on biodiesel fuel up to B20 blended with ULSD. Just fill it up and go.

A Smart Design for Any Temperature

The 374F L features a new side-by-side cooling system that allows you to put the machine to work in extremely hot and cold conditions. The system is completely separated from the engine compartment to reduce noise and heat. Plus it features easy-to-clean cores and a new variable-speed fan that reverses to blow out unwanted debris that may accumulate during your work day.

Proven Technology

The right technologies fine-tuned for the right applications result in:

- **Improved Fluid Efficiency** – Up to 5% improvement over Stage IIIB products (including Diesel Exhaust Fluid consumption).
- **High Performance** across a variety of applications.
- **Enhanced Reliability** through commonality and simplicity of design.
- **Maximized Uptime and Reduced Cost** with world-class support Cat dealer support.
- **Minimized Impact of Emission Systems** – with no operator interaction required.
- **Durability** with long service life.
- **Better Fuel Economy** with minimized maintenance costs.
- **Same Great Power and Response.**

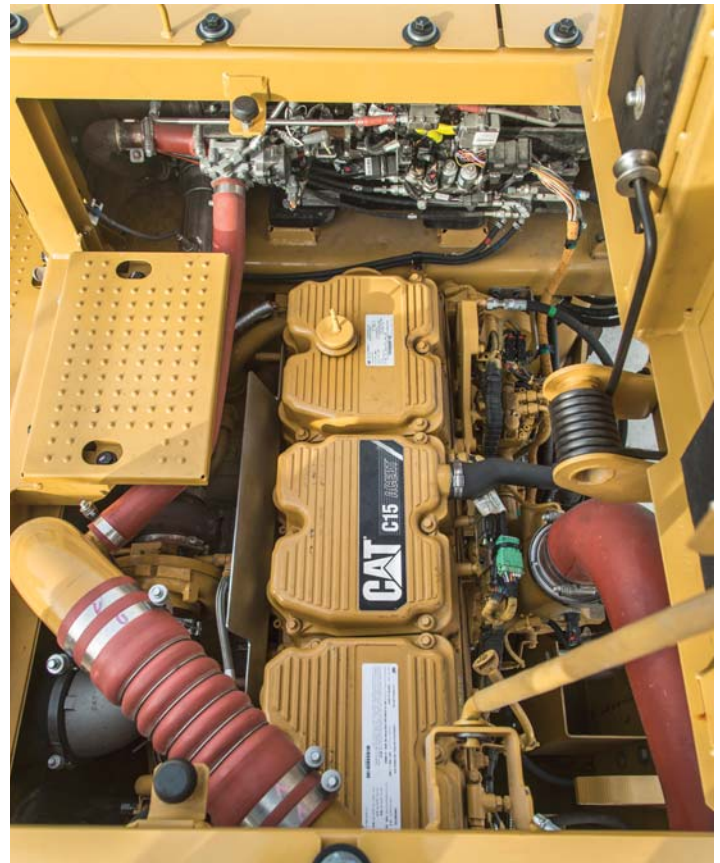

Easy to Operate

Comfort and convenience to keep you productive all day long



Safe and Quiet Cab

The cab contributes to your comfort thanks to special viscous mounts and special roof lining and sealing, that limit vibration and unnecessary sound.

Operators will enjoy the quietness and comfort of the all-new cab that's insulated to reduce sound inside by 4 dB over the previous model.

Excellent Ergonomics

Wide seats with air suspension and heat/cooling options, include a reclining back, upper and lower slide adjustments, and height and tilt angle adjustments to meet your needs for maximum comfort. The fully automatic climate control system keeps operators comfortable and productive all day long in either hot or cold weather. Storage spaces are located in the front, rear, and side consoles of the cab. A drink holder accommodates a large mug, and a shelf behind the seat stores large lunch or toolboxes. Power supply sockets are available for charging your electronic devices like an MP3 player, a cell phone, or even a tablet.

Controls Just for You

The right and left joystick consoles can be adjusted to improve your comfort and productivity during the course of a day. The right joystick features a button that will reduce engine speed when you are not working to help save fuel. Touch it once and speed reduces; touch it again and speed increases for normal operation.



Easy to Navigate Monitor

The new LCD monitor is easy to see and navigate. Not only can it memorize up to 10 different work tools, it's also programmable in up to 42 languages to meet today's diverse workforce. The monitor clearly displays critical information you need to operate efficiently and effectively. Plus it projects the image from the standard rearview camera to help you see what's going on around you so you can stay safely focused on the job at hand.

Durable Structures

Built to work in your tough, heavy-duty applications



Stable Undercarriage

Long variable gauge undercarriage contributes significantly to its outstanding stability and durability, and it adjusts to reduce shipping width.

Track shoes, links, rollers, idlers, and final drives are all built with high-tensile-strength steel for long-term durability.

Cat GLT4 track link protects moving parts by keeping water, debris, and dust out and grease sealed in, which delivers longer wear life and reduced noise when traveling.

Positive Pin Retention 2 (PPR2) prevents looseness of the track pin in the track link, reduces stress concentrations, and eliminates pin walking for increased service life.

Optional three-piece guide guards help maintain track alignment to improve your machine's overall performance – whether you're traveling on a flat, heavy bed of rock or a steep, wet field of mud.



Robust Frames

The 374F L is a robust, well-built machine designed to give you a very long service life. The upper frame has mountings made specifically to support the heavy-duty cab. It's also reinforced around areas that take on a lot of stress like the boom foot, skirt, and counterweight removal system.

Great Weight

The pressed fixed 10 300 kg or removable 11 000 kg counterweights are built with thick steel plates and reinforced fabrications to make them less susceptible to damage, and both have curved surfaces that match the machine's sleek, smooth appearance along with integrated housings to help protect the standard rearview camera.



Durable Linkages

Options to take on your far-reaching or up-close tasks

Built to Last

The 374F L is offered with a range of reach (R) and mass (ME) booms and sticks. Each is built with internal baffle plates and is stress relieved for added durability, and each undergoes ultrasound inspection to ensure quality and reliability. Large box-section structures with thick, multi-plate fabrications, castings, and forgings are used in high-stress areas such as the boom nose, boom foot, boom cylinder, and stick foot to improve durability. Also, the boom nose pin retention method is a captured flag design for enhanced durability.

Booms, Sticks and Bucket Linkage for Any Job

A 7.8 m reach boom (with 4.67 m or 4.15 m or 3.6 m or 2.84 m sticks) offer you excellent all-around versatility for general excavation work like multipurpose digging and loading. A 7.0 m mass boom (with 3.0 m or 2.57 m sticks) offer you enhanced performance in heavy-duty material like rock. They provide higher digging forces due to special boom and stick geometry, and bucket linkage and cylinders are built for greater durability.

Sticks are matched to the boom. Longer sticks are better for when you need to dig deep or load trucks.

Bucket linkages with or without a lifting eye are available.

Pins

All front linkage pins have thick chrome plating, giving them high wear resistance. Each pin diameter is made to distribute the shear and bending loads associated with the stick and to help ensure long pin, boom and stick life.

Talk to your Cat dealer to pick the best front linkage options for your applications.

Versatile

Do more jobs with one machine





Get the Most from One Machine

The Cat combination of machine and tool provides a total solution for just about any application. Work tools can be mounted either directly to the machine or to a quick coupler, making it fast and easy to release one work tool and pick up another.

Change Jobs Quickly

Cat quick coupler brings the ability to quickly change attachments and switch from job to job. The Cat Universal coupler is the secure way to decrease downtime and increase job site flexibility and overall productivity.

Available tool control remembers pressures and flows for up to 10 tools. Simply toggle through the monitor, select the tool, and go to work for maximum efficiency.

Dig, Rip and Load

A wide range of buckets dig everything from basic top soil to extreme, harsh material like ore and high quartzite granite. Rip through rock as an alternative to blasting in quarries. High-capacity buckets load trucks in a minimum number of passes for maximum productivity.

Break, Demolish and Scrap

A hydraulic hammer ably equips your machine for breaking rock in quarries. It will also make taking down bridge pillars and heavily reinforced concrete on road demolition jobs no problem.

Multi-processor and pulverizer attachments make your 374F L ideal for demolition jobs and processing the resulting debris. Shears with 360° rotation mount to the machine for processing scrap steel and metal.

Set Up Your Machine for Profitability

Your Cat dealer can install hydraulic kits to properly operate all Cat Work Tool attachments, maximizing the machine's uptime and your profit. All Cat Work Tool attachments are supported by the same Cat dealer network as your Cat machine.

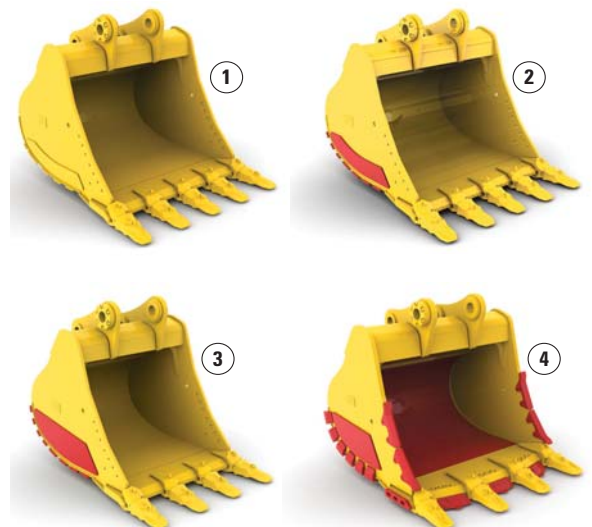

1) General Duty (GD) 2) Heavy Duty (HD)
3) Severe Duty (SD) 4) Extreme Duty (XD)



Integrated Technologies

Monitor, manage, and enhance job site operations

Cat Connect makes smart use of technology and services to improve your job site efficiency. Using the data from technology-equipped machines, you'll get more information and insight into your equipment and operations than ever before.

Cat Connect technologies offer improvements in these key areas:



Equipment Management – increase uptime and reduce operating costs.



Productivity – monitor production and manage job site efficiency.



Safety – enhance job site awareness to keep your people and equipment safe.

LINK Technologies

LINK technologies, like Product Link™, are deeply integrated into your machine and wirelessly communicates key information, including location, hours, fuel usage, idle time and event codes.

Product Link/VisionLink®

Easy access to Product Link data via the online VisionLink user interface can help you see how your machine or fleet is performing. You can use this information to make timely, fact based decisions that can boost job site efficiency and productivity, and lower costs.



GRADE Technologies

Grade technologies combine digital design data and in-cab guidance to help you reach target grade quickly and accurately, with minimal staking and checking. That means you'll be more productive, complete jobs faster, in fewer passes, using less fuel, at a lower cost.

Cat Grade Control Depth and Slope

The integrated Cat Grade Control system delivers 2D bucket tip elevation guidance to the cab to help operators create precise planes and slopes. Real-time bucket tip elevation guidance on the standard cab monitor indicates how much to cut or fill. Fast response sensors deliver immediate feedback, while optional integrated joystick buttons help operators make quick adjustments to maintain grade. Built-in alerts can be set to warn the operator if the linkage or bucket approaches a predefined elevation or depth, such as when working in areas with low ceilings, or digging near water lines. Staking and checking is minimized, which reduces ground crews and enhances job site safety.

Works best in simple 2D applications, such as digging trenches and basements or grading steep embankments.

Cat AccuGrade™

The dealer-installed AccuGrade system uses a dedicated monitor with a digital design plan for 3D bucket tip positioning and elevation guidance. AccuGrade indicates precisely where to work and how much to cut or fill – eliminating staking and checking.

Plug and play capability on the 374F L simplifies upgrading. Choose from satellite (GNSS) or total station (UTS) control for large projects with complex designs.



Safe Work Environment

Features to help protect you day in and day out



Great Views

Ample glass, coupled with the standard parallel wiper system, gives you excellent visibility out front and to the side.

Halogen lights provide plenty of illumination. Cab and boom lights can be programmed to stay on for up to 90 seconds after the engine has been turned off to help you safely exit the machine. Optional High Intensity Discharge (HID) lights are available for enhanced night-time visibility.

The standard rear vision camera greatly enhances visibility behind the machine to help the operator work more productively. A panoramic rearview is automatically displayed on the new multi-function monitor during reverse travel. As an option, a second display can be added, providing a dedicated full-time rearview of the job site.



Secure Contact Points

Multiple large steps as well as hand and guard rails will get you into the cab as well as a leg up to the catwalks and compartments. Extended hand and guard rails allow you to safely climb to the upper deck. Anti-skid plates on the catwalks, the surface of the upper structure, and the top of the storage box area reduce your slipping hazards in all types of weather conditions. They can be removed for cleaning.

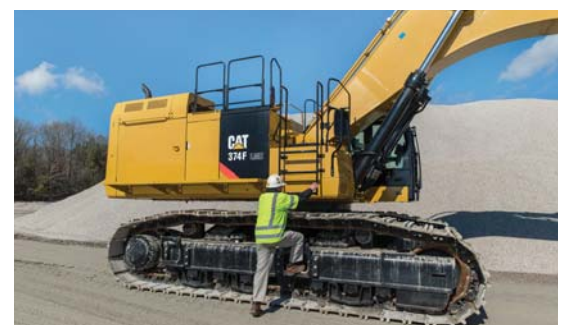

Serviceable

Designed to make your maintenance quick and easy



Convenient Access Built In

You can reach routine maintenance items like greasing points and a concentrated remote greasing block on boom foot from ground level.

Compartments feature wide service doors designed to help prevent debris entry, and they also securely latch in place to help make your service work simpler. Machine's slip-resistant 500 mm wide catwalks stretch the length of the 374F L to provide safe access to major and grouped service points, such as fuel and oil filters, and fluid taps.



Quick and Convenient Fluids Service

Oil sample and pressure ports provide easy checking of machine condition and are standard on every machine.

You can ensure fast, easy, and secure changing of engine and hydraulic oil with the QuickEvac™ option.

The fuel tank's drain cock makes it easy and simple for you to remove water and sediment during routine maintenance. Plus an integrated fuel level indicator pops up to help you reduce the possibility of fuel tank overfilling. An optional fast fill port accessible from ground level can make refueling even easier and faster.

A Smart Cooling Design

The 374F L features a new side-by-side cooling system with easy-to-clean cores and a new variable-speed fan that reverses to blow out unwanted debris that may accumulate during your work day.

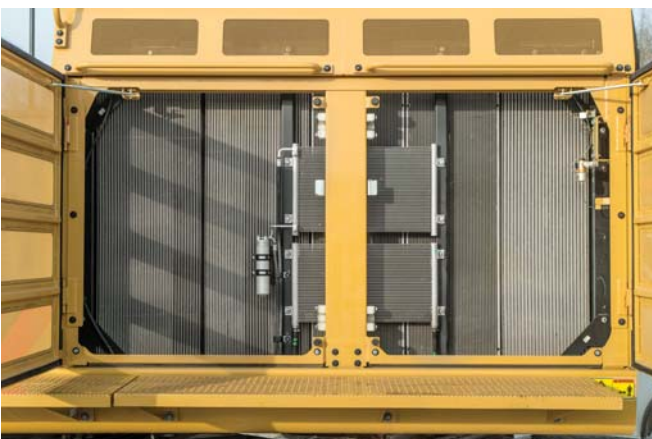

A Fresh Idea

Selecting ventilation inside the cab allows outside air to enter through a fresh air filter. The filter is conveniently located on the side of the cab to make it easy to reach and replace, and it is protected by a lockable door that can be opened with the engine key.



Complete Customer Care

Unmatched support makes the difference

Sustainable Generations ahead in every way

The 374F L is designed to compliment your business plan, reduce emissions and minimize the consumption of natural resources.

- The C15 ACERT engine meets Stage IV emission standards.
- The 374F L has the flexibility of running on either ultra-low-sulfur diesel (ULSD) fuel with 10 ppm of sulfur or less or up to bio diesel (B20) fuel blended with ULSD.
- An overfill indicator rises when the tank is full to help the operator avoid spilling.
- Quick fill ports with connectors ensure fast, easy, and secure changing of hydraulic oil.
- Major components are rebuildable, eliminating waste and saving money by giving the machine and/or major components a second life – and even a third life.
- Link technologies enable you to collect and analyze equipment and job site data so you can maximize productivity and reduce costs.
- The 374F L is an efficient, productive machine that's designed to conserve our natural resources for generations ahead.

Worldwide Parts Availability

Cat dealers utilize a worldwide parts network to maximize your machines' uptime. Plus they can help you save money with Cat remanufactured components.

Financial Options Just for You

Consider financing options and day-to-day operating costs. Look at dealer services that can be included in the machine's cost to yield lower owning and operating costs over time.

What's Best for You Today...and Tomorrow

Repair, rebuild, or replace? Your Cat dealer can help you evaluate the cost involved so you can make the best choice for your business.

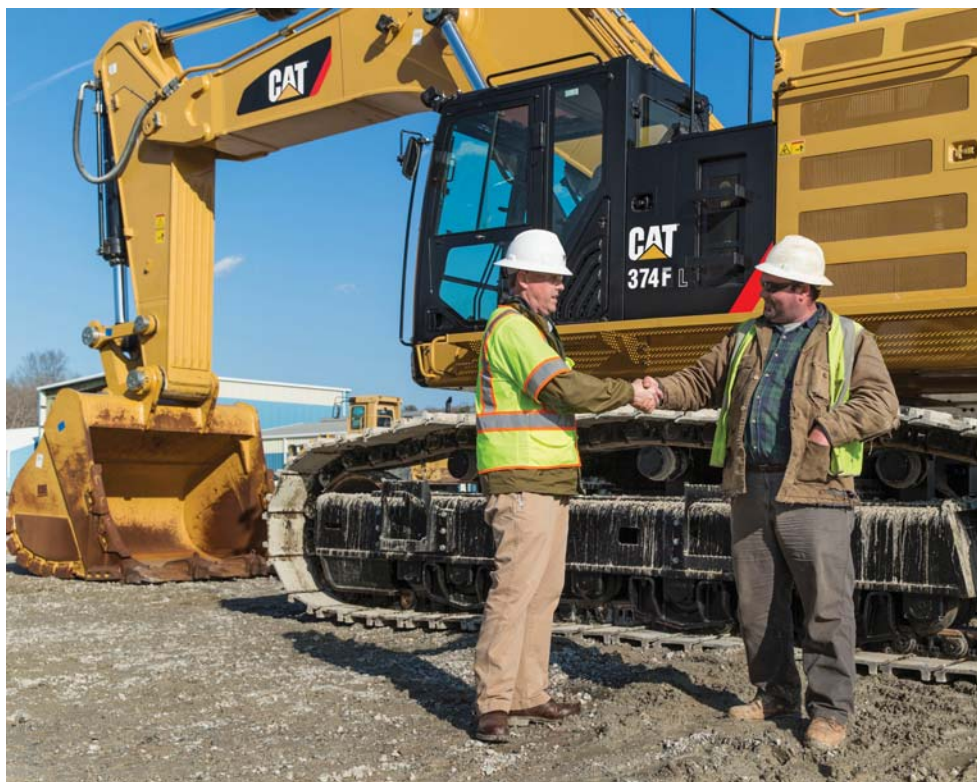

374F L Hydraulic Excavator Specifications

Engine

Engine Model	Cat C15 ACERT
Power – SAE J1995 (metric)	367 kW (499 hp)
Power – ISO 14396 (metric)	362 kW (492 hp)
Power – ISO 9249 (metric)	352 kW (479 hp)
Bore	137 mm
Stroke	171 mm
Displacement	15.2 L

- The 374F L meets Stage IV emission standards.
- No engine power derating required below 2300 m altitude.
- Rating at 1,600 rpm (Implement).

Operating Weights

Minimum – Reach Configuration	70 970 kg
Maximum – Mass Configuration	75 170 kg

Drive

Gradeability	30°/70%
Maximum Travel Speed	4.1 km/h
Maximum Drawbar Pull	492 kN

Track

Track Options	900 mm 750 mm 650 mm
Number of Shoes Each Side	47
Number of Track Rollers Each Side	8
Number of Carrier Rollers Each Side	3

Swing Mechanism

Swing Speed	6.5 rpm
Swing Torque	215 kN·m

Service Refill Capacities

Fuel Tank Capacity	935 L
Cooling System	74 L
Engine Oil	60 L
Swing Drive (each)	12 L
Final Drive (each)	22 L
Hydraulic System Oil Capacity (including tank)	729 L
Hydraulic Tank Oil	612 L
DEF Tank	48 L

Hydraulic System

Main System – Maximum Flow (total)	
Implement	896 L/min
Travel	952 L/min
Swing System – Maximum Flow	
No swing pump	
Maximum Pressure	
Equipment	37 000 kPa
Travel	35 000 kPa
Swing	29 400 kPa
Pilot System	
Maximum Flow	63 L/min
Maximum Pressure	4.0-4.4 MPa
Boom Cylinder	
Bore	190 mm
Stroke	1792 mm
Stick Cylinder	
Bore	210 mm
Stroke	2118 mm
VB2 – Family Bucket Cylinder	
Bore	190 mm
Stroke	1433 mm
WB2 – Family Bucket Cylinder	
Bore	200 mm
Stroke	1457 mm

Sound Performance

Operator Sound Pressure Level ISO 6396:2008	72 dB(A)
Exterior Sound Power Level ISO 6395:2008	108 dB(A)*

- Hearing protection may be needed when operating with an open operator station and cab (when not properly maintained or doors/windows open) for extended periods or in a noisy environment.
 - When properly installed and maintained, the cab offered by Caterpillar, when tested with doors and windows closed according to ANSI/SAE J1166 OCT98, meets OSHA and MSHA requirements for operator sound exposure limits in effect at time of manufacture.
- *as per European Union Directive 2000/14/EC as amended by 2005/88/EC

Standards

Brakes	SAE J1026/APR90
Cab/FOGS	SAE J1356 FEB88 ISO 10262
DEF	ISO 22241

374F L Hydraulic Excavator Specifications

Dimensions

All dimensions are approximate.

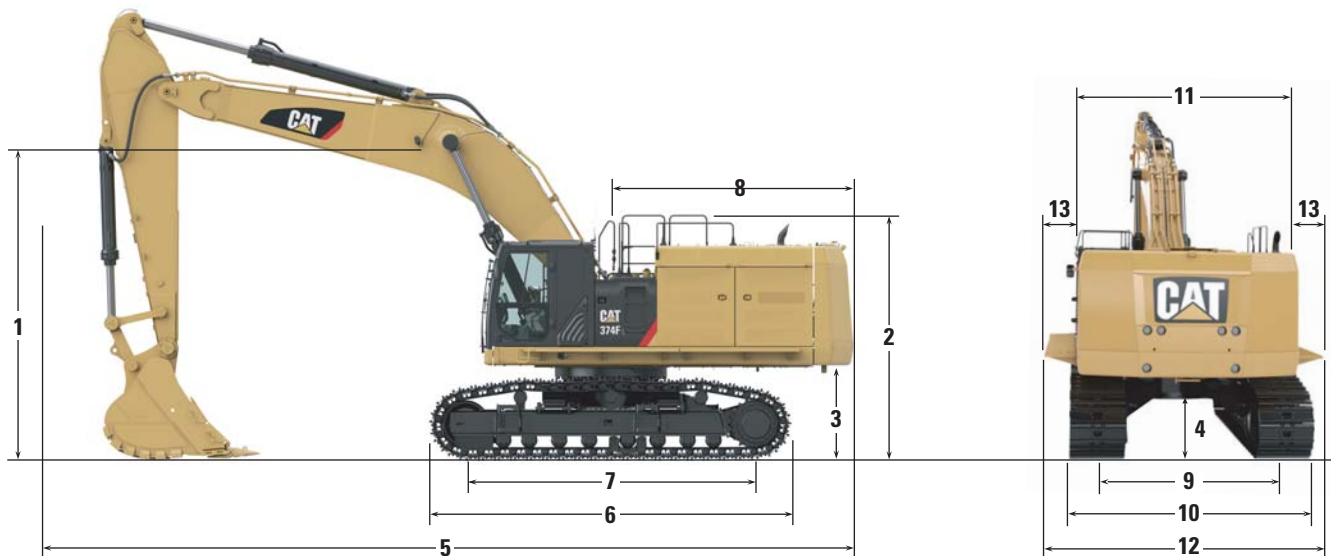

Boom Options

Reach Boom 7.8 m

Mass Boom 7.0 m

Stick Options	R4.67 m	R4.15 m	R3.60 m	R2.84 m	M3.00 m	M2.57 m
1 Height – with boom/stick installed	4990 mm	4650 mm	4520 mm	4300 mm	4720 mm	4630 mm
2 Guardrail Height	3970 mm	3970 mm	3970 mm	3970 mm	3970 mm	3970 mm
3 Counterweight Clearance	1540 mm	1540 mm	1540 mm	1540 mm	1540 mm	1540 mm
4 Ground Clearance	840 mm	840 mm	840 mm	840 mm	840 mm	840 mm
5 Length – with boom/stick installed	13 230 mm	13 310 mm	13 330 mm	13 430 mm	12 620 mm	12 660 mm
6 Track Length	5870 mm	5870 mm	5870 mm	5870 mm	5870 mm	5870 mm
7 Length to Center of Rollers	4705 mm	4705 mm	4705 mm	4705 mm	4705 mm	4705 mm
8 Tail Swing Radius	4015 mm	4015 mm	4015 mm	4015 mm	4015 mm	4015 mm
9 Track Gauge – retracted	2750 mm	2750 mm	2750 mm	2750 mm	2750 mm	2750 mm
Track Gauge – extended	3410 mm	3410 mm	3410 mm	3410 mm	3410 mm	3410 mm
10 Undercarriage Width – without steps						
650 mm Shoes	4060 mm	4060 mm	4060 mm	4060 mm	4060 mm	4060 mm
750 mm Shoes	4160 mm	4160 mm	4160 mm	4160 mm	4160 mm	4160 mm
900 mm Shoes	4310 mm	4310 mm	4310 mm	4310 mm	4310 mm	4310 mm
Undercarriage Width – including steps						
650 mm Shoes	4340 mm	4340 mm	4340 mm	4340 mm	4340 mm	4340 mm
750 mm Shoes	4340 mm	4340 mm	4340 mm	4340 mm	4340 mm	4340 mm
900 mm Shoes	4340 mm	4340 mm	4340 mm	4340 mm	4340 mm	4340 mm
11 Upperframe Width – without walkways	3450 mm	3450 mm	3450 mm	3450 mm	3450 mm	3450 mm
12 Upperframe Width – with walkways	4510 mm	4510 mm	4510 mm	4510 mm	4510 mm	4510 mm
13 Walkway Width (each)	530 mm	530 mm	530 mm	530 mm	530 mm	530 mm
Bucket Type	GD	GD	GD	GD	SDV	SDV
Bucket Capacity	3.8 m ³	3.8 m ³	3.8 m ³	3.8 m ³	4.6 m ³	4.6 m ³
Bucket Tip Radius	1900 mm	1900 mm	1900 mm	1900 mm	2000 mm	2000 mm

Dimensions may vary depending on bucket selection.

374F L Hydraulic Excavator Specifications

Working Ranges

All dimensions are approximate.

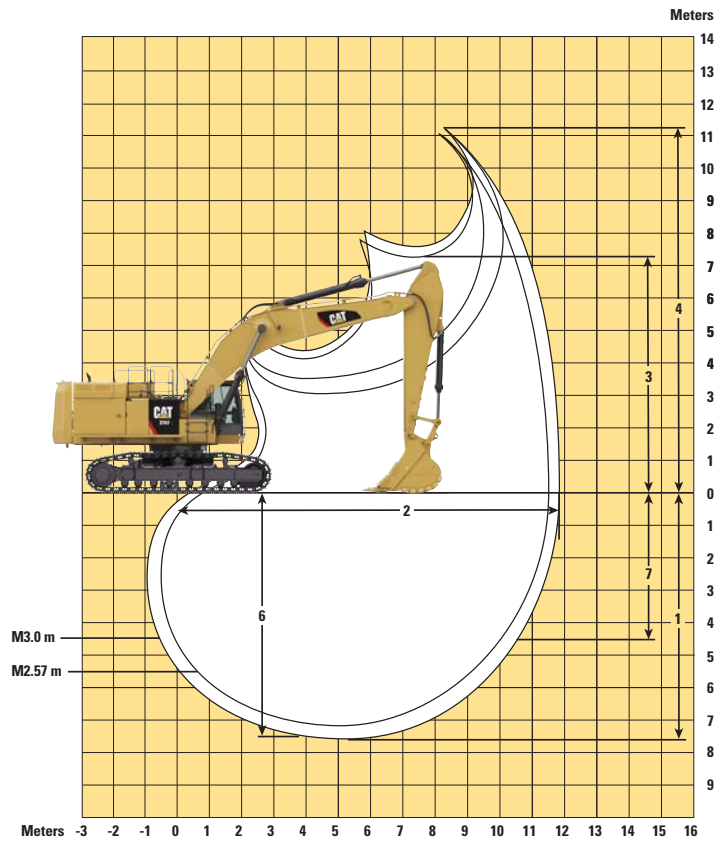
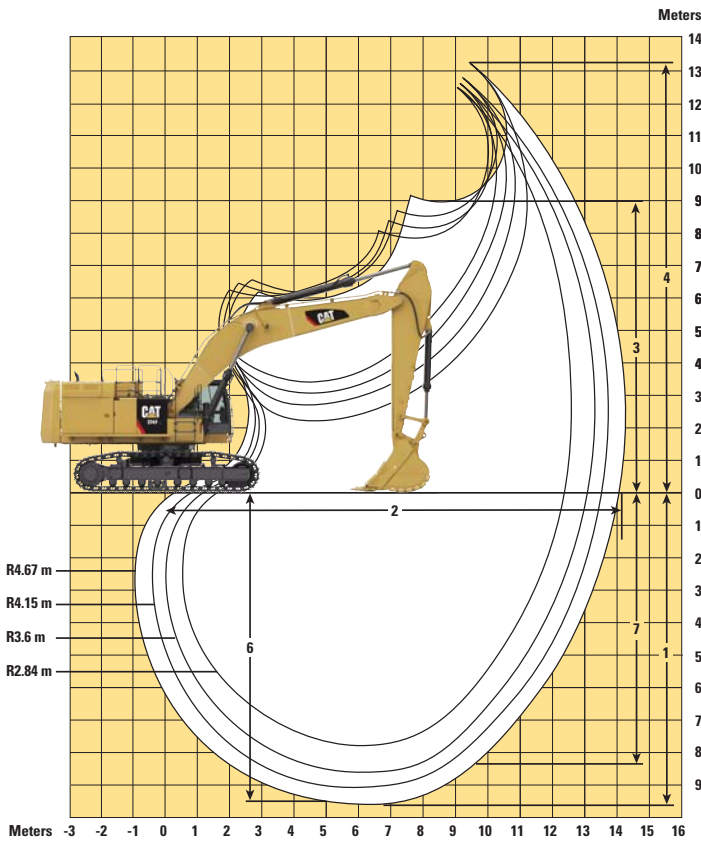

Boom Options

Reach Boom 7.8 m

Mass Boom 7.0 m

Stick Options	R4.67 m	R4.15 m	R3.6 m	R2.84 m	M3.0 m	M2.57 m
1 Maximum Digging Depth	9650 mm	9130 mm	8580 mm	7820 mm	7640 mm	7220 mm
2 Maximum Reach at Ground Line	14 230 mm	13 690 mm	13 170 mm	12 530 mm	11 850 mm	11 450 mm
3 Maximum Loading Height	9000 mm	8640 mm	8410 mm	8250 mm	7240 mm	7080 mm
4 Maximum Cutting Height	13 210 mm	12 820 mm	12 560 mm	12 450 mm	11 180 mm	11 010 mm
5 Minimum Loading Height	2230 mm	2750 mm	3300 mm	4060 mm	3070 mm	3490 mm
6 Maximum Depth Cut for 2240 mm Level Bottom	9550 mm	9020 mm	8460 mm	7680 mm	7500 mm	7060 mm
7 Maximum Vertical Wall Digging Depth	8530 mm	7840 mm	7140 mm	6660 mm	4510 mm	4140 mm
Bucket Digging Force (ISO)	359.1 kN	359.1 kN	358.3 kN	356.4 kN	411.8 kN	411.3 kN
Stick Digging Force (ISO)	247.5 kN	268.4 kN	295.3 kN	330.0 kN	323.2 kN	353.1 kN
Bucket Type	GD	GD	GD	GD	SDV	SDV
Bucket Capacity	3.8 m ³	3.8 m ³	3.8 m ³	3.8 m ³	4.6 m ³	4.6 m ³
Bucket Tip Radius	1900 mm	1900 mm	1900 mm	1900 mm	2000 mm	2000 mm

Dimensions may vary depending on bucket selection.

374F L Hydraulic Excavator Specifications

Operating Weights and Ground Pressures

Boom	Stick	Bucket	900 mm Shoes		750 mm Shoes		650 mm Shoes	
			Weight	Ground Pressure	Weight	Ground Pressure	Weight	Ground Pressure
R7.8 m	R4.67 m	3.8 m ³	73 199 kg	78.0 kPa	72 186 kg	92.3 kPa	71 511 kg	105.5 kPa
R7.8 m	R4.15 m	3.8 m ³	72 990 kg	77.8 kPa	71 977 kg	92.0 kPa	71 302 kg	105.2 kPa
R7.8 m	R3.60 m	3.8 m ³	72 848 kg	77.6 kPa	71 835 kg	91.8 kPa	71 160 kg	105.0 kPa
R7.8 m	R2.84 m	3.8 m ³	72 661 kg	77.4 kPa	71 648 kg	91.6 kPa	70 973 kg	104.7 kPa
M7.0 m	M3.0 m	4.6 m ³	75 167 kg	80.1 kPa	74 154 kg	94.8 kPa	73 479 kg	108.4 kPa
M7.0 m	M2.57 m	4.6 m ³	74 958 kg	79.9 kPa	73 945 kg	94.5 kPa	73 270 kg	108.1 kPa

Major Components Weights

	kg
Base Machine (with counterweight, without front linkage, without bucket)*	
650 mm Tracks	55 435
750 mm Tracks	56 110
900 mm Tracks	57 123
Two Boom Cylinders	1375
Counterweight	
Removal Type	10 300
Non-removal Type	11 000
Boom (includes lines, pins, stick cylinder)	
Reach Boom – 7.8 m	6720
Mass Boom – 7.0 m	7040
Stick (includes lines, pins, bucket cylinder, linkage)	
R4.67 m	4025
R4.15 m	3815
R3.60 m	3675
R2.84 m	3490
M3.0 m	4230
M2.6 m	4020
Bucket	
3.8 m ³ GD	3670
4.6 m ³ SDV	4050

*Base machine includes 75 kg operator weight and 90% fuel weight, and undercarriage with center guard.

374F L Hydraulic Excavator Specifications

Reach Boom Lift Capacities – Counterweight: 11 mt – without Bucket

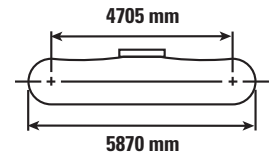
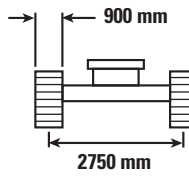
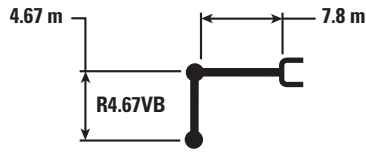

Reach Boom	Unit	1.5 m		3.0 m		4.5 m		6.0 m		7.5 m		9.0 m		10.5 m		12.0 m		mm		
		ISO 10567	ISO 10567	ISO 10567	ISO 10567	ISO 10567	ISO 10567	ISO 10567	ISO 10567	ISO 10567	ISO 10567	ISO 10567	ISO 10567	ISO 10567	ISO 10567	ISO 10567	ISO 10567	ISO 10567	ISO 10567	ISO 10567
10.5 m	kg											*12 450	*12 450					*11 500	*11 500	9200
9.0 m	kg											*13 350	*13 350					*10 850	*10 850	10 330
7.5 m	kg											*13 650	*13 650	*13 150	11 800			*10 550	*10 550	11 140
6.0 m	kg											*14 450	*14 450	*13 450	11 600			*10 500	9550	11 700
4.5 m	kg					*28 300	*28 300	*21 350	*21 350	*17 700	*17 700	*15 500	14 450	*14 000	11 300	*11 050	9000	*10 650	8950	12 050
3.0 m	kg							*24 700	*24 700	*19 600	18 200	*16 600	13 850	*14 650	10 950	12 200	8850	*11 000	8600	12 200
1.5 m	kg							*27 200	23 950	*21 200	17 300	*17 600	13 300	14 700	10 600	12 000	8650	*11 600	8500	12 160
0.0 m	kg					*18 350	*18 350	*28 450	23 050	*22 200	16 700	18 050	12 900	14 400	10 350			12 000	8600	11 930
-1.5 m	kg			*13 300	*13 300	*24 100	*24 100	*28 400	22 600	*22 350	16 300	17 800	12 650	14 250	10 200			12 550	9000	11 510
-3.0 m	kg	*16 300	*16 300	*20 900	*20 900	*32 600	*32 600	*27 150	22 500	*21 600	16 200	*17 650	12 550	14 250	10 200			*13 450	9800	10 850
-4.5 m	kg			*30 100	*30 100	*31 250	*31 250	*24 600	22 700	*19 750	16 300	*15 800	12 700					*13 250	11 200	9920
-6.0 m	kg			*32 000	*32 000	*25 300	*25 300	*20 300	*20 300	*16 000	*16 000							*12 500	*12 500	8640



ISO 10567



*Indicates that the load is limited by hydraulic lifting capacity rather than tipping load. The above loads are in compliance with hydraulic excavator lift capacity standard ISO 10567:2007. They do not exceed 87% of hydraulic lifting capacity or 75% of tipping load. Weight of all lifting accessories must be deducted from the above lifting capacities. Lifting capacities are based on the machine standing on a firm, uniform supporting surface. The use of a work tool attachment point to handle/lift objects, could affect the machine lift performance.

Lift capacity stays with ±5% for all available track shoes.

Always refer to the appropriate Operation and Maintenance Manual for specific product information.

374F L Hydraulic Excavator Specifications

Reach Boom Lift Capacities – Counterweight: 11 mt – without Bucket

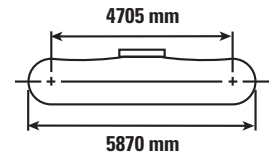
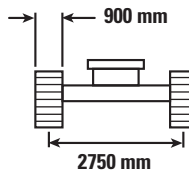
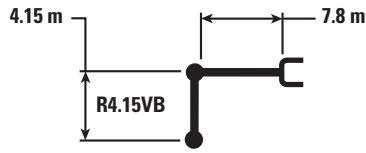

Reach (m)	Unit	3.0 m		4.5 m		6.0 m		7.5 m		9.0 m		10.5 m		mm		
		ISO 10567	ISO 10567	ISO 10567	ISO 10567	ISO 10567	ISO 10567	ISO 10567	ISO 10567	ISO 10567	ISO 10567	ISO 10567	ISO 10567	ISO 10567	ISO 10567	ISO 10567
10.5 m	kg													*13 250	*13 250	8470
9.0 m	kg									*14 300	*14 300			*12 450	*12 450	9690
7.5 m	kg									*14 500	*14 500	*12 550	11 650	*12 150	11 550	10 550
6.0 m	kg							*16 900	*16 900	*15 200	14 850	*14 150	11 500	*12 150	10 400	11 140
4.5 m	kg					*22 800	*22 800	*18 650	*18 650	*16 200	14 350	*14 600	11 250	*12 350	9650	11 500
3.0 m	kg					*25 900	25 000	*20 450	18 000	*17 200	13 800	15 000	10 950	12 750	9300	11 660
1.5 m	kg					*28 000	23 750	*21 800	17 250	*18 050	13 300	14 700	10 650	12 650	9150	11 620
0.0 m	kg			*17 900	*17 900	*28 800	23 000	*22 550	16 700	18 100	12 950	14 500	10 450	12 900	9350	11 380
-1.5 m	kg	*14 200	*14 200	*25 500	*25 500	*28 250	22 750	*22 400	16 450	17 900	12 750	14 400	10 350	13 600	9800	10 930
-3.0 m	kg	*23 400	*23 400	*33 800	*33 800	*26 550	22 750	*21 300	16 400	*17 300	12 750			*14 250	10 750	10 240
-4.5 m	kg	*34 400	*34 400	*29 300	*29 300	*23 500	23 050	*18 900	16 600	*14 750	12 950			*13 950	12 550	9250
-6.0 m	kg			*22 550	*22 550	*18 350	*18 350	*14 050	*14 050					*12 850	*12 850	7860



ISO 10567



*Indicates that the load is limited by hydraulic lifting capacity rather than tipping load. The above loads are in compliance with hydraulic excavator lift capacity standard ISO 10567:2007. They do not exceed 87% of hydraulic lifting capacity or 75% of tipping load. Weight of all lifting accessories must be deducted from the above lifting capacities. Lifting capacities are based on the machine standing on a firm, uniform supporting surface. The use of a work tool attachment point to handle/lift objects, could affect the machine lift performance.

Lift capacity stays with ±5% for all available track shoes.

Always refer to the appropriate Operation and Maintenance Manual for specific product information.

374F L Hydraulic Excavator Specifications

Reach Boom Lift Capacities – Counterweight: 11 mt – without Bucket

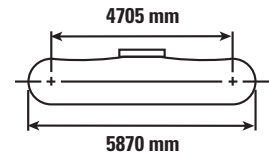
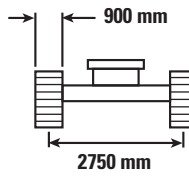
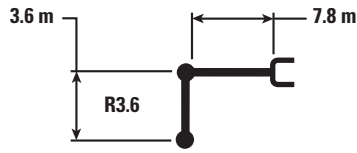

	3.0 m		4.5 m		6.0 m		7.5 m		9.0 m		10.5 m		mm		
10.5 m kg													*15 750	*15 750	7760
9.0 m kg									*15 300	15 100			*14 750	*14 750	9070
7.5 m kg							*16 500	*16 500	*15 350	15 000			*14 300	12 550	9980
6.0 m kg					*20 950	*20 950	*17 850	*17 850	*15 950	14 650	*14 800	11 350	*14 300	11 150	10 610
4.5 m kg					*24 150	*24 150	*19 500	18 700	*16 850	14 200	*15 150	11 150	14 150	10 350	10 990
3.0 m kg					*27 000	24 550	*21 150	17 800	*17 750	13 700	14 950	10 900	13 650	9900	11 150
1.5 m kg					*28 650	23 500	*22 300	17 150	*18 450	13 250	14 700	10 650	13 550	9800	11 110
0.0 m kg					*28 850	23 000	*22 750	16 700	18 100	12 950	14 550	10 500	13 850	10 000	10 860
-1.5 m kg			*26 100	*26 100	*27 850	22 850	*22 250	16 500	17 950	12 850			14 750	10 600	10 390
-3.0 m kg	*25 650	*25 650	*31 800	*31 800	*25 650	22 950	*20 750	16 550	*16 700	12 900			*14 850	11 800	9660
-4.5 m kg	*31 600	*31 600	*26 750	*26 750	*22 000	*22 000	*17 650	16 850					*14 250	14 050	8600
-6.0 m kg					*15 700	*15 700							*12 450	*12 450	7070



ISO 10567



*Indicates that the load is limited by hydraulic lifting capacity rather than tipping load. The above loads are in compliance with hydraulic excavator lift capacity standard ISO 10567:2007. They do not exceed 87% of hydraulic lifting capacity or 75% of tipping load. Weight of all lifting accessories must be deducted from the above lifting capacities. Lifting capacities are based on the machine standing on a firm, uniform supporting surface. The use of a work tool attachment point to handle/lift objects, could affect the machine lift performance.

Lift capacity stays with ±5% for all available track shoes.

Always refer to the appropriate Operation and Maintenance Manual for specific product information.

374F L Hydraulic Excavator Specifications

Reach Boom Lift Capacities – Counterweight: 11 mt – without Bucket

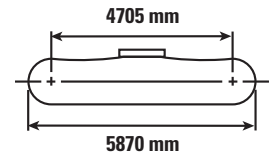
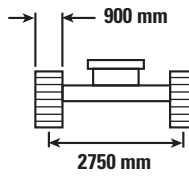
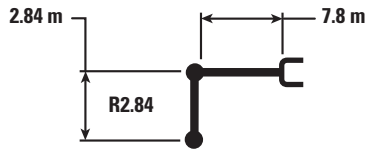

Reach (m)	Unit	4.5 m		6.0 m		7.5 m		9.0 m		10.5 m		mm		
10.5 m	kg											*18 700	*18 700	6820
9.0 m	kg					*17 450	*17 450					*17 200	17 000	8280
7.5 m	kg					*17 850	*17 850	*16 600	14 750			*16 500	13 950	9280
6.0 m	kg	*30 350	*30 350	*22 800	*22 800	*19 050	*19 050	*16 950	14 450			*16 150	12 300	9950
4.5 m	kg			*25 850	25 400	*20 600	18 350	*17 650	14 050			15 500	11 300	10 350
3.0 m	kg			*28 250	24 000	*21 950	17 550	*18 350	13 600	14 900	10 850	14 850	10 800	10 530
1.5 m	kg			*29 050	23 250	*22 750	17 000	18 400	13 250			14 800	10 750	10 490
0.0 m	kg			*28 450	23 000	*22 750	16 700	18 150	13 000			15 250	11 000	10 220
-1.5 m	kg	*24 800	*24 800	*26 800	23 000	*21 800	16 600	*17 750	13 000			*15 800	11 800	9710
-3.0 m	kg	*28 300	*28 300	*23 950	23 250	*19 600	16 800					*15 300	13 400	8930
-4.5 m	kg	*22 600	*22 600	*19 350	*19 350	*15 050	*15 050					*14 000	*14 000	7770



ISO 10567



*Indicates that the load is limited by hydraulic lifting capacity rather than tipping load. The above loads are in compliance with hydraulic excavator lift capacity standard ISO 10567:2007. They do not exceed 87% of hydraulic lifting capacity or 75% of tipping load. Weight of all lifting accessories must be deducted from the above lifting capacities. Lifting capacities are based on the machine standing on a firm, uniform supporting surface. The use of a work tool attachment point to handle/lift objects, could affect the machine lift performance.

Lift capacity stays with ±5% for all available track shoes.

Always refer to the appropriate Operation and Maintenance Manual for specific product information.

374F L Hydraulic Excavator Specifications

Mass Boom Lift Capacities – Counterweight: 11 mt – without Bucket

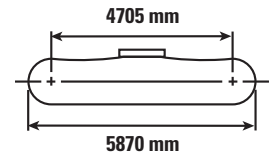
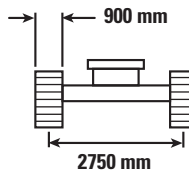

		3.0 m		4.5 m		6.0 m		7.5 m		9.0 m		mm		
9.0 m	kg											*14 750	*14 750	7350
7.5 m	kg							*17 400	*17 400			*13 950	*13 950	8460
6.0 m	kg					*20 950	*20 950	*18 250	*18 250	*16 850	14 250	*13 750	13 750	9190
4.5 m	kg			*32 500	*32 500	*23 850	*23 850	*19 700	18 550	*17 350	13 900	*14 000	12 450	9630
3.0 m	kg					*26 650	24 650	*21 150	17 750	*18 000	13 500	*14 600	11 800	9820
1.5 m	kg					*28 400	23 600	*22 250	17 050	18 350	13 150	*15 750	11 650	9770
0.0 m	kg			*30 800	*30 800	*28 650	23 000	*22 550	16 650	18 100	12 900	16 800	12 050	9480
-1.5 m	kg	*25 350	*25 350	*35 350	*35 350	*27 500	22 900	*21 750	16 500			*17 300	13 050	8930
-3.0 m	kg	*38 200	*38 200	*31 100	*31 100	*24 650	23 100	*19 200	16 700			*17 050	15 200	8070
-4.5 m	kg			*24 150	*24 150	*18 950	*18 950					*15 800	*15 800	6760



ISO 10567



*Indicates that the load is limited by hydraulic lifting capacity rather than tipping load. The above loads are in compliance with hydraulic excavator lift capacity standard ISO 10567:2007. They do not exceed 87% of hydraulic lifting capacity or 75% of tipping load. Weight of all lifting accessories must be deducted from the above lifting capacities. Lifting capacities are based on the machine standing on a firm, uniform supporting surface. The use of a work tool attachment point to handle/lift objects, could affect the machine lift performance.

Lift capacity stays with $\pm 5\%$ for all available track shoes.

Always refer to the appropriate Operation and Maintenance Manual for specific product information.

374F L Hydraulic Excavator Specifications

Mass Boom Lift Capacities – Counterweight: 11 mt – without Bucket

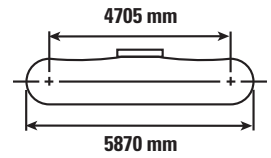
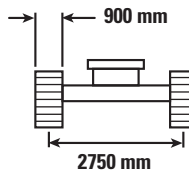
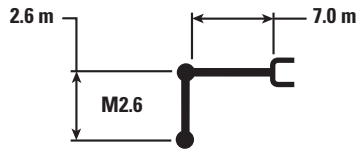

Reach (m)	Unit	3.0 m		4.5 m		6.0 m		7.5 m		9.0 m		mm		
		Hydraulic	Tipping	Hydraulic	Tipping	Hydraulic	Tipping	Hydraulic	Tipping	Hydraulic	Tipping	Hydraulic	Tipping	
9.0 m	kg											*17 650	*17 650	6820
7.5 m	kg							*18 450	*18 450			*16 650	*16 650	8010
6.0 m	kg					*22 050	*22 050	*19 100	*19 100			*16 400	14 800	8770
4.5 m	kg					*24 900	*24 900	*20 400	18 450	*18 000	13 900	*16 700	13 300	9230
3.0 m	kg					*27 500	24 500	*21 750	17 700	*18 500	13 500	17 450	12 600	9430
1.5 m	kg					*28 850	23 550	*22 600	17 100	18 400	13 200	17 350	12 450	9380
0.0 m	kg			*28 500	*28 500	*28 650	23 150	*22 650	16 750	18 250	13 050	18 050	12 900	9080
-1.5 m	kg			*33 950	*33 950	*27 050	23 100	*21 450	16 700			*18 050	14 150	8510
-3.0 m	kg	*33 600	*33 600	*29 250	*29 250	*23 600	23 450	*18 000	17 050			*17 600	16 800	7590
-4.5 m	kg			*21 400	*21 400	*16 450	*16 450					*15 600	*15 600	6180



ISO 10567



*Indicates that the load is limited by hydraulic lifting capacity rather than tipping load. The above loads are in compliance with hydraulic excavator lift capacity standard ISO 10567:2007. They do not exceed 87% of hydraulic lifting capacity or 75% of tipping load. Weight of all lifting accessories must be deducted from the above lifting capacities. Lifting capacities are based on the machine standing on a firm, uniform supporting surface. The use of a work tool attachment point to handle/lift objects, could affect the machine lift performance.

Lift capacity stays with ±5% for all available track shoes.

Always refer to the appropriate Operation and Maintenance Manual for specific product information.

374F L Hydraulic Excavator Specifications

Bucket Specifications and Compatibility

	Linkage	Width	Capacity	Weight	Fill Factor	Reach Boom			Mass Boom	
						2.84 m	3.60 m	4.67 m	2.57 m	3.00 m
						650 mm DG (Standard)			650 mm DG (Standard)	
Without Quick Coupler										
General Duty (GD)	VB2	1525	2.90	3205	100	●	●	⊙		
	VB2	1900	3.80	3622	100	⊙	⊖	○		
	VB2	1900	3.80	3720	100	⊙	⊖	○		
	WB2	2000	4.60	4016	100				●	⊙
	WB2	2100	5.00	4167	100				⊙	⊖
General Duty XL (GDXL)	VB2	2000	4.60	4077	100	⊖	○	◇		
Heavy Duty (HD)	VB2	1220	2.20	2892	100	●	●	●		
	VB2	1700	3.30	3529	100	●	⊙	⊖		
	VB2	1900	3.80	3881	100	⊙	⊖	○		
	VB2	1900	3.80	3782	100	⊙	⊖	○		
	WB2	2100	5.00	4345	100				⊙	⊖
Severe Duty (SD)	WB2	2250	5.30	4591	100				⊖	⊖
	VB2	1100	1.90	2840	90	●	●	●		
	VB2	1525	2.90	3453	90	●	●	⊙		
	VB2	1700	3.30	3653	90	●	●	⊖		
	VB2	1900	3.80	4016	90	●	⊙	○		
	WB2	1800	3.70	4667	90				●	●
	WB2	1900	4.00	4825	90				●	●
	WB2	2000	4.40	4982	90				●	⊙
	WB2	2100	4.60	5141	90				●	⊙
	WB2	2200	4.60	5227	90				●	⊙
Extreme Duty (XD)	WB2	2200	5.00	5341	90				⊙	⊖
	VB2	1900	3.80	4806	90	⊙	⊖	◇		
	WB2	1900	4.00	5587	90				●	⊙
	WB2	2000	4.40	5785	90				⊙	⊙
	WB2	2100	4.40	5866	90				⊙	⊖
	WB2	2150	4.60	5982	90				⊙	⊖
Extreme Duty Granite (XDG)	WB2	2200	5.00	6171	90				⊖	○
	WB2	2000	4.37	5992	90				⊙	⊖
									⊙	⊖
Maximum load pin-on (payload + bucket)					kg	11 041	9978	8374	13 595	12 557
With Quick Coupler (CW-70)										
General Duty (GD)	VB2	1900	3.80	3668	100	⊖	○	⊗		
Severe Duty (SD)	WB2	1900	4.00	4802	90				⊙	⊖
	WB2	2000	4.40	4959	90				⊙	⊖
Extreme Duty (XD)	WB2	2000	4.40	5797	90				⊖	○
Maximum load pin-on (payload + bucket)					kg	9721	8658	7054	12 275	11 237

The above loads are in compliance with hydraulic excavator standard EN474, they do not exceed 87% of hydraulic lifting capacity or 75% of tipping capacity with front linkage fully extended at ground line with bucket curled.

Capacity based on ISO 7451.

Bucket weight with Long tips.

Caterpillar recommends using appropriate work tools to maximize the value customers receive from our products. Use of work tools, including buckets, which are outside of Caterpillar's recommendations or specifications for weight, dimensions, flows, pressures, etc. may result in less-than-optimal performance, including but not limited to reductions in production, stability, reliability, and component durability. Improper use of a work tool resulting in sweeping, prying, twisting and/or catching of heavy loads will reduce the life of the boom and stick.

Maximum Material Density:

- 2100 kg/m³
- ⊙ 1800 kg/m³
- ⊖ 1500 kg/m³
- 1200 kg/m³
- ◇ 900 kg/m³
- ⊗ Not Recommended

374F L Hydraulic Excavator Specifications

Bucket Specifications and Compatibility

	Linkage	Width	Capacity	Weight	Fill Factor	Reach Boom				Mass Boom	
						2.84 m	3.60 m	4.15 m	4.67 m	2.57 m	3.00 m
						900 mm DG (Standard)				900 mm DG (Standard)	
Tracks	mm	m ³	kg	%							
Without Quick Coupler											
General Duty (GD)	VB2	1525	2.90	3205	100	●	●	●	⊙		
	VB2	1900	3.80	3622	100	●	⊙	⊖	○		
	VB2	1900	3.80	3720	100	●	⊙	⊖	○		
	WB2	2000	4.60	4016	100					●	⊙
	WB2	2100	5.00	4167	100					⊙	⊙
General Duty XL (GDXL)	VB2	2000	4.60	4077	100	⊖	○	○	◇		
Heavy Duty (HD)	VB2	1220	2.20	2892	100	●	●	●	●		
	VB2	1700	3.30	3529	100	●	●	⊙	⊖		
	VB2	1900	3.80	3881	100	⊙	⊖	⊖	○		
	VB2	1900	3.80	3782	100	⊙	⊖	⊖	○		
	WB2	2100	5.00	4345	100					⊙	⊙
	WB2	2250	5.30	4591	100					⊙	⊖
Severe Duty (SD)	VB2	1100	1.90	2840	90	●	●	●	●		
	VB2	1525	2.90	3453	90	●	●	●	⊙		
	VB2	1700	3.30	3653	90	●	●	⊙	⊖		
	VB2	1900	3.80	4016	90	●	⊙	⊖	○		
	WB2	1800	3.70	4667	90					●	●
	WB2	1900	4.00	4825	90					●	●
	WB2	2000	4.40	4982	90					●	●
	WB2	2100	4.60	5141	90					●	⊙
	WB2	2200	4.60	5227	90					●	⊙
	WB2	2200	5.00	5341	90					⊙	⊖
Extreme Duty (XD)	VB2	1900	3.80	4806	90	⊙	⊖	○	◇		
	WB2	1900	4.00	5587	90					●	●
	WB2	2000	4.40	5785	90					●	⊙
	WB2	2100	4.40	5866	90					●	⊙
	WB2	2150	4.60	5982	90					⊙	⊖
	WB2	2200	5.00	6171	90					⊙	⊖
Extreme Duty Granite (XDG)	WB2	2000	4.37	5992	90					●	⊙
	WB2	2100	4.64	6224	90					⊙	⊖
Maximum load pin-on (payload + bucket)					kg	11 349	10 264	9448	8627	13 966	12 907
With Quick Coupler (CW-70)											
General Duty (GD)	VB2	1900	3.80	3668	100	⊖	○	◇	◇		
Severe Duty (SD)	WB2	1900	4.00	4802	90					●	⊙
	WB2	2000	4.40	4959	90					⊙	⊖
Extreme Duty (XD)	WB2	2000	4.40	5797	90					⊖	○
Maximum load pin-on (payload + bucket)					kg	10 029	8944	8128	7307	12 646	11 587

Maximum Material Density:

- 2100 kg/m³
- ⊙ 1800 kg/m³
- ⊖ 1500 kg/m³
- 1200 kg/m³
- ◇ 900 kg/m³

The above loads are in compliance with hydraulic excavator standard EN474, they do not exceed 87% of hydraulic lifting capacity or 75% of tipping capacity with front linkage fully extended at ground line with bucket curled.

Capacity based on ISO 7451.

Bucket weight with Long tips.

Caterpillar recommends using appropriate work tools to maximize the value customers receive from our products. Use of work tools, including buckets, which are outside of Caterpillar's recommendations or specifications for weight, dimensions, flows, pressures, etc. may result in less-than-optimal performance, including but not limited to reductions in production, stability, reliability, and component durability. Improper use of a work tool resulting in sweeping, prying, twisting and/or catching of heavy loads will reduce the life of the boom and stick.

374F L Hydraulic Excavator Specifications

Work Tool Offering Guide*

Boom Type	Reach Boom		
	4.67 m HD	4.15 m HD	3.60 m HD
Hydraulic Hammer	H160E s	H160E s	H160E s
	H180E s	H180E s	H180E s
Muti Processor	MP40 CC Jaw	MP40 CC Jaw	MP40 CC Jaw
	MP40 CR Jaw	MP40 CR Jaw	MP40 CR Jaw
	MP40 PS Jaw**	MP40 PS Jaw	MP40 PS Jaw
	MP40 S Jaw**	MP40 S Jaw	MP40 S Jaw
Mobile Scrap and Demolition Shear	S365C**	S365C^^	S365C
	S385C##	S385C##	S385C##
Orange Peel Grapple			
Rippers			
Center-Lock™ Pin Grabber Coupler			
Dedicated Quick Coupler			

These work tools are available for the 374F L.
Consult your Cat dealer for proper match.

*Matches are dependent on excavator configurations. Consult your Cat dealer for proper work tool match.

**Pin-on only.

##Boom mount.

^^Over the front only with CL coupler.

Work Tool Offering Guide*

Boom Type	Reach Boom		Mass Boom
	2.84 m HD	3.00 m	2.57 m
Hydraulic Hammer	H160E s	H160E s	H160E s
	H180E s	H180E s	H180E s
Muti Processor	MP40 CC Jaw	MP40 CC Jaw	MP40 CC Jaw
	MP40 CR Jaw	MP40 CR Jaw	MP40 CR Jaw
	MP40 PS Jaw	MP40 PS Jaw	MP40 PS Jaw
	MP40 S Jaw	MP40 S Jaw	MP40 S Jaw
Crusher	P360	P360	P360
Mobile Scrap and Demolition Shear	S365C	S365C	S365C
	S385C##	S385C##	S385C##
Orange Peel Grapple			
Clamshell			
Rippers			
Center-Lock Pin Grabber Coupler			
Dedicated Quick Coupler			

These work tools are available for the 374F L.
Consult your Cat dealer for proper match.

*Matches are dependent on excavator configurations. Consult your Cat dealer for proper work tool match.

##Boom mount.

374F L Standard Equipment

Standard Equipment

Standard equipment may vary. Consult your Cat dealer for details.

CAB

- Parallel wiper and washer
- Mirrors
- Pressurized operator station with positive filtration
- Laminated glass front upper window and tempered other windows
- Sliding upper door window (left-hand cab door)
- Removable lower windshield with in cab storage bracket
- Openable skylight
- Interior:
 - Glass-breaking safety hammer
 - Coat hook
 - Beverage holder
 - Literature holder
 - Interior lighting
 - AM/FM radio mounting (DIN size)
 - Two 12V stereo speakers
 - Storage shelf suitable for lunch or toolbox
 - Power supply with 12V, two power outlets (10 amp)
 - Thumb wheel modulation joystick for use with combined auxiliary control
 - Sun screen
 - Air conditioner, heater and defroster with climate control
- Seat:
 - Seat belt, 76 mm
 - Adjustable armrest
 - Height adjustable joystick consoles
 - Neutral lever (lock out) for all controls
 - Travel control pedals with removable hand levers
 - Capability of installing two additional pedals
 - Two speed travel
 - Floor mat, washable

Monitor:

- Clock
- Video ready
- Color LCD display with warning, filter/fluid change, and working hour information
- Language display (full graphic and full color display)
- Machine condition, error code and tool mode setting information
- Start-up level check for engine oil, engine coolant and hydraulic oil
- Warning, filter/fluid change and working hour information
- Fuel consumption meter

ELECTRICAL

- 80 amp alternator
- Circuit breaker
- Battery, standard

ENGINE

- C15 ACERT diesel engine
- EU Stage IV emission package
- 2300 m altitude capability with no derate
- Up to B20 biodiesel capable
- Automatic engine speed control
- Electric priming pump with switch
- Water separator in fuel line including water level sensor and indicator
- Economy and standard power modes
- Air cleaner
- Side-by-side cooling system
- Steel wall between engine and pump compartment
- Primary filter with water separator and water separator indicator switch
- Starting kit, cold weather, –18° C
- Primary fuel filter
- Secondary fuel filter
- Tertiary fuel filter

HYDRAULIC SYSTEM

- Reverse swing dampening valve
- Automatic swing parking brake
- High-performance hydraulic return filter
- Regeneration circuit for boom and stick
- Capability of installing additional auxiliary circuits
- Reversing cooling fan
- Bio oil capable
- SmartBoom

LIGHTS

- Cab and boom lights with time delay
- Exterior lights integrated into storage box

UNDERCARRIAGE/UPPERFRAME

- Grease Lubricated Track with PPR2 GLT4, resin seal
- Heavy duty track roller and idler
- Heavy duty track motor guards
- Towing eye on base frame
- Heavy duty bottom guards on upperframe
- Counterweight with lifting eye
- Swivel guard

SAFETY AND SECURITY

- Cat one key security system
- Door locks
- Cap locks on fuel and hydraulic tanks
- Lockable external tool/storage box
- Signaling/warning horn
- Secondary engine shutoff switch
- Mirrors
- Rear window for emergency exit
- Rear vision camera
- Capability to connect a beacon
- Bolt on FOGS capability
- Service walkways
- Safety hammer for breaking cab glass

INTEGRATED TECHNOLOGIES

- Product Link
- Rear vision camera

Optional Equipment

Optional equipment may vary. Consult your Cat dealer for details.

FRONT LINKAGE

- Reach boom 7.8 m
(with or without BLCV/SLCV):
 - R4.67 VB2 (with or without CGC)
 - R4.15VB2 (without CGC)
 - R3.6VB2 (with or without CGC)
 - R2.84VB2 (without CGC)
 - VB2 – family bucket linkage
(with or without lifting eye)
- Mass boom 7.0 m
(with or without BLCV/SLCV):
 - M3.0WB2
 - M2.57WB2 abrasive
 - M2.57WB2
 - WB2 – family bucket linkage
(with or without lifting eye)

TRACK

- 650 mm Double Grouser Heavy Duty
- 750 mm Double Grouser Heavy Duty
- 900 mm Double Grouser Heavy Duty

ENGINE

- Quick drains, engine and hydraulic oil
(QuickEvac)
- Fast fill port for fuel

GUARDS

- FOGS (Falling Object Guard System)
including overhead and windshield guards
- TOP guard including overhead guards
- Track guiding guards:
 - Full length
 - Segmented, 3 pieces
 - Center section

LIGHTS

- Cab working lights, halogen
- Cab working lights, HID
- Boom working lights, halogen
- Boom working lights, HID

CAB

- Seat:
 - Adjustable high-back, heated seat
with air suspension
 - Adjustable high-back, heated and
ventilated seat with air suspension
- Cab front rain protector
- Windshield:
 - 70-30 split, sliding
 - One-piece, fixed
- Straight travel pedal

HYDRAULIC SYSTEM

- Boom and stick lowering control devices
with SmartBoom
- Counterweight removal device
- HP hydraulic lines for boom and stick
- MP hydraulic lines for boom and stick
- QC hydraulic lines for boom and stick
- Universal QC control
- Bio oil

ELECTRICAL

- Cold weather starting package, 240V
- Travel alarm
- Electric refueling pump

INTEGRATED TECHNOLOGIES

- Cat Grade Control depth and slope

For more complete information on Cat products, dealer services, and industry solutions, visit us on the web at www.cat.com

© 2016 Caterpillar
All rights reserved

Materials and specifications are subject to change without notice. Featured machines in photos may include additional equipment. See your Cat dealer for available options.

CAT, CATERPILLAR, SAFETY.CAT.COM, their respective logos, "Caterpillar Yellow" and the "Power Edge" trade dress, as well as corporate and product identity used herein, are trademarks of Caterpillar and may not be used without permission.

VisionLink is a trademark of Trimble Navigation Limited, registered in the United States and in other countries.

AEHQ7262-02 (01-2016)
Replaces AEHQ7262-01
(Europe)

