

# 259D/279D/289D

Compact Track Loaders



<b>Cat® C3.3B DIT (Turbo) Engine</b>	<b>259D</b>		<b>279D</b>		<b>289D</b>	
Gross Power (SAE J1995)	55.4 kW	74.3 hp	55.4 kW	74.3 hp	55.4 kW	74.3 hp
<b>Weights</b>						
Operating Weight	4013 kg	8,846 lb	4487 kg	9,893 lb	4778 kg	10,533 lb
<b>Operating Specifications</b>						
Rated Operating Capacity at 50% Tipping Load	1315 kg	2,900 lb	1331 kg	2,935 lb	1724 kg	3,800 lb

## 259D/279D/289D Features

### Industry Leading Cab

*One piece, modular design provides a premium sealed and pressurized cab for a cleaner and quieter operating environment with excellent all around visibility.*

### Superior Power

*High performance power train provides maximum performance with features such as Electronic Torque Management system, standard two speed and an industry exclusive hand/foot throttle with decel pedal capability.*

### Powerful Hydraulics

*High flow hydraulic system available for applications that demand maximum hydraulic work tool performance.*

### Suspended Undercarriage

*Standard suspended undercarriage system provides superior traction, flotation and speed to work in a wide range of applications and underfoot conditions.*

### Outstanding Performance

*Cat Intelligent Leveling (ILEV) system enables industry leading features such as electronic self level, return-to-dig and work tool positioner.*

### Versatility

*Do more with one machine with the broad range of Cat Work Tools, built to get the most out of your machine.*

### Contents

Operator Station.....	4
Power Train.....	6
Lift Linkages.....	6
Steel Embedded Rubber Track Undercarriage.....	7
Performance.....	7
Attachments.....	8
Serviceability.....	9
Customer Support.....	9
Specifications.....	10
Standard Equipment.....	14
Mandatory Equipment.....	15
Optional Equipment.....	15





**Experience the difference of a Cat Compact Track Loader. Spacious operator station features ergonomic joystick controls, ample leg room and an available high back, heated, air ride seat to keep you comfortable all day long. Built for low ground pressure with outstanding performance, comfort and versatility, the Cat D Series Compact Track Loaders help you get more done to improve your bottom line.**

# Operator Station

Spacious working environment for all day comfort.



## Base Display

The standard control monitor provides a single-code security to help prevent theft and unwanted operation.

## Best Seat on the Job Site

High back, heated, air ride seat available in both cloth and vinyl.

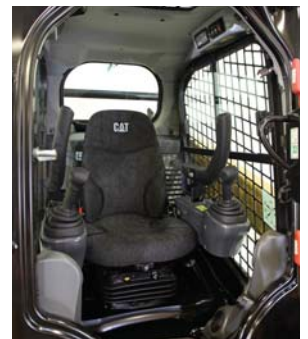



## Superior Comfort

The Cat D Series sets a new standard in operator comfort. The wide, spacious interior and uncluttered floor helps you work comfortably and productively all day long. Features include:

- One piece, modular design provides a premium sealed and pressurized cab for cleaner and quieter working environment
- High back, heated, air ride seat with seat-mounted joystick controls for added comfort (option)
- Clear sight lines provide excellent visibility
- Air conditioner and heater for greater comfort in all climates (option)
- Ample leg room
- Selectable Pattern Control which allows the operator to select the control pattern they are most familiar with for greater productivity (option)

## Advanced Display Panel

The optional Advanced Display lets you customize your machine performance to your needs by offering the ultimate in operator control features and functionality. This easy to read 127 mm (5 in) LCD display puts machine information at your fingertips. It provides on screen adjustments to working parameters and preferences such as implement response adjustment, drive response adjustment, creep setting, ride control activation speed, top speed limit setting, language, background color and gauge display style. All parameters can be customized and retained for each individual operator's code. It also provides:

- Security system to prevent unauthorized machine usage
- Capability to program up to 50 operator codes to store and recall each operator's preferences and working parameters, allowing the machine to be tailored to experience level and application
- Integrated rearview camera for additional job site visibility (option)





*Vertical Lift Linkage*



*Radial Lift Linkage*

## Lift Linkages

### Choice of lift designs.

Two types of lifting arrangement are available – vertical lift and radial lift – to meet your specific application needs.

#### **Vertical Lift**

The 259D and 289D feature the vertical lift design which provides extended reach and lift height for material handling or quick and easy truck loading.

#### **Radial Lift**

The 279D features the radial lift design which delivers excellent digging performance and superior mid-lift reach.

# Power Train

## Aggressive performance.

#### **Cat Engine**

The rugged and reliable Cat C3.3B engine delivers high horsepower and torque to match your performance and application needs.

#### **Cat Intelligent Leveling (ILEV) System**

The exclusive Cat Intelligent Leveling System takes machine performance to a new level and provides industry leading features such as:

- Electronic snubbing that automatically cushions the descent of the lift arms, slowing the downward motion just before the arms reach their stops
- Return-to-dig which allows the operator to pre-set the digging angle of the bucket and then automatically lowers the lift arms and recalls the bucket angle
- Work Tool Positioner which allows the angle of the work tool (bucket, box rake, cold planer, forks, trencher, etc.) to be pre-set and then automatically recalled if the machine is repositioned, increasing productivity

#### **Electronic Throttle**

New electronic dial-type throttle lets you set precise RPM setting. When the dial is in the high-idle position, the foot throttle functions as a decelerator pedal. This gives you greater control, allowing you to quickly adjust the travel speed during precise maneuvers or to regulate engine speed when using hydro-mechanical work tools. A new throttle-smoothing feature monitors the accelerator pedal's movement under the operator's foot when traveling over rough terrain and adjusts to provide a steadier, more even travel speed.



# Steel Embedded Rubber Track Undercarriage

Suspended undercarriage for versatility, comfort and durability.

The Cat Compact Track Loader features the industry's only standard, fully suspended undercarriage with a steel embedded rubber track. Heavy-duty torsion axles suspend the CTL undercarriage and can move independently relative to the machine and each other. These axles absorb most of the shock to the undercarriage, machine and operator, especially over rough terrain. This means smooth travel, even at high speeds, as well as better load retention and greater productivity. The tread design ensures a smooth ride and a great combination of traction and flotation.

## Outstanding Durability

The CTL undercarriage system features highly durable and easily maintained components. Steel imbeds provide a rigid support for the entire width of the track and provide excellent durability in a wide variety of applications. Continuously wound cables hold these imbeds in place and provide tensile strength, ensuring the track does not stretch. Following the same philosophy as Cat Track-Type Tractors, the elevated external positive drive system keeps drive components away from ground debris. Planetary final drive motors improve torque and drawbar performance, delivering more power to the ground. Steel rollers with metal face seals provide maximum protection for wheel bearings resulting in long-term durability and reliability in even the toughest conditions. The simple recoil grease tensioning system allows quick track tension adjustment.



## Performance

Solutions for a wide range of applications.

### High Performance Hydraulic System

Maximum power and reliability are built into the Cat hydraulic system to help you get the job done faster. The hydraulic system features outstanding lift and breakout forces. The available continuous demand fan provides improved fuel efficiency and increased horsepower.

### High Flow Hydraulic Systems

High Flow (259D) and High Flow XPS (279D/289D) hydraulic systems are available for applications that demand maximum work tool performance.

### Two Speed

Increase your productivity with standard Two Speed.

### Ride Control

The optional Speed Sensitive Ride Control system delivers a smoother ride on uneven terrain for superior comfort, higher speed operation and better material retention.



# Attachments

Do more jobs with one machine using Cat Work Tools.

## The Right Tool for the Job

Designed and built for optimum performance and durability, Cat Work Tools deliver high productivity in a variety of applications to maximize versatility:

- Augers
- Backhoes
- Blades (angle, dozer)
- Buckets (general purpose, high capacity, dirt, utility, light material, multi purpose, industrial grapple, utility grapple)
- Brooms (angle, pickup, utility)
- Brushcutters
- Cold Planers
- Forks (pallet, industrial grapple, utility grapple, utility)
- Hydraulic Hammers
- Landscape Tillers
- Landscape Rakes
- Material Handling Arm
- Mulchers
- Power Box Rakes
- Sectional Snow Push
- Shear
- Snow Blowers
- Stump Grinders
- Trenchers
- Vibratory Compactors
- Wheel Saws

## Quick Couplers

Work tools can be changed quickly and easily with the Cat Compact Track Loader's quick coupler system. The standard quick coupler features manual engagement and disengagement of work tools using two high leverage handles. The optional electric quick coupler allows the operator to quickly change tools without leaving the cab.





# Serviceability

Easy maintenance helps keep your machine working.

## Minimize Your Downtime

Convenient service features make maintenance easy, reducing your downtime:

- Unmatched ground level access to all routine service points
- Wide opening rear door for easy access to both sides of the engine
- Electric priming pump with automatic air bleed for the fuel system eliminates the need to pre-fill filters with fuel, reducing the risk of contaminants
- Cat Product Link™ system provides remote reporting of machine location and operating system parameters (optional)

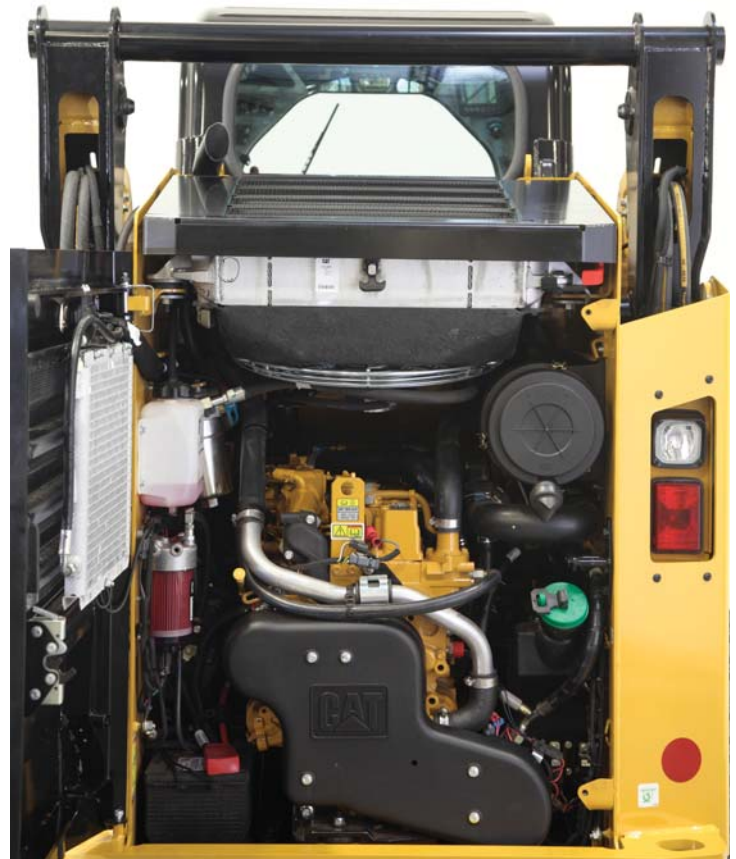

## Customer Support

Unmatched support makes the difference.



## Renowned Dealer Support

From helping you choose the right machine to knowledgeable ongoing support, Cat dealers provide the best in sales and service.

- Preventive maintenance programs and guaranteed maintenance contracts
- Best-in-class parts availability
- Operator training to help boost your profits
- Genuine Cat Remanufactured parts

# 259D/279D/289D Compact Track Loaders Specifications

## Engine

Engine Model	Cat C3.3B DIT (turbo)	
Gross Power (SAE J1995)		
259D	55.4 kW	74.3 hp
279D/289D	55.4 kW	74.3 hp
Net Power (SAE 1349)		
259D	53.8 kW	72.1 hp
	54.2 kW†	72.7 hp†
279D/289D	53.6 kW	71.8 hp
	54.0 kW†	72.4 hp†
Net Power (ISO 9249)		
259D	54.3 kW	72.8 hp
	54.8 kW†	73.5 hp†
279D/289D	54.1 kW	72.6 hp
	54.6 kW†	73.2 hp†
Displacement	3.3 L	203 in <sup>3</sup>
Stroke	120 mm	4.7 in
Bore	94 mm	3.7 in

† Tier 4 Interim equivalent engine offered only for Canada, Australia/New Zealand, Macedonia, Ukraine and South Korea.

## Weights\*

Operating Weight		
259D	4013 kg	8,846 lb
279D	4487 kg	9,893 lb
289D	4778 kg	10,533 lb

## Power Train

Travel Speed (Forward or Reverse)		
One Speed		
259D	9.5 km/h	5.9 mph
279D/289D	8.4 km/h	5.2 mph
Two Speed		
259D	13.7 km/h	8.5 mph
279D/289D	13.5 km/h	8.4 mph

## Operating Specifications\*

Rated Operating Capacity at 35% Tipping Load		
259D	921 kg	2,030 lb
279D	932 kg	2,055 lb
289D	1207 kg	2,660 lb

Rated Operating Capacity at 50% Tipping Load		
259D	1315 kg	2,900 lb
279D	1331 kg	2,935 lb
289D	1724 kg	3,800 lb

Rated Operating Capacity with Optional Counterweight		
259D	1406 kg	3,100 lb
279D	1444 kg	3,185 lb
289D	1837 kg	4,050 lb

Tipping Load		
259D	2631 kg	5,800 lb
279D	2663 kg	5,870 lb
289D	3447 kg	7,600 lb

Breakout Force, Tilt Cylinder		
259D	2284 kg	5,035 lb
279D	3304 kg	7,285 lb
289D	3307 kg	7,291 lb

Ground Contact Area		
259D (with 320 mm/12.6 in track)	0.96 m <sup>2</sup>	1,483 in <sup>2</sup>
259D (with 400 mm/15.7 in track)	1.19 m <sup>2</sup>	1,848 in <sup>2</sup>
279D (with 400 mm/15.7 in track)	1.30 m <sup>2</sup>	2,015 in <sup>2</sup>
279D (with 450 mm/17.7 in track)	1.47 m <sup>2</sup>	2,272 in <sup>2</sup>
289D (with 400 mm/15.7 in track)	1.30 m <sup>2</sup>	2,015 in <sup>2</sup>
289D (with 450 mm/17.7 in track)	1.47 m <sup>2</sup>	2,272 in <sup>2</sup>

Ground Pressure		
259D (with 320 mm/12.6 in track)	41.1 kPa	6.0 psi
259D (with 400 mm/15.7 in track)	33.4 kPa	4.8 psi
279D (with 400 mm/15.7 in track)	33.9 kPa	4.9 psi
279D (with 450 mm/17.7 in track)	30.0 kPa	4.4 psi
289D (with 400 mm/15.7 in track)	36.1 kPa	5.2 psi
289D (with 450 mm/17.7 in track)	32.0 kPa	4.6 psi

# 259D/279D/289D Compact Track Loaders Specifications

## Hydraulic System – 259D

### Hydraulic Flow – Standard

Loader Hydraulic Pressure	23 000 kPa	3,335 psi
Loader Hydraulic Flow	76 L/min	20 gal/min
Hydraulic Power (calculated)	29 kW	39 hp

### Hydraulic Flow – High Flow

Maximum Loader Hydraulic Pressure	23 000 kPa	3,335 psi
Maximum Loader Hydraulic Flow	112 L/min	30 gal/min
Hydraulic Power (calculated)	43 kW	58 hp

## Hydraulic System – 279D and 289D

### Hydraulic Flow – Standard

Loader Hydraulic Pressure	23 000 kPa	3,335 psi
Loader Hydraulic Flow	86 L/min	23 gal/min
Hydraulic Power (calculated)	33 kW	44 hp

### Hydraulic Flow – High Flow XPS

Maximum Loader Hydraulic Pressure	28 000 kPa	4,061 psi
Maximum Loader Hydraulic Flow	121 L/min	32 gal/min
Hydraulic Power (calculated)	57 kW	76 hp

## Cab

ROPS	ISO 3471:2008
FOPS	ISO 3449:2005 Level I
FOPS Level II	ISO 3449:2005 Level II

## Service Refill Capacities

Cooling System	14 L	3.7 gal
Engine Crankcase	11 L	3.0 gal
Fuel Tank		
259D	105 L	27.7 gal
279D/289D	94 L	24.8 gal
Hydraulic System		
259D	50 L	13.2 gal
279D/289D	52 L	13.7 gal
Hydraulic Tank	39 L	10.3 gal

# 259D/289D Compact Track Loaders Specifications

## Dimensions\*

All dimensions are approximate.

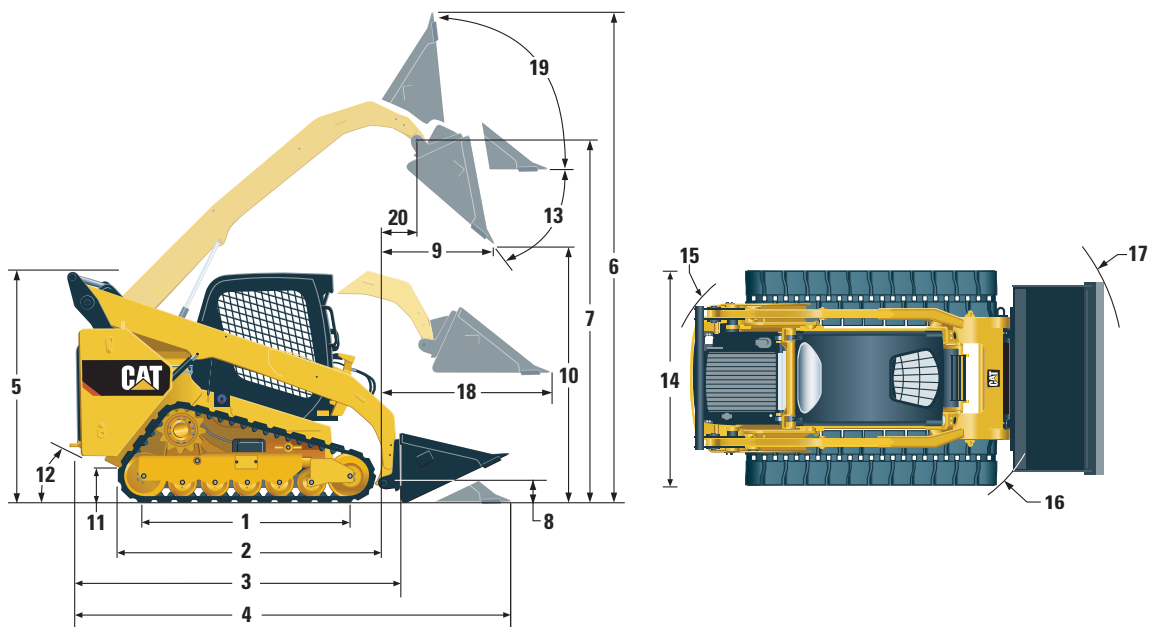

	259D		289D	
1 Length of Track on Ground	1499 mm	59.0 in	1630 mm	64.2 in
2 Overall Length of Track	1999 mm	78.7 in	2129 mm	83.8 in
3 Length without Bucket	2767 mm	108.9 in	2995 mm	117.9 in
4 Length with Bucket on Ground	3486 mm	137.3 in	3714 mm	146.2 in
5 Height to Top of Cab	2111 mm	83.1 in	2113 mm	83.2 in
6 Maximum Overall Height	3915 mm	154.1 in	4051 mm	159.5 in
7 Bucket Pin Height at Maximum Lift	3075 mm	121.0 in	3178 mm	125.1 in
8 Bucket Pin Height at Carry Position	198 mm	7.8 in	190 mm	7.5 in
9 Reach at Maximum Lift and Dump	608 mm	23.9 in	761 mm	30.0 in
10 Clearance at Maximum Lift and Dump	2283 mm	89.9 in	2387 mm	94.0 in
11 Ground Clearance	226 mm	8.9 in	226 mm	8.9 in
12 Departure Angle	35°		33°	
13 Maximum Dump Angle	52°		51°	
14 Vehicle Width (320 mm/12.6 in tracks) – 259D only	1676 mm	66.0 in	N/A	
Vehicle Width (400 mm/15.7 in tracks) – 259D/289D	1755 mm	69.0 in	1931 mm	76.0 in
Vehicle Width (450 mm/17.7 in tracks) – 289D only	N/A		1981 mm	78.0 in
15 Turning Radius from Center – Machine Rear	1561 mm	61.5 in	1796 mm	70.7 in
16 Turning Radius from Center – Coupler	1392 mm	54.8 in	1410 mm	55.5 in
17 Turning Radius from Center – Bucket	2184 mm	86.0 in	2256 mm	88.8 in
18 Maximum Reach with Arms Parallel to Ground	1305 mm	51.4 in	1270 mm	50.0 in
19 Rack Back Angle at Maximum Height	87°		84°	
20 Bucket Pin Reach at Maximum Lift	238 mm	9.4 in	369 mm	14.5 in

\*Operating Weight, Operating Specifications and Dimensions for the 259D and 289D all based on 75 kg (165 lb) operator, all fluids, two speed, OROPS, 1676 mm (66 in) dirt bucket, 320 mm (12.6 in) tracks for the 259D or 400 mm (15.7 in) tracks for the 289D, dual flange front idler/single flange rear idler, standard flow hydraulics, mechanical suspension seat, no optional counterweights and manual quick coupler (unless otherwise noted).

# 279D Compact Track Loaders Specifications

## Dimensions\*

All dimensions are approximate.

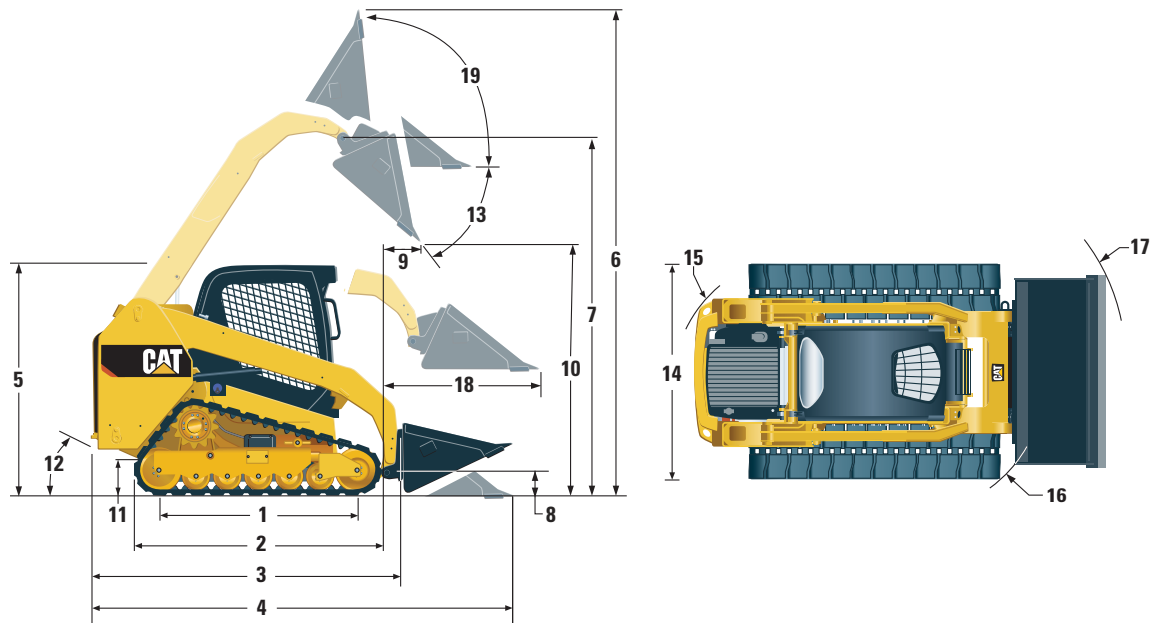

	<b>279D</b>	
<b>1</b> Length of Track on Ground	1630 mm	64.2 in
<b>2</b> Overall Length of Track	2129 mm	83.8 in
<b>3</b> Length without Bucket	2995 mm	117.9 in
<b>4</b> Length with Bucket on Ground	3714 mm	146.2 in
<b>5</b> Height to Top of Cab	2113 mm	83.2 in
<b>6</b> Maximum Overall Height	4051 mm	159.5 in
<b>7</b> Bucket Pin Height at Maximum Lift	3173 mm	124.9 in
<b>8</b> Bucket Pin Height at Carry Position	198 mm	7.8 in
<b>9</b> Reach at Maximum Lift and Dump	575 mm	22.6 in
<b>10</b> Clearance at Maximum Lift and Dump	2485 mm	97.8 in
<b>11</b> Ground Clearance	226 mm	8.9 in
<b>12</b> Departure Angle		32°
<b>13</b> Maximum Dump Angle		39°
<b>14</b> Vehicle Width (400 mm/15.7 in tracks)	1931 mm	76.0 in
Vehicle Width (450 mm/17.7 in tracks)	1981 mm	78.0 in
<b>15</b> Turning Radius from Center – Machine Rear	1796 mm	70.7 in
<b>16</b> Turning Radius from Center – Coupler	1410 mm	55.5 in
<b>17</b> Turning Radius from Center – Bucket	2256 mm	88.8 in
<b>18</b> Maximum Reach with Arms Parallel to Ground	1373 mm	54.0 in
<b>19</b> Rack Back Angle at Maximum Height		84°

\*Operating Weight, Operating Specifications and Dimensions for the 279D all based on 75 kg (165 lb) operator, all fluids, two speed, OROPS, 1676 mm (66 in) dirt bucket, 400 mm (15.7 in) tracks, dual flange front idler/single flange rear idler, standard flow hydraulics, mechanical suspension seat, no optional counterweights and manual quick coupler (unless otherwise noted).

# 259D/279D/289D Standard Equipment

## Standard Equipment

Standard equipment may vary. Consult your Cat dealer for details.

### ELECTRICAL

- 12 volt Electrical System
- 80 ampere Alternator
- Ignition Key Start/Stop Switch
- Lights: Gauge Backlighting, Two Rear Tail Lights, Two Rear Halogen Working Lights, Two Adjustable Front Halogen Lights, Dome Light
- Backup Alarm
- Heavy Duty Battery, 880 CCA

### OPERATOR ENVIRONMENT

- Gauges: Fuel Level, Hour Meter
- Operator Warning System Indicators: Air Filter Restriction, Alternator Output, Armrest Raised/Operator Out of Seat, Engine Coolant Temperature, Engine Oil Pressure, Glow Plug Activation, Hydraulic Filter Restriction, Hydraulic Oil Temperature, Park Brake Engaged, Engine Emission System
- Adjustable Vinyl Seat
- Fold In Ergonomic Contoured Armrest
- Control Interlock System, when operator leaves seat or armrest raised: Hydraulic System Disables, Hydrostatic Transmission Disables, Parking Brake Engages
- ROPS Cab, Open, Tilt Up
- FOPS, Level I

- Top and Rear Windows
- Floor Mat
- Interior Rearview Mirror
- 12 volt Electric Socket
- Horn
- Hand (Dial) Throttle, Electronic
- Adjustable Joystick Controls
- Anti-theft Security System with six-button Keypad
- Storage Compartment with Netting

### POWER TRAIN

- Cat C3.3B, Turbo Diesel Engine
- Air Cleaner, Dual Element, Radial Seal
- S·O·S<sup>SM</sup> Sampling Valve, Hydraulic Oil
- Filters, Cartridge-type, Hydraulic
- Filters, Cartridge-type, Fuel and Water Separator
- Radiator/Hydraulic Oil Cooler (side-by-side)
- Spring Applied, Hydraulically Released Parking Brakes
- Hydrostatic Transmission

### OTHER

- Engine Enclosure, Lockable
- Extended Life Antifreeze, -36° C (-33° F)
- Machine Tie Down Points (6)
- Support, Lift Arm
- Hydraulic Oil Level Sight Gauge
- Radiator Coolant Level Sight Gauge
- Radiator, Expansion Bottle
- Cat ToughGuard™ Hose
- Auxiliary, Hydraulics, Continuous Flow
- Heavy Duty, Flat Faced Quick Disconnects with Integrated Pressure Release
- Split D-Ring to Route Work Tool Hoses Along Side of Left Lift Arm
- Electrical Outlet, Beacon
- Belly Pan Cleanout
- Variable Speed Demand Fan (standard on 279D/289D; optional on 259D)

# 259D/279D/289D Mandatory Equipment

## Mandatory Equipment

Mandatory equipment may vary. Consult your Cat dealer for details.

- Hydraulics, Standard Flow or High Flow (259D)/High Flow XPS (279D/289D)
- Quick Coupler, Manual or Electric
- Seat Belt, 50 mm (2 in) or 75 mm (3 in)
- Steel Imbed Rubber Track:
  - 259D: 320 mm (12.6 in) or 400 mm (15.7 in)
  - 279D/289D: 400 mm (15.7 in) or 450 mm (17.7 in)
- Dual Flange Front Idler/Single Flange Rear Idler or Triple Flange Front/Rear Idlers

### COMFORT PACKAGES

- Open ROPS (C0): Static Seat (No Foot Throttle, Headliner, Heater or Door)
- Open ROPS (C1): Foot Throttle, Headliner, Cup Holder, and choice of Seat (Mechanical Suspension or High Back, Heated, Air Ride Seat) (No Heater or Door)
- Enclosed ROPS with Heater (C2): Foot Throttle, Headliner, Heater and Defroster, Side Windows, Cup Holder, Radio Ready, choice of Seat (Mechanical Suspension or High Back, Heated, Air Ride Seat) and Door (Glass or Polycarbonate)
- Enclosed ROPS with A/C (C3): C2 + Air Conditioner

### PERFORMANCE PACKAGES FOR THE 259D

- Performance Package H1: Standard Flow Hydraulics (No Self Level)
- Performance Package H2: Standard Flow Hydraulics, Single Direction Electronic Self Level (Raise), Electronic Snubbing (Raise and Lower)
- Performance Package H3: High Flow Hydraulics, Single Direction Electronic Self Level (Raise), Electronic Snubbing (Raise and Lower)

### PERFORMANCE PACKAGES FOR THE 279D

- Performance Package H1: Standard Flow Hydraulics (No Self Level)
- Performance Package H3: High Flow XPS, Dual Direction Electronic Self Level (Raise and Lower), Electronic Snubbing (Raise and Lower)
- Performance Package H4: Standard Flow Hydraulics (No Self Level), Return to Dig/Work Tool Positioner, Electronic Snubbing (Raise and Lower)

### PERFORMANCE PACKAGES FOR THE 289D

- Performance Package H1: Standard Flow Hydraulics (No Self Level)
- Performance Package H2: Standard Flow, Dual Direction Electronic Self Level (Raise and Lower), Electronic Snubbing (Raise and Lower)
- Performance Package H3: High Flow XPS, Dual Direction Electronic Self Level (Raise and Lower), Electronic Snubbing (Raise and Lower)

# 259D/279D/289D Optional Equipment

## Optional Equipment

Optional equipment may vary. Consult your Cat dealer for details.

- External Counterweights
- Variable Speed Demand Fan (259D)
- Beacon, Rotating
- Engine Block Heater – 120V
- Oil, Hydraulic, Cold Operation
- Paint, Custom
- Heavy Duty Battery, 1,000 CCA (279D/289D only)
- Product Link, Cellular
- Ride Control
- Advanced Display: Full Color, 127 mm (5 in) LCD screen, Advanced Multi-operator Security System, On-screen Adjustments for Implement Response, Hystat Response, and Creep Control; Rearview Camera Ready
- Advanced Display: Rearview Camera Included
- Work Tool Return to Dig and Work Tool Positioner
- Bluetooth Radio with Microphone (AM/FM/Weather Band Receiver with USB and Auxiliary Input Jack)

For more complete information on Cat products, dealer services, and industry solutions, visit us on the web at [www.cat.com](http://www.cat.com)

AEHQ7256 (04-2014)

© 2014 Caterpillar  
All rights reserved

Materials and specifications are subject to change without notice. Featured machines in photos may include additional equipment. See your Cat dealer for available options.

CAT, CATERPILLAR, SAFETY.CAT.COM, their respective logos, "Caterpillar Yellow" and the "Power Edge" trade dress, as well as corporate and product identity used herein, are trademarks of Caterpillar and may not be used without permission.

