

336D2/D2 L

Hydraulic Excavator



Engine

Engine Model	Cat® C9 ACERT™	
Engine Power (ISO 14396)	209 kW	280 hp
Net Power (SAE J1349/ISO 9249)	201 kW	270 hp

Weights

Operating Weight – Standard Undercarriage	34 489 kg	76,035 lb
Operating Weight – Long Undercarriage	37 086 kg	81,761 lb

336D2/D2 L Differentiating Features

Engine and Hydraulics

A powerful Cat C9 ACERT engine that meets U.S. EPA Tier 2, EU Stage II regulations, and China Tier 2 emission regulations combined with a highly efficient hydraulic system deliver excellent performance with low fuel consumption. In fact, the 336D2/D2 L uses up to 8 percent less fuel than its predecessor moving the same amount of material.

Structures

Caterpillar design and manufacturing techniques assure you get outstanding durability and service life in the toughest applications.

Operator Station

The spacious cab features excellent visibility and easy-to-access switches. The monitor features a full-color graphical display that is easy to see and use. Overall, the new cab provides you with a comfortable working environment for maximum production and efficiency.

Reduced Service and Maintenance Cost

Routine service and maintenance can be completed quickly and easily to help you reduce ownership costs. Convenient access points, extended service intervals, and advanced filtration help keep downtime to a minimum.

Complete Customer Support

Your Cat dealer offers a wide range of services that can be set up under a customer support agreement when you purchase your equipment.

Total Solutions

Caterpillar and its extensive dealer network offer a wide variety of solutions designed to meet the unique needs of your business.

Contents

Operator Station.....	4
Engine	6
Hydraulics	7
Structures and Undercarriage	8
Front Linkage	9
Service and Maintenance	10
Complete Customer Support.....	11
Work Tools.....	12
Specifications.....	14
Standard and Optional Equipment	35





The 336D2/D2 L incorporates innovations to improve your job site efficiency through low owning and operating costs, excellent performance, and high versatility.

Operator Station

Comfort and convenience to keep people productive





Cab Structure and Mounts

The cab shell is attached to the frame with viscous rubber mounts, which dampen vibrations and sound levels while enhancing your comfort. Thick steel tubing along the bottom perimeter improves the cab's resistance to fatigue and vibration.

Seat

The suspension seat provides a variety of adjustments to accommodate a wide range of operators. The seat includes a reclining back, upper and lower seat slide adjustments, and height and tilt adjustments to meet your needs for comfort and productivity.

Joystick Control and Console

Low-effort, pilot-operated joystick controls are designed to match your natural wrist and arm position for maximum comfort and minimum fatigue. The right and left joystick console can be adjusted to meet your individual preferences, improving overall comfort and productivity during the course of a long work day.

Climate Control

Positive filtered ventilation with a pressurized cab is standard. Fresh air or re-circulated air can be selected with a switch on the left console.

Windows and Wipers

All glass is affixed directly to the cab to maximize visibility, eliminating window frames. The upper front windshield opens, closes, and stores on the roof above the operator with a one-touch action release system. Pillar-mounted wipers increase your viewing area and offer continuous and intermittent modes.



Monitor

The full-color LCD monitor can be adjusted to minimize glare, and it has the capability of displaying information in 28 languages to meet the needs of today's diverse work force.

Engine

Powerful, reliable, and fuel efficient to deliver more to your bottom line



Emission Standards

The Cat C9 ACERT engine has been designed to meet U.S. EPA Tier 2, EU Stage II, and China Tier 2 emission standards. The engine incorporates proven robust components and precision manufacturing you can count on for reliable and efficient operation.

Filtration System

The engine features an improved filtration system to ensure reliability even with less-than-quality fuel. Service intervals have been extended and the number of filters reduced to maximize your profit potential.

Automatic Engine Speed Control

Automatic engine speed control is activated during no-load or light-load conditions to reduce engine speed – all to help minimize fuel consumption.

Low Sound and Vibration

The Cat C9 ACERT engine is built to run quietly with limited vibration, improving your comfort.

Hydraulics

Power to move more dirt, rock, and debris
with speed and precision

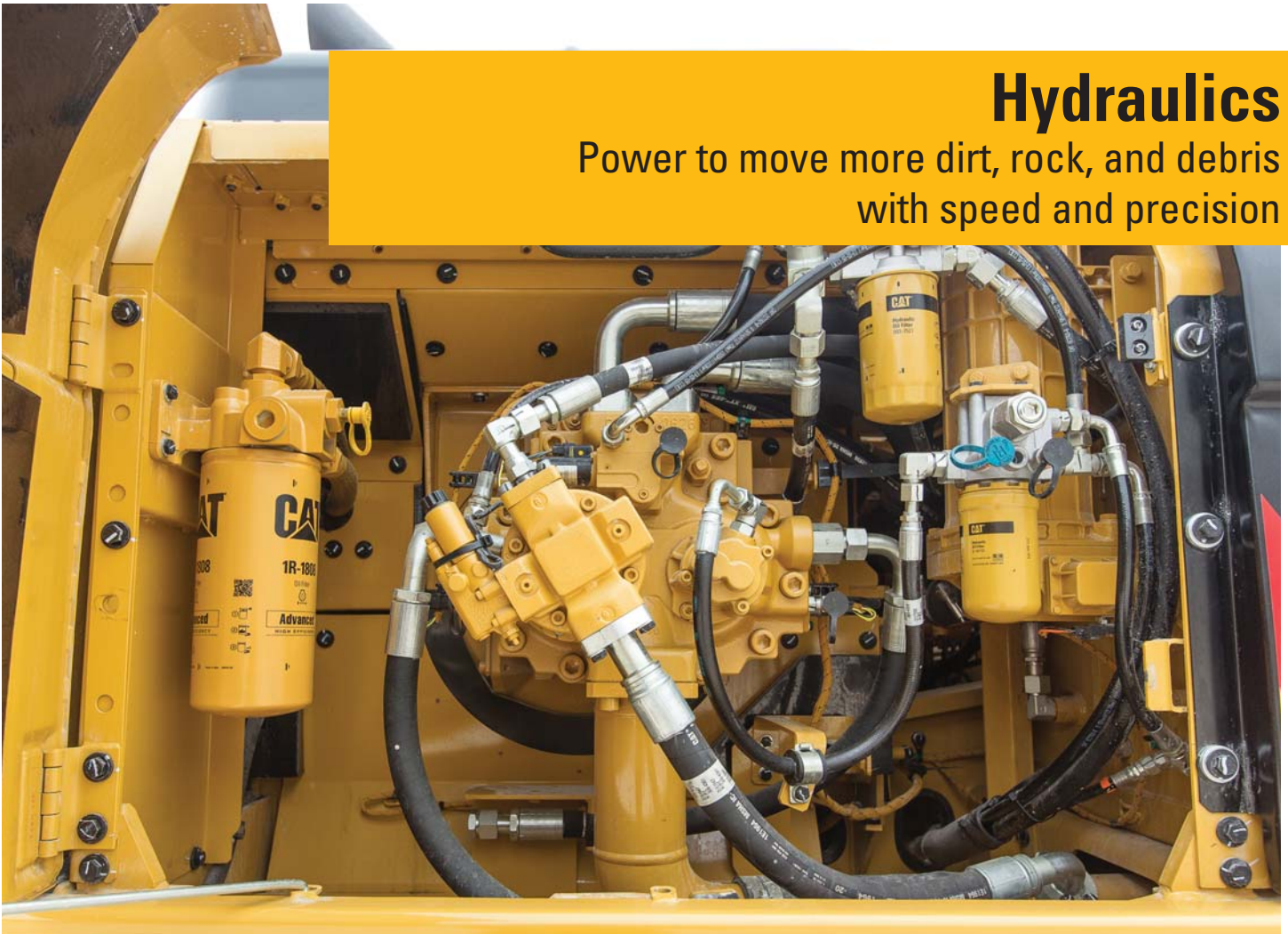

Hydraulic System

Hydraulic system pressure from the two-pump system delivers terrific digging performance and productivity. The hydraulic system and component locations have been designed to provide a high level of system efficiency. The main pumps, control valves, and hydraulic tank are located close together to allow for shorter tubes and lines between components, reducing friction loss and pressure drops.

Pilot System

An independent pilot pump enables smooth, precise control for the front linkage, swing, and travel operations.

Auxiliary Hydraulic Valve

Control circuits are available as attachments to improve versatility. They allow operation of high- and medium-pressure tools such as shears, grapples, hammers, pulverizers, multiprocessors, and vibratory plate compactors.

Boom and Stick Regeneration Circuit

Boom and stick regeneration circuits save energy during boom-down and stick-in operation to increase efficiency and reduce cycle times and pressure loss for higher productivity, lower operating costs, and increased fuel efficiency.

Hydraulic Cylinder Snubbers

Snubbers are located at the rod end of the boom cylinders and both ends of the stick cylinders to cushion shocks while reducing sound levels and extending component life.



Structures and Undercarriage

Built to work in rugged environments

Main Frame

The rugged main frame is built to perform in the toughest applications. The X-shaped, box-section carbody provides excellent resistance to torsional bending, and press-formed, robot-welded track roller frames provide exceptional strength and durability.

Rollers and Idlers

Sealed and lubricated track rollers, carrier rollers, and idlers provide excellent service life to keep your machine in the field and working longer.

Standard Undercarriage

Standard undercarriage is well suited for applications that require frequent machine repositioning; it's also a good choice for restricted work spaces or uneven rocky terrain.

Long Undercarriage

Wide and sturdy long undercarriage offers an excellent platform for applications that require maximum stability and lift capacity.

Counterweight

A 6.0 mt (6.6 t) weight works well in applications that require heavy lifting. It's bolted directly to the main frame for extra rigidity.

Undercarriage

Durable Cat undercarriage absorbs stress and provides excellent stability. The 336D2/D2 L comes standard with grease lubricated tracks. The track links are assembled and sealed with grease to decrease internal bushing wear, reduce travel noise and extend service life lowering operating costs.

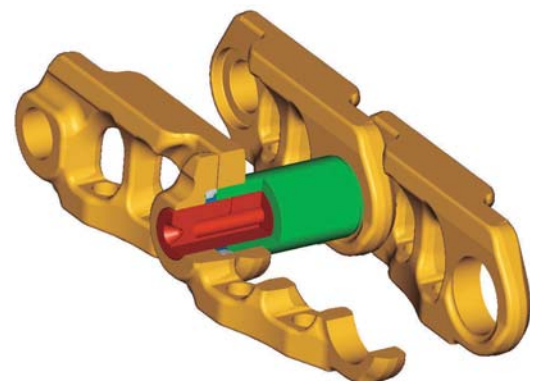



Front Linkage

Made for high stress and long service life

Heavy-Duty Reach Front Linkage

The heavy-duty (HD) reach (R) front linkage is built to work in a variety of tough, demanding applications like loading rock or hammering concrete. The 6.5 m (21'4") heavy duty reach boom is made of high-tensile-strength steel using a large box-section design with interior baffle plates and an additional bottom guard for long life and durability.

Three stick options are available to meet all your application requirements:

- The 3.9 m (12'10") stick is a great choice when you need additional working range like truck loading and deep trenching.
- The 3.2 m (10'6") stick is a versatile option that will meet the needs for most of your construction applications.
- The 2.8 m (9'2") stick is best used when you are working primarily in truck loading applications to maximize your breakout force and increase your bucket fill factor.

Mass Excavation Front Linkage

The mass excavation (ME) front linkage is designed to maximize machine performance through superior digging forces and a larger bucket capacity. The 6.18 m (20'3") mass excavation boom is reinforced with a large cross section and internal baffle plates for long life and durability.

The ME reach boom has two stick options to meet your demanding applications:

- The 2.55 m (8'4") stick is designed for large, high-volume earthmoving work.
- The 2.15 m (7'1") stick is best when you primarily use high-capacity buckets in truck loading applications to maximize your breakout force and increase your bucket fill factor.

Service and Maintenance

Fast, easy and safe access built in

Ground-Level Service

The design and layout of the 336D2/D2 L was made with the service technician in mind. Most service locations are easily accessible at ground level to allow service and maintenance to get completed quickly and efficiently.

Air Filter Compartment

The air filter features a double-element construction for superior cleaning efficiency. When the air filter plugs, a warning is displayed on the cab monitor. Maintenance-free batteries are standard along with a battery disconnect switch.

Greasing Points

A concentrated remote greasing block on the boom allows greasing of hard-to-reach locations on the boom and stick.

Fan Guard

The engine radiator fan is enclosed by a steel guard that provides maximum protection when carrying out routine service and maintenance.



Anti-Skid Plating

Anti-skid plating covers the entire upper structure and storage box to prevent slipping during maintenance. Safety is further enhanced with the addition of countersunk bolts to reduce trip hazards.

Diagnostics and Monitoring

Standard hydraulic test ports enable a service technician to evaluate the hydraulic system, engine oil, and coolant quickly and easily for more efficient maintenance.

Pump Compartment

A service door on the right side of the upper structure allows ground-level access to the hydraulic pumps, hydraulic filters, engine oil filter, and fuel filters.

Radiator Compartment

The left rear service door allows easy access to the engine radiator, hydraulic oil cooler, air-to-air aftercooler, and AC condenser. A reserve tank and drain cock are attached to the radiator for ground-level maintenance.



Complete Customer Support

Service you can count on



Product Support

Cat dealers utilize a worldwide computer network to find in-stock parts to minimize machine downtime. You can also save money with our line of remanufactured components.

Machine Selection

Your Cat dealers can provide specific recommendations with detailed comparisons of the Cat machines you are considering before you buy. This ensures you get the right size machine and appropriate work tools to meet all of your application needs.

Maintenance Services

Repair option programs guarantee the cost of repairs up front. Condition monitoring services and diagnostic programs such as scheduled oil sampling, coolant sampling, and technical analysis help you avoid unscheduled repairs.

Customer Support Agreements

Cat dealers offer a variety of product support agreements that can be tailored to meet your specific needs. These plans can cover the entire machine – including attachments – to help protect your investment.

Replacement

Repair, rebuild, or replace? Your Cat dealers can help you evaluate the costs involved so you can make the right choice.

Work Tools

Dig, hammer, rip, and cut with confidence



1



2

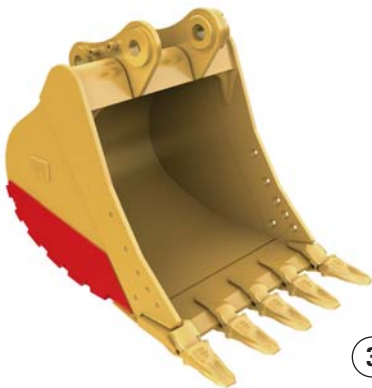

3

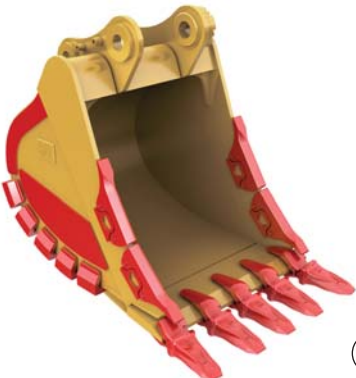

4

Versatility and Performance

Each Cat work tool is designed to optimize the versatility and performance of your machine. An extensive range of buckets, compactors, grapples, multi-processors, rippers, crushers, pulverizers, hammers, and shears is available for your 336D2/D2 L.

Buckets and GET

Cat buckets and Cat Ground Engaging Tools (GET) are designed and matched to the machine to ensure optimal performance and fuel efficiency.

General-Duty Buckets (GD)

GD buckets are for digging in low-impact, moderately abrasive materials such as dirt, loam, gravel, and clay.

Heavy-Duty Buckets (HD)

HD buckets are a good starting point when application conditions vary – especially when conditions include mixed dirt, clay, sand, and gravel.

Severe-Duty Buckets (SD)

SD buckets are best suited to highly abrasive materials like shot rock, sand stone, and granite.

Extreme-Duty Buckets (XD)

XD buckets are for extremely abrasive materials like high-quartzite granite.

- 1) General-Duty Buckets (GD)
- 2) Heavy-Duty Buckets (HD)
- 3) Severe-Duty Buckets (SD)
- 4) Extreme-Duty Buckets (XD)

Couplers

Quick couplers allow one person to change work tools in seconds for maximum performance and flexibility on a job site. One machine can move rapidly from task to task, and a fleet of similarly equipped machines can share a common work tool inventory.

Center-Lock™ Coupler

Center-Lock is a coupler and features a patent-pending locking system. A highly visible secondary lock clearly shows the operator when the coupler is engaged or disengaged from the bucket or work tool.

E Series Hammers

E Series hammers bring together customer expectations for performance, quality, and serviceability along with Caterpillar manufacturing expertise. They are also quiet – a significant benefit in urban and noise-restricted work areas.

Rippers

Constructed from high-strength steels and built to last, Cat rippers endure in the toughest conditions. The box-section structure is reinforced for maximum rigidity, transmitting the full machine power to the material being ripped. Rippers feature a replaceable wear tip, and most models also come equipped with a replaceable shank protector.

Grapples

Cat grapples make Cat excavators the ideal machine for handling loose material, sorting trash, and demolition site cleanup. An array of styles and sizes is available to match excavators to the task at hand.

Multi-Processors

Multi-processors do the work of many types of demolition tools by use of interchangeable jaw sets. Changing jaws allows a single unit to crush, pulverize, and perform a variety of specialized tasks such as cutting steel rebar and tanks.

Shears

Cat shears are designed to take full advantage of the hydraulic flows and pressures produced by Cat excavators – all to enhance productivity without compromising safety or causing premature wear of the shear or carrier.

Pulverizers

Mechanical pulverizers are cost-effective tools for recycling demolished concrete debris. The bucket cylinder on the excavator powers the pulverizer, eliminating the need for a dedicated cylinder, associated hydraulics, and additional installation cost.

Compactors

Cat compactors make job site compaction quick, efficient, and cost effective.

Crushers

The hydraulic concrete crusher is well suited for demolition in residential areas. The tool combines several demolition operations in one piece of equipment:

- Breaking out concrete from fixed structures
- Pulverizing concrete
- Cutting reinforcement rods and small steel profiles



336D2/D2 L Hydraulic Excavator Specifications

Engine

Engine Model	Cat C9 ACERT	
Engine Power (ISO 14396)	209 kW	280 hp
Net Power (SAE J1349/ISO 9249)	201 kW	270 hp
Bore	112 mm	4.41 in
Stroke	149 mm	5.87 in
Displacement	8.8 L	537 in ³

- The Cat C9 meets exhaust emissions equivalent to U.S. EPA Tier 2, EU Stage II, and China Tier 2 emission regulations.
- Net power advertised is the power available at the flywheel when the engine is equipped with fan, air cleaner, muffler, and alternator.
- The field-proven C9 engine can work efficiently at altitudes up to 2300 m (7,546 ft).

Weights

Operating Weight		
Standard Undercarriage*	34 489 kg	76,035 lb
Long Undercarriage**	37 086 kg	81,761 lb

*Standard undercarriage, 2.8 m (9'2") reach stick, 600 mm (24 in) shoes, 6.0 mt (6.6 t) counterweight.

**Long undercarriage, 2.55 m (8'4") mass stick, 800 mm (32 in) shoes, 6.0 mt (6.6 t) counterweight.

Swing Mechanism

Swing Speed	8.98 rpm	
Swing Torque	108.6 kN·m	80,142 lbf·ft

Drive

Gradeability	30°/70%	
Maximum Travel Speed	4.85 km/h	3.0 mph
Maximum Drawbar Pull	300.5 kN	67,555 lbf

Hydraulic System

Main System – Maximum Flow (each)	265 L/min	70 gal
Swing System – Maximum Flow	265 L/min	70 gal
Maximum Pressure – Equipment	35 000 kPa	5,076 psi
Maximum Pressure – Travel	35 000 kPa	5,076 psi
Maximum Pressure – Swing	29 000 kPa	4,061 psi
Pilot System – Maximum Flow	40 L/min	10.6 gal/min
Pilot System – Maximum Pressure	4000 kPa	580.2 psi
Boom Cylinder – Bore	150 mm	5.9 in
Boom Cylinder – Stroke	1440 mm	56.7 in
Stick Cylinder – Bore	170 mm	6.7 in
Stick Cylinder – Stroke	1738 mm	68.4 in
Bucket Cylinder – Bore	150 mm	5.9 in
Bucket Cylinder – Stroke	1151 mm	45.3 in

Service Refill Capacities

Fuel Tank Capacity	620 L	163.79 gal
Cooling System	40 L	10.57 gal
Engine Oil	40 L	10.57 gal
Swing Drive	19 L	5.02 gal
Final Drive (each)	8 L	2.11 gal
Hydraulic System Oil Capacity (including tank)	410 L	108.31 gal
Hydraulic Tank Oil	175 L	46.2 gal

336D2/D2 L Hydraulic Excavator Specifications

Dimensions

All dimensions are approximate.

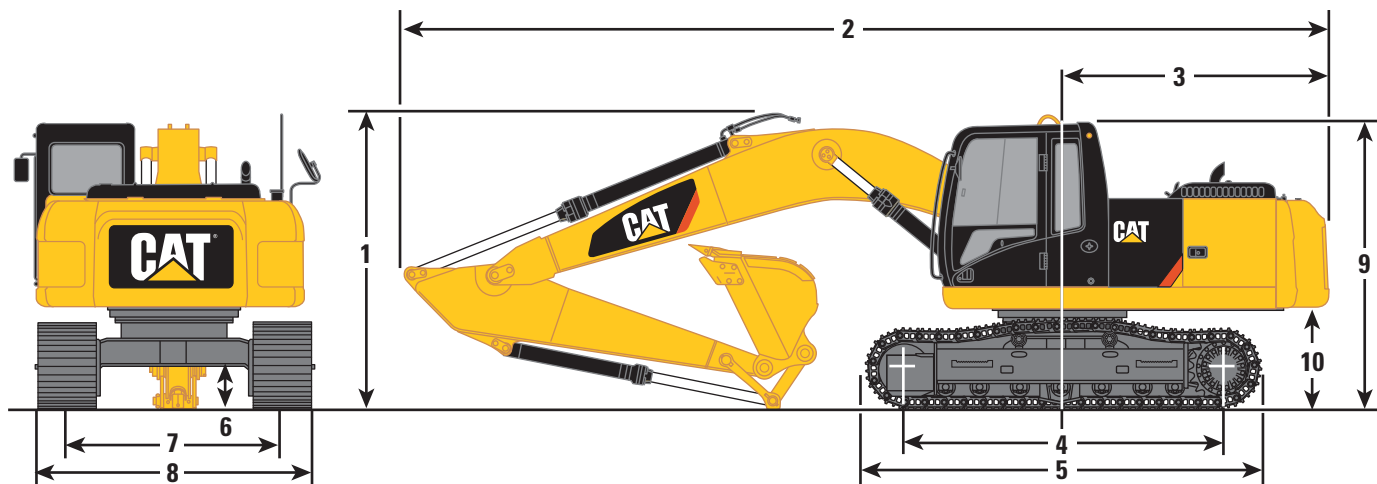

Boom Options	HD Reach Boom 6.50 m (21'4")			Mass Boom 6.18 m (20'3")	
Stick Options	R3.9DB (12'10")	R3.2DB (10'6")	R2.8DB (9'2")	M2.55TB (8'4")	M2.15TB (7'1")
1 Shipping Height*	3700 mm (12'2")	3340 mm (11'0")	3570 mm (11'9")	3650 mm (12'0")	3680 mm (12'1")
2 Shipping Length	11 200 mm (36'9")	11 150 mm (36'7")	11 210 mm (36'9")	10 910 mm (35'10")	11 200 mm (36'9")
3 Tail Swing Radius	3500 mm (11'6")	3500 mm (11'6")	3500 mm (11'6")	3500 mm (11'6")	3500 mm (11'6")
4 Length to Center of Rollers					
Standard Undercarriage	3610 mm (11'10")	3610 mm (11'10")	3610 mm (11'10")	3610 mm (11'10")	3610 mm (11'10")
Long Undercarriage	4040 mm (13'3")	4040 mm (13'3")	4040 mm (13'3")	4040 mm (13'3")	4040 mm (13'3")
5 Track Length					
Standard Undercarriage	4590 mm (15'1")	4590 mm (15'1")	4590 mm (15'1")	4590 mm (15'1")	4590 mm (15'1")
Long Undercarriage	5020 mm (16'6")	5020 mm (16'6")	5020 mm (16'6")	5020 mm (16'6")	5020 mm (16'6")
6 Ground Clearance**	450 mm (1'6")	450 mm (1'6")	450 mm (1'6")	450 mm (1'6")	450 mm (1'6")
7 Track Gauge					
Standard Undercarriage	2590 mm (8'6")	2590 mm (8'6")	2590 mm (8'6")	2590 mm (8'6")	2590 mm (8'6")
Long Undercarriage	2590 mm (8'6")	2590 mm (8'6")	2590 mm (8'6")	2590 mm (8'6")	2590 mm (8'6")
8 Transport Width – Long/Standard Undercarriage					
600 mm (24 in) Shoes	3190 mm (10'6")	3190 mm (10'6")	3190 mm (10'6")	3190 mm (10'6")	3190 mm (10'6")
700 mm (28 in) Shoes	3290 mm (10'10")	3290 mm (10'10")	3290 mm (10'10")	3290 mm (10'10")	3290 mm (10'10")
800 mm (32 in) Shoes	3390 mm (11'2")	3390 mm (11'2")	3390 mm (11'2")	3390 mm (11'2")	3390 mm (11'2")
9 Cab Height*	3140 mm (10'4")	3140 mm (10'4")	3140 mm (10'4")	3140 mm (10'4")	3140 mm (10'4")
10 Counterweight Clearance**	1220 mm (4'0")	1220 mm (4'0")	1220 mm (4'0")	1220 mm (4'0")	1220 mm (4'0")

*Including shoe lug height.

**Without shoe lug height.

336D2/D2 L Hydraulic Excavator Specifications

Working Ranges

All dimensions are approximate.

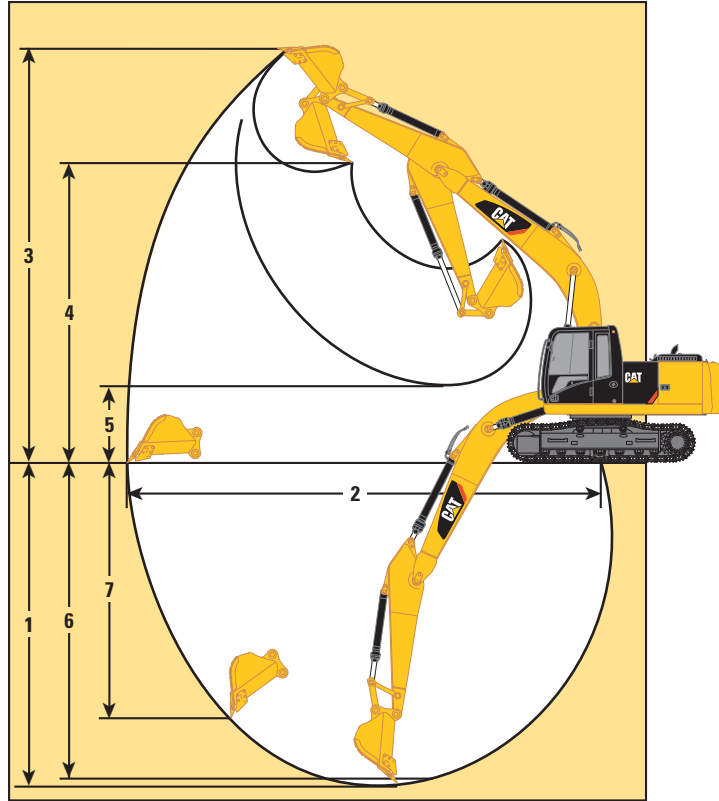

Boom Options	HD Reach Boom 6.50 m (21'4")			Mass Boom 6.18 m (20'3")		
	Stick Options	R3.9DB (12'10")	R3.2DB (10'6")	R2.8DB (9'2")	M2.55TB (8'4")	M2.15TB (7'1")
1 Maximum Digging Depth		8090 mm (26'7")	7390 mm (24'3")	6990 mm (22'11")	6570 mm (21'7")	6170 mm (20'3")
2 Maximum Reach at Ground Level		11 640 mm (38'2")	10 920 mm (35'10")	10 620 mm (34'10")	10 180 mm (33'5")	9760 mm (32'0")
3 Maximum Cutting Height		10 710 mm (35'2")	10 240 mm (33'7")	10 300 mm (33'10")	10 070 mm (33'1")	9740 mm (32'0")
4 Maximum Loading Height		7640 mm (25'1")	7200 mm (23'8")	7200 mm (23'8")	6690 mm (21'11")	6410 mm (21'0")
5 Minimum Loading Height		2010 mm (6'7")	2710 mm (8'11")	3110 mm (10'2")	3000 mm (9'10")	3400 mm (11'2")
6 Maximum Depth Cut for 2440 mm (8'0") Level Bottom		7960 mm (26'1")	7230 mm (23'9")	6820 mm (22'5")	6400 mm (21'0")	5970 mm (19'7")
7 Maximum Vertical Wall Digging Depth		6700 mm (22'0")	5830 mm (19'2")	5770 mm (18'11")	5340 mm (17'6")	4710 mm (15'5")

336D2/D2 L Hydraulic Excavator Specifications

Major Component Weights

Base Machine – 6.0 mt/6.6 t counterweight (with counterweight and without front linkage)	
Standard Undercarriage – 600 mm (24 in) Shoes	26 753 kg (58,980 lb)
Long Undercarriage – 700 mm (28 in) Shoes	27 987 kg (61,701 lb)
Counterweight	
Standard Counterweight	6018 kg (13,267 lb)
Two Boom Cylinders	668 kg (1,473 lb)
Boom (includes lines, pins, and stick cylinder)	
HD Reach Boom – 6.50 m (21'4")	3526 kg (7,773 lb)
Mass Boom – 6.18 m (20'3")	3294 kg (7,262 lb)
Stick (includes lines, pins, linkage, and bucket cylinder)	
R3.9DB (12'10")	2089 kg (4,605 lb)
R3.2DB (10'6")	2015 kg (4,442 lb)
R2.8DB (9'2")	1907 kg (4,204 lb)
M2.55TB (8'4")	2024 kg (4,462 lb)
M2.15TB (7'1")	1949 kg (4,296 lb)
Track Shoe (Standard Undercarriage/per one track)	
600 mm (24 in) Triple Grouser Shoes	1867 kg (4,116 lb)
700 mm (28 in) Triple Grouser Shoes	2016 kg (4,445 lb)
800 mm (32 in) Triple Grouser Shoes	2330 kg (5,137 lb)
Track Shoe (Long Undercarriage/per one track)	
600 mm (24 in) Triple Grouser Shoes	2033 kg (4,482 lb)
700 mm (28 in) Triple Grouser Shoes	2196 kg (4,841 lb)
800 mm (32 in) Triple Grouser Shoes	2538 kg (5,595 lb)

336D2/D2 L Hydraulic Excavator Specifications

Operating Weights and Ground Pressures

336D2 – Standard Undercarriage – Counterweight 6.0 mt (6.6 t)						
	600 mm (24 in) Triple Grouser Shoes		700 mm (28 in) Triple Grouser Shoes		800 mm (32 in) Triple Grouser Shoes	
HD Reach Boom – 6.50 m (21'4")						
R3.9DB (12'10")	34 671 kg (76,436 lb)	71.7 kPa (10.4 psi)	34 969 kg (77,093 lb)	62.0 kPa (8.99 psi)	35 597 kg (78,478 lb)	55.2 kPa (8.01 psi)
R3.2DB (10'6")	34 597 kg (76,273 lb)	71.5 kPa (10.37 psi)	34 895 kg (76,930 lb)	61.9 kPa (8.98 psi)	35 523 kg (78,315 lb)	55.1 kPa (8.0 psi)
R2.8DB (9'2")	34 489 kg (76,035 lb)	71.3 kPa (10.34 psi)	34 787 kg (76,692 lb)	61.7 kPa (8.95 psi)	35 415 kg (78,077 lb)	54.9 kPa (7.96 psi)
Mass Boom – 6.18 m (20'3")						
M2.55TB (8'4")	35 168 kg (77,532 lb)	72.7 kPa (10.54 psi)	35 466 kg (78,189 lb)	62.9 kPa (9.12 psi)	36 094 kg (79,574 lb)	56.0 kPa (8.12 psi)
M2.15TB (7'1")	35 093 kg (77,367 lb)	72.6 kPa (10.53 psi)	35 391 kg (78,024 lb)	62.7 kPa (9.09 psi)	36 019 kg (79,408 lb)	55.9 kPa (8.11 psi)

336D2 L – Long Undercarriage – Counterweight 6.0 mt (6.6 t)						
	600 mm (24 in) Triple Grouser Shoes		700 mm (28 in) Triple Grouser Shoes		800 mm (32 in) Triple Grouser Shoes	
HD Reach Boom – 6.50 m (21'4")						
R3.9DB (12'10")	35 579 kg (78,438 lb)	66.3 kPa (9.62 psi)	35 905 kg (79,157 lb)	57.3 kPa (8.31 psi)	36 589 kg (80,665 lb)	51.1 kPa (7.41 psi)
R3.2DB (10'6")	35 505 kg (78,275 lb)	66.1 kPa (9.59 psi)	35 831 kg (78,994 lb)	57.2 kPa (8.30 psi)	36 515 kg (80,502 lb)	51.0 kPa (7.40 psi)
R2.8DB (9'2")	35 397 kg (78,037 lb)	65.9 kPa (9.56 psi)	35 723 kg (78,756 lb)	57.0 kPa (8.27 psi)	36 407 kg (80,264 lb)	50.9 kPa (7.38 psi)
Mass Boom – 6.18 m (20'3")						
M2.55TB (8'4")	36 076 kg (79,534 lb)	67.2 kPa (9.75 psi)	36 402 kg (80,253 lb)	58.1 kPa (8.43 psi)	37 086 kg (81,761 lb)	51.8 kPa (7.51 psi)
M2.15TB (7'1")	36 001 kg (79,369 lb)	67.1 kPa (9.73 psi)	36 327 kg (80,087 lb)	58.0 kPa (8.41 psi)	37 011 kg (81,595 lb)	51.7 kPa (7.50 psi)

Bucket and Stick Digging Forces

	HD Reach Boom – 6.50 m (21'4")			Mass Boom – 6.18 m (20'3")	
	R3.9DB (12'10")	R3.2DB (10'6")	R2.8DB (9'2")	M2.55TB (8'4")	M2.15TB (7'1")
Heavy-Duty Bucket					
Bucket Digging Force (ISO)	211 kN (47,460 lbf)	211 kN (47,460 lbf)	211 kN (47,460 lbf)	265 kN (59,570 lbf)	265 kN (59,570 lbf)
Bucket Digging Force (SAE)	185 kN (41,440 lbf)	185 kN (41,440 lbf)	185 kN (41,440 lbf)	229 kN (51,410 lbf)	229 kN (51,410 lbf)
Stick Digging Force (ISO)	145 kN (32,600 lbf)	167 kN (37,520 lbf)	186 kN (41,760 lbf)	191 kN (42,880 lbf)	222 kN (49,950 lbf)
Stick Digging Force (SAE)	141 kN (31,700 lbf)	162 kN (36,360 lbf)	179 kN (40,320 lbf)	183 kN (41,130 lbf)	212 kN (47,630 lbf)

336D2/D2 L Hydraulic Excavator Specifications

HD Reach Boom Lift Capacities – Standard Undercarriage – Counterweight: 6.0 mt (6.6 t)

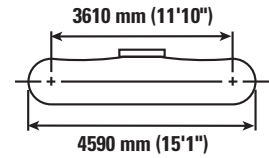
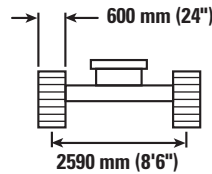
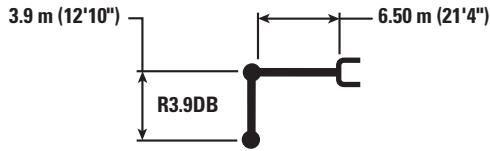

		1500 mm/60 in		3000 mm/120 in		4500 mm/180 in		6000 mm/240 in		7500 mm/300 in		9000 mm/360 in		mm in		
9000 mm 360 in	kg lb													*5850 *13,000	*5850 *13,000	7370 290
7500 mm 300 in	kg lb									*7100 *15,700	7050 15,100			*5400 *11,950	*5400 *11,950	8560 340
6000 mm 240 in	kg lb									*7400 *16,150	6900 14,850	6800 *13,800	5000 10,650	*5250 *11,550	4650 10,300	9360 370
4500 mm 180 in	kg lb							*9050 *19,550	*9050 *19,550	*8050 *17,550	6650 14,250	6700 14,350	4900 10,450	*5250 *11,550	4150 9,100	9860 390
3000 mm 120 in	kg lb					*14 150 *30,400	13 600 29,350	*10 700 *23,100	8800 19,000	8650 18,650	6300 13,550	6500 13,950	4700 10,100	5350 11,800	3850 8,450	10 120 400
1500 mm 60 in	kg lb					*17 050 *36,700	12 400 26,650	11 600 25,000	8200 17,700	8300 17,850	5950 12,800	6300 13,500	4500 9,700	5250 11,500	3750 8,200	10 150 400
0 mm 0 in	kg lb			*7850 *17,850	*7850 *17,850	17 550 37,600	11 700 25,200	11 150 23,950	7750 16,700	8000 17,200	5700 12,200	6150 13,200	4350 9,400	5300 11,650	3750 8,300	9950 400
-1500 mm -60 in	kg lb	*8200 *18,300	*8200 *18,300	*12 400 *27,950	*12 400 *27,950	17 250 36,950	11 450 24,600	10 850 23,350	7550 16,200	7850 16,850	5500 11,850	6050 13,000	4300 9,200	5600 12,400	4000 8,750	9510 380
-3000 mm -120 in	kg lb	*13 150 *29,400	*13 150 *29,400	*18 150 *41,050	*18 150 *41,050	17 250 37,000	11 450 24,650	10 800 23,250	7500 16,100	7800 16,800	5500 11,800			6300 13,900	4450 9,850	8790 350
-4500 mm -180 in	kg lb	*18 950 *42,600	*18 950 *42,600	*22 150 *47,750	*22 150 *47,750	*15 950 *34,400	11 700 25,150	10 950 23,600	7600 16,450	7950 17,200	5650 12,200			7700 17,150	5450 12,150	7710 310
-6000 mm -240 in	kg lb					*12 100 *25,500	*12 100 *25,500	*8550	8050					*8350 *18,200	7900 18,000	6090 240



ISO 10567



*Indicates that the load is limited by hydraulic lifting capacity rather than tipping load. The above loads are in compliance with hydraulic excavator lift capacity standard ISO 10567:2007. They do not exceed 87% of hydraulic lifting capacity or 75% of tipping load. Weight of all lifting accessories must be deducted from the above lifting capacities. Lifting capacities are based on the machine standing on a firm, uniform supporting surface. The use of a work tool attachment point to handle/lift objects, could affect the machine lift performance.

Lift capacity stays with ±5% for all available track shoes.

Always refer to the appropriate Operation and Maintenance Manual for specific product information.

336D2/D2 L Hydraulic Excavator Specifications

HD Reach Boom Lift Capacities – Standard Undercarriage – Counterweight: 6.0 mt (6.6 t)

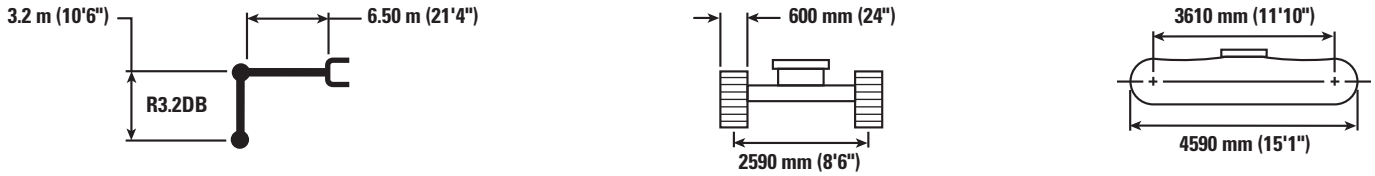

		3000 mm/120 in		4500 mm/180 in		6000 mm/240 in		7500 mm/300 in		9000 mm/360 in		mm in		
7500 mm 300 in	kg lb							*7750 6800				*6700 *14,800	6450 14,550	7710 300
6000 mm 240 in	kg lb							*7850 *17,200	6750 14,450			*6500 *14,300	5300 11,750	8580 340
4500 mm 180 in	kg lb			*12 050 *32,650	*12 050 28,200	*9650 *20,850	9200 19,850	*8450 *18,350	6500 13,950	6550 14,500	4750 10,600	6400 14,150	4650 10,250	9130 360
3000 mm 120 in	kg lb			*15 200 *32,650	13 050 28,200	*11 150 *24,100	8600 18,550	8550 18,400	6200 13,300	6450 13,800	4650 9,950	6000 13,200	4300 9,500	9410 370
1500 mm 60 in	kg lb			*17 500 *37,700	12 050 26,000	11 500 24,700	8050 17,400	8250 17,700	5900 12,650	6250 13,500	4500 9,650	5850 12,850	4150 9,150	9440 380
0 mm 0 in	kg lb			17 500 37,500	11 650 25,050	11 100 23,850	7750 16,650	8000 17,200	5650 12,200	6150 13,250	4400 9,400	5950 13,100	4250 9,300	9220 370
-1500 mm -60 in	kg lb	*13 250 *29,900	*13 250 *29,900	17 400 37,300	11 550 24,850	10 950 23,550	7600 16,300	7900 17,000	5550 12,000			6400 14,100	4550 10,000	8750 350
-3000 mm -120 in	kg lb	*20 900 *47,350	*20 900 *47,350	*16 550 *35,800	11 700 25,150	11 000 23,600	7600 16,400	7950 17,150	5600 12,100			7350 16,300	5200 11,550	7960 320
-4500 mm -180 in	kg lb	*18 550 *39,900	*18 550 *39,900	*13 950 *30,000	12 050 25,900	*10 550 *22,450	7850 16,950					*8900 *19,550	6750 15,050	6750 270



ISO 10567



*Indicates that the load is limited by hydraulic lifting capacity rather than tipping load. The above loads are in compliance with hydraulic excavator lift capacity standard ISO 10567:2007. They do not exceed 87% of hydraulic lifting capacity or 75% of tipping load. Weight of all lifting accessories must be deducted from the above lifting capacities. Lifting capacities are based on the machine standing on a firm, uniform supporting surface. The use of a work tool attachment point to handle/lift objects, could affect the machine lift performance.

Lift capacity stays with ±5% for all available track shoes.

Always refer to the appropriate Operation and Maintenance Manual for specific product information.

336D2/D2 L Hydraulic Excavator Specifications

HD Reach Boom Lift Capacities – Standard Undercarriage – Counterweight: 6.0 mt (6.6 t)

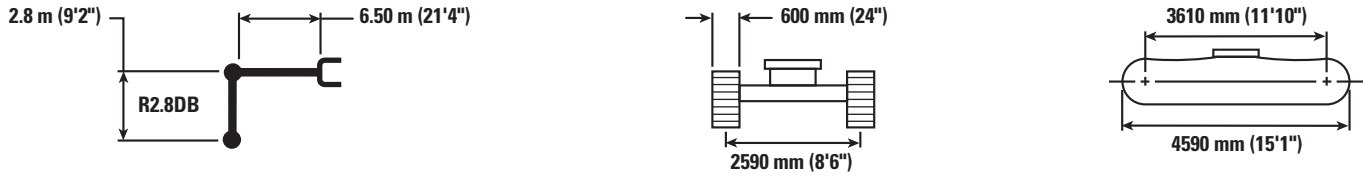

		3000 mm/120 in		4500 mm/180 in		6000 mm/240 in		7500 mm/300 in		9000 mm/360 in		mm in		
7500 mm 300 in	kg lb											*8400 *18,550	6950 15,650	7340 290
6000 mm 240 in	kg lb					*9000 *19,500	*9000 *19,500	*8350 *18,250	6650 14,300			7700 17,100	5600 12,500	8250 330
4500 mm 180 in	kg lb			*13 000 *27,850	*13 000 *27,850	*10 200 *22,050	9100 19,650	8850 19,000	6450 13,850			6750 14,950	4900 10,850	8820 350
3000 mm 120 in	kg lb			*16 100 *34,600	12 800 27,700	*11 650 *25,150	8550 18,400	8550 18,350	6150 13,250	6400	4650	6300 13,900	4550 10,000	9110 360
1500 mm 60 in	kg lb			*15 900 *38,350	12 000 25,800	11 450 24,650	8050 17,350	8250 17,750	5900 12,700	6300	4500	6150 13,550	4400 9,700	9140 360
0 mm 0 in	kg lb			17 550 37,600	11 700 25,150	11 150 23,950	7750 16,700	8050 17,300	5700 12,300			6300 13,850	4500 9,900	8920 350
-1500 mm -60 in	kg lb	*12 350 *28,100	*12 350 *28,100	17 550 37,600	11 700 25,150	11 050 23,700	7650 16,500	8000 17,150	5650 12,150			6800 15,050	4850 10,700	8420 340
-3000 mm -120 in	kg lb	*21 050 *45,750	*21 050 *45,750	*16 000 *34,700	11 850 25,500	11 100 23,900	7750 16,700	8100	5750			7950 17,650	5650 12,550	7600 300
-4500 mm -180 in	kg lb	*16 750 *35,950	*16 750 *35,950	*13 000 *27,850	12 250 26,400	*9650 *20,250	8050 17,450					*8800 *19,350	7550 16,950	6330 250



ISO 10567



*Indicates that the load is limited by hydraulic lifting capacity rather than tipping load. The above loads are in compliance with hydraulic excavator lift capacity standard ISO 10567:2007. They do not exceed 87% of hydraulic lifting capacity or 75% of tipping load. Weight of all lifting accessories must be deducted from the above lifting capacities. Lifting capacities are based on the machine standing on a firm, uniform supporting surface. The use of a work tool attachment point to handle/lift objects, could affect the machine lift performance.









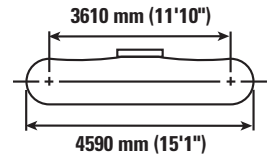
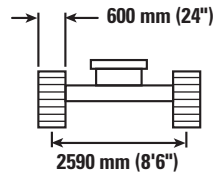
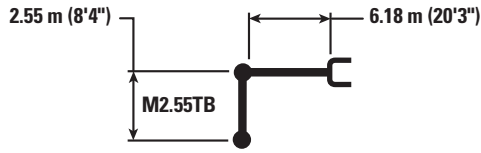

Lift capacity stays with ±5% for all available track shoes.

Always refer to the appropriate Operation and Maintenance Manual for specific product information.

336D2/D2 L Hydraulic Excavator Specifications

Mass Boom Lift Capacities – Standard Undercarriage – Counterweight: 6.0 mt (6.6 t)



		3000 mm/120 in		4500 mm/180 in		6000 mm/240 in		7500 mm/300 in				mm in
												
7500 mm 300 in	kg lb					*9250 *20,450	*9250 *20,450			*8300 *18,400	8200 *18,400	6590 260
6000 mm 240 in	kg lb					*9600 *20,850	9500 20,450	8900	6500	*7900 *17,450	6350 14,200	7600 300
4500 mm 180 in	kg lb			*13 400 *28,750	*13 400 *28,750	*10 650 *23,050	9050 19,500	8750 18,750	6350 13,650	7500 16,650	5450 12,100	8210 330
3000 mm 120 in	kg lb			*16 350 *35,150	12 850 27,700	11 950 25,650	8500 18,300	8450 18,200	6100 13,150	6950 15,300	5000 11,050	8520 340
1500 mm 60 in	kg lb			17 900 38,450	12 000 25,900	11 450 24,600	8050 17,300	8200 17,650	5850 12,650	6750 14,900	4850 10,700	8550 340
0 mm 0 in	kg lb			17 600 37,700	11 750 25,250	11 150 23,950	7750 16,750	8050 17,300	5700 12,300	6950 15,350	5000 10,950	8310 330
-1500 mm -60 in	kg lb	*16 900 *38,350	*16 900 *38,350	*17 450 37,700	11 750 25,300	11 050 23,800	7700 16,600	8050 17,300	5700 12,300	7650 16,900	5450 12,000	7780 310
-3000 mm -120 in	kg lb	*19 950 *43,300	*19 950 *43,300	*15 350 *33,200	12 000 25,750	11 200 24,150	7850 16,900			9250 20,550	6550 14,550	6880 270
-4500 mm -180 in	kg lb			*11 250 *23,800	*11 250 *23,800					*8900 *19,450	*8900 *19,450	5430 210



ISO 10567



*Indicates that the load is limited by hydraulic lifting capacity rather than tipping load. The above loads are in compliance with hydraulic excavator lift capacity standard ISO 10567:2007. They do not exceed 87% of hydraulic lifting capacity or 75% of tipping load. Weight of all lifting accessories must be deducted from the above lifting capacities. Lifting capacities are based on the machine standing on a firm, uniform supporting surface. The use of a work tool attachment point to handle/lift objects, could affect the machine lift performance.









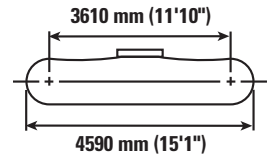
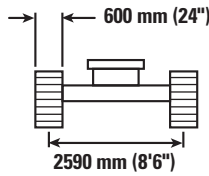
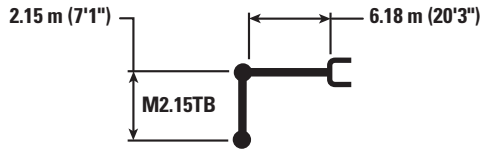

Lift capacity stays with ±5% for all available track shoes.

Always refer to the appropriate Operation and Maintenance Manual for specific product information.

336D2/D2 L Hydraulic Excavator Specifications

Mass Boom Lift Capacities – Standard Undercarriage – Counterweight: 6.0 mt (6.6 t)



		3000 mm/120 in		4500 mm/180 in		6000 mm/240 in		7500 mm/300 in				
												mm in
7500 mm 300 in	kg lb					*10 050 22,150	9550 20,200			*10 050 22,300	9450 21,500	6030 240
6000 mm 240 in	kg lb					*10 150 22,150	9400 20,200			9650 21,350	7050 15,750	7120 280
4500 mm 180 in	kg lb			*14 250 30,650	13 850 29,850	*11 150 24,150	8950 19,300	8700 18,650	6300 13,550	8200 18,150	5950 13,200	7780 310
3000 mm 120 in	kg lb			*36,850	27,150	11 850 25,500	8400 18,150	8450 18,200	6100 13,100	7500 16,550	5450 11,950	8100 320
1500 mm 60 in	kg lb					11 400 24,500	8000 17,250	8200 17,700	5900 12,650	7300 16,100	5250 11,550	8140 320
0 mm 0 in	kg lb			17 600 37,750	11 800 25,300	11 150 24,000	7800 16,800	8100 17,450	5750 12,450	7550 16,650	5400 11,900	7890 310
-1500 mm -60 in	kg lb	*17 800 40,750	*17 800 40,750	*16 950 36,750	11 850 25,500	11 150 23,950	7800 16,750			8400 18,600	6000 13,200	7320 290
-3000 mm -120 in	kg lb	*17 950 39,050	*17 950 39,050	*14 500 31,350	12 150 26,100	*11 050 23,550	8000 17,250			*10 100 22,250	7450 16,500	6360 250



ISO 10567



*Indicates that the load is limited by hydraulic lifting capacity rather than tipping load. The above loads are in compliance with hydraulic excavator lift capacity standard ISO 10567:2007. They do not exceed 87% of hydraulic lifting capacity or 75% of tipping load. Weight of all lifting accessories must be deducted from the above lifting capacities. Lifting capacities are based on the machine standing on a firm, uniform supporting surface. The use of a work tool attachment point to handle/lift objects, could affect the machine lift performance.

Lift capacity stays with $\pm 5\%$ for all available track shoes.

Always refer to the appropriate Operation and Maintenance Manual for specific product information.

336D2/D2 L Hydraulic Excavator Specifications

HD Reach Boom Lift Capacities – Long Undercarriage – Counterweight: 6.0 mt (6.6 t)

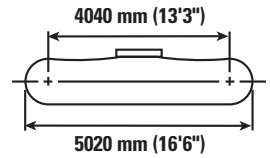
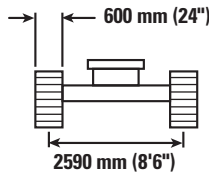
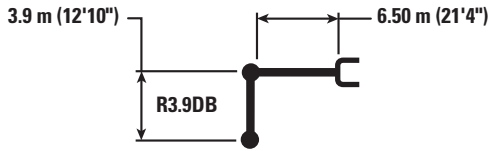

		1500 mm/60 in		3000 mm/120 in		4500 mm/180 in		6000 mm/240 in		7500 mm/300 in		9000 mm/360 in		mm in		
9000 mm	kg													*5850	*5850	7370
360 in	lb													*13,000	*13,000	290
7500 mm	kg									*7100	*7100			*5400	*5400	8560
300 in	lb									*15,700	15,400			*11,950	*11,950	340
6000 mm	kg									*7400	7050	*7100	5100	*5250	4750	9360
240 in	lb									*16,150	15,150	*13,800	10,900	*11,550	10,550	370
4500 mm	kg							*9050	*9050	*8050	6800	*7500	5000	*5250	4250	9860
180 in	lb							*19,550	*19,550	*17,550	14,600	*16,450	10,700	*11,550	9,350	390
3000 mm	kg					*14 150	13 900	*10 700	9000	*8950	6450	7650	4800	*5400	3950	10 120
120 in	lb					*30,400	29,950	*23,100	19,450	*19,450	13,850	16,450	10,350	*11,850	8,700	400
1500 mm	kg					*17 050	12 650	*12 250	8400	9850	6100	7450	4650	*5700	3850	10 150
60 in	lb					*36,700	27,300	*26,500	18,100	21,150	13,100	16,000	9,950	*12,550	8,450	400
0 mm	kg			*7850	*7850	*18 550	12 000	*13 350	7950	9550	5800	7300	4500	*6200	3850	9950
0 in	lb			*17,850	*17,850	*40,100	25,800	28,850	17,150	20,550	12,550	15,650	9,650	*13,650	8,500	400
-1500 mm	kg	*8200	*8200	*12 400	*12 400	*18 750	11 750	13 150	7750	9350	5650	7200	4400	6700	4100	9510
-60 in	lb	*18,300	*18,300	*27,950	*27,950	*40,600	25,250	28,250	16,600	20,150	12,200	15,500	9,450	14,700	9,000	380
-3000 mm	kg	*13 150	*13 150	*18 150	*18 150	*17 950	11 750	13 100	7700	9350	5650			7500	4600	8790
-120 in	lb	*29,400	*29,400	*41,050	*41,050	*38,800	25,250	28,100	16,500	20,100	12,150			16,550	10,150	350
-4500 mm	kg	*18 950	*18 950	*22 150	*22 150	*15 950	12 000	*12 100	7800	*9050	5800			*8600	5600	7710
-180 in	lb	*42,600	*42,600	*47,750	*47,750	*34,400	25,800	*25,950	16,850	*19,050	12,500			*18,950	12,450	310
-6000 mm	kg					*12 100	*12 100	*8550	8250					*8350	8100	6090
-240 in	lb					*25,500	*25,500	*18,500	18,200					*18,200	*18,200	240



ISO 10567



*Indicates that the load is limited by hydraulic lifting capacity rather than tipping load. The above loads are in compliance with hydraulic excavator lift capacity standard ISO 10567:2007. They do not exceed 87% of hydraulic lifting capacity or 75% of tipping load. Weight of all lifting accessories must be deducted from the above lifting capacities. Lifting capacities are based on the machine standing on a firm, uniform supporting surface. The use of a work tool attachment point to handle/lift objects, could affect the machine lift performance.

Lift capacity stays with ±5% for all available track shoes.

Always refer to the appropriate Operation and Maintenance Manual for specific product information.

336D2/D2 L Hydraulic Excavator Specifications

HD Reach Boom Lift Capacities – Long Undercarriage – Counterweight: 6.0 mt (6.6 t)

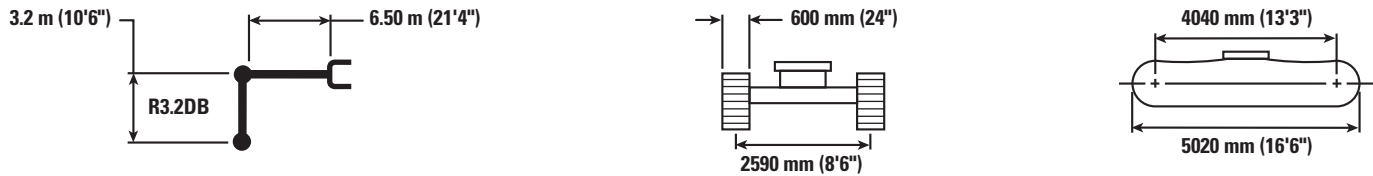

		3000 mm/120 in		4500 mm/180 in		6000 mm/240 in		7500 mm/300 in		9000 mm/360 in		mm in		
7500 mm 300 in	kg lb							*7750 6950				*6700 *14,800	6600 *14,800	7710 300
6000 mm 240 in	kg lb							*7850 *17,200	6900 14,800			*6500 *14,300	5450 12,050	8580 340
4500 mm 180 in	kg lb			*12 050 12 050	*12 050 12 050	*9650 *20,850	9450 20,300	*8450 *18,350	6650 14,300	*7700 4900		*6550 *14,350	4750 10,550	9130 360
3000 mm 120 in	kg lb			*15 200 *32,650	13 400 28,900	*11 150 *24,100	8800 19,000	*9200 *19,950	6350 13,600	7600 16,300	4750 10,200	*6800 *14,900	4400 9,750	9410 370
1500 mm 60 in	kg lb			*17 500 *37,700	12 400 26,700	*12 450 *26,950	8300 17,850	9800 21,100	6050 13,000	7450 16,000	4600 9,900	6950 15,250	4300 9,450	9440 380
0 mm 0 in	kg lb			*18 250 *39,500	11 950 25,700	*13 250 *28,650	7950 17,100	9550 20,550	5800 12,550	7350 15,750	4500 9,700	7100 15,600	4350 9,600	9220 370
-1500 mm -60 in	kg lb	*13 250 *29,900	*13 250 *29,900	*17 850 *38,700	11 850 25,500	13 250 28,450	7800 16,750	9450 20,350	5700 12,300			7600 16,800	4650 10,300	8750 350
-3000 mm -120 in	kg lb	*20 900 *47,350	*20 900 *47,350	*16 550 *35,800	12 000 25,800	*12 600 *27,150	7800 16,850	9500 20,500	5750 12,450			8750 19,400	5350 11,850	7960 320
-4500 mm -180 in	kg lb	*18 550 *39,900	*18 550 *39,900	*13 950 *30,000	12 350 26,550	*10 550 *22,450	8050 17,400					*8900 *19,550	6900 15,450	6750 270



ISO 10567



*Indicates that the load is limited by hydraulic lifting capacity rather than tipping load. The above loads are in compliance with hydraulic excavator lift capacity standard ISO 10567:2007. They do not exceed 87% of hydraulic lifting capacity or 75% of tipping load. Weight of all lifting accessories must be deducted from the above lifting capacities. Lifting capacities are based on the machine standing on a firm, uniform supporting surface. The use of a work tool attachment point to handle/lift objects, could affect the machine lift performance.

Lift capacity stays with ±5% for all available track shoes.

Always refer to the appropriate Operation and Maintenance Manual for specific product information.

336D2/D2 L Hydraulic Excavator Specifications

HD Reach Boom Lift Capacities – Long Undercarriage – Counterweight: 6.0 mt (6.6 t)

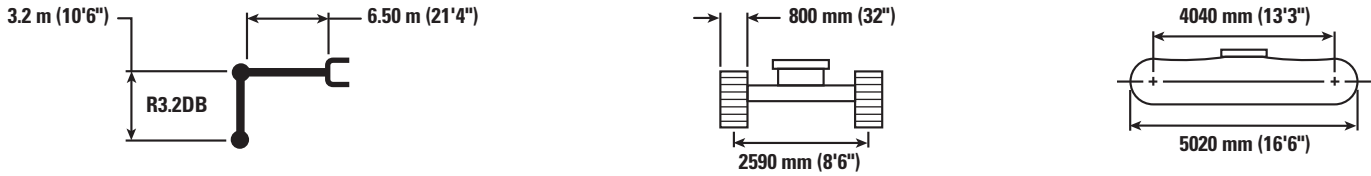

		3000 mm/120 in		4500 mm/180 in		6000 mm/240 in		7500 mm/300 in		9000 mm/360 in		mm in		
7500 mm 300 in	kg lb							*7750 17,200	7150 15,150			*6700 *14,800	*6700 *14,800	7710 300
6000 mm 240 in	kg lb							*7850 *17,200	7050 15,150			*6500 *14,300	5550 12,400	8580 340
4500 mm 180 in	kg lb			*12 050	*12 050	*9650 *20,850	*9650 20,800	*8450 *18,350	6800 14,650	*7700	5050	*6550 *14,350	4900 10,850	9130 360
3000 mm 120 in	kg lb			*15 200 *32,650	13 700 29,600	*11 150 *24,100	9050 19,500	*9200 *19,950	6500 14,000	7800 16,800	4900 10,500	*6800 *14,900	4550 10,050	9410 370
1500 mm 60 in	kg lb			*17 500 *37,700	12 700 27,400	*12 450 *26,950	8500 18,350	*9950 *21,550	6200 13,350	7650 16,450	4750 10,200	7150 15,700	4400 9,700	9440 380
0 mm 0 in	kg lb			*18 250 *39,500	12 300 26,450	*13 250 *28,650	8150 17,600	9850 21,150	6000 12,900	7550 16,250	4650 10,000	7300 16,050	4500 9,900	9220 370
-1500 mm -60 in	kg lb	*13 250 *29,900	*13 250 *29,900	*17 850 *38,700	12 200 26,250	*13 300 *28,800	8000 17,250	9750 20,950	5900 12,700			7850 17,300	4800 10,600	8750 350
-3000 mm -120 in	kg lb	*20 900 *47,350	*20 900 *47,350	*16 550 *35,800	12 350 26,500	*12 600 *27,150	8050 17,350	*9700 *20,800	5950 12,800			*8850 *19,550	5500 12,200	7960 320
-4500 mm -180 in	kg lb	*18 550 *39,900	*18 550 *39,900	*13 950 *30,000	12 650 27,250	*10 550 *22,450	8300 17,900					*8900 *19,550	7100 15,900	6750 270



ISO 10567



*Indicates that the load is limited by hydraulic lifting capacity rather than tipping load. The above loads are in compliance with hydraulic excavator lift capacity standard ISO 10567:2007. They do not exceed 87% of hydraulic lifting capacity or 75% of tipping load. Weight of all lifting accessories must be deducted from the above lifting capacities. Lifting capacities are based on the machine standing on a firm, uniform supporting surface. The use of a work tool attachment point to handle/lift objects, could affect the machine lift performance.

Lift capacity stays with ±5% for all available track shoes.

Always refer to the appropriate Operation and Maintenance Manual for specific product information.

336D2/D2 L Hydraulic Excavator Specifications

HD Reach Boom Lift Capacities – Long Undercarriage – Counterweight: 6.0 mt (6.6 t)

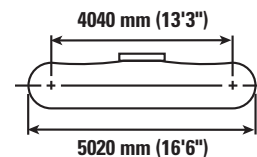
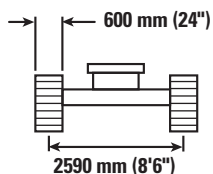
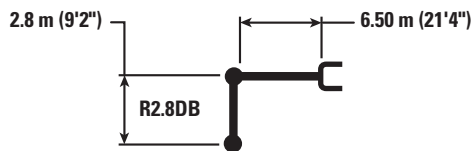

		3000 mm/120 in		4500 mm/180 in		6000 mm/240 in		7500 mm/300 in		9000 mm/360 in		mm in		
7500 mm 300 in	kg lb											*8400 *18,550	7100 16,000	7340 290
6000 mm 240 in	kg lb					*9000 *19,500	*9000 *19,500	*8350 *18,250	6800 14,650			*8150 *18,000	5750 12,800	8250 330
4500 mm 180 in	kg lb			*13 000 *27,850	*13 000 *27,850	*10 200 *22,050	9300 20,100	*8850 *19,200	6600 14,200			8000 17,650	5050 11,150	8820 350
3000 mm 120 in	kg lb			*16 100 *34,600	13 150 28,350	*11 650 *25,150	8750 18,850	*9550 *20,700	6300 13,600	7600	4750	7450 16,400	4650 10,300	9110 360
1500 mm 60 in	kg lb			*15 900 *38,700	12 300 26,450	*12 850 *27,750	8250 17,800	9800 21,100	6050 13,000	7450	4650	7300 16,050	4550 9,950	9140 360
0 mm 0 in	kg lb			*18 300 *39,700	12 000 25,800	*13 450 *28,900	7950 17,150	9600 20,650	5850 12,600			7500 16,500	4650 10,200	8920 350
-1500 mm -60 in	kg lb	*12 350 *28,100	*12 350 *28,100	*17 650 *38,250	12 000 25,800	*13 300 *28,650	7850 16,950	9550 20,500	5800 12,500			8100 17,900	5000 11,000	8420 340
-3000 mm -120 in	kg lb	*21 050 *45,750	*21 050 *45,750	*16 000 *34,700	12 200 26,200	*12 300 *26,550	7950 17,150	*9300 20,500	5900			*9050 *19,950	5800 12,900	7600 300
-4500 mm -180 in	kg lb	*16 750 *35,950	*16 750 *35,950	*13 000 *27,850	12 550 27,050	*9650 *20,250	8250 17,900					*8800 *19,350	7750 17,350	6330 250



ISO 10567



*Indicates that the load is limited by hydraulic lifting capacity rather than tipping load. The above loads are in compliance with hydraulic excavator lift capacity standard ISO 10567:2007. They do not exceed 87% of hydraulic lifting capacity or 75% of tipping load. Weight of all lifting accessories must be deducted from the above lifting capacities. Lifting capacities are based on the machine standing on a firm, uniform supporting surface. The use of a work tool attachment point to handle/lift objects, could affect the machine lift performance.









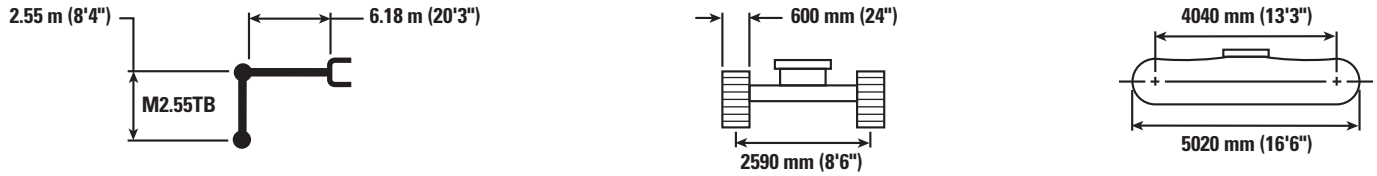

Lift capacity stays with ±5% for all available track shoes.

Always refer to the appropriate Operation and Maintenance Manual for specific product information.

336D2/D2 L Hydraulic Excavator Specifications

Mass Boom Lift Capacities – Long Undercarriage – Counterweight: 6.0 mt (6.6 t)



		3000 mm/120 in		4500 mm/180 in		6000 mm/240 in		7500 mm/300 in				mm in
												
7500 mm 300 in	kg lb					*9250 *20,450	*9250 *20,450			*8300 *18,400	*8300 *18,400	6590 260
6000 mm 240 in	kg lb					*9600 *20,850	*9600 *20,850	*9050	6650	*7900 *17,450	6550 14,550	7600 300
4500 mm 180 in	kg lb			*13 400 *28,750	*13 400 *28,750	*10 650 *23,050	9250 19,900	*9300 *20,300	6500 14,000	*7900 *17,400	5600 12,400	8210 330
3000 mm 120 in	kg lb			*16 350 *35,150	13 150 28,350	*11 950 *25,900	8700 18,750	*9900 *21,500	6250 13,500	*8200 *18,050	5150 11,350	8520 340
1500 mm 60 in	kg lb			*18 200 *39,250	12 350 26,550	*13 050 *28,250	8250 17,750	9750 21,000	6050 12,950	8050 17,700	5000 11,000	8550 340
0 mm 0 in	kg lb			*18 350 *39,800	12 050 25,950	13 450 28,900	8000 17,200	9600 20,650	5850 12,650	8300 18,250	5100 11,250	8310 330
-1500 mm -60 in	kg lb	*16 900 *38,350	*16 900 *38,350	*17 450 *37,800	12 050 25,950	*13 200 *28,550	7900 17,050	9600 20,650	5850 12,650	9100 20,100	5600 12,350	7780 310
-3000 mm -120 in	kg lb	*19 950 *43,300	*19 950 *43,300	*15 350 *33,200	12 300 26,400	*11 700 *25,100	8050 17,350			*9650 *21,200	6750 14,950	6880 270
-4500 mm -180 in	kg lb			*11 250 *23,800	*11 250 *23,800					*8900 *19,450	*8900 *19,450	5430 210



ISO 10567



*Indicates that the load is limited by hydraulic lifting capacity rather than tipping load. The above loads are in compliance with hydraulic excavator lift capacity standard ISO 10567:2007. They do not exceed 87% of hydraulic lifting capacity or 75% of tipping load. Weight of all lifting accessories must be deducted from the above lifting capacities. Lifting capacities are based on the machine standing on a firm, uniform supporting surface. The use of a work tool attachment point to handle/lift objects, could affect the machine lift performance.









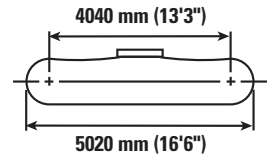
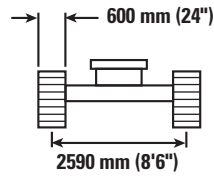
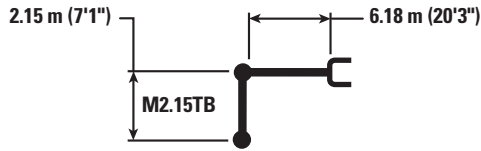

Lift capacity stays with ±5% for all available track shoes.

Always refer to the appropriate Operation and Maintenance Manual for specific product information.

336D2/D2 L Hydraulic Excavator Specifications

Mass Boom Lift Capacities – Long Undercarriage – Counterweight: 6.0 mt (6.6 t)



		3000 mm/120 in		4500 mm/180 in		6000 mm/240 in		7500 mm/300 in				
												mm in
7500 mm 300 in	kg lb					*10 050 *22,150	9750 20,650			*10 050 *22,300	9650 21,950	6030 240
6000 mm 240 in	kg lb					*10 150 *22,150	9600 20,650			*9700 *21,350	7200 16,100	7120 280
4500 mm 180 in	kg lb			*14 250 *30,650	14 150 30,500	*11 150 *24,150	9150 19,750	*9750 *21,300	6500 13,900	*9600 *21,150	6100 13,500	7780 310
3000 mm 120 in	kg lb			*36,850	27,800	*12 400 *26,800	8650 18,600	10 000 21,550	6250 13,450	8900 19,600	5550 12,250	8100 320
1500 mm 60 in	kg lb					*13 350 *28,850	8200 17,700	9800 21,050	6050 13,000	8700 19,100	5400 11,850	8140 320
0 mm 0 in	kg lb			*18 150 *39,450	12 100 26,000	13 450 28,900	8000 17,200	9650 20,800	5900 12,750	9000 19,800	5550 12,200	7890 310
-1500 mm -60 in	kg lb	*17 800 *40,750	*17 800 *40,750	*16 950 *36,750	12 150 26,150	*13 000 *28,100	8000 17,200			10 050 22,150	6150 13,550	7320 290
-3000 mm -120 in	kg lb	*17 950 *39,050	*17 950 *39,050	*14 500 *31,350	12 450 26,750	*11 050 *23,550	8200 17,700			*10 100 *22,250	7600 16,950	6360 250



ISO 10567



*Indicates that the load is limited by hydraulic lifting capacity rather than tipping load. The above loads are in compliance with hydraulic excavator lift capacity standard ISO 10567:2007. They do not exceed 87% of hydraulic lifting capacity or 75% of tipping load. Weight of all lifting accessories must be deducted from the above lifting capacities. Lifting capacities are based on the machine standing on a firm, uniform supporting surface. The use of a work tool attachment point to handle/lift objects, could affect the machine lift performance.

Lift capacity stays with ±5% for all available track shoes.

Always refer to the appropriate Operation and Maintenance Manual for specific product information.

336D2/D2 L Hydraulic Excavator Specifications

336D2 Work Tool Offering Guide*

Boom Type	Reach HD			Mass
Stick Size	R3.9DB	R3.2DB	R2.8DB	M2.55
Hydraulic Hammer	H140Es H160Es	H140Es H160Es	H140Es H160Es	H140Es H160Es H180Es
Multi-Processor	MP20 with CC Jaw MP20 with CR Jaw MP20 with PP Jaw MP20 with PS Jaw MP20 with S Jaw MP20 with TS Jaw	MP20 with CC Jaw MP20 with CR Jaw MP20 with PP Jaw MP20 with PS Jaw MP20 with S Jaw MP20 with TS Jaw	MP20 all Jaw Options MP30 with CC Jaw MP30 with CR Jaw MP30 with PS Jaw	MP30 with CC Jaw MP30 with CR Jaw MP30 with PP Jaw MP30 with PS Jaw MP30 with S Jaw
Crusher	P325	P325	P325 P335	P335
Pulverizer	P225	P225	P225 P235	P325
Demolition and Sorting Grapple	G325B	G325B G330	G325B G330	G330
Mobile Scrap and Demolition Shear	S325B	S325B	S325B	S365C
Compactor (Vibratory Plate)	CVP110	CVP110	CVP110	CVP110
Contractors' Grapple	G130B	G130B	G130B	
Trash Grapple				
Thumbs				
Orange Peel Grapples				
Rakes				
Center-Lock Coupler				
CW Quick Coupler				

These work tools are available for the 336D2. Consult your Cat dealer for proper match.

*Offerings may not be available in all areas.

Matches are dependent on excavator configurations, pin-on or with quick coupler installation, stick or boom mounted, working over the front or over the side. Consult your Cat dealer to determine what is offered in your area and for proper work tool match.

336D2/D2 L Hydraulic Excavator Specifications

336D2 L Work Tool Offering Guide*

Boom Type Stick Size	Reach HD			Mass	
	R3.9DB	R3.2DB	R2.8DB	M2.55	M2.15
Hydraulic Hammer	H140Es H160Es	H140Es H160Es	H140Es H160Es H180Es	H140Es H160Es H180Es	H140Es H160Es
Multi-Processor	MP20 with CC Jaw MP20 with CR Jaw MP20 with PP Jaw MP20 with PS Jaw MP20 with S Jaw MP20 with TS Jaw	MP20 all Jaw Options MP30 with CC Jaw MP30 with CR Jaw MP30 with S Jaw	MP20 all Jaw Options MP30 with CC Jaw MP30 with CR Jaw MP30 with PS Jaw MP30 with S Jaw	MP30 with CC Jaw MP30 with CR Jaw MP30 with PP Jaw MP30 with PS Jaw MP30 with S Jaw MP30 with TS Jaw	MP30 with CC Jaw MP30 with CR Jaw MP30 with PP Jaw MP30 with PS Jaw MP30 with S Jaw MP30 with TS Jaw
Crusher	P325	P325 P335	P325 P335	P335	P335
Pulverizer	P225	P225 P235	P225 P235	P325	P325
Demolition and Sorting Grapple	G325B	G325B G330	G325B G330	G330	G330
Mobile Scrap and Demolition Shear	S325B	S325B	S325B	S365C	S340 S365C
Compactor (Vibratory Plate)	CVP110	CVP110	CVP110	CVP110	CVP110
Contractors' Grapple	G130B	G130B	G130B		
Trash Grapple					
Thumbs					
Orange Peel Grapples					
Rakes					
Center-Lock Coupler					
CW Quick Coupler					

These work tools are available for the 336D2 L. Consult your Cat dealer for proper match.

*Offerings may not be available in all areas.

Matches are dependent on excavator configurations, pin-on or with quick coupler installation, stick or boom mounted, working over the front or over the side. Consult your Cat dealer to determine what is offered in your area and for proper work tool match.

336D2/D2 L Hydraulic Excavator Specifications

Bucket Specifications and Compatibility

	Linkage	Width		Capacity		Weight		Fill	336D2				336D2 L				
		mm	in	m ³	yd ³	kg	lb		%	HD Reach Boom		Mass Boom		HD Reach Boom		Mass Boom	
										R3.2DB (10'6") Stick	R2.8DB (9'2") Stick	M2.55TB (8'4") Stick	M2.15TB (7'1") Stick	R3.2DB (10'6") Stick	R2.8DB (9'2") Stick	M2.55TB (8'4") Stick	M2.15TB (7'1") Stick
										600 mm (24") Track Shoes				600 mm (24") Track Shoes			
DB Linkage without Quick Coupler																	
General Duty (GD)	DB	1350	53	1.64	2.14	1173	2,585	100%	●	●			●	●			
	DB	1650	65	2.11	2.76	1352	2,979	100%	○	○			○	○			
	DB	1800	71	2.35	3.08	1453	3,202	100%	○	○			○	○			
	TB	1500	60	2.14	2.80	1872	4,126	100%			○	○			○	○	
	TB	1650	66	2.41	3.16	2027	4,468	100%			○	○			○	○	
General Duty (GDC)	DB	750	30	0.94	1.23	952	2,099	100%	●	●			●	●			
	DB	900	36	1.19	1.56	1040	2,292	100%	●	●			●	●			
	DB	1050	42	1.46	1.91	1147	2,528	100%	●	●			●	●			
	DB	1200	48	1.73	2.26	1232	2,716	100%	○	○			●	●			
	DB	1350	54	2.00	2.62	1342	2,957	100%	○	○			○	●			
	DB	1500	60	2.27	2.98	1451	3,197	100%	○	○			○	○			
	DB	1650	66	2.55	3.33	1536	3,386	100%	◇	◇			○	○			
Heavy Duty (HD)	DB	750	30	0.73	0.95	1031	2,273	100%	●	●			●	●			
	DB	900	36	0.95	1.24	1178	2,595	100%	●	●			●	●			
	DB	1050	42	1.17	1.54	1267	2,793	100%	●	●			●	●			
	DB	1200	48	1.40	1.84	1398	3,080	100%	●	●			●	●			
	DB	1350	54	1.64	2.14	1481	3,265	100%	○	○			●	●			
	DB	1350	54	1.64	2.14	1459	3,215	100%	○	○			●	●			
	DB	1500	60	1.88	2.46	1600	3,526	100%	○	○			○	●			
	DB	1500	60	1.88	2.46	1566	3,452	100%	○	○			○	●			
	DB	1650	66	2.12	2.77	1730	3,814	100%	○	○			○	○			
	DB	1650	66	2.12	2.77	1697	3,740	100%	○	○			○	○			
	DB	1800	72	2.36	3.08	1851	4,080	100%	◇	◇			○	○			
	TB	1650	66	2.41	3.16	2210	4,871	100%			○	○			○	○	
	TB	1800	72	2.69	3.52	2423	5,340	100%			◇	○			○	○	
	TB	1800	72	2.69	3.52	2381	5,248	100%			◇	○			○	○	
Severe Duty (SD)	DB	750	30	0.73	0.95	1096	2,415	90%	●	●			●	●			
	DB	900	36	0.95	1.24	1252	2,760	90%	●	●			●	●			
	DB	1050	42	1.17	1.54	1353	2,981	90%	●	●			●	●			
	DB	1200	48	1.40	1.84	1493	3,292	90%	●	●			●	●			
	DB	1350	54	1.64	2.14	1599	3,524	90%	○	○			●	●			
	DB	1650	66	2.15	2.81	1827	4,028	90%	○	○			○	○			
	TB	1350	54	1.87	2.44	2065	4,551	90%			○	●			●	●	
	TB	1650	66	2.41	3.16	2385	5,257	90%			○	○			○	○	
	TB	1750	69	2.40	3.14	2454	5,409	90%			○	○			○	○	
Extreme Duty Power (XDP)	TB	1550	61	2.00	2.59	2516	5,545	90%			○	○			○	○	
Maximum load with pin on (payload + bucket)									kg	4240	4405	5145	5765	5160	5365	5535	6065
									lb	9,345	9,709	11,340	12,706	11,373	11,824	12,199	13,367

The above loads are in compliance with hydraulic excavator standard EN474, they do not exceed 87% of hydraulic lifting capacity or 75% of tipping capacity with front linkage fully extended at ground line with bucket curled.

Capacity based on ISO 7451.

Bucket weight with General Duty tips.

Maximum Material Density:

- 2100 kg/m³ (3,500 lb/yd³)
- 1200 kg/m³ (2,000 lb/yd³)
- ⊙ 1800 kg/m³ (3,000 lb/yd³)
- ◇ 900 kg/m³ (1,500 lb/yd³)
- ⊖ 1500 kg/m³ (2,500 lb/yd³)
- X Not recommended

336D2/D2 L Hydraulic Excavator Specifications

Bucket Specifications and Compatibility

	Linkage	Width		Capacity		Weight		Fill	336D2				336D2 L				
									HD Reach Boom		Mass Boom		HD Reach Boom		Mass Boom		
									R3.2DB (10'6") Stick	R2.8DB (9'2") Stick	M2.55TB (8'4") Stick	M2.15TB (7'1") Stick	R3.2DB (10'6") Stick	R2.8DB (9'2") Stick	M2.55TB (8'4") Stick	M2.15TB (7'1") Stick	
									600 mm (24") Track Shoes				600 mm (24") Track Shoes				
DB Linkage with Center-Lock Quick Coupler																	
General Duty (GD)	DB	1350	53	1.64	2.14	1173	2,585	100%	⊖	⊖			●	●			
	DB	1650	65	2.11	2.76	1352	2,979	100%	◇	○			⊖	⊖			
	DB	1800	71	2.35	3.08	1453	3,202	100%	◇	◇			○	⊖			
	TB	1500	60	2.14	2.80	1872	4,126	100%			○	⊖			⊖	⊖	
	TB	1650	66	2.41	3.16	2027	4,468	100%			◇	○			○	⊖	
General Duty (GDC)	DB	750	30	0.94	1.23	952	2,099	100%	●	●			●	●			
	DB	900	36	1.19	1.56	1040	2,292	100%	●	●			●	●			
	DB	1050	42	1.46	1.91	1147	2,528	100%	⊙	⊙			●	●			
	DB	1200	48	1.73	2.26	1232	2,716	100%	○	⊖			⊙	●			
	DB	1350	54	2.00	2.62	1342	2,957	100%	○	○			⊖	⊙			
	DB	1500	60	2.27	2.98	1451	3,197	100%	◇	◇			○	⊖			
	DB	1650	66	2.55	3.33	1536	3,386	100%	⊖	◇			○	○			
Heavy Duty (HD)	DB	750	30	0.73	0.95	1031	2,273	100%	●	●			●	●			
	DB	900	36	0.95	1.24	1178	2,595	100%	●	●			●	●			
	DB	1050	42	1.17	1.54	1267	2,793	100%	●	●			●	●			
	DB	1200	48	1.40	1.84	1398	3,080	100%	⊖	⊙			●	●			
	DB	1350	54	1.64	2.14	1481	3,265	100%	○	⊖			⊙	●			
	DB	1350	54	1.64	2.14	1459	3,215	100%	○	⊖			⊙	●			
	DB	1500	60	1.88	2.46	1600	3,526	100%	◇	○			⊖	⊖			
	DB	1500	60	1.88	2.46	1566	3,452	100%	◇	○			⊖	⊙			
	DB	1650	66	2.12	2.77	1730	3,814	100%	◇	◇			○	⊖			
	DB	1650	66	2.12	2.77	1697	3,740	100%	◇	◇			○	⊖			
	DB	1800	72	2.36	3.08	1851	4,080	100%	⊖	⊖			○	○			
	TB	1650	66	2.41	3.16	2210	4,871	100%			◇	○			○	○	
	TB	1800	72	2.69	3.52	2423	5,340	100%			⊖	◇			◇	○	
TB	1800	72	2.69	3.52	2381	5,248	100%			⊖	◇			◇	○		
Severe Duty (SD)	DB	750	30	0.73	0.95	1096	2,415	90%	●	●			●	●			
	DB	900	36	0.95	1.24	1252	2,760	90%	●	●			●	●			
	DB	1050	42	1.17	1.54	1353	2,981	90%	●	●			●	●			
	DB	1200	48	1.40	1.84	1493	3,292	90%	⊙	⊙			●	●			
	DB	1350	54	1.64	2.14	1599	3,524	90%	○	⊖			●	●			
	DB	1650	66	2.15	2.81	1827	4,028	90%	◇	◇			⊖	⊖			
	TB	1350	54	1.87	2.44	2065	4,551	90%			⊖	⊙			⊙	●	
	TB	1650	66	2.41	3.16	2385	5,257	90%			◇	○			○	⊖	
Severe Duty Power (SDP)	TB	1750	69	2.40	3.14	2454	5,409	90%			◇	○			○	○	
Extreme Duty Power (XDP)	TB	1550	61	2.00	2.59	2516	5,545	90%			○	⊖			○	⊖	
Maximum load with coupler (payload + bucket)									kg	3682	3847	4587	5207	4602	4807	4977	5507
									lb	8,115	8,479	10,110	11,476	10,143	10,594	10,969	12,137

The above loads are in compliance with hydraulic excavator standard EN474, they do not exceed 87% of hydraulic lifting capacity or 75% of tipping capacity with front linkage fully extended at ground line with bucket curled.

Capacity based on ISO 7451.

Bucket weight with General Duty tips.

Maximum Material Density:

- 2100 kg/m³ (3,500 lb/yd³)
- ⊙ 1800 kg/m³ (3,000 lb/yd³)
- ⊖ 1500 kg/m³ (2,500 lb/yd³)
- 1200 kg/m³ (2,000 lb/yd³)
- ◇ 900 kg/m³ (1,500 lb/yd³)
- X Not recommended

336D2/D2 L Hydraulic Excavator Specifications

Bucket Specifications and Compatibility

	Linkage	Width		Capacity		Weight		Fill	336D2				336D2 L				
									HD Reach Boom		Mass Boom		HD Reach Boom		Mass Boom		
									R3.2DB (10'6") Stick	R2.8DB (9'2") Stick	M2.55TB (8'4") Stick	M2.15TB (7'1") Stick	R3.2DB (10'6") Stick	R2.8DB (9'2") Stick	M2.55TB (8'4") Stick	M2.15TB (7'1") Stick	
									600 mm (24") Track Shoes				600 mm (24") Track Shoes				
With Quick Coupler (CW45, CW45s)																	
General Duty (GD)	DB	1050	41	1.17	1.53	986	2,172	100%	●	●			●	●			
	DB	1200	47	1.40	1.83	1064	2,345	100%	⊙	●			●	●			
	DB	1350	53	1.64	2.14	1143	2,519	100%	⊖	⊖			●	●			
	DB	1500	59	1.87	2.45	1245	2,745	100%	○	⊖			⊙	⊙			
	DB	1650	65	2.11	2.76	1324	2,918	100%	○	○			⊖	⊖			
Heavy Duty (HD)	DB	1350	54	1.64	2.14	1417	3,122	100%	○	⊖			⊙	●			
	DB	1500	60	1.88	2.46	1514	3,337	100%	○	○			⊖	⊙			
	DB	1650	66	2.12	2.77	1647	3,629	100%	◇	◇			⊖	⊖			
	TB	1650	66	2.41	3.16	2117	4,666	100%			◇	○			○	⊖	
Severe Duty (SD)	DB	1050	42	1.17	1.54	1272	2,803	90%	●	●			●	●			
	DB	1650	66	2.15	2.81	1802	3,971	90%	◇	◇			⊖	⊖			
	TB	1350	54	1.87	2.44	1974	4,351	90%			●	⊙			⊙	●	
	TB	1650	66	2.41	3.16	2295	5,058	90%			◇	○			○	⊖	
Maximum load with coupler (payload + bucket)									kg	3750	3915	4640	5260	4670	4875	5030	5560
									lb	8,265	8,629	10,227	11,593	10,293	10,745	11,086	12,254

The above loads are in compliance with hydraulic excavator standard EN474, they do not exceed 87% of hydraulic lifting capacity or 75% of tipping capacity with front linkage fully extended at ground line with bucket curled.

Capacity based on ISO 7451.

Bucket weight with General Duty tips.

Maximum Material Density:

● 2100 kg/m³ (3,500 lb/yd³)

⊙ 1800 kg/m³ (3,000 lb/yd³)

⊖ 1500 kg/m³ (2,500 lb/yd³)

○ 1200 kg/m³ (2,000 lb/yd³)

◇ 900 kg/m³ (1,500 lb/yd³)

X Not recommended

Standard Equipment

Standard equipment may vary. Consult your Cat dealer for details.

ENGINE

- Diesel C9 ACERT engine
- 2300 m (7,546 ft) altitude capability
- 65 amp alternator
- Air intake heater
- High power version with Power Management Mode
- Radial seal air filters (primary and secondary filter)
- Automatic engine speed control
- Water separator with water level indicator sensor
- Waved fin radiator with space for cleaning
- Two-speed travel
- Two (2) micron fuel filters
- Electric priming pump

HYDRAULIC SYSTEM

- Capability of installing additional valves and circuits
- Regeneration circuits for boom and stick
- Reverse swing damping valve
- Automatic swing parking brake

CAB

- Retractable seat belt (51 mm [2 in]; 76 mm [3 in] width)
- 70/30 split front windshield
- Laminated upper front windshield and tempered other windows
- Sliding upper door window
- Bi-level air conditioner (automatic) with defroster (pressurized cab)
- Color LCD display with warning, filter/fluid change, and working hour information
- Neutral lever (lock out) for all controls
- Travel control pedals with removable hand levers
- Radio mounting (DIN size)
- 12V – 2× maximum 10A power supply
- Two stereo speakers
- Beverage holder
- Coat hook, ashtray, literature holder
- Openable roof hatch
- Washable floor mat

UNDERCARRIAGE

- Idler and center section track guiding guards
- Towing eye on base frame
- Grease lubricated track GLT2, resin seal

ELECTRICAL

- Circuit breaker
- Light, boom mounted, left and right
- Light, storage box mounted

SAFETY AND SECURITY

- Cat one key security system
- Door and compartment locks
- Signaling/warning horn
- Rearview mirrors
- Emergency engine shutoff switch
- Emergency exit rear window
- Capability to connect a beacon

COUNTERWEIGHT

- 6.0 mt (6.6 t) counterweight

Optional Equipment

Optional equipment may vary. Consult your Cat dealer for details.

FRONT PARTS

- Heavy duty Reach boom
 - R3.9DB stick
 - R3.2DB stick
 - R2.8DB stick
- Mass Excavation boom
 - M2.55TB stick
 - M2.15TB stick
- Bucket linkage
 - DB Bucket linkage (with/without lifting eye)
 - TB Bucket linkage (with/without lifting eye)

UNDERCARRIAGE

- Heavy duty bottom guard
- Standard/HD Swivel guard
- HD Travel motor guard
- Full length track guiding guards
- FOGS (bolt-on)
- 600 mm, 700 mm, 800 mm (24 in, 28 in, 32 in) Triple Grouser tracks

HYDRAULICS

- Boom and Stick High pressure lines
- Boom and Stick Medium pressure lines
- Boom, Stick and Bucket Quick coupler lines
- Boom/Stick lowering control device
- Quick coupler circuit
- Fine swing control
- Bio-oil capability

CAB

- Roll Over Protective Structure (ROPS) cab
- Mechanical suspension seat, with head rest
- Air suspension seat, with head rest and seat heater
- 12V-10A power supply with two (2) cigar lighter type sockets
- Rain protector for front windshield
- AM/FM radio
- Control pattern quick-changer
- Third pedal for straight travel

OTHER OPTIONAL EQUIPMENT

- Travel alarm
- Starting kit, cold weather
- Electric refueling pump with auto shut off

INTEGRATED TECHNOLOGIES

- Rearview camera
- AccuGrade™ ready attachment
- Cat Product Link™

For more complete information on Cat products, dealer services, and industry solutions, visit us on the web at www.cat.com

© 2015 Caterpillar
All rights reserved

Materials and specifications are subject to change without notice. Featured machines in photos may include additional equipment. See your Cat dealer for available options.

CAT, CATERPILLAR, SAFETY.CAT.COM, their respective logos, "Caterpillar Yellow" and the "Power Edge" trade dress, as well as corporate and product identity used herein, are trademarks of Caterpillar and may not be used without permission.

AEHQ7176-02 (04-2015)
Replaces AEHQ7176-01
(ADSD-S, AME,
APD, CIS, GCN1)

