



Cat[®] Center-Lock[™] Pin Grabber Coupler

HYDRAULIC EXCAVATORS

FEATURES:

All the Convenience of a Pin Grabber Coupler

- Pin grabber couplers allow work tools to be changed quickly — improving overall production and increasing machine versatility. Coupler is pinned on in place of the bucket using standard pins and allows one machine to be used for multiple tasks on the job site.
- Cat[®] Center-Lock[™] Pin Grabber Coupler is built around the same interface as previous pin grabber couplers and will engage and disengage virtually any Cat bucket or work tool equipped with pins. The key difference is the patent pending locking mechanism integrated into Center-Lock.

Confident, Secure Operation

- Cat Center-Lock Pin Grabber Coupler gives operators confidence through its locking system and visible locking mechanism. At the heart of the Center-Lock is "Over-Center Locking Technology." This technology — very similar to Vise-Grip[®] locking pliers — uses proven principles of physics to keep the coupler locked tight.
- Once Center-Lock has engaged a work tool, the lock is so secure it will stay locked — even in the event of hydraulic failure. Should a pin be inadvertently missed while engaging a work tool, either coupler hook is strong enough to hold the full weight of the work tool on its own.
- The physical locking mechanism is backed up by positive "always on" hydraulic pressure, and a counterbalance valve on the cylinder together provide additional layers of locking protection.
- The lock on the front pin of the work tool is clearly visible to the operator, always showing the status of the coupler: open or closed. This gives the operator confidence a tool is engaged, and makes changing tools faster. Those on the job site within view of the secondary lock can also be reassured the coupler is engaged and locked tight on to the tool.

Improved Productivity

- Center-Lock is easy to operate, regardless of operator skill level, and it is easier to train new operators to use. The ability to see when the coupler is open, or closed, makes it intuitive to use, and saves time each time a tool is changed.
- Because engaging the locking mechanism in Center-Lock does not require gravity to actuate — there is no need to boom in, stick up, and invert the attachment to lock on. Simplified operation allows quicker tool change regardless of boom or stick position. And, it is possible to engage and disengage work tools in limited overhead situations.

Broad Compatibility

- Available for 311-336 Hydraulic Excavators.
- Picks up virtually any Cat bucket or work tool with pins. Also compatible with a wide range of non-Cat buckets.

Easy to Maintain

- Straightforward design requires only daily greasing to maintain.
- No external or internal locking bars, springs or other loose parts.
- Connector lines are routed through the coupler to protect hoses from damage.



CATERPILLAR[®]

Cat Center-Lock Pin Grabber Coupler

The solution is obvious: Over-Center Technology

Improved Pin Grabber Coupler

Center-Lock Pin Grabber Coupler engages and disengages tools in a similar fashion to other pin grabber couplers. The difference with this coupler is found in the patent pending locking mechanism inside the coupler.

■ **Cylinder walls** are much thicker and the diameter of the cylinder itself is much larger — giving increased closing power and resistance to extreme forces.

■ A highly visible **Secondary Lock** clearly shows an operator when the coupler is locked on to the pin of a bucket or work tool.

Visibility gives confidence to make tool changes quickly and safely — saving time with every tool change.

And, the **Secondary Lock** has the strength to hold the full weight of a bucket if a back pin is missed when engaging the attachment.

■ Hydraulic pressure pushes the **Center-Lock Rocker** into place and keeps the **Secondary Lock** securely locked over the front bucket pin. Even in the event of hydraulic failure the coupler stays locked on to the pin.

■ **Counterbalance Valve** and positively pressurized hydraulics assure the coupler is locked on to the work tool.

■ **Primary Hook** grasps the back bucket pin and tightly secures the work tool.

■ **Over-Center Technology:** Once the locking mechanism passes over center, the **Secondary Lock** is held firmly over the front bucket pin. Just like the jaws on a set of locking pliers, the secondary lock holds, and it takes a specific action to release the lock.

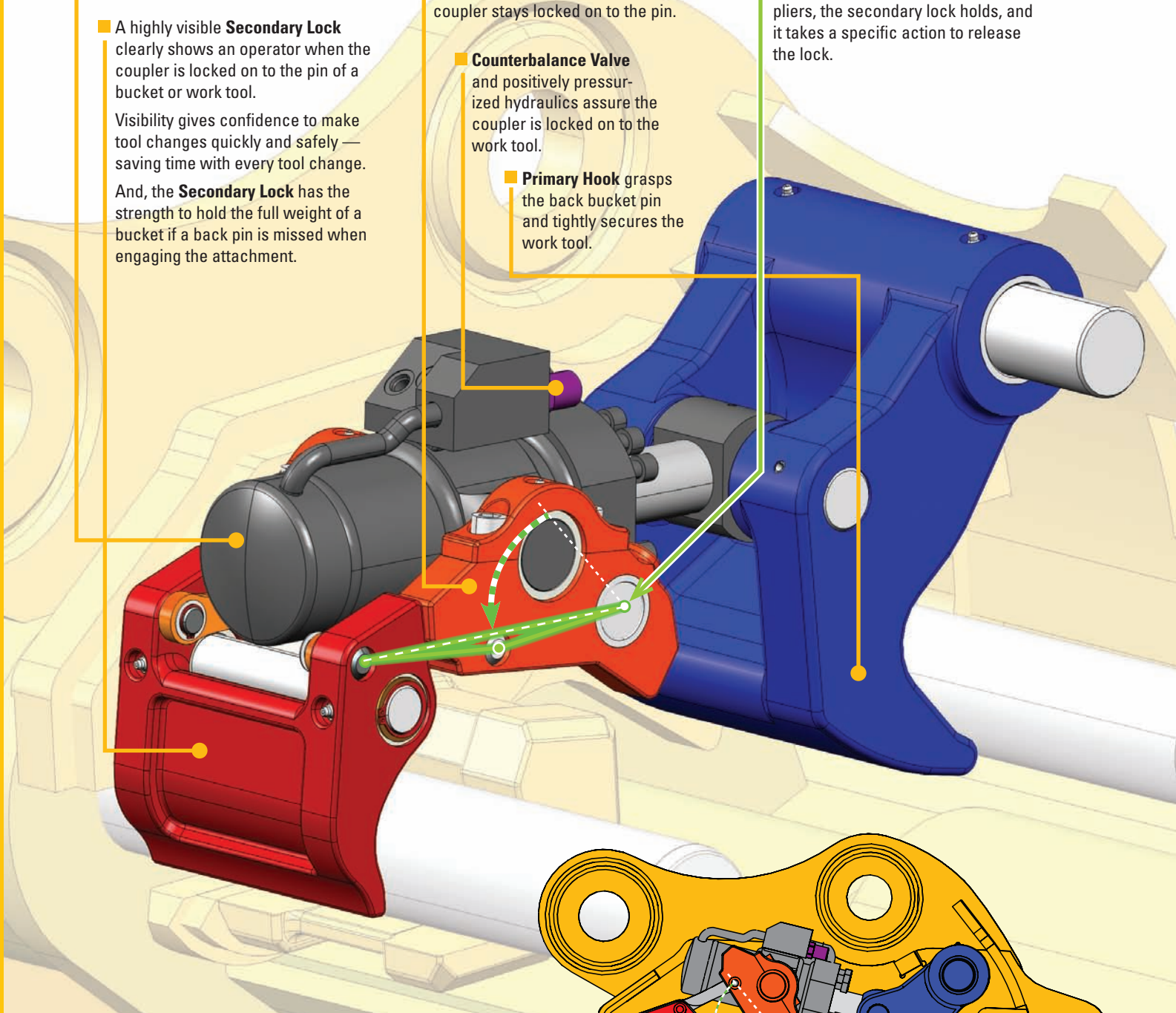

Coupler: Unlocked

How Over-Center Technology Works

- Over-Center locking is found only in Center-Lock Pin Grabber Couplers. This technology works on the same principle as a set of Vise-Grip® locking pliers.
- As you squeeze the handles to close the jaws of locking pliers you will notice some resistance until just past halfway. Then, the jaws just seem to snap shut automatically. This is the over center lock taking place. Once locked, the only way to release the jaws is to take deliberate, specific action. Pulling and prying on the handles simply will not release the lock.
- Once the lock is engaged in the Center-Lock Pin Grabber Coupler — the operator can only unlock the coupler by moving a switch in the cab and curling the bucket. Any forces applied from either bucket pin will only cause the over center lock to close even tighter.

Engage & Disengage Tools in Limited Overhead Situations

There is no need to boom in, stick up and invert the attachment to unlock Center-Lock. Simplified operation allows attachments to be engaged and disengaged in limited overhead conditions such as under bridge decks and power lines.

Unlocking Center-Lock

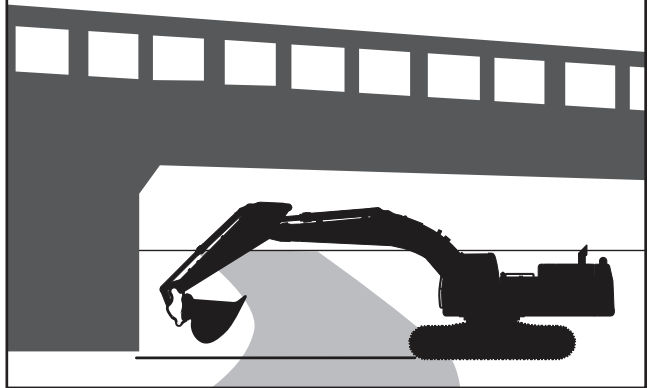

Unlocking a traditional pin grabber coupler

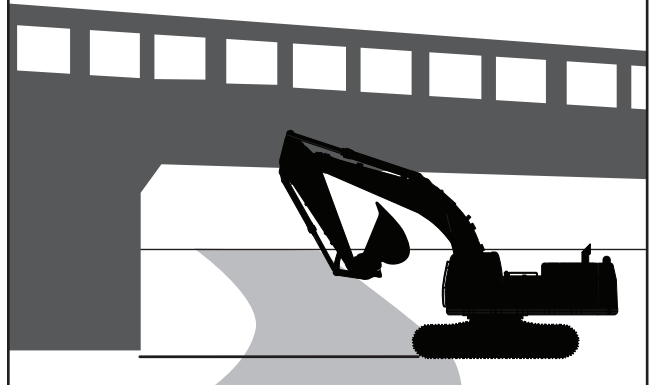

Visible Secondary Lock

The lock on the front pin of the attachment is clearly visible to the operator — always showing the status of the coupler: open or closed.

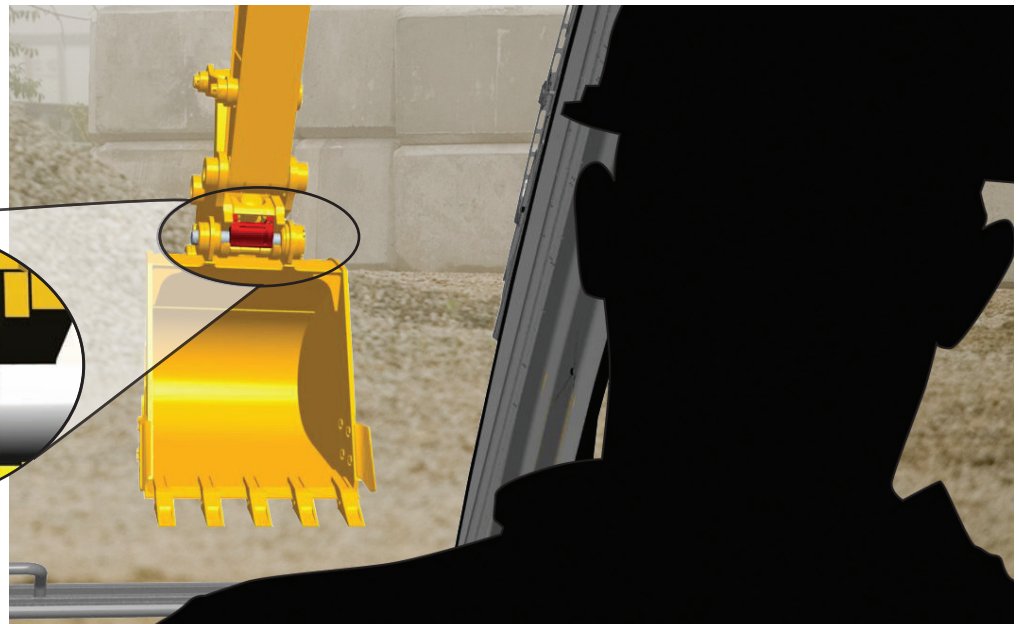
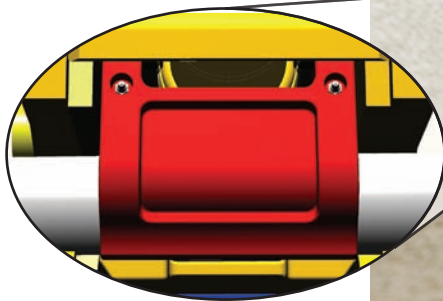

Cat Center-Lock Pin Grabber Coupler

Machine Compatibility

Center-Lock is available for 311-336 Hydraulic Excavators.

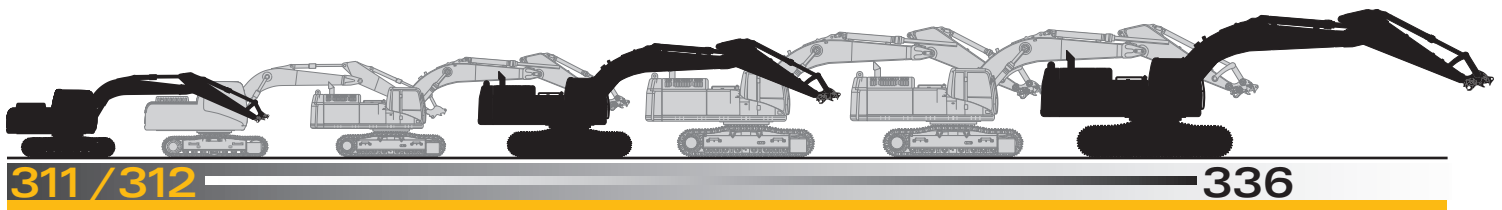

Center-Lock Pin Grabber Coupler Line Up

Center-Lock Couplers are offered in seven sizes, designed to fit with eight different machine linkages (below) for the range of excavators (above).

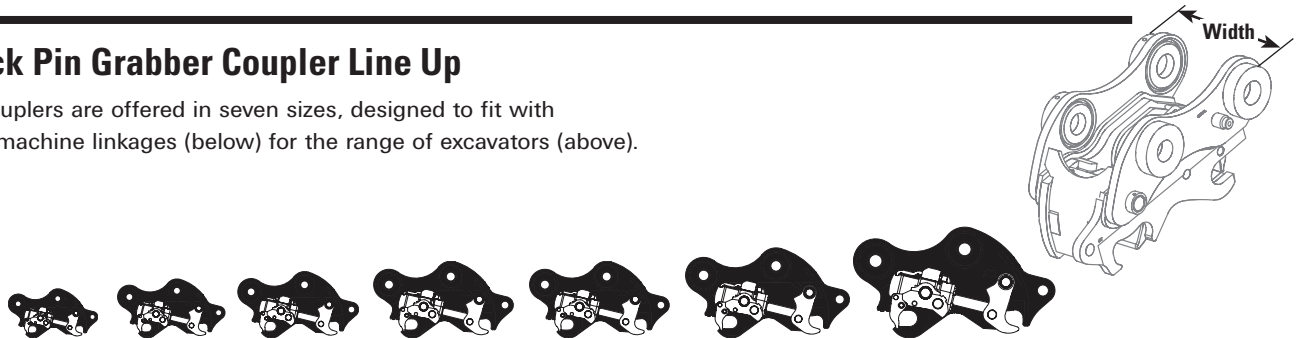

Machine Linkage	312	315	B	CB	DB	TB	VB
Weight: kg (lb)	224 (494)	357 (707)	378 (833)	504 (1111)	558 (1230)	833 (1836)	1227 (2706)
Width: mm (in)	381 (15.0)	460 (18.1)	512 (20.2)	590 (23.2)	586 (23.1)	693 (27.3)	859 (33.8)
Weight: kg (lb)				Trenching Coupler 502 (1106)		Trenching Coupler 831 (1831)	
Width: mm (in)				570 (22.4)		680 (26.8)	

Work Tool Compatibility

Center-Lock Pin Grabber Couplers are designed to engage and disengage the same range of tools as previous pin grabber couplers.

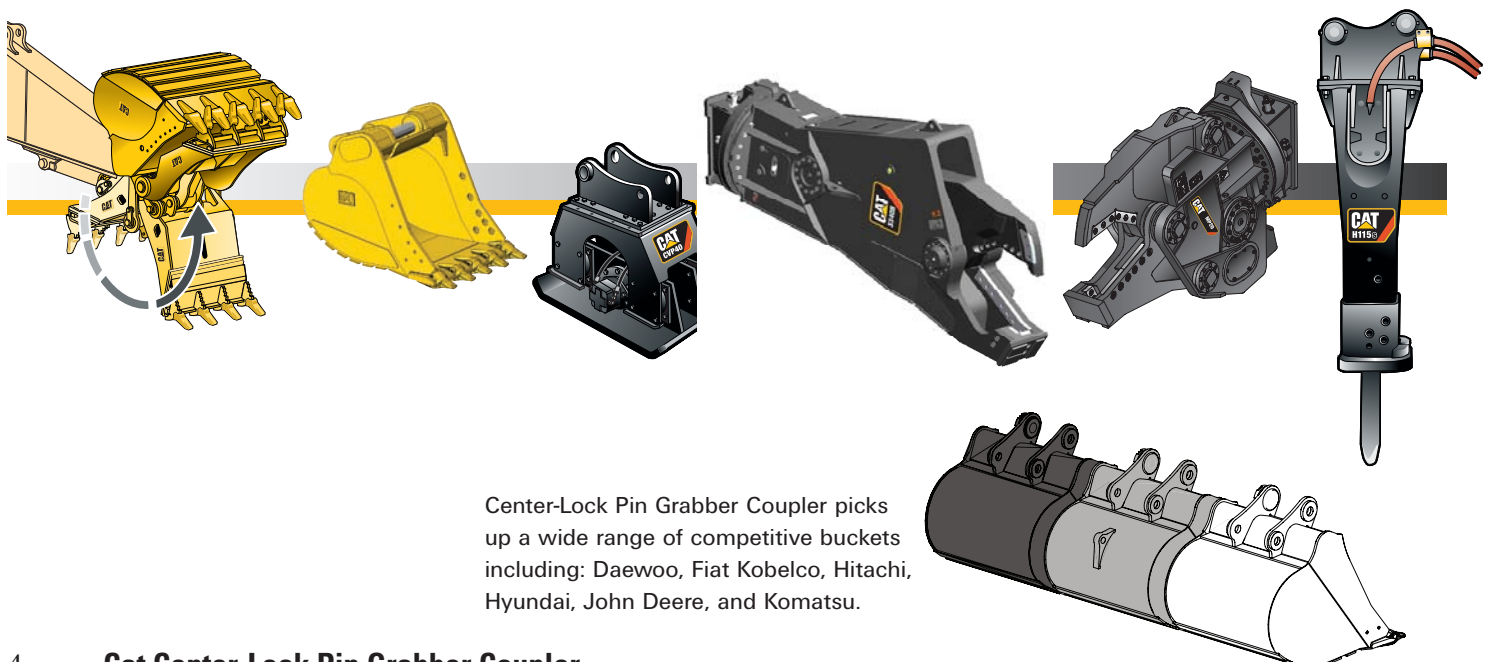

Center-Lock Pin Grabber Coupler picks up a wide range of competitive buckets including: Daewoo, Fiat Kobelco, Hitachi, Hyundai, John Deere, and Komatsu.

Center-Lock Clamping Spacers

Caterpillar has a better solution to multiple shims!

- Clamping spacers easily “fill the gap” when the face spread of a tool is much wider than the coupler — keeping the attachment centered on the coupler. Wide, solid clamping spacers eliminate the need to stack thin shims on the front pin and therefore, eliminate the potential for damaged shims, and the need to weld multiple shims together.
- Center-Lock Clamping Spacer system consists of two solid steel spacers and two locking rings which fit on the front pin. Once set, the spacers stay locked in place.
- Solid steel construction makes them tough enough to withstand frequent coupling and uncoupling of tools.
- Clamping Spacers are available with several different inside dimensions (from 65.5mm to 110.5mm) and thicknesses (from 14mm to 30mm). They are designed to work with the most popular sizes of bucket pins on small, medium and large excavators.

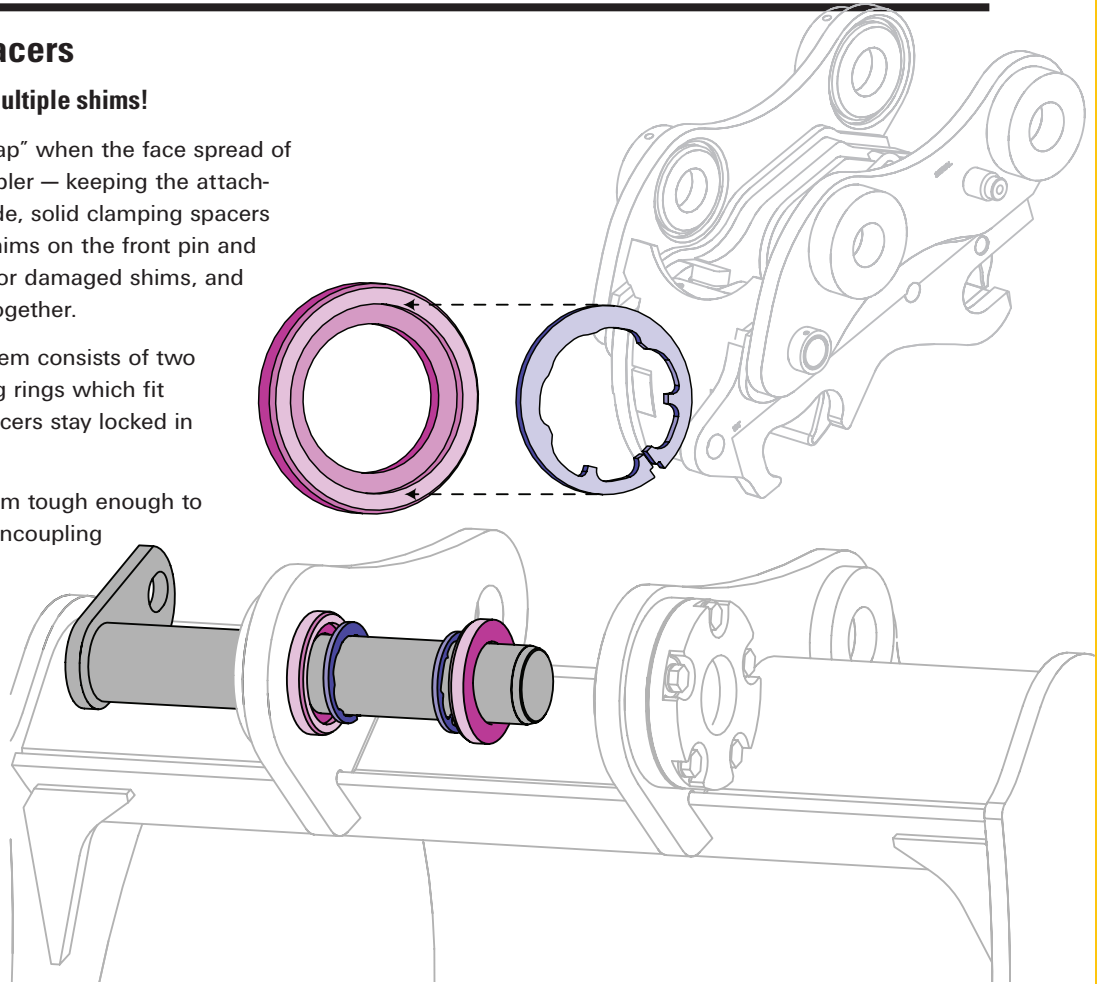

Cat Center-Lock Pin Grabber Coupler

For more complete information on Cat products, dealer services, and industry solutions, visit us on the web at www.cat.com

GEHQ2187 (03-09)

©2009 Caterpillar
All Rights Reserved
Printed in U.S.A.

Materials and specifications are subject to change without notice. Featured machines in photos may include additional equipment. See your Caterpillar dealer for available options.

CAT, CATERPILLAR, their respective logos, "Caterpillar Yellow," and the POWER EDGE trade dress, as well as corporate and product identity used herein, are trademarks of Caterpillar and may not be used without permission.

