

769D Off-Highway Truck

Dimensions

All dimensions are approximate.

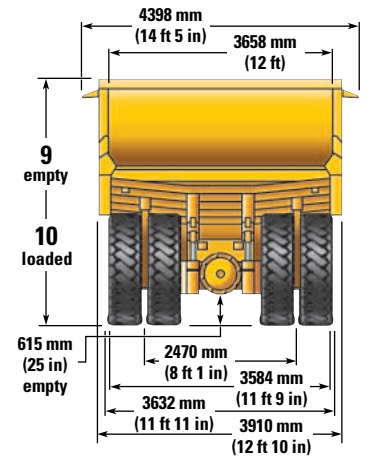
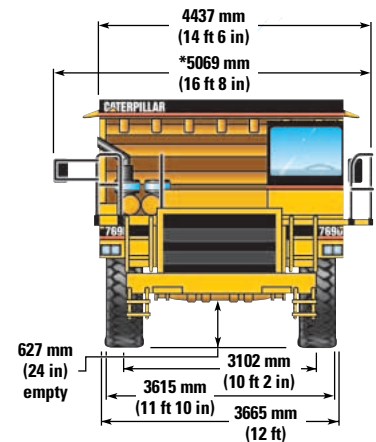
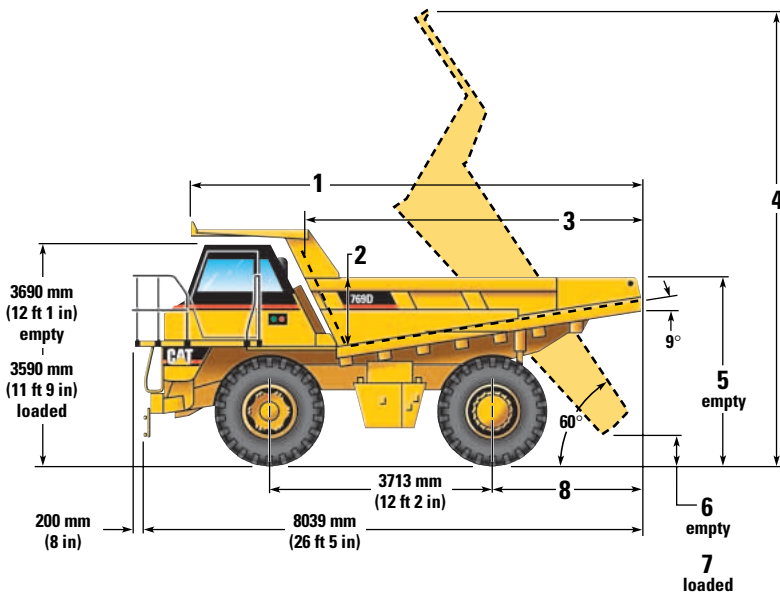

* Operating width to r.h. mirror

Flat Floor

Dual-slope

	Flat Floor		Dual-slope	
1	7615 mm	25 ft 0 in	7430 mm	24 ft 5 in
2	1390 mm	4 ft 7 in	1454 mm	4 ft 9 in
3	5430 mm	17 ft 10 in	5275 mm	17 ft 4 in
4	7751 mm	25 ft 5 in	7709 mm	25 ft 4 in
5	3188 mm	10 ft 6 in	3143 mm	10 ft 4 in
6	465 mm	1 ft 6 in	525 mm	1 ft 9 in
7	315 mm	1 ft 0 in	415 mm	1 ft 4 in
8	2541 mm	8 ft 4 in	2380 mm	7 ft 10 in
9	4072 mm	13 ft 4 in	4027 mm	13 ft 3 in
10	3997 mm	13 ft 1 in	3952 mm	13 ft 0 in

Capacity - Flat Floor - 100% fill factor

Struck	16.5 m ³	21.6 yd ³
Heaped 3:1	21.6 m ³	28.3 yd ³
Heaped 2:1 (SAE)	24.2 m ³	31.7 yd ³
Heaped 1:1	31.7 m ³	41.5 yd ³

Capacity - Dual-slope - 100% fill factor

Struck	17 m ³	22.2 yd ³
Heaped 3:1	21.7 m ³	28.4 yd ³
Heaped 2:1 (SAE)	24.2 m ³	31.7 yd ³
Heaped 1:1	23.7 m ³	31 yd ³

769D Off-Highway Truck

Retarding Performance

The brake performance retarding curves shown in this section are for general guidance only. As each site has many unique environmental and operating conditions that will impact retarding performance, actual site performance could vary considerably from predicted performance. Users should use the retarding speed (gear) recommendations from these tables as a starting point for determining retarding performance and then adjust retarding speeds to their site-specific conditions. In adjusting retarding performance to continuously changing environmental and site-specific conditions, users need to exercise care to maintain brake cooling and machine controllability at all times.

To determine brake retarding performance from retarding tables:

1. Determine the total distance of all downhill grades combined for a given haul profile. This total distance determines the appropriate retarding table (continuous or one of the grade distance tables) applicable to your haul profile.

2. Read from the appropriate gross weight down to percent favorable effective grade. (For these retarding charts, effective grade equals the maximum grade of all downhill haul segments minus rolling resistance – do not use an average grade value.)
3. From the intersection of the gross weight and effective grade line point, read horizontally to the appropriate gear curve. If the horizontal line intersects two gear curves, choose the first gear curve that the horizontal line intersects (reading from right to left) and read the retarding speed performance immediately below this point. If the intersection point falls on a vertical line between two gears, choose the lowest of the two gears to allow for higher engine rpm thus maximizing brake cooling capability.
4. Adjust recommended retarding speeds to site specific (environmental and operational) conditions. If the brake system overheats or specific site conditions dictate (tight turns, short steep grades, manual braking, etc.), reduce ground speed to allow the transmission to shift to the next lower speed range.

----- Empty Weight
- - - - - Gross Machine Weight
71 400 kg (157,000 lb)

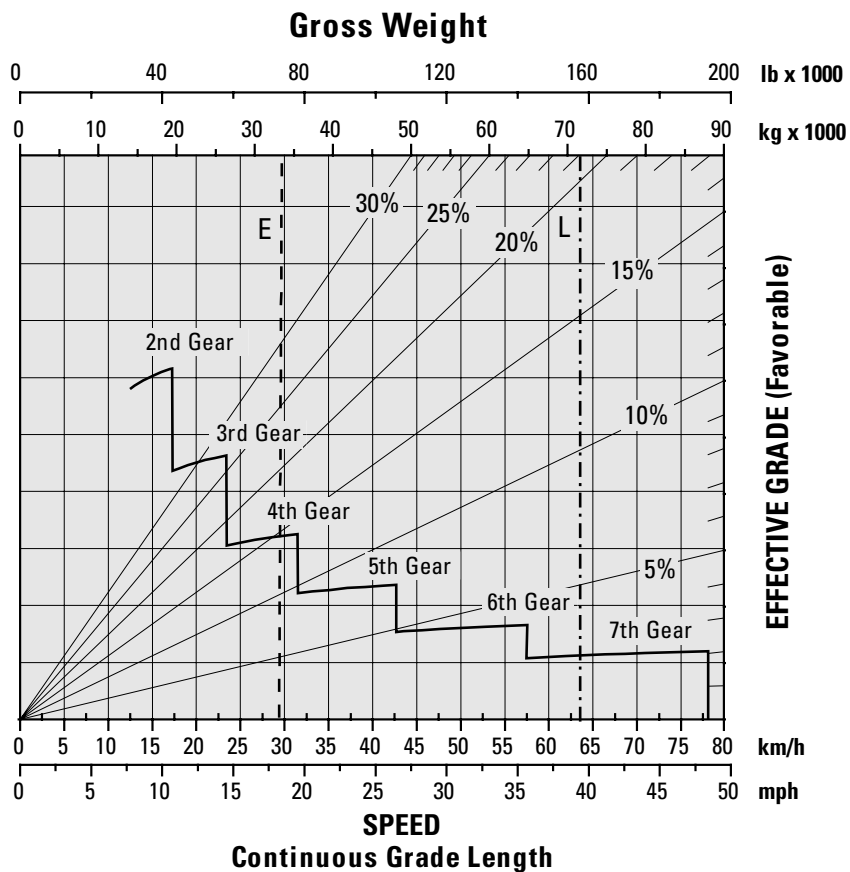

769D Off-Highway Truck

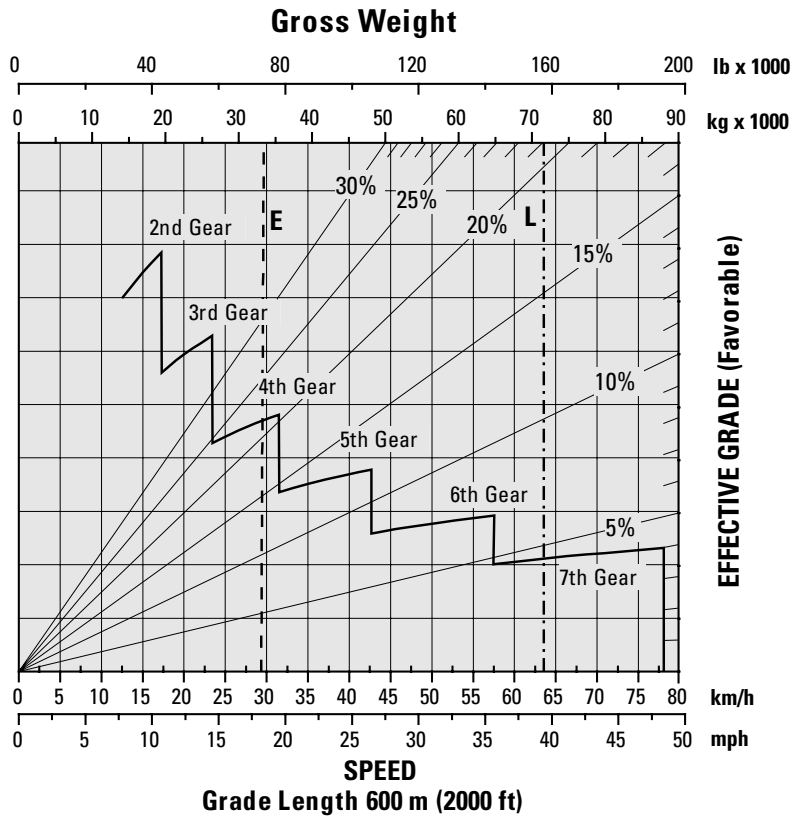
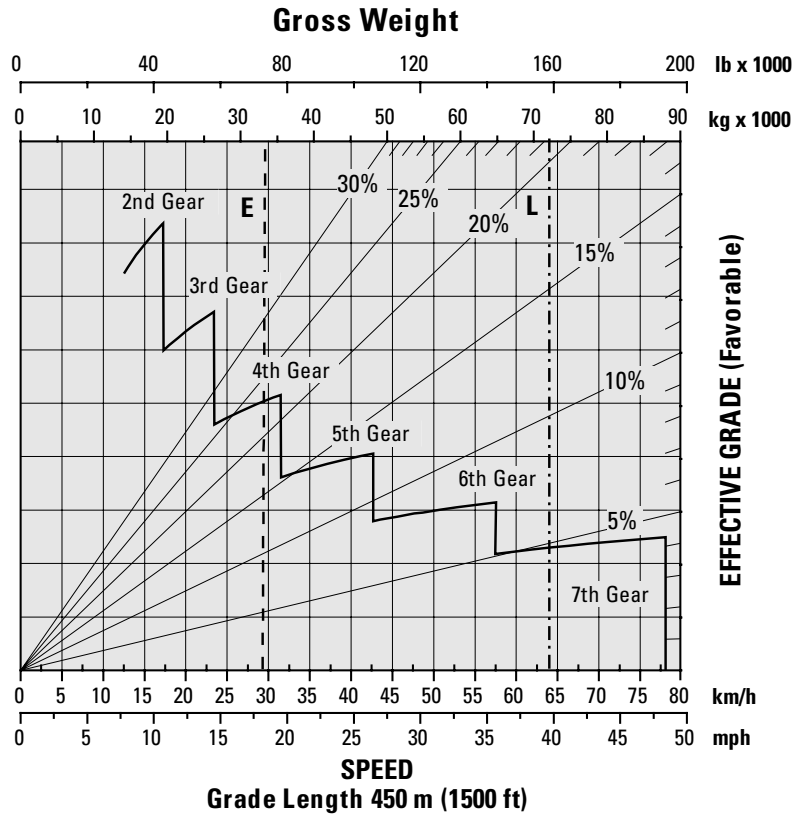

769D Off-Highway Truck

Retarding Performance (continued)

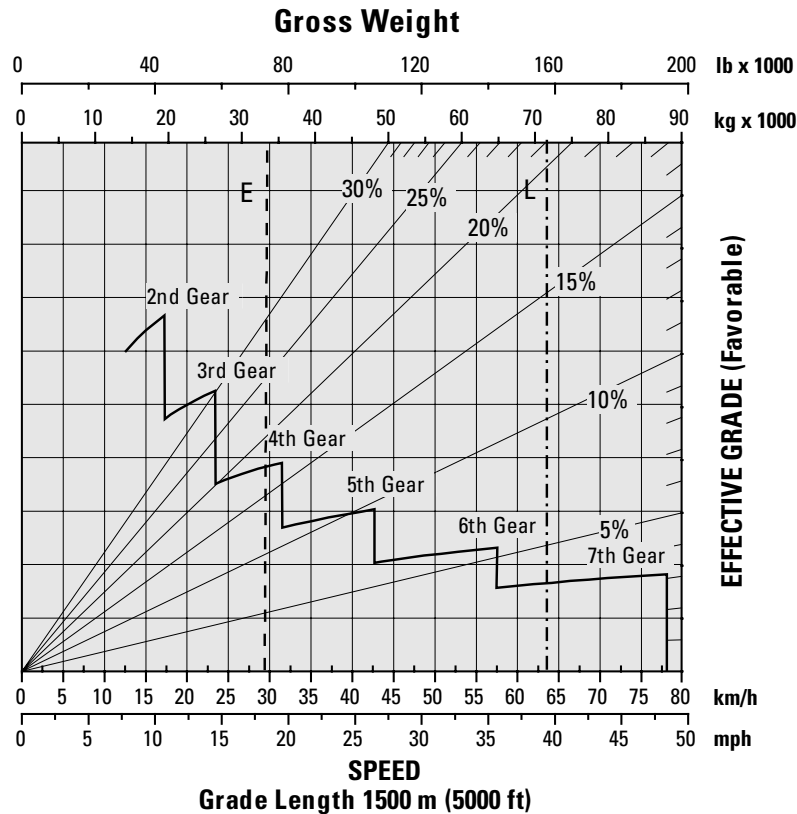
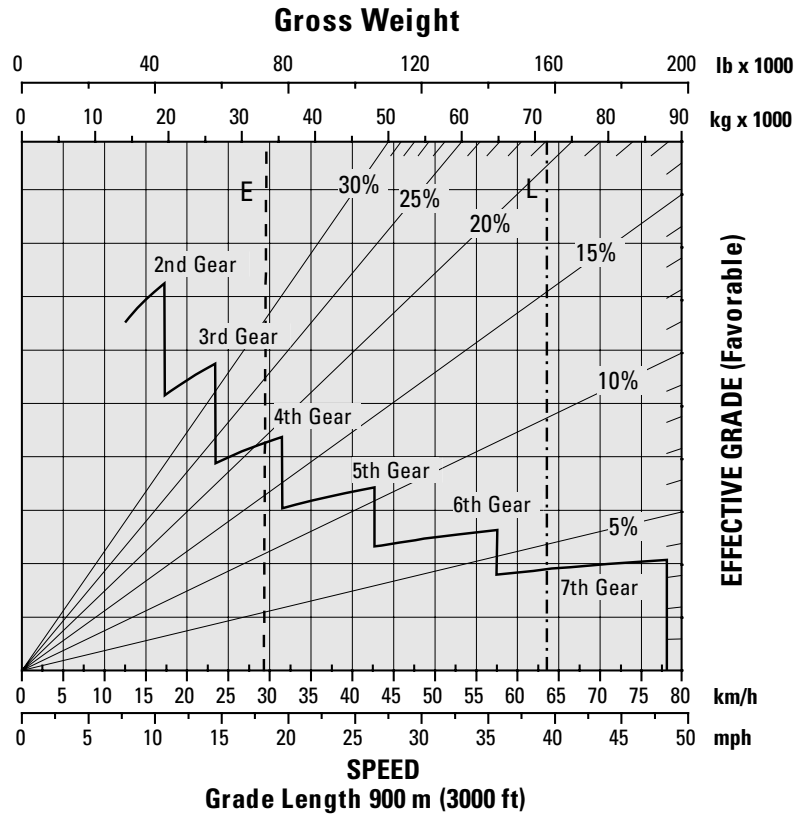

769D Off-Highway Truck

Gradeability/Speed/Rimpull

To determine gradeability performance, read from gross weight down to the percent of total resistance. Total resistance equals actual percent grade plus one percent for each 10 kg/tonne (20 lb/ton) of rolling resistance. From this weight-resistance point, read horizontally to the curve with the highest obtainable gear, then down to maximum speed. Usable rimpull will depend upon traction available and weight on drive wheels.

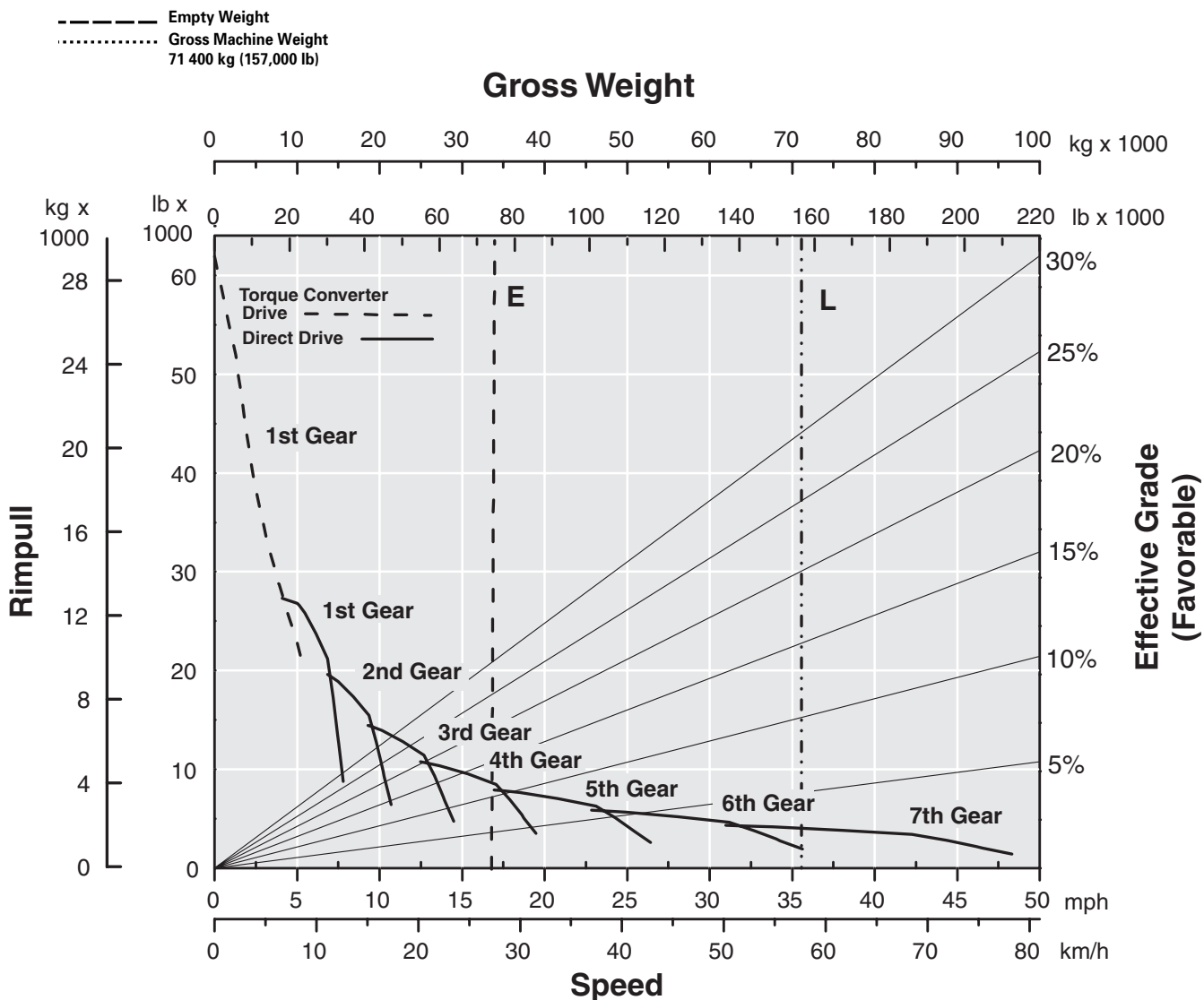

769D Off-Highway Truck

Optional Equipment

With approximate changes in operating weights. Optional equipment may vary.
Consult a Caterpillar Dealer for specifics.

	kg	lb		kg	lb
Air conditioning	90	200	Spare rim (330 mm) 13"	360	800
Automatic lube system	60	135	Traction Control System (TCS)	50	110
Automatic Retarder Control (ARC)	6	13	Truck Bodies:		
Clustered grease fittings	20	50	Dual slope body	7300	16,200
Engine coolant heater - 120-volt	3	7	Body liner for dual-slope body [Liner thickness - 16 mm (.063") floor, 8 mm (.031") front and side walls]	3200	7,000
Engine coolant heater - 240-volt	4	9	Flat floor body	7800	17,200
Engine ground level shut-off	80	180	Body liner for flat floor body [Liner thickness - 16 mm (.063") floor, 8 mm (.031") front and side walls]	3300	7,200
Ether starting aid	5	10	Truck Production Management		
Exhaust diverter/muffler	75	170	System (TPMS)	45	100
Fuel heater kit	5	12	Wheel chocks	25	50
Integrated brake control	56	123	Wiggins fast fuel change	2	5
Muffler	55	120	Wiggins high speed oil change	1	2
Sound suppression package (2000/14/EC compliant)	136	300			

Weight/Payload Calculation*

(Example)

	Flat Floor		Dual-slope	
	kg	lb	kg	lb
Empty Chassis Weight	23 000	50,600	23 000	50,600
Fuel Correction (90% × 140 gal.)	400	882	400	882
Optional Attachments Weight				
Debris Allowance (4% of chassis)	+920	+2024	+920	+2024
Chassis Weight	24 320	53,506	24 320	53,506
Body Weight	7800	17,200	7300	16,200
Body Attachments Weight	+3300	+7200	+3200	+7000
Total Empty Operating Weight	35 420	77,906	34 820	76,706
Target Payload	+35 980	+79,094	+36 580	+80 294
Gross Machine Operating Weight	71 400	157,000	71 400	157,000

*Note: Refer to Caterpillar's 10/10/20 Payload Policy for Quarry and Construction Trucks.