

97G2VK

PRODUCT SPECIFICATIONS

TWO STAGE VARIABLE SPEED GAS FURNACE

FORM NO. 97G2VK-100 (10/2025)



CONFIGURATIONS

- Upflow / Horizontal
- Downflow

VENTING

- 2-speed induced draft motor with stainless steel shaft, steel ball bearings, and fan cooled for long life
- Vent materials for Canadian applications must comply with ULC S636
- Certified for direct vent (2-pipe) or non-direct (1-pipe) applications
- Direct vent refers to a combustion air supply intake pipe installed in conjunction with flue gas vent pipe.

INSTALLATION FEATURES

- Left or right gas and electric entry
- Zero step horizontal conversion
- Removable floor base (upflow/horizontal units) for bottom return air
- All models comply with California's South Coast Air Quality Management district Low NOx requirements

HEAT EXCHANGER DESIGN

- Aluminized steel primary heat exchanger with crimped non-welded construction
- AL29-4C Stainless steel secondary heat exchanger
- Non-welded crimped S-curve primary heat exchanger design for maximum durability

BURNERS

- Aluminized steel in shot burners for smooth ignition
- Isolated burner enclosure for quiet operation

CABINET CONSTRUCTION

- Compact 33" height
- Standardized widths for easy coil fit
- Unitized construction for cabinet integrity
- Heat exchanger compartment is insulated to increase efficiency and reduce sound levels
- Baked on pre painted steel cabinet finish

AIR DELIVERY SYSTEM

- Efficient ECM variable speed blower motor
- Motor features "soft start" and "soft stop" for quiet operation
- Active and passive dehumidification feature
- Easily removable slide-out blower design
- Dynamically balanced blower wheel with resilient motor mounts for smooth and quiet operation

CONTROLS

- Two stage gas valve
- Integrated ignition and fan control
- System Sentry™ control retains last five (5) fault codes with push button memory recall, regardless of power interruption
- Hot surface ignition system uses silicon nitride ignitor
- Control features 120 volt electronic air cleaner and humidifier terminals
- Control circuit is fuse protected
- Color coded control wiring
- Compatible with single or two stage thermostats for heating.
- Two stage thermostat is recommended when installed with two stage cooling unit.

WARRANTY

10 year limited parts warranty / lifetime heat exchanger warranty available. See limited warranty document for details.

California Only

*If installed in South Coast Air Quality Management District (SCAQMD) only:
This furnace does not meet the SCAQMD Rule 1111 NOx emission limit (14 ng/L).
This furnace is not eligible for the Clean Air Furnace Rebate Program: www.CleanAirFurnaceRebate.com.*

*If installed in San Joaquin Valley Air Pollution Control District (SJVAPCD) only:
This furnace does not meet the SJVAPCD Rule 4905 NOx emission limit (14 ng/L).*



MODEL NUMBER GUIDE

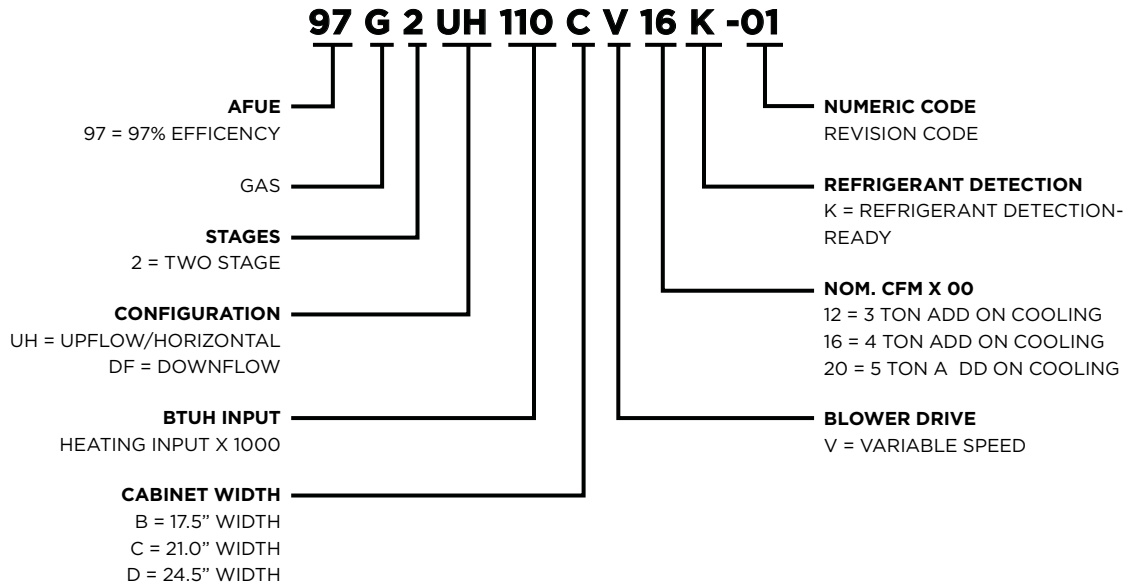

PHYSICAL AND ELECTRICAL DATA

	MODEL	1ST STAGE		2ND STAGE		AFUE (ICUS)	NOM. COOLING CAPACITY (TONS)	GAS INLET (IN.)	VOLTS/ HZ/ PHASE	MIN. TIME DELAY BREAKER OR FUSE	NOMINAL F.L.A.	TRANS. (V.A.)	APPROX. WEIGHT (LBS.)
		INPUT (BTUH)	OUTPUT (BTUH)	INPUT (BTUH)	OUTPUT (BTUH)								
UPFLOW/HORIZONTAL	97G2UH045BV12K	29,000	28,000	44,000	43,000	97.0	3	1/2	120-60-1	15	7.7	40	120
	97G2UH070BV12K	43,000	42,000	66,000	64,000	97.0	3	1/2	120-60-1	15	7.7	40	124
	97G2UH090CV12K	57,000	56,000	88,000	85,000	97.0	3	1/2	120-60-1	15	7.7	40	144
	97G2UH090CV20K	57,000	56,000	88,000	86,000	97.0	5	1/2	120-60-1	20	12.8	40	153
	97G2UH110CV20K	72,000	70,000	110,000	107,000	97.0	4	1/2	120-60-1	15	12.8	40	159
	97G2UH135DV20K	86,000	84,000	132,000	127,000	97.0	5	1/2	120-60-1	20	12.8	40	178
DOWNFLOW	97G2DF070BV16K	43,000	42,000	66,000	64,000	97.0	4	1/2	120-60-1	15	10.1	40	136
	97G2DF090CV20K	57,000	56,000	88,000	86,000	97.0	5	1/2	120-60-1	20	12.8	40	152
	97G2DF110CV20K	72,000	70,000	110,000	108,000	97.0	5	1/2	120-60-1	20	12.8	40	163

Note: For vent length and clearances to combustibles, please reference installation instructions.

FILTER REQUIREMENT DATA

Airflow Descriptor	Disposable Filters	Cleanable Filters
	Minimum Area (sq. in.)	Minimum Area (sq.in.)
12	576	288
16	768	384
20	960	480

1. The Airflow Descriptor is the two digits following the "B", "C", or "D" in the model number; e.g. "20" is the Airflow Descriptor.
 2. Areas shown for permanent filters are based on filters rated at 600 feet per minute face velocity.

BLOWER PERFORMANCE DATA - UPFLOW / HORIZONTAL

	MODEL	MOTOR SIZE (HP)	BLOWER SIZE	HEATING TEMP. RISE (°F)	HEATING CFM @ .10" - .80" W.C.				COOLING STAGE	COOLING CFM @ .10" - .80" W.C.				SPEED ADJUST.
					SETTING "D"	SETTING "C"	SETTING "B"	SETTING "A"		SETTING "D"	SETTING "C"	SETTING "B"	SETTING "A"	
UPFLOW / HORIZONTAL	97G2UH045BV12K	1/2	10x9	35-65 High Fire	745	875	990	1005	2nd Stage	905	1075	1210	1370	+
					685	765	895	910		815	980	1120	1255	Norm
					610	695	785	810		720	885	1020	1135	-
				20-50 Low Fire	685	765	895	910	1st Stage	595	760	865	980	+
					620	705	800	820		540	660	785	890	Norm
					545	625	715	725		485	600	695	790	-
	97G2UH070BV12K	1/2	10x9	50-80 High Fire	965	1060	1130	1255	2nd Stage	860	1060	1215	1365	+
					880	960	990	1140		810	960	1130	1265	Norm
					810	840	890	1030		705	840	1005	1140	-
				25-55 Low Fire	940	990	1070	1195	1st Stage	600	740	840	970	+
					830	895	965	1100		555	665	770	855	Norm
					755	825	840	975		500	600	680	790	-
	97G2UH090CV12K	1/2	10x9	60-90 High Fire	1060	1135	1240	1315	2nd Stage	875	1040	1210	1360	+
					960	1040	1120	1199		800	945	1100	1245	Norm
					830	935	980	1084		720	840	970	1115	-
				30-60 Low Fire	960	1040	1120	1206	1st Stage	625	710	830	950	+
					875	945	995	1100		565	670	760	860	Norm
					790	840	920	950		520	610	685	785	-
	97G2UH090CV20K	1	11x11	40-70 High Fire	1450	1565	1725	1865	2nd Stage	1385	1595	1820	2020	+
					1310	1450	1585	1690		1225	1465	1645	1885	Norm
					1155	1305	1450	1545		1065	1320	1504	1675	-
				25-55 Low Fire	1120	1265	1420	1520	1st Stage	935	1055	1275	1465	+
					965	1120	1285	1395		835	980	1120	1335	Norm
					865	950	1120	1235		740	870	1010	1150	-
97G2UH110CV20K	1	11x11	45-75 High Fire	1560	1760	1905	1955	2nd Stage	1310	1560	1745	1955	+	
				1415	1610	1740	1795		1220	1405	1570	1795	Norm	
				1285	1485	1560	1635		1075	1270	1430	1635	-	
			35-65 Low Fire	1155	1325	1420	1500	1st Stage	935	1065	1245	1405	+	
				1055	1200	1310	1360		865	970	1145	1280	Norm	
				935	1075	1170	1245		790	890	1025	1165	-	
97G2UH135DV20K	1	11x11	55-85 High Fire	1650	1845	2000	2055	2nd Stage	1395	1640	1840	2055	+	
				1495	1660	1880	1905		1290	1480	1660	1905	Norm	
				1360	1500	1670	1705		1170	1330	1500	1705	-	
			40-70 Low Fire	1300	1435	1630	1652	1st Stage	1015	1160	1330	1480	+	
				1190	1325	1465	1491		940	1085	1200	1345	Norm	
				1095	1190	1340	1343		870	965	1110	1225	-	

BLOWER PERFORMANCE DATA - DOWNFLOW

	MODEL	MOTOR SIZE (HP)	BLOWER SIZE	HEATING TEMP. RISE (°F)	HEATING CFM @ .10" - .80" W.C.				COOLING STAGE	COOLING CFM @ .10" - .80" W.C.				SPEED ADJUST.
					SETTING "D"	SETTING "C"	SETTING "B"	SETTING "A"		SETTING "D"	SETTING "C"	SETTING "B"	SETTING "A"	
DOWNFLOW	97G2DF070BV16K	3/4	11x10	35-65 High Fire	1110	1305	1430	1700	2nd Stage	1110	1340	1575	1800	+
					995	1175	1315	1520		995	1230	1420	1650	Norm
					880	1055	1170	1365		880	1085	1290	1460	-
				25-55 Low Fire	860	1020	1140	1340	1st Stage	740	915	1055	1255	+
					795	910	1030	1230		660	820	940	1120	Norm
					680	825	910	1085		575	735	850	995	-
	97G2DF090CV20K	1	11x11	40-70 High Fire	1395	1555	1695	1825	2nd Stage	1335	1600	1750	1980	+
					1275	1395	1585	1670		1225	1450	1630	1830	Norm
					1145	1265	1405	1525		1120	1270	1450	1660	-
				30-60 Low Fire	1130	1230	1365	1475	1st Stage	955	1115	1265	1450	+
					1040	1130	1250	1340		855	1005	1150	1285	Norm
					910	1025	1130	1210		750	890	1060	1170	-
	97G2DF110CV20K	1	11x11	45-75 High Fire	1595	1795	1955	2010	2nd Stage	1335	1585	1790	2010	+
					1450	1615	1795	1865		1220	1440	1630	1865	Norm
					1290	1460	1610	1680		1100	1275	1475	1680	-
35-65 Low Fire				1165	1305	1465	1547	1st Stage	920	1095	1265	1440	+	
				1055	1185	1315	1404		830	965	1130	1290	Norm	
				930	1070	1180	1272		735	860	1035	1155	-	

DIMENSIONS (IN.) - DOWNFLOW

	MODEL	A	B	C	D
DOWNFLOW	97G2DF070BV16K	17-1/2	16-3/8	16	15-1/2
	97G2DF090CV20K	21	19-7/8	19-1/2	19
	97G2DF110CV20K	21	19-7/8	19-1/2	19

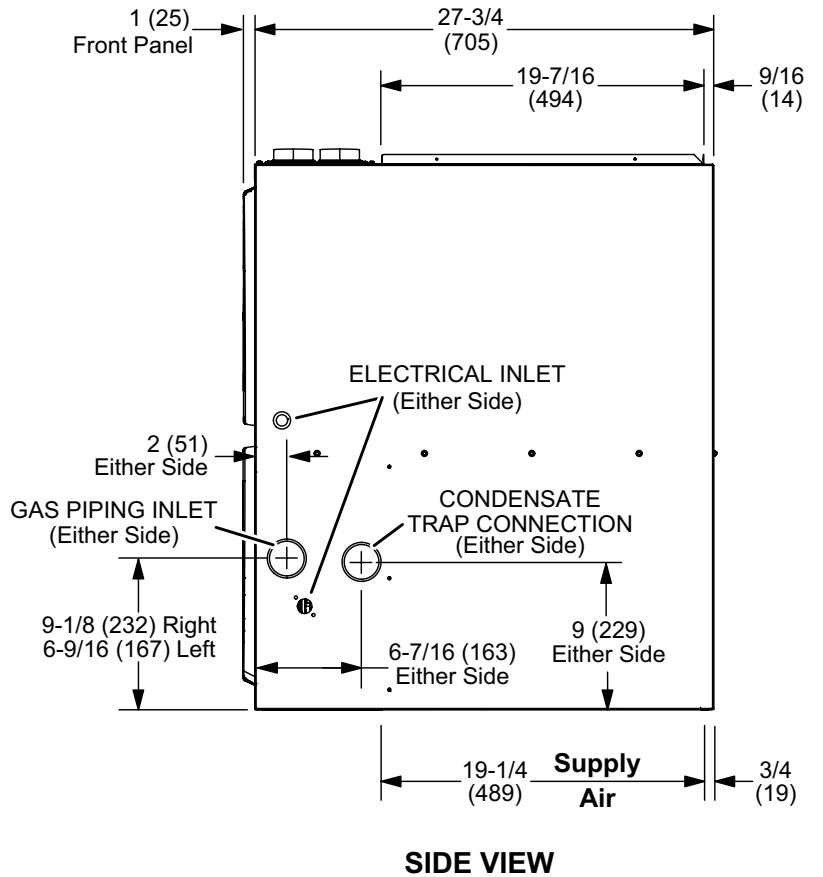
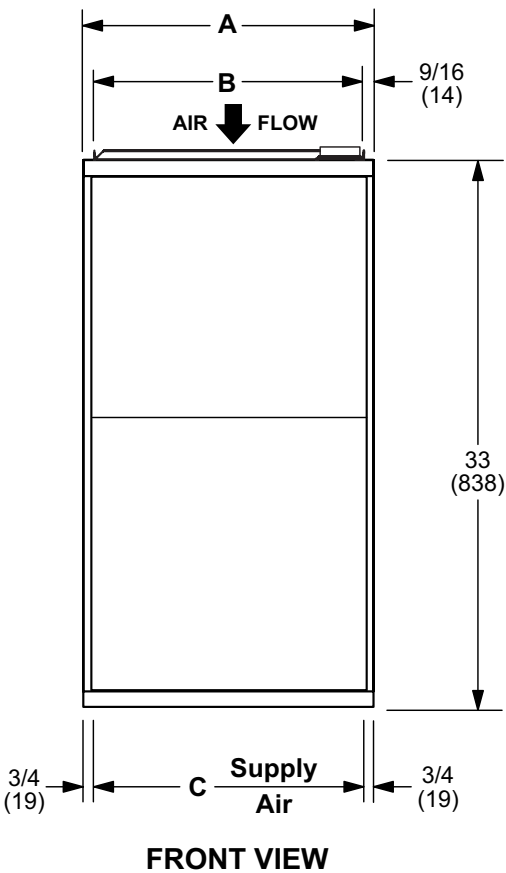
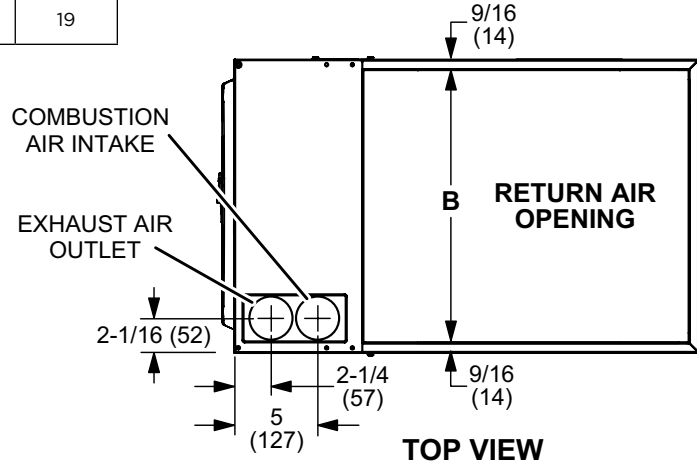

ACCESSORY LIST

CATALOG NUMBER	DESCRIPTION
EXTERNAL FILTER RACK KITS	
1.841018	1 PACK (16 X 25)
1.841039	10 PACK (16 X 25)
NATURAL TO LP KITS	
11K48	2-STAGE - 90
11K47	HIGH ALTITUDE 2-STAGE (>4500FT.)
RETURN AIR BASE	
68W62	17.5" B WIDTH
68W63	21.0" C WIDTH
68W64	24.5" D WIDTH
DOWNFLOW COMBUSTIBLE FLOORING BASE	
11M60	17.5" B WIDTH
11M61	21.0" C WIDTH
NIGHT SERVICE KITS	
84W50	TWO STAGE
HORIZONTAL SUSPENSION KIT	
51W10	80% & 90% KIT
FLUSH MOUNT TERMINATION (90% FURNACES ONLY) US ONLY	
51W11	2" & 3" VENT VERSION
CONCENTRIC VENT KIT (90% FURNACES ONLY) US ONLY	
71M80	1-1/2" VENT VERSION
69M29	2" VENT VERSION
60L46	3" VENT VERSION
CONCENTRIC VENT KIT (90% FURNACES ONLY) CANADA	
44W92	1-1/2" AND 2" VENT VERSION
44W93	3" VENT VERSION
Transformer (75VA)	
Recommended when furnace is used with zoning or defrost thermostats and other 24V accessories requiring a higher VA rating	27J32
Circuit breaker (furnished) is wired in series	
Replaces the standard 40VA transformer	

For vent length and clearances to combustibles, please reference installation instructions.

REFRIGERANT DETECTION SYSTEM (RDS) COMPONENTS

Description	Order No.
Refrigerant Detection System (RDS) Coil Sensor Kit	27V53



1-800-448-5872

All specifications and illustrations subject to change without notice and without incurring obligations.