

RHP13

PRODUCT SPECIFICATIONS

13 SEER HEAT PUMP RESIDENTIAL PACKAGED UNIT

FORM NO. RHP13-100 (06/2014)

REFRIGERANT SYSTEM

- Environmentally friendly R410A refrigerant
- Copper tubing with enhanced fin coils
- External service gauge ports

CABINET CONSTRUCTION

- Low profile, with compact footprint
- Insulation to minimize heat loss plus reduce sound
- Baked on pre-painted steel cabinet finish
- Easy service access
- Wire grill protection
- One piece "no leak" top design

BLOWER

- Insulated compartment to reduce sound
- High efficiency multispeed motor for wide airflow range

CONTROLS

- Integrated control with L.E.D. diagnostics
- Defrost control board with field selectable time intervals
- High and low refrigerant pressure switches for system protection

INSTALLATION

- Full perimeter base rail system for easy installation
- Horizontal or down discharge, duct covers provided
- Utility connections on "right side"
- Filter channels for 1" filter field provided

WARRANTY

10 year limited parts and compressor warranty. See limited warranty document for details.



Model Number Guide

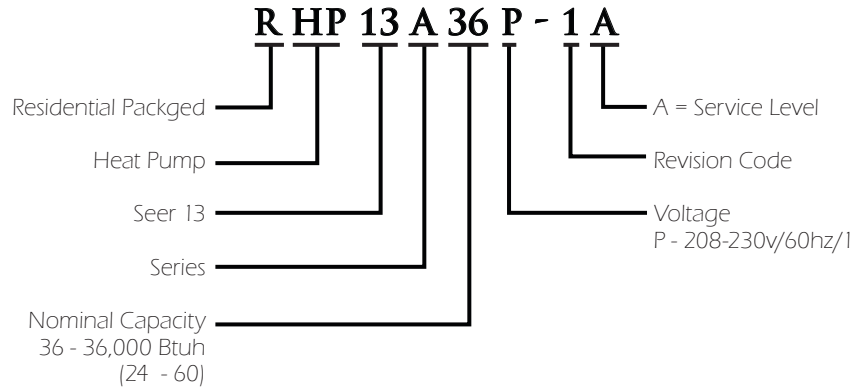

Electrical and Physical Data

Model	Voltage/HZ/ Phase	Voltage Range	Min. Circuit Amp.	Max. Over Current Device (amps)	Compressor		Condenser Fan Motor			Indoor Blower Motor		Refrig. Charge	Shipping Weight (lbs.)
					Rated Load (amps)	Locked Rotor (amps)	Rated Load (amps)	Rated HP	Nom. RPM	Rated Load (amps)	Rated HP		
RHP13A24P	208-230/60/1	197-253	21.3	30	12.8	58.3	1.2	1/4	1075	4.1	1/2	80	338
RHP13A30P	208-230/60/1	197-253	21.3	30	12.8	64	1.2	1/4	1075	4.1	1/2	115	365
RHP13A36P	208-230/60/1	197-253	26.1	35	16.6	79	1.2	1/4	1075	4.1	1/2	118	365
RHP13A42P	208-230/60/1	197-253	30.4	45	18.3	112	1.7	1/3	1075	5.8	3/4	142	462
RHP13A48P	208-230/60/1	197-253	34.7	50	21.8	117	1.7	1/3	1075	5.8	3/4	154	470
RHP13A60P	208-230/60/1	197-253	40.5	60	26.4	134	1.7	1/3	1075	5.8	3/4	150	470

Performance

Model	Cooling					Heating				
	SEER	EER	Rated AHRI Capacity ¹ BTUH	Rated Sensible Capacity Btuh	CFM	47°		HSPF	17°	
						BTUH	COP		BTUH	COP
RHP13A24P	13.0	11.0	23,000	17,000	800	21,600	3.5	7.7	13,000	2.2
RHP13A30P	13.0	11.0	28,000	21,000	1000	27,000	3.5	7.7	16,000	2.3
RHP13A36P	13.0	11.0	34,600	25,600	1200	33,600	3.5	7.7	20,200	2.3
RHP13A42P	13.0	11.0	40,000	30,400	1450	39,000	3.4	7.7	22,400	2.2
RHP13A48P	13.0	11.0	46,000	35,000	1600	44,000	3.3	7.7	26,800	2.1
RHP13A60P	13.0	10.5	56,000	39,200	1800	54,000	3.3	7.7	34,000	2.3

Blower Performance

Model	Blower Tap	CFM @ ext. Static Pressure in inches wc without filter, dry coil						
		0.2	0.3	0.4	0.5	0.6	0.7	0.8
RHP13A24P	1	640	460	370	---	---	---	---
	2	830	800	760	710	640	600	570
	3	950	910	880	840	800	750	700
	4	900	870	830	800	730	690	640
	5	1060	1030	980	960	930	910	860
RHP13A30P	1	650	550	490	430	---	---	---
	2	1030	1000	970	930	900	860	820
	3	1150	1110	1080	1050	1010	980	960
	4	1110	1070	1040	1000	970	950	920
	5	1150	1110	1080	1050	1010	980	960
RHP13A36P	1	650	590	500	430	---	---	---
	2	1240	1200	1150	1100	1060	1020	980
	3	1320	1260	1230	1200	1160	1120	1080
	4	1240	1200	1150	1100	1060	1020	980
	5	1320	1260	1230	1200	1160	1120	1080
RHP13A42P	1	780	690	610	540	---	---	---
	2	1450	1370	1280	1200	1120	1060	990
	3	1650	1570	1510	1440	1360	1260	1160
	4	1510	1430	1380	1290	1220	1150	1090
	5	1650	1570	1510	1440	1360	1260	1160
RHP13A48P	1	860	760	690	640	---	---	---
	2	1650	1600	1550	1500	1440	1370	1290
	3	1800	1750	1690	1630	1570	1470	1330
	4	1650	1600	1550	1500	1440	1370	1290
	5	1800	1750	1690	1630	1570	1470	1330
RHP13A60P	1	1000	900	800	750	---	---	---
	2	1820	1790	1730	1670	1630	1530	1380
	3	1950	1910	1860	1800	1700	1560	1360
	4	1820	1790	1730	1670	1630	1530	1380
	5	1950	1910	1860	1800	1700	1560	1360

Subtract .10 Duct Static for Downflow CFM

Taps 4 & 5 are used with Electric Heat. Refer to Heater Label on unit for proper Heat Tap selection

Heating Performance Extended Ratings

Model	Outdoor Temp - DB/WB °F									
	0/0		17/15		35/33		47/43		62/56	
	Btuh	kW	Btuh	kW	Btuh	kW	Btuh	kW	Btuh	kW
RHP13A24P	10,100	1.71	13,000	1.73	15,400	1.71	21,600	1.80	26,200	1.87
RHP13A30P	10,700	2.03	16,000	2.04	21,100	2.14	27,000	2.26	32,700	2.33
RHP13A36P	15,900	2.53	20,200	2.58	24,900	2.66	33,600	2.82	40,200	2.93
RHP13A42P	20,000	2.92	23,200	3.10	27,800	3.24	39,000	3.36	46,800	3.50
RHP13A48P	23,900	3.57	26,800	3.74	29,300	3.73	44,000	3.91	52,900	4.08
RHP13A60P	25,200	4.30	34,000	4.34	41,200	4.32	54,000	4.78	64,800	5.03

Cooling Performance Extended Ratings

Model	Indoor Temp DB/WB °F	Outdoor Temp - DB°F														
		65°			82°			95°			105°			115°		
		Btuh	S/T	kW	Btuh	S/T	kW	Btuh	S/T	kW	Btuh	S/T	kW	Btuh	S/T	kW
RHP13A24P	85/72	28,100	0.59	1.60	26,500	0.62	1.89	25,300	0.65	2.10	23,700	0.68	2.33	21,800	0.71	2.31
	80/67	26,500	0.67	1.59	25,000	0.70	1.85	23,000	0.74	2.09	21,400	0.76	2.31	19,100	0.81	2.30
	75/63	25,000	0.71	1.58	22,600	0.74	1.87	20,700	0.76	2.08	19,100	0.81	2.30	17,100	0.85	2.29
	75/57	23,100	1.00	1.56	21,600	1.00	1.84	20,500	1.00	2.05	18,800	1.00	2.27	16,900	1.00	2.25
RHP13A30P	85/72	33,700	0.61	1.97	31,900	0.64	2.30	30,500	0.67	2.56	28,200	0.70	2.84	25,900	0.73	2.82
	80/67	32,100	0.68	1.96	29,900	0.72	2.27	28,000	0.75	2.55	25,700	0.79	2.81	22,500	0.84	2.79
	75/63	30,200	0.72	1.95	27,400	0.76	2.28	25,200	0.79	2.53	22,600	0.84	2.79	19,900	0.88	2.77
	75/57	27,900	1.00	1.92	26,200	1.00	2.25	24,900	1.00	2.50	22,500	1.00	2.76	20,000	1.00	2.73
RHP13A36P	85/72	41,800	0.61	2.39	39,400	0.63	2.82	37,500	0.65	3.15	35,700	0.68	3.50	33,100	0.70	3.49
	80/67	39,400	0.68	2.37	37,500	0.71	2.80	34,600	0.74	3.14	32,000	0.76	3.47	29,500	0.80	3.43
	75/63	37,100	0.72	2.36	33,900	0.75	2.79	31,500	0.77	3.12	29,400	0.82	3.45	26,200	0.86	3.42
	75/57	34,300	1.00	2.32	32,300	1.00	2.75	30,800	1.00	3.08	28,900	1.00	3.40	26,100	1.00	3.36

Heat Strip Electric

Model No.	Heater Model	Unit Supply Single Phase	Heater kW	Minimum Circuit Ampacity 1	Maximum Fuse / HACR Brkr. 2 1	Minimum Circuit Ampacity 2	Maximum Fuse / HACR Brkr. 2 2
RHP13A24P RHP13A30P RHP13A36P	AHSA05A	240	5.0	31.2	35	----	---
		208	3.7	27.8	30	----	---
	AHSA07A	240	7.0	41.7	50	----	---
		208	5.3	36.8	40	----	---
	AHSA010A	240	10.0	57.3	60	----	---
		208	7.5	50.3	60	----	---
AHSA015A	240	15.0	57.3	60	26	30	
	208	11.3	50.3	60	22.5	25	
RHP13A42P RHP13A48P RHP13A60P	AHSA05A	240	5.0	33.3	35	----	---
		208	3.7	29.9	30	----	---
	AHSA07A	240	7.0	43.8	50	----	---
		208	5.3	38.9	40	----	---
	AHSA010A	240	10.0	59.4	60	----	---
		208	7.5	52.4	60	----	---
	AHSA015A	240	15.0	59.4	60	26	30
		208	11.3	52.4	60	22.5	25
	AHSA20A	240	20.0	59.4	60	52.1	60
		208	15.0	52.4	60	45.1	50

Field Provided 1" Filter Dimensions

Small Base	2, 2.5, 3 Ton	24" width 28" height
Large Base	3.5, 4, 5 Ton	30" width 30" height

Sound Ratings

Model No.	Sound dBA
RHP13A24P	77
RHP13A30P	77
RHP13A36P	77
RHP13A42P	80
RHP13A48P	80
RHP13A60P	80

Accessories

Description	Where Used	Kit Number
5 kW Electric Heater	All Models	AHSA05A-1
7 kW Electric Heater	All Models	AHSA07A-1
10 kW Electric Heater	All Models	AHSA10A-1
15 kW Electric Heater	All Models	AHSA15A-1
20 kW Electric Heater	42, 48 & 60	AHSA20A-1
Roof Curb	24, 30 & 36	ACURB161-1
Roof Curb	42, 48 & 60	ACURB163-1
Manual Fresh Air Damper	24, 30, 36	ADMPR145-1
Manual Fresh Air Damper	42, 48, 60	ADMPR166-1
Motorized Fresh Air Damper	24, 30, 36	ADMPR146-1
Motorized Fresh Air Damper	42, 48, 60	ADMPR167-1
Downflow Economizer	24, 30, 36	AECON825-1
Downflow Economizer	42, 48, 60	AECON826-1
Horizontal Economizer	24, 30, 36	AECON827-1
Horizontal Economizer	42, 48, 60	AECON828-1

Dimensions (in.)

Model No.	A	B	C	D	E	F
RHP13-24	32-1/2	46-1/2	46-1/2	45-5/8	45-5/8	17-1/2
RHP13-30						
RHP13-36						
RHP13-42	34-1/2	55-1/2	50-1/2	54-5/8	49-5/8	21-1/2
RHP13-48						
RHP13-60						

Model No.	G	H	J	K	L
RHP13-24	11-1/2	5-1/2	1-5/8	4	4
RHP13-30					
RHP13-36					
RHP13-42	12	5-1/2	1-5/8	6-1/4	5-5/8
RHP13-48					
RHP13-60					

Model No.	M	N	P	Q	R
RHP13-24	1-3/4	15-5/8	27-3/4	24-7/8	9-3/4
RHP13-30					
RHP13-36					
RHP13-42	2-3/8	17-1/8	29-3/4	26-7/8	15-1/2
RHP13-48					
RHP13-60					

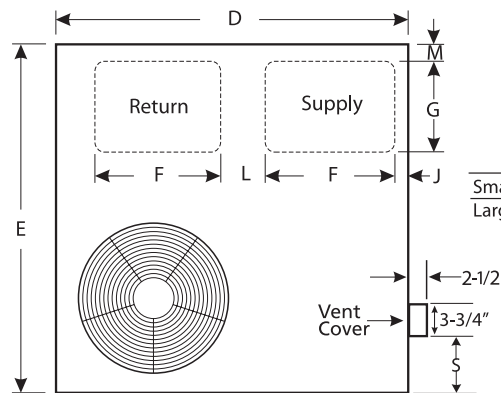
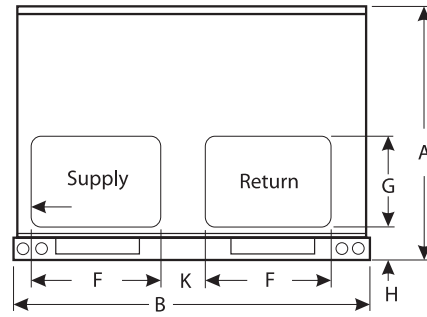

	S
Small Base	4-1/8"
Large Base	5-1/4"

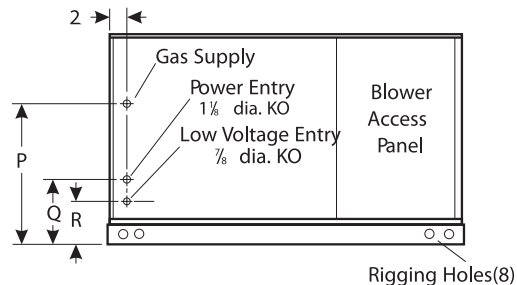
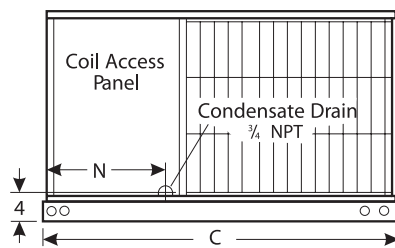

Accessories Dimensions inches (mm)

ECONOMIZER DAMPERS - DOWNFLOW

For 24, 30 and 36 Models

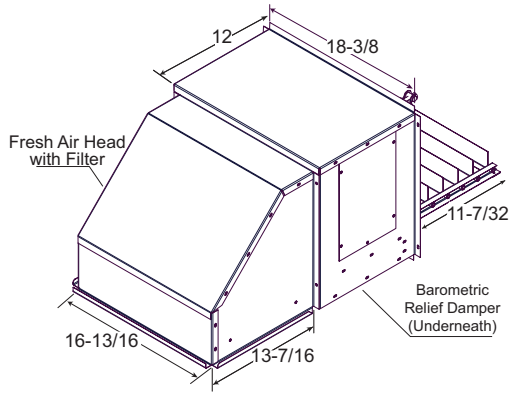

For 42, 48 and 60 Models

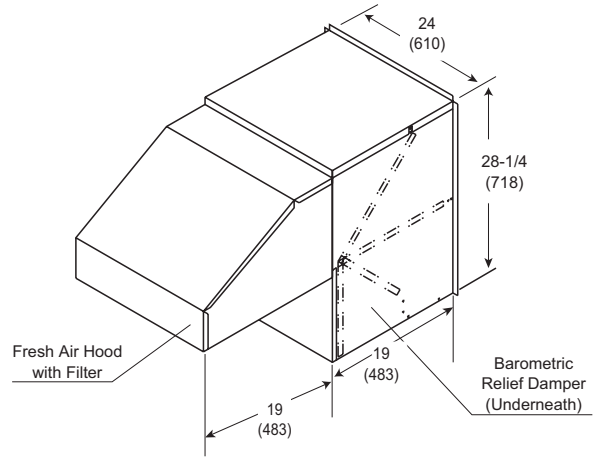

ECONOMIZER DAMPERS - HORIZONTAL

Model No.	A		B	
	in	mm	in	mm
RHP13A 24, 30, 36	17-5/8	448	11-1/2	292
RHP13A 42, 48, 60	21-3/4	552	12-1/4	311

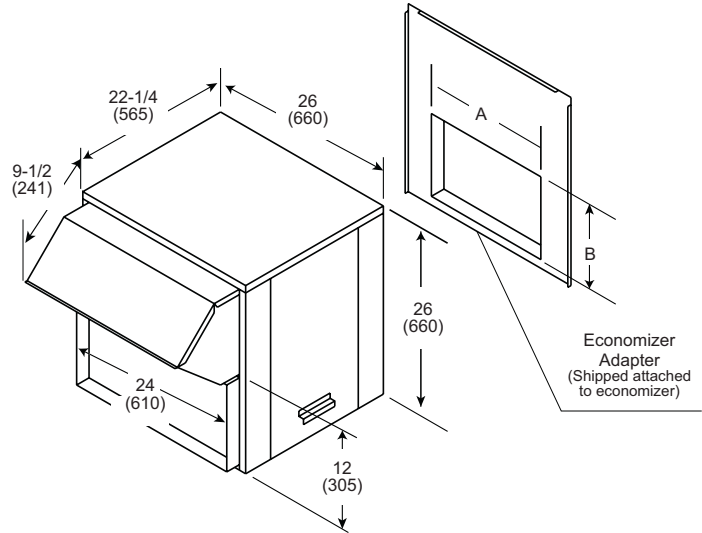

FRESH AIR DAMPERS

Manual

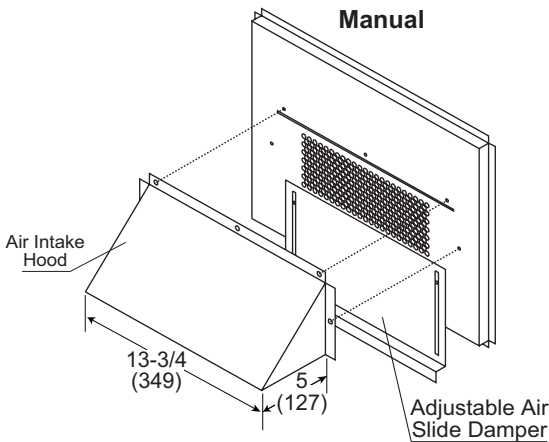

Motorized

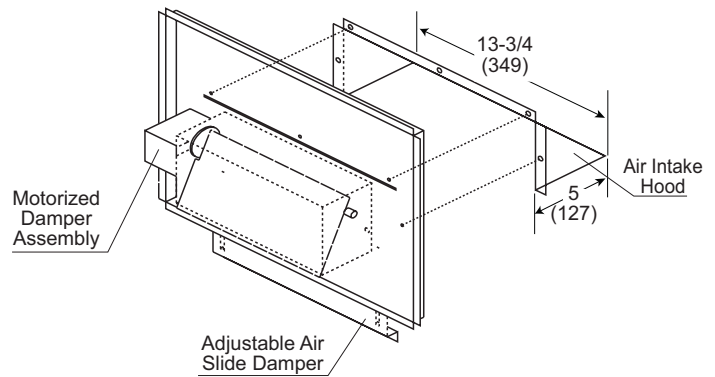

Accessories Dimensions inches (mm)

ROOF CURB

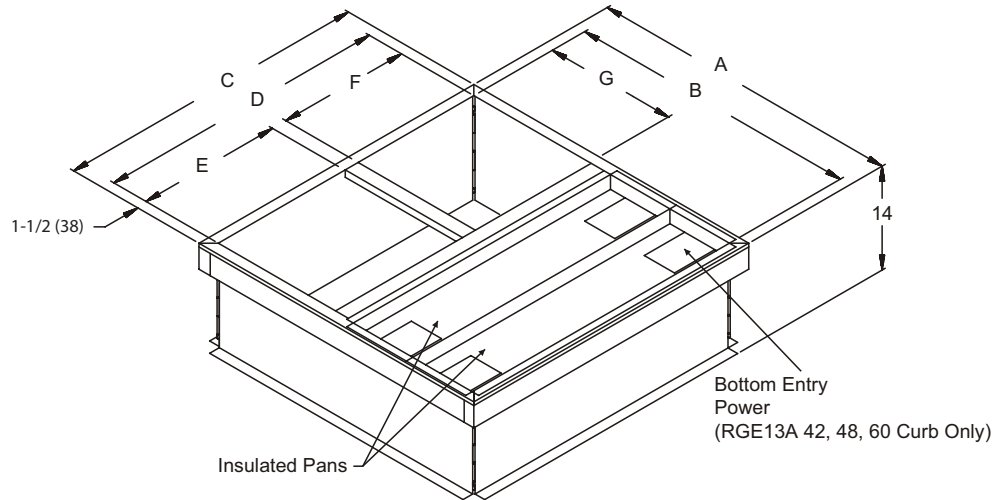

Model No.	A		B		C		D		E		F	
	in	mm	in	mm	in	mm	in	mm	in	mm	in	mm
RHP13A24, 30, 36	40	1016	40	1016	17-1/2	445	20	508	18	457	20	508
RHP13A42, 48, 60	44-1/8	1121	49	1245	18	457	23-1/2	597	23-1/2	597	20-1/2	521

Revisions		
Section	Page #	Description
Performance	2	Rating tables revised



1-800-448-5872

All specifications and illustrations subject to change without notice and without incurring obligations.