

# 7AC17T

Two-Stage | Omniguard® Coil | R-454B | 1-Phase | 60Hz

RESIDENTIAL  
PRODUCT SPECIFICATIONS

2 to 5 Tons  
SEER2 up to 17.9  
Cooling Capacity | 24,000 to 60,000 Btuh



## MODEL NUMBER IDENTIFICATION

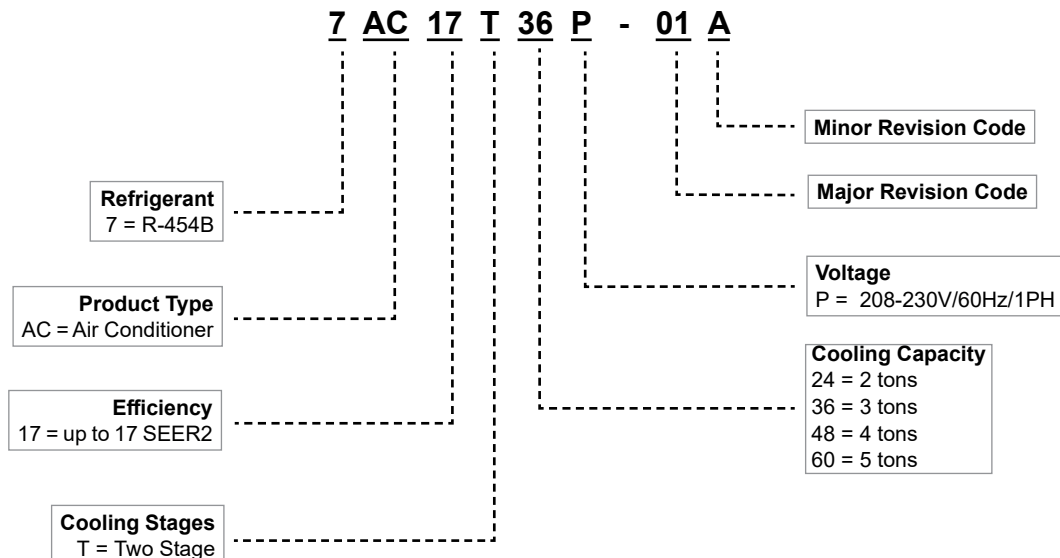

## FEATURE HIGHLIGHTS

- Outdoor Coil Fan
- Omniguard® Coil
- High Pressure Switch
- Low Pressure Switch
- Two-Stage Scroll Compressor
- Heavy Gauge Steel Cabinet
- Louvered Steel Panels
- Refrigerant Line Connections and Access

## CONTENTS

Model Number Identification . . . . .	1
Approvals and Warranty . . . . .	3
Features . . . . .	3
Specifications . . . . .	6
Electrical Data . . . . .	6
Optional Accessories - Order Separately . . . . .	6
Dimensions - Unit . . . . .	7
Sound Data . . . . .	8
Field Wiring . . . . .	8
Installation Clearances . . . . .	9
TXV Substitution - R-454B . . . . .	10
TXV Usage . . . . .	10

## APPROVALS AND WARRANTY

### **APPROVALS**

- AHRI Standard 210-240-2023 certified
- AHRI Certified system match-ups and expanded ratings, visit [www.alliedratings.com](http://www.alliedratings.com)
- ENERGY STAR® Certified
- Sound rated to AHRI Standard 270-2008 test conditions
- Rated According to U.S. Department of Energy (DOE) test procedures
- Unit and components ETL, NEC and CEC bonded for grounding to meet safety standards for servicing
- ETL certified (U.S. and Canada)
- ISO 9001 Registered Manufacturing Quality System

### **WARRANTY**

- 10-years limited warranty on all parts, extended warranty available.
- Coverage (Standard 5-year limited parts warranty plus an additional 5-year limited extended parts warranty).
- Warranty must be registered online within 60 days of installation to qualify for 10-year coverage.
- Unregistered equipment defaults to 5-year coverage.
- See full warranty at [www.alliedair.com](http://www.alliedair.com) for terms, conditions, and exclusions.

## FEATURES

### **APPLICATIONS**

- 2 through 5 ton
- Sound levels as low as 73 dBA
- Single phase power supply
- Applicable to indoor air handlers or gas furnaces with indoor add-on coils
- Shipped completely factory assembled, piped and wired

### **REFRIGERATION SYSTEM**

#### **R-454B Refrigerant**

- Low GWP (Global Warming Potential)
- Zero ODP (Ozone Depletion Potential)
- Low Toxicity/Lower Flammability - A2L
- Unit is factory pre-charged

#### **Outdoor Coil Fan**

- Direct drive fan
- Vertical air discharge
- Sleeve bearings
- Inherently protected
- Totally enclosed fan motor
- ECM motor (060 model)
- Louvered steel top fan guard

#### **OmniGuard® Coil**

- Enhanced aluminum alloy tube/enhanced fin coil
- Superior corrosion resistance
- Ripple-edged aluminum fins
- Aluminum tube construction
- Lanced fins for maximum fin surface exposure
- Fin collars grip tubing for maximum contact area
- Flared shoulder tubing connections
- Factory tested under high pressure
- Entire coil is accessible for cleaning

#### **High Pressure Switch**

- Protects the system from high pressure conditions that can be a result of fan failure or a blocked/dirty coil
- Automatic reset

#### **Low Pressure Switch**

- Shuts off unit if suction pressure falls below setting
- Provides loss of charge and freeze-up protection
- Automatic reset

#### **High-Capacity Liquid Line Drier**

- Furnished for field installation
- Drier traps moisture or dirt that could contaminate the system
- 100% molecular-sieve, bead type, drier

## FEATURES

### REFRIGERATION SYSTEM (continued)

#### Optional Accessories

##### Expansion Valve Kits

- Field installed on indoor units (if required)
- See TXV Usage table
- Chatleff style fitting

##### Freezestat

- Senses suction line temperature
- Cycles compressor off when suction line temperature falls below freezestat setpoint
- Opens at 29°F and closes at 58°F
- Installs on or near the discharge line of the evaporator or on the suction line

### INDOOR REFRIGERANT DETECTION SYSTEM (RDS)

- Complies with UL 60335-2-40 approved standard
- Required for all systems using R-454B refrigerant
- Factory or field installed on all indoor units
- Consists of a RDS refrigerant detection sensor and a mitigation control in the indoor unit
- Ensures safe operation for systems equipped with R-454B refrigerant
- Indoor sensor will detect any R-454B refrigerant
- If R-454B refrigerant is detected, the refrigerant detection system will stop compressor operation and operate the blower to reduce concentrations in the conditioned space
- Once safe levels are reached the HVAC system will resume normal operation
- Refer to indoor unit Product Specifications documents for additional details

### COMPRESSOR

#### Two-Stage Scroll Compressor

- High volumetric efficiency
- Uniform suction flow
- Constant discharge flow
- Quiet operation

#### Compressor Operation

- Two involute spiral scrolls matched together generate a series of crescent shaped gas pockets between them
- During compression, one scroll remains stationary while the other scroll orbits around it



- Gas is drawn into the outer pocket, the pocket is sealed as the scroll rotates
- As the spiral movement continues, gas pockets are pushed to the center of the scrolls
- Volume between the pockets is simultaneously reduced
- When the pocket reaches the center, gas is now at high pressure and is forced out of a port located in the center of the fixed scrolls
- During compression, several pockets are compressed simultaneously resulting in a smooth continuous compression cycle
- Continuous flank contact, maintained by centrifugal force, minimizes gas leakage and maximizes efficiency
- Compressor is tolerant to the effects of slugging and contaminants
- If this occurs, scrolls separate, allowing liquid or contaminants to be worked toward the center and discharged
- During the compression process, there are several pockets in the scroll that are compressing gas
- Modulation is achieved by venting a portion of the gas in the first suction pocket back to the low side of the compressor thereby reducing the effective displacement of the compressor
- A 24-volt DC solenoid valve inside the compressor controls staging
- When the 3-way solenoid is energized it moves the lift ring assembly to block the ports and the compressor operates at full-load or 100% capacity
- When the solenoid is de-energized the lift ring assembly moves to unblock the compressor ports and the compressor operates at part-load or approximately 67% of its full-load capacity
- The “loading” and “unloading” of the two stage scroll is done “on the fly” without shutting off the single-speed compressor motor between stages
- Low gas pulses during compression reduces operational sound levels
- Compressor motor is internally protected from excessive current and temperature
- Compressor is installed in the unit on specially formulated, resilient rubber mounts for better sound dampening and vibration free operation

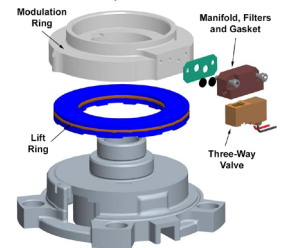

#### Compressor Crankcase Heater (-060 models)

- Prevents liquid refrigerant migration into compressor and ensures proper compressor lubrication

## FEATURES

### **COMPRESSOR (Continued)**

#### **Optional Accessories**

#### **Compressor Crankcase Heater (024-036-048 models)**

- Prevents liquid refrigerant migration into compressor and ensures proper compressor lubrication

#### **Compressor Hard Start Kit**

- Single-phase units are equipped with a PSC compressor motor
- This type of motor normally does not need a potential relay and start capacitor
- In conditions such as low voltage, kit may be required to increase the compressor starting torque

**NOTE** - Hard start kit is required in applications where the supply voltage is less than 230V.

#### **Compressor Low Ambient Cut-Off**

- Non-adjustable switch (low ambient cut-out)
- Prevents compressor operation when outdoor temperature is below 35°F

#### **Compressor Sound Cover**

- Reinforced vinyl compressor cover
- 1-1/2 inch thick batt fiberglass insulation
- All open edges are sealed with a one-inch wide hook and loop fastening tape

#### **Compressor Time-Off Control**

- Kit prevents compressor short-cycling and allows time for suction and discharge pressure to equalize
- Permits compressor start-up in an unloaded condition
- Automatic reset with 5 minute delay between compressor shut-off and start-up

### **CABINET**

- Heavy-gauge steel construction
- Pre-painted powder paint cabinet finish
- Louvered heavy gauge steel panels surround unit on all four sides
- Control box is conveniently located with all controls factory wired
- Corner patch plate allows access to compressor components
- Drainage holes are provided in base section for moisture removal

#### **Zinc-Coated Steel Unit Base**

- Resists rust and corrosion

#### **Refrigerant Line Connections, Electrical Inlets and Service Valves**

- Sweat connection suction and liquid lines
- Located on corner of unit cabinet
- Suction valve can be fully shut off, while liquid valve may be front seated to manage refrigerant charge while servicing system
- Refrigerant line connections and field wiring inlets are located in one central area of the cabinet
- See dimension drawing

#### **Braze-Free/Press Fitting Flexibility**

- Units can accommodate braze-free or press fittings for installation versatility

#### **Optional Accessories**

#### **Unit Stand-Off Kit**

- Black high density polyethylene feet are available to raise unit off of mounting surface away from damaging moisture
- Four feet are furnished per order number

### **CONTROLS**

#### **Optional Accessories**

#### **Blower Relay Kit (for use with furnaces equipped with constant torque blower motors)**

- Allows furnace blower speed changes when matched with two-stage air conditioners

#### **Indoor Blower Off Delay Relay**

- Delays the indoor blower-off time during the cooling cycle

#### **Indoor Blower Speed Relay**

- Relay kit provides the option of changing blower speeds on standard permanent split capacitor (PSC) multi-tap blower motors during cooling operation
- Provides optimum humidity control conditions by automatically reducing indoor blower speed during continuous fan operation or low stage compressor operation to reduce humidity levels

#### **Low Ambient Kit**

- Air conditioners can operate down to 45°F outdoor air temperature without additional controls
- Allows unit to operate properly down to 30°F

**NOTE** - Crankcase heater and freezestat should be installed on compressors equipped with a low ambient kit.

**NOTE** - A Compressor Low Ambient Cut-Off Switch should be added to terminate compressor operation below recommended operation conditions.

## SPECIFICATIONS

Size		024	036	048	060	
<b>Nominal Tonnage</b>		2	3	4	5	
<b>Sound Rating Number</b>	dBA	75	73	74	75	
<b>Connections</b>	Liquid line (OD) - in.	3/8	3/8	3/8	3/8	
	(Sweat) Suction line (OD) - in.	3/4	7/8	7/8	1-1/8	
<b>Compressor Type</b>		2-Stage Scroll	2-Stage Scroll	2-Stage Scroll	2-Stage Scroll	
<b>Refrigerant (15 ft. Line Set)</b>	<sup>1</sup> R-454B charge furnished	6 lbs. 4 oz.	6 lbs. 8 oz.	7 lbs. 14 oz.	9 lbs. 5 oz.	
<b>Refrigerant (30 ft. Line Set)</b>	<sup>1</sup> R-454B charge furnished	6 lbs. 13 oz.	7 lbs. 1 oz.	8 lbs. 7 oz.	9 lbs. 14 oz.	
<b>Indoor Unit Expansion Valve (TXV)</b>		<b>26Z70</b>	<b>26Z70</b>	<b>26Z71</b>	<b>26Z72</b>	
<b>Outdoor Coil</b>	Net face area - ft. <sup>2</sup>	Outer coil	16.33	16.33	16.33	24.93
		Inner coil	15.75	15.75	15.75	24.13
	Tube diameter - in.	5/16	5/16	5/16	5/16	
	Rows	2	2	2	2	
	Fins - in.	22	22	22	22	
<b>Outdoor Fan</b>	HP	1/6	1/8	1/6	1/4	
	Diameter - in.	22	22	22	22	
	Blades	3	3	3	3	
	Cfm	2960	2890	3200	3620	
	Rpm	825	825	825	825	
	Watts	200	165	240	265	
<b>Shipping Data - lbs.</b>		185	188	206	246	

## ELECTRICAL DATA

Line voltage data (Volts-Phase-Hz)	208/230-1-60	208/230-1-60	208/230-1-60	208/230-1-60	
<sup>2</sup> Maximum overcurrent protection (MOCP) amps	20	30	40	50	
<sup>3</sup> Minimum circuit ampacity (MCA)	13.8	18.9	23.9	33.2	
<b>Compressor</b>	Rated load amps	10.3	14.6	18.3	25.2
	Locked rotor amps	62	90	138	147.3
<b>Fan Motor</b>	Full load amps	1	0.74	1	1.7
	Locked rotor amps	1.9	1.65	1.9	3.2

## OPTIONAL ACCESSORIES - ORDER SEPARATELY

<b>Compressor Crankcase Heater</b>	<b>27V63</b>	•	•		
	<b>27P59</b>			•	
<b>Compressor Hard Start Kit</b>	Copeland <b>10J42</b>	•	•	•	
	<b>28V41</b>				•
<b>Compressor Low Ambient Cut-Off Switch</b>	<b>45F08</b>	•	•	•	•
<b>Compressor Sound Cover</b>	<b>18J42</b>	•	•	•	•
<b>Compressor Timed-Off Control</b>	<b>47J27</b>	•	•	•	•
<b>Freezestat</b>	3/8 in. <b>93G35</b>	•	•	•	•
<b>Indoor Blower Off Delay Relay</b>	<b>58M81</b>	•	•	•	•
<b>Loss of Charge Switch Kit</b>	<b>84M23</b>	•	•	•	•
<b><sup>4</sup> Low Ambient Kit (Fan Cycling)</b>	<b>34M72</b>	•	•	•	•
<b>Unit Stand-Off Kit</b>	<b>94J45</b>	•	•	•	•

NOTE - Extremes of operating range are plus 10% and minus 5% of line voltage.

<sup>1</sup> Refrigerant charge sufficient for the line set length listed in parenthesis. For longer line set requirements see the Installation Instructions or unit Charging Label for information about line set length and additional refrigerant charge required.

<sup>2</sup> HACR type breaker or fuse.

<sup>3</sup> Refer to National or Canadian Electrical Code manual to determine wire, fuse and disconnect size requirements.

<sup>4</sup> Crankcase Heater and Freezestat are recommended with Low Ambient Kit.

# DIMENSIONS - UNIT

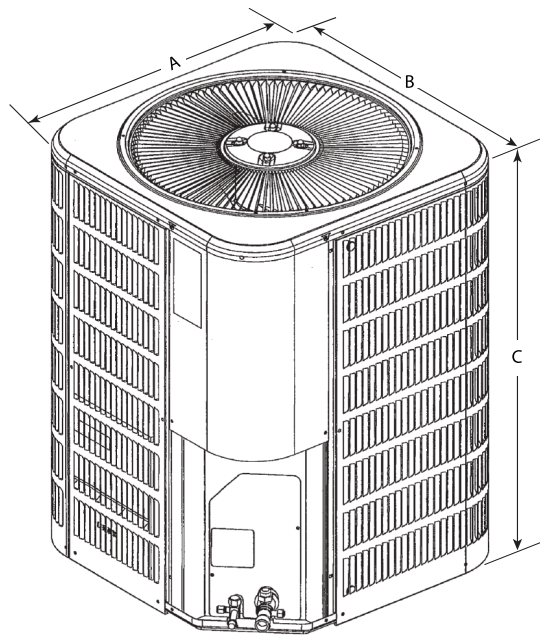
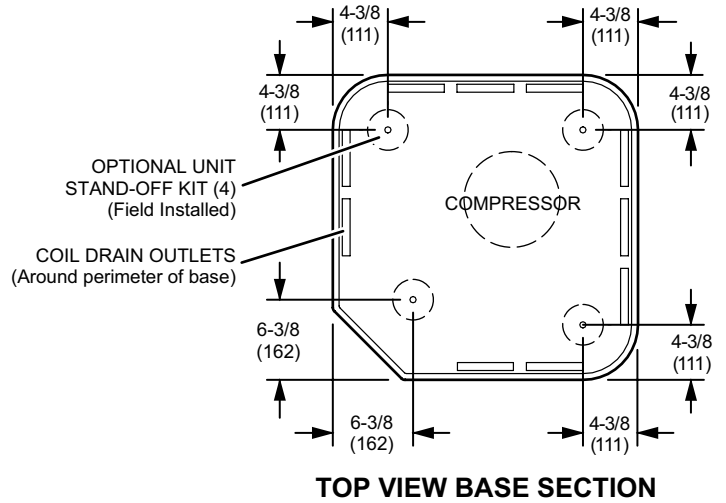
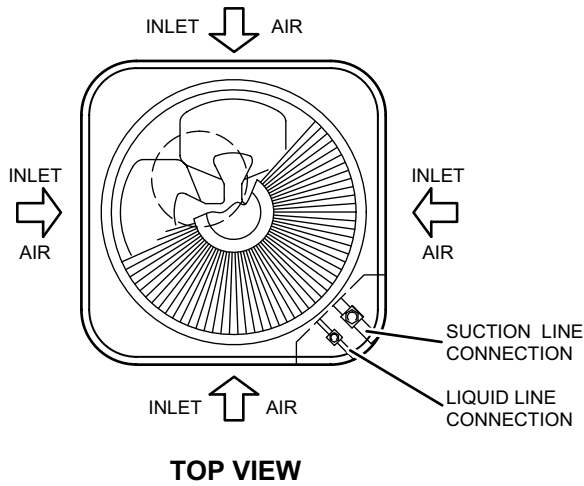

Size	A		B		C Height	
	inches	mm	inches	mm	inches	mm
024	28-1/4	718	28-1/4	718	29-1/4	743
036	28-1/4	718	28-1/4	718	29-1/4	743
048	28-1/4	718	28-1/4	718	29-1/4	743
060	28-1/4	718	28-1/4	718	43-1/4	1099

## SOUND DATA

Size	Octave Band Sound Power Levels dBA, re 10 <sup>-12</sup> Watts Center Frequency - HZ							<sup>1</sup> Sound Rating Number (dBA)	<sup>2</sup> Estimated Sound Pressure Level at Distance From Unit (dBA at distance in ft.)				
	125	250	500	1000	2000	4000	8000		3	5	10	15	50
024	56.5	63.0	67.2	71.4	67.7	63.2	59.0	75	68	63	57	54	43
036	54.6	61.5	66.8	69.2	63.3	58.3	54.3	73	66	61	55	52	41
048	56.7	63.6	68.6	70.4	65.5	61.6	54.9	74	67	62	56	53	42
060	57.6	63.1	69.2	70.9	67.0	64.4	59.2	75	68	63	57	54	43

NOTE - the octave sound power data does not include tonal correction.

<sup>1</sup> Tested according to AHRI Standard 270-2008 test conditions.

<sup>2</sup> Estimated sound pressure level at distance based on AHRI Standard 275-2010 method for equipment located on the ground, roof, or on side of building wall with no adjacent reflective surface within 9.8 feet. Sound pressure levels will increase based on changes to assumptions. For other applications, refer to AHRI Standard 275.

## FIELD WIRING

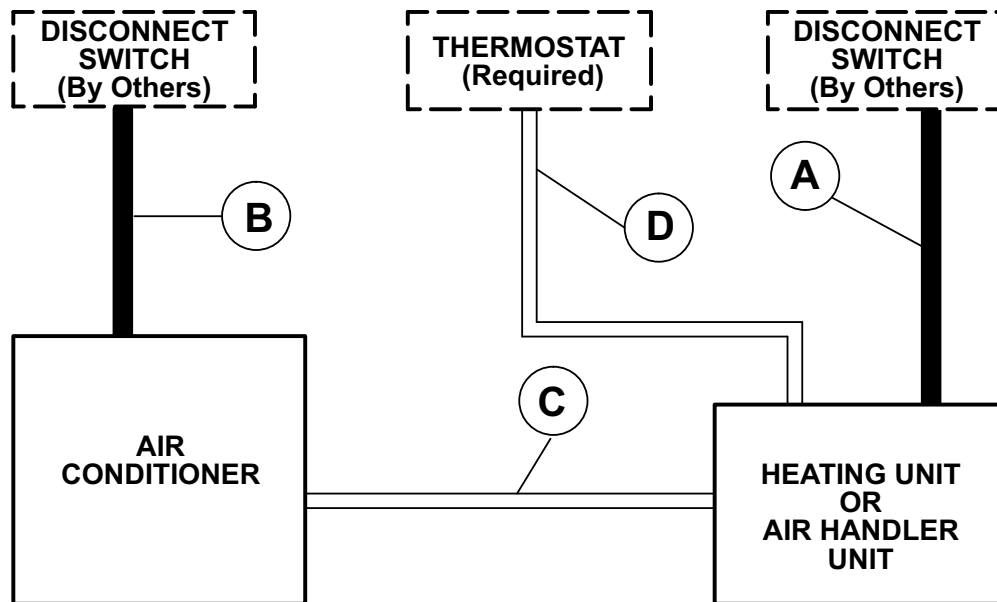

A - Two Wire Power (not furnished). See Indoor Unit Electrical Data

B - Two Wire Power (not furnished). See Electrical Data

C - Four Wire Low Voltage (not furnished). 18 ga. minimum

D - Five Wire Low Voltage (not furnished). 18 ga. minimum

All wiring must conform to NEC or CEC and local electrical codes.

# INSTALLATION CLEARANCES

## Clearance for Single-Unit Installation

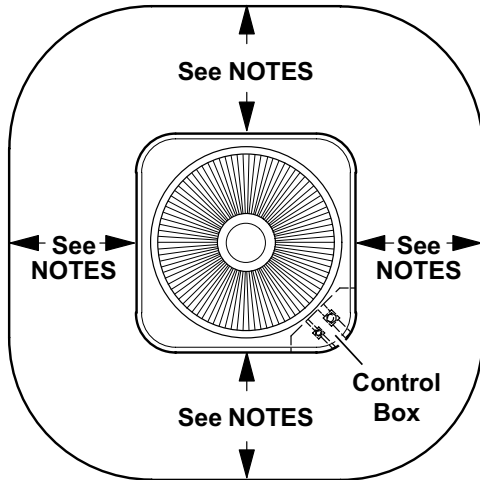

### Single-Unit Installation Notes:

- Service Clearance – 24 in. (610 mm) on one of the sides adjacent to the Control Box.
- One of other three sides must be 36 in. (914 mm).
- One of the two remaining sides may be 12 in. (305 mm).
- The remaining side may be 6 in. (152 mm).
- 48 in. (1219 mm) clearance required on top of unit

## Clearance for Multi-Unit Installation

### Single Row

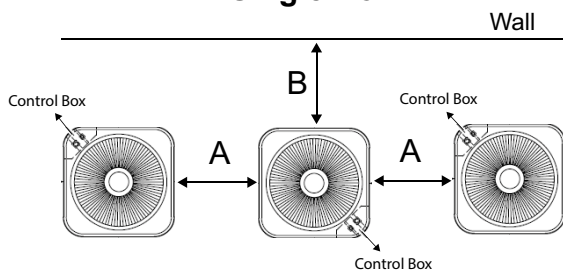

Required Minimum Clearances	A	B
	12 in. (305 mm) [18 in. (457 mm) recommended]	12 in. (305 mm)

### Multiple Row

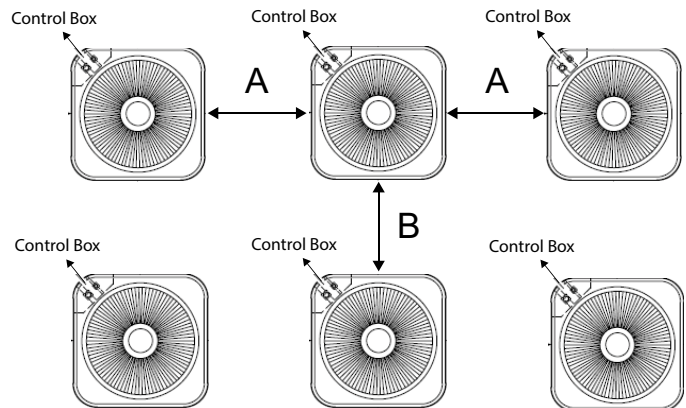

Required Minimum Clearances	A	B
	12 in. (305 mm) [18 in. (457 mm) recommended]	24 in. (610 mm)

### Multi-Unit Installation Notes:

- Recommended service clearance of 24 in. (610 mm) on one side.
- In all cases 48 in. (1219 mm) clearance required on top of the unit.

## TXV USAGE

All Allied coils and air handlers are shipped with a factory installed TXV. In most cases, no substitution is needed. If a different size TXV is required, it will be listed in the "TXV SUBSTITUTION" table by size. The correct TXV must be ordered separately and field installed.

Size	Order Number
024	<b>26Z70</b>
036	<b>26Z70</b>
048	<b>26Z71</b>
060	<b>26Z72</b>

## AHRI STANDARD 210-240-2023

Standard Ratings relating to cooling or heating capacities shall be net values, including the effects of circulating-fan heat, but not including supplementary electric heat. Power input used for calculating efficiency shall be the Total Power.

Standard Ratings of units which do not have indoor air-circulating fans furnished as part of the model, i.e., Coil-only System, shall be established by subtracting from the total cooling capacity 1,505 Btu/h per 1,000 SCFM, and by adding the same amount to the heating capacity for non-mobile-home, non-Space Constrained units. Total Power for both heating and cooling shall be increased by 441 W per 1,000 SCFM of indoor air circulated.

## TXV SUBSTITUTION - R-454B

A general guide for replacing the factory installed R-454B TXV if the indoor unit (coil/air handler) is larger or smaller than the outdoor unit.

Outdoor Unit		Indoor Unit		Indoor TXV Furnished	Indoor TXV Replacement
Size	Tons	Size	Tons		
024	2	42	3.5	<b>26Z71</b>	<b>26Z70</b>
024	2	48	4	<b>26Z71</b>	<b>26Z70</b>
024	2	49	4	<b>26Z71</b>	<b>26Z70</b>
024	2	50/60	4/5	<b>26Z71</b>	<b>26Z70</b>
024	2	51/61	4/5	<b>26Z71</b>	<b>26Z70</b>
024	2	60	5	<b>26Z72</b>	<b>26Z70</b>
036	3	42	3.5	<b>26Z71</b>	<b>26Z70</b>
036	3	48	4	<b>26Z71</b>	<b>26Z70</b>
036	3	49	4	<b>26Z71</b>	<b>26Z70</b>
036	3	50/60	4/5	<b>26Z71</b>	<b>26Z70</b>
036	3	51/61	4/5	<b>26Z71</b>	<b>26Z70</b>
036	3	60	5	<b>26Z72</b>	<b>26Z70</b>
048	4	30/36	2.5/3	<b>26Z70</b>	<b>26Z71</b>
048	4	36	3	<b>26Z70</b>	<b>26Z71</b>
048	4	60	5	<b>26Z72</b>	<b>26Z71</b>
060	5	50/60	4/5	<b>26Z71</b>	<b>26Z72</b>
060	5	51/61	4/5	<b>26Z71</b>	<b>26Z72</b>

### TXV Ranges:

**26Z70** - 1.5 to 3 ton systems - Use on 3 ton (036) and lower systems.

**26Z71** - 3.5-4 ton systems - Use on 4 ton (048) and down to 3.5 ton (042) systems.

**26Z72** - 5 ton systems - Use on 5 ton (060) systems only.



Visit us at [www.alliedair.com](http://www.alliedair.com)  
Contact us at 1-800-448-5872

NOTE - Due to our ongoing commitment to quality, Specifications, Ratings and Dimensions subject to change without notice and without incurring liability.  
Improper installation, adjustment, alteration, service or maintenance can cause property damage or personal injury.  
Installation and service must be performed by a qualified installer and servicing agency.

©2026 Allied Air Enterprises.