

# 7AHW/4AHW

## PRODUCT SPECIFICATIONS

## WALL MOUNT AIR HANDLER

FORM NO. 7AHW/4AHW-100 (05/2025)



### **CABINET & GENERAL FEATURES**

- Flexible copper tubing for easy motor access.
- Low 31" height on models 18 - 37.
- Cabinets Constructed of heavy-gauge, corrosion-resistant galvanized steel.
- Refrigerant connections located on top left.
- 5/8" foil-faced insulation for excellent sweat resistance and quiet operation.
- (4) Screw removal for easy access to all electrical connections
- Dual condensate drain connections on left side, right side, and bottom of cabinet.
- 1" duct flanges on all models simplify attachment to plenums.
- Air filter included with every air handler; no tools required for change out.
- Decorative wall panel (26"w x 38"h) or closet panel (24"w x 27"h) allow optimal airflow while reducing sound levels.
- Wall hanging bracket available as accessory for field installation.
- Approved for installation in manufactured housing and mobile homes.

### **COIL FEATURES**

- AC or HP applications:
  - A1 models suitable for use with R-22 & R-410A.
  - A2L models suitable for use with R-32 and R-454B and include factory installed Refrigerant Detection System (RDS).
- Proven copper tube and aluminum fin coil technology.
- Factory installed threaded expansion valve.
- Corrosion proof plastic drain pan.

### **ELECTRICAL FEATURES**

- High efficiency ECM motor or PSC motor available.
- Easy to service electric heat section.
- 5, 7.5, or 10 kW heat kits standard factory installed.
- Pull disconnect line voltage connection standard on all models.
- Patented condensate drain pan safety float switch available as accessory.
- Includes thermostat connections, time delay (1 sec. on, 45 sec. off), & motor uses control board; functions are built into the ECM motor).



**MODEL NUMBER GUIDE**

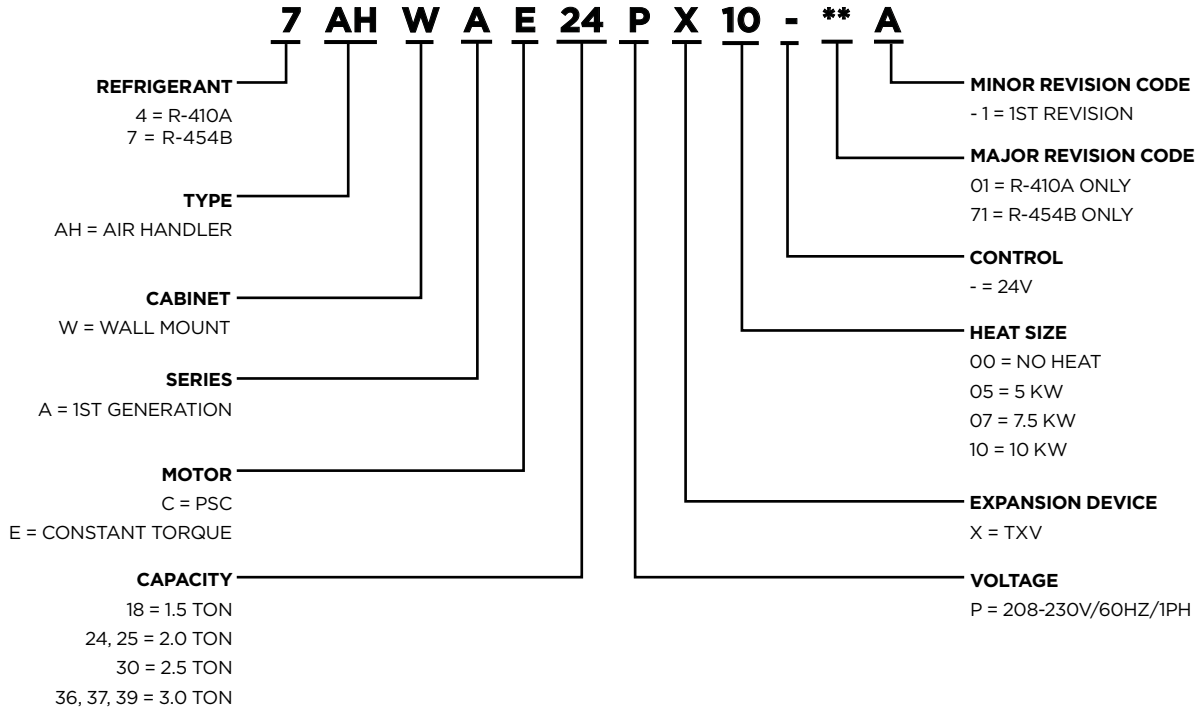

**PHYSICAL DATA**

	Unit Size							
	18	24	25	30	36	37	39	
Available Voltages	208/240 V , 60 Hz 1 Phase							
Maximum Elec. Heat available (KW)	5	7	7	7	10	10	10	
Transformer Size and Type	40VA, Class 2							
Blower Data: 3-Speed PSC Motor	Motor H.P.	1/4	1/4	--	1/3	1/3	--	--
	F.L.A. @240 V	1/7	1/7	--	2.0	2.0	--	--
Blower Data: 5-Speed High Eff, ECM Motor	Motor H.P.	--	--	1/3	--	--	1/2	1/2
	F.L.A. @240 V	--	--	1.7	--	--	2.9	2.9
Wheel (dia. " x width")	10X6	10X6	10X6	10X6	10X6	10X6	10X6	
Nominal CFM	600	800	800	1000	1200	1200	1200	
Air Filter Size (in)	20X20	20X20	20X20	20X20	20X25	20X25	20X30	
Refrigerant Conn. (IDS) Suction	3/4"	3/4"	3/4"	3/4"	3/4"	3/4"	3/4"	
Refrigerant Conn. (IDS) Liquid	3/8"	3/8"	3/8"	3/8"	3/8"	3/8"	3/8"	
Sound Level @0.3 Static w/o Wall Panel (dBA) <sup>(1)</sup>	60	64	64	69	72	69	69	
Max Unit Weight (lbs)	78	78	81	81	81	84	87	
Max Shipping Weight (lbs)	85	85	90	90	100	105	108	

Note: 18" Clearance required in front of unit for filter and coil maintenance. Can be less if front panel is directly behind a louvered closet door; check local codes and regulations.

**ELECTRICAL DATA**  
**3-SPEED PSC MOTOR**

Unit Size	Elec. Heating Cap.		Blower Amps		Min. Circuit Ampacity		Max. Circuit Breaker Size	
	kW	Btuh	208V	240V	208V	240V	208V	240V
	240V <sup>(1)</sup>	240V <sup>(1)</sup>						
7AHWAC18PX00-71A 4AHWAC18PX05-01A 7AHWAC18PX05-71A	0	0	1.8	1.7	2.3	2.1	15	15
	5.0	17,061	1.8	1.7	24.8	28.2	25	30
7AHWAC24PX00-71A 4AHWAC24PX05-01A 7AHWAC24PX05-71A 4AHWAC24PX07-01A 7AHWAC24PX07-71A	0	0	1.8	1.7	2.3	2.1	15	15
	5.0	17,061	1.8	1.7	24.8	28.2	25	30
	7.5	25,591	1.8	1.7	36.1	41.2	40	45
7AHWAC30PX00-71A 4AHWAC30PX05-01A 7AHWAC30PX05-71A 4AHWAC30PX07-01A 7AHWAC30PX07-71A	0	0	2.1	2.0	2.6	2.5	15	15
	5.0	17,061	2.1	2.0	25.2	28.5	30	30
	7.5	25,591	2.1	2.0	36.5	41.6	40	45
7AHWAC36PX00-71A 4AHWAC36PX07-01A 7AHWAC36PX07-71A 4AHWAC36PX10-01A 7AHWAC36PX10-71A	0	0	2.1	2.0	2.6	2.5	15	15
	7.5	25,591	2.1	2.0	36.5	41.6	40	45
	10.0	34,121	2.1	2.0	47.8	54.6	50	60

(1) For 208 Volts use, 751 correction factor for KW&MBTUH

**5-SPEED HIGH EFFICIENCY ECM MOTOR**

Unit Size	Heating Cap.		Blower Amps		Min. Circuit Ampacity		Max. Circuit Breaker Size	
	kW	Btuh	208V	240V	208V	240V	208V	240V
	240V <sup>(1)</sup>	240V <sup>(1)</sup>						
7AHWAE25PX00-71A 4AHWAE25PX05-01A 7AHWAE25PX05-71A 4AHWAE25PX07-01A 7AHWAE25PX07-71A	0	0	1.8	1.7	2.3	2.1	15	15
	5.0	17,061	1.8	1.7	24.8	28.2	25	30
	7.5	25,591	1.8	1.7	36.1	41.2	40	45
7AHWAE37PX00-71A 7AHWAE37PX05-71A 4AHWAE37PX07-01A 7AHWAE37PX07-71A 4AHWAE37PX10-01A 7AHWAE37PX10-71A	0	0	3.1	2.9	3.9	3.6	15	15
	5.0	17,061	3.1	2.9	26.4	29.7	30	30
	7.5	25,591	3.1	2.9	37.7	42.7	40	45
	10.0	34,121	3.1	2.9	49.0	55.7	50	60
7AHWAE39PX00-71A 7AHWAE39PX05-71A 7AHWAE39PX07-71A 7AHWAE39PX10-71A	0	0	3.1	2.9	3.9	3.6	15	15
	5.0	17,061	3.1	2.9	26.4	29.7	30	30
	7.5	25,591	3.1	2.9	37.7	42.7	40	45
	10.0	34,121	3.1	2.9	49.0	55.7	50	60

(1) For 208 Volts use, 751 correction factor for KW&MBTUH

**BLOWER PERFORMANCE DATA**

**3-SPEED PSC MOTOR**

Unit Size	Cooling Speed Setting	Airflow (CFM) vs. External Static Pressure (inches W.C.)***				
		0.1	0.2	0.3	0.4	0.5
7AHWAC18PX00-71A 4AHWAC18PX05-01A 7AHWAC18PX05-71A	* ^ Low-Red	606	591	576	559	529
	Med - Blue	802	784	751	722	693
	High - Black	1046	1013	987	943	885
7AHWAC24PX00-71A 4AHWAC24PX05-01A 7AHWAC24PX05-71A 4AHWAC24PX07-01A 7AHWAC24PX07-71A	Low-Red	606	591	576	559	529
	* ^ Med - Blue	802	784	751	722	693
	High - Black	1046	1013	987	943	885
7AHWAC30PX00-71A 4AHWAC30PX05-01A 7AHWAC30PX05-71A 4AHWAC30PX07-01A 7AHWAC30PX07-71A	Low-Red	816	809	802	775	752
	* ^ Med - Blue	1000	985	970	935	889
	High - Black	1218	1175	1122	1070	1008
7AHWAC36PX00-71A 4AHWAC36PX07-01A 7AHWAC36PX07-71A 4AHWAC36PX10-01A 7AHWAC36PX10-71A	Low-Red	816	809	802	775	752
	* ^ Med - Blue	1000	985	970	935	889
	High - Black	1218	1175	1122	1070	1008

\* Factory setting for cooling.  
 ^ Factory setting for heating.  
 \*\*\* All airflow data is with a dry coil, filter, & electric heat.  
 Do not adjust heating airflow below factory setpoint.

**5-SPEED HIGH EFFICIENCY ECM MOTOR**

Unit Size	Cooling Speed Setting	Airflow (CFM) vs. External Static Pressure (inches W.C.)***				
		0.1	0.2	0.3	0.4	0.5
7AHWAE25PX00-71A 4AHWAE25PX05-01A 7AHWAE25PX05-71A 4AHWAE25PX07-01A 7AHWAE25PX07-71A	Tap 1	569	453	347	264	264
	Tap 2	659	600	569	518	475
	* Tap 3	847	800	787	744	722
	^ Tap 4	928	901	883	846	802
	Tap 5	970	944	927	891	864
7AHWAE37PX00-71A 7AHWAE37PX05-71A 4AHWAE37PX07-01A 7AHWAE37PX07-71A 4AHWAE37PX10-01A 7AHWAE37PX10-71A	Tap 1	848	800	769	726	692
	Tap 2	1051	1028	1000	956	930
	* Tap 3	1247	1215	1188	1161	1126
	^ Tap 4	1310	1279	1254	1228	1200
	Tap 5	1364	1334	1304	1279	1250
7AHWAE39PX00-71A 7AHWAE39PX05-71A 7AHWAE39PX07-71A 7AHWAE39PX10-71A	Tap 1	800	783	747	725	689
	Tap 2	1034	1003	987	959	937
	* Tap 3	1281	1253	1228	1207	1186
	^ Tap 4	1343	1314	1290	1261	1226
	Tap 5	1367	1342	1312	1277	1239

\* Factory setting for cooling.  
 ^ Factory setting for heating.  
 \*\*\* All airflow data is with a dry coil, filter, & electric heat.  
 Do not adjust heating airflow below factory setpoint.

**ACCESSORIES**

Accessory Description	Catalog Number
Wall Hanging Bracket (qty of 1)	1.841206
Wall Hanging Bracket (qty of 10)	1.841210
Float Switch	1.841208
Decorative Wall Panel (finished, no louvers)	1.841207
Decorative Closet Panel (unfinished, no louvers)	1.841209
Sound Isolation Panel	1.841242

Accessory Description	Catalog Number
5.0 kW Heater Kit	29Y72
7.5 kW Heater Kit	29Y74
10 kW Heater Kit	29Y76

**UNIT DIMENSIONS**

Air Handler Size	A (In)	B (In)	C (In)
18-37	22	18.75	31
39	22	18.75	35.5

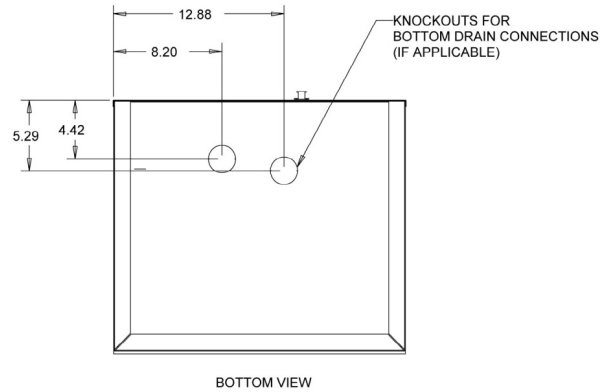
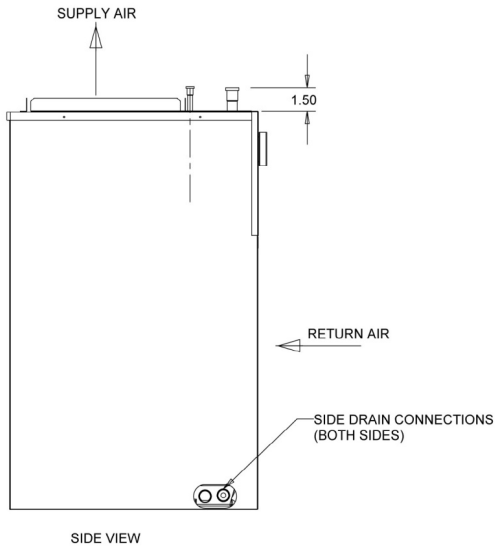
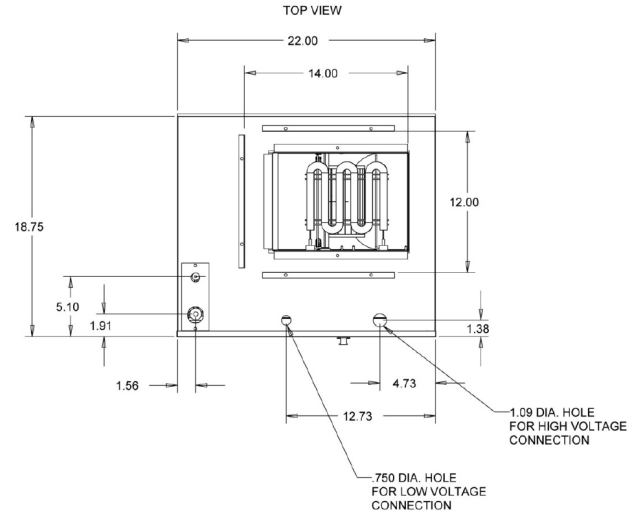
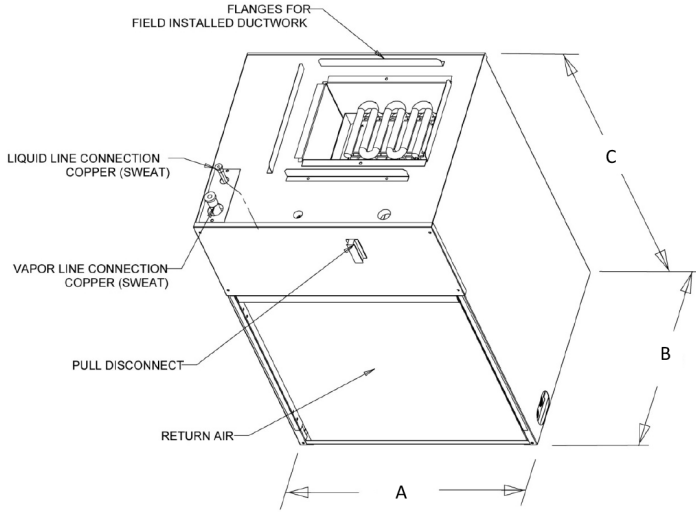

1-800-448-5872

All specifications and illustrations subject to change without notice and without incurring obligations.