

RPGEV-715

PRODUCT SPECIFICATIONS

TWO STAGE COMPRESSOR
VARIABLE SPEED BLOWER

FORM NO. RPGEV-100 (12/2025)



MODEL NUMBER

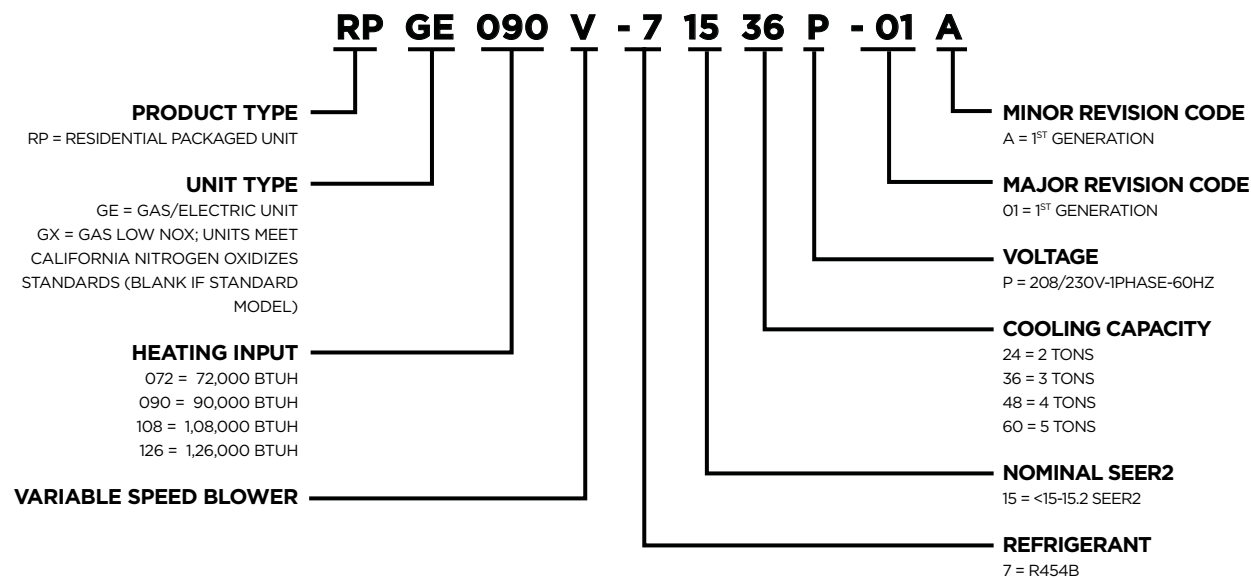

FEATURES AND BENEFITS

WARRANTY

10 year limited parts and compressor warranty. See limited warranty document for details.

APPLICATIONS

Designed for outdoor installations at ground level or rooftop for residential and light commercial applications.

APPROVALS

AHRI Certified to AHRI Standard 210/240-2008.

Units are design certified by ETL Intertek.

Heating ratings are according to Department of Energy (DOE) test procedures and Federal Trade Commission (FTC) labeling regulations and are Certified by AHRI.

"GX" models are approved by the California Energy Commission and meet California Nitrogen Oxides Standard (NOx) limits of 40 ng/J.

Cooling system rated according to DOE test procedures.

Units are ETL certified for the U.S. and Canada.

Packaged unit and components within bonded for grounding to meet safety standards required by UL.

Each unit test operated at the factory before shipment ensuring dependable operation at start-up.

Seismic Certification (with Seismic Strapping Kit applied): Latest Edition of International Building Code, California Building Code, and ASCE 7-16.

California Only

This product is not certified to be sold or installed in the South Coast Air Quality Management District (SCAQMD). It does not meet the SCAQMD Rule 1111 NOx emission limit of 14 Ng/J.

This product is not certified to be sold or installed in the San Joaquin Valley Air Pollution Control District (SJVAPCD). It does not meet the SJVAPCD Rule 4905 NOx emission limit of 14 Ng/J.

For packaged units that meet SCAQMD/SJVAPCD requirements, refer to the PRPGN14 technical specification.

HEATING SYSTEM

Heat Exchanger

Aluminized tubular steel for superior resistance to corrosion and oxidation.

Round surfaces create minimum air resistance and allow air to surround all surfaces for excellent heat transfer.

Heat exchanger has been laboratory life cycle tested.

Tri-Diamond Technology

This unique, advanced design allows more air to contact the tubular heat exchanger, providing greater heat transfer and efficiency.

Optimal heat exchange allows for a more compact and energy-efficient design.

The Tri-Diamond design eliminates issues caused by condensation developed during the cooling season leading to reliable startup every season.

Without a fresh air intake, Tri-Diamond also reduces oxide formation and corrosion caused by recirculation.

Inshot Burners

Aluminized steel inshot burners provide efficient trouble free operation.

Burner venturi mixes air and gas in correct proportion for proper combustion.

Burner assembly is removable from the unit as a single component for ease of service and each burner may be removed individually.

Two-Stage Gas Control Valve

24 volt redundant combination two-stage gas control valve combines manual shut off valve (On-Off), automatic electric valve (dual) and gas pressure regulation into a compact combination control.

Two-Stage Combustion Air Inducer

Heavy duty combustion air inducer prepurges heat exchanger and safely vents flue products.

Blower is controlled by the ignition control board.

Pressure switch proves blower operation before allowing gas valve to open.

Combustion air inducer operates during heating cycle.

Inducer also operates for the first 10 seconds of every cooling cycle to prevent insects from nesting in the flue outlet during cooling season.

Limit Controls

Automatic reset, primary limit is accurately located.

Primary limit factory installed behind heat exchanger access panel.

Flame Rollout Switch

Manual reset switch is factory installed on burner box.

Switch provides protection from abnormal operating conditions.

Ignition Control Board

Ignition control board with LED diagnostics.

Optional Accessories

LPG/Propane Conversion Kit

Required for field changeover from natural gas to LPG/Propane.

Bottom Gas Entry Kit

Allows gas piping connection through the unit base pan.

REFRIGERATION SYSTEM

R-454B Refrigerant

Non-chlorine, ozone friendly, R-454B.

Unit pre-charged with refrigerant.

See Specification table.

Evaporator and Condenser Coils

Copper tube with aluminum fin coils.

Insulated Antimicrobial Evaporator Coil Drain Pan

Antimicrobial additive resists growth of mold and mildew on drain pan which improves indoor air quality and reduces drain line blockage.

Insulated to reduce condensation.

Includes drain pan overflow switch. Monitors condensate level in drain pan, shuts down unit if drain becomes clogged.

Condenser Fan

Weather protected heavy duty condenser fan motor with coated steel swept wing fan blades for long life.

Internally mounted.

Totally enclosed motor.

Fan guard constructed of corrosion-resistant coated steel.

High Pressure Switch

Shuts off unit if abnormal operating conditions cause the discharge pressure to rise above setting.

Protects compressor from excessive condensing pressure. Automatic reset.

Loss of Charge Switch

Shuts off unit if suction pressure falls below setting.

Provides loss of charge and freeze-up protection.

SCROLL COMPRESSOR

Two-Stage Compressor

Compressor features high efficiency with uniform suction flow, constant discharge flow, high volumetric efficiency and quiet operation.

Compressor consists of two involute spiral scrolls matched together to generate a series of crescent shaped gas pockets between them.

During compression, one scroll remains stationary while the other scroll orbits around it.

Gas is drawn into the outer pocket, the pocket is sealed as the scroll rotates.

As the spiral movement continues, gas pockets are pushed to the center of the scrolls. Volume between the pockets is simultaneously reduced.

When the pocket reaches the center, gas is now at high pressure and is forced out of a port located in the center of the fixed scrolls. During compression, several pockets are compressed simultaneously resulting in a smooth continuous compression cycle.

Continuous flank contact, maintained by centrifugal force, minimizes gas leakage and maximizes efficiency.

Scroll compressor is tolerant to the effects of slugging and contaminants. If this occurs, scrolls separate, allowing liquid or contaminants to be worked toward the center and discharged.

During the compression process, there are several pockets in the scroll that are compressing gas. Modulation is achieved by venting a portion of the gas in the first suction pocket back to the low side of the compressor thereby reducing the effective displacement of the compressor.

A 24-volt DC solenoid valve inside the compressor controls staging. When the 3-way solenoid is energized it moves the lift ring assembly to block the ports and the compressor operates at full-load or 100% capacity. When the solenoid is de-energized the lift ring assembly moves to unblock the compressor ports and the compressor operates at part-load or approximately 67% of its full-load capacity.

The “loading” and “unloading” of the two stage scroll is done “on the fly” without shutting off the single-speed compressor motor between stages.

Low gas pulses during compression reduce operational sound levels.

Compressor motor is internally protected from excessive current and temperature.

Compressor is installed in the unit on specially formulated, resilient rubber mounts for better sound dampening and vibration free operation.

Heavy Duty Compressor Blanket

Durable PVC outer cover with sound insulating inner polyester fiber.

Optional Accessories

Compressor Crankcase Heater

Protects against refrigerant migration that can occur during low ambient operation.

Compressor Hard Start Kit

Single-phase units are equipped with a PSC compressor motor. This type of motor normally doesn't need a potential relay and start capacitor.

In conditions such as low voltage, this kit may be required to increase the compressor starting torque.

Compressor Timed-Off Control

Prevents compressor short-cycling and allows time for suction and discharge pressure to equalize. Permits compressor start-up in an unloaded condition. Automatic reset with 5 minute delay between compressor shut-off and start-up.

Freezestat

Senses suction line temperature.

Cycles compressor off when suction line temperature falls below its setpoint.

Low Ambient Kit

Cycles the outdoor fan while allowing compressor operation in the cooling cycle.

This intermittent fan operation allows the system to operate without icing the evaporator coil and losing capacity.

Designed for use in ambient temperatures no lower than 0°F.

NOTE - Crankcase heater and freezestat are recommended on compressor equipped with a low ambient kit.

SUPPLY AIR BLOWER

Variable Speed Direct Drive Blower

Each blower wheel statically and dynamically balanced.

Multi-speed operation is achieved by the use of an ECM (Electronically Commutated Motor) variable speed motor.

See Blower Performance tables.

Blower assembly easily removed for servicing.

ECM Variable Speed Blower Motor

Variable speed motor maintains specified air volume from 0 though 0.80 in. w.g. static range.

Motor is controlled by the blower control.

Change in blower speed is easily accomplished by simple jumper pin change on blower control.

Motor is resiliently mounted.

CONTROLS

Electronic Blower Control

Two stages - HEAT and COOL (with four different air volume selections for each) are made by simple jumper pins.

ADJUST jumper pin allows approximately 10% higher, normal or 10% lower motor speed selection within (COOL) speeds selected for fine tuning air volume. See Blower Data tables.

NOTE - HEAT speeds are not affected by jumper change.

Cooling Airflow Ramp Up - At the beginning of a call for cooling, the blower will run at 82% of full airflow for 7.5 minutes. This improves the system's moisture removal and saves blower power during cooling start.

Reduced Airflow Operation - For situations where humidity control is an issue, the variable speed motor can be connected to operate at a 25% reduction in the normal airflow rate. The variable speed motor interface provides for connection of a thermostat with humidity control or a humidistat on the HUM terminal. When connected, the dehumidifier resistor on the interface must be cut. The control should be wired to open during high humidity, which will reduce blower airflow.

24 Volt Transformer

40VA transformer furnished and factory installed in control area.

Optional Accessories

Comfort Sync® Equipment Interface Module

Allows Comfort Sync® Thermostats to be used with residential packaged units.

Contains all necessary relays and controls to operate the system and communicate with the Comfort Sync® Thermostat.

NOTE - The Comfort Sync® Equipment Interface Module is required for proper operation of Comfort Sync® Thermostats with residential packaged units.

Comfort Sync® Thermostat

The Comfort Sync® Thermostat recognizes and connects conventional heating/cooling products to automatically configure and control the system (based on user-specified settings) for the highest level of comfort, performance and efficiency.

Wi-Fi remote temperature monitoring and adjustment through a home wireless network for desktop PCs, laptops and apps for smartphones or tablets. Also displays service alerts and reminders.

A simple easy-to-use touchscreen allows complete system configuration. Scheduled maintenance alerts, system warnings and troubleshooting are also displayed on thermostat screen.

One-Touch Away Mode - A quick and easy way to set the cooling and heating setpoints while away.

Weather-On-Demand - Live up-to-date weather data and five-day forecasts.

Easy to read 7-inch color screen (measured diagonally).

See the Comfort Sync® Thermostat Product Specifications bulletin in the CONTROLS section for more information.

CABINET

Conditioned areas insulated with foil faced insulation to minimize heat loss and reduce operating sound levels.

Pre-painted, galvanized steel for maximum durability.

Full perimeter heavy-gauge galvanized steel base rails.

Base rails have rigging holes.

Two sides of the base rails have forklift slots.

Raised edges around duct and power entry openings in the bottom of the unit for water protection.

Easy service access.

Steel louvered panels provides complete coil protection.

Airflow Choice

Units are shipped with horizontal and downflow duct covers provided unit for installation flexibility.

Electrical Inlets and Service Valves

Field wiring inlets are located in one central area of the cabinet. See dimension drawing.

Gauge ports located inside compressor service compartment of the cabinet.

Optional Accessories

Bottom Entry Power Kit

Allows high and low voltage wiring connections through the unit base pan.

Base Rail Openings Closure Kit

Kit consists of panels and hardware to cover rigging holes and forklift slots in unit base rails.

Square to Round Duct Adapter Kits

Downflow or horizontal kits available.

Converts square supply and return air openings on unit cabinet to round 14 in. diameter.

ROOF CURBS

Field Installed

Clip Curb (Full Perimeter)

Interlocking tabs fasten corners together.

No tools required.

Fully gasketed around curb perimeter and supply and return openings.

Available in 8, 14, 18 and 24 inch heights.

Shipped knocked down.

Wind rating - 240mph (Lateral), 214mph (Uplift).

Adjustable Pitch Roof Curb (Full Perimeter) - Standard Curb

Fully adjustable pitch curb provides a level platform for packaged units.

Allows flexible installations on roofs with sloped or uneven angles.

Adjustable from 2/12 to 6/12 pitch.

Constructed of heavy-gauge galvanized steel with fully welded seams and corners.

Rounded corners on flange prevent damage to roof shingles.

Built-in drip edge.

IAPMO/UMC listed.

All Clip and Adjustable Pitch Curbs

IBC 2018 compliant.

CBC 2019 compliant.

Seismic rating - SDS 2.0g, z/h=1, Ip=1.5.

Wind rating - 240 mph (Lateral), 214 mph (Uplift).

Maximum load rating - 800 lbs.

Adaptor Curbs (not shown)

Curbs are regionally sourced.

Dimensions vary based upon the source.

NOTE - Contact your local sales representative for a detailed cut sheet with applicable dimensions.

Strapping Kit - Hurricane

Galvanized steel .07 in. thick minimum.

Attaches unit base rails to host structure.

Strapping Kit - Seismic

Heavy-gauge galvanized steel.

Kit contains 4 brackets and mounting hardware.

INDOOR AIR QUALITY

Internal Filter Rack Kits

Available for 1 in. thick filters. Kit contains filter rails for mounting filters internal to unit. Filters are not furnished and must be field provided.

NOTE - The Internal Filter Rack Kit cannot be used with the PCO Accessory.

NOTE - Maximum acceptable filter efficiency is MERV 11.

SPECIFICATIONS

GENERAL DATA	MODEL NO.	RPGE072V-71524P	RPGE090V-71536P	RPGE108V-71548P	RPGE126V-71560P
	NOMINAL TONNAGE	2	3	4	5
GAS HEAT AVAILABLE - SEE PAGE 6		-72	-90	-108	-126
COOLING PERFORMANCE	Total cooling capacity - Btuh (SEER)	23,800	35,400	47,500	57,000
	Total cooling capacity - Btuh (SEER2)	23,800	34,000	46,000	57,000
	Total Unit Watts	1906	3030	3980	5014
	¹ SEER / EER (Btuh/Watt)	16.0/12.5	16.0/12.0	16.0/12.0	16.0/12.0
	¹ SEER2 / EER2 (Btuh/Watt)	16.0/12.0	15.2/11.5	15.2/11.5	15.2/11.5
	² Sound Rating Number (dB)	73	74	73	74
REFRIGERANT	Type	R-454B	R-454B	R-454B	R-454B
	Charge	80 OZ.	80 OZ	92 OZ	123 OZ
CONDENSATE DRAIN SIZE (FPT) - IN.		3/4	3/4	3/4	3/4
OUTDOOR COIL	Net Face Area - sq. ft.	14.6	16.4	19.5	19.1
	Tube Dia. - in. and No. of Rows	5/16-1	5/16-1	5/16-1	5/16-2
	Fins per inch	26	26	26	22
OUTDOOR COIL FAN	Motor horsepower	1/6	1/6	1/4	1/4
	Dia. - in. and No. of blades	22-3	22-3	24-3	24-3
INDOOR COIL	Net Face Area - sq. ft.	4.4	4.4	6.8	6.8
	Tube Dia. - in. and No. of rows	3/8-3	3/8-3	3/8-3	3/8-3
	Fins per in.	15	15	15	15
INDOOR BLOWER	Blower wheel size dia. x width - in.	10 x 6	10 x 8	10 x 10	12 x 9
	Motor horsepower	1/2	1/2	3/4	1
NET WEIGHT OF BASIC UNIT - LBS.		411	420	522	558
SHIPPING WEIGHT OF BASIC UNIT (1 PKG.) - LBS.		421	430	532	568
ELECTRICAL CHARACTERISTICS (60 HZ)		208/230V-1ph-60Hz			
ELECTRICAL DATA					
LINE VOLTAGE DATA - 60HZ 1 PHASE		208/230V	208/230V	208/230V	208/230V
³ MAXIMUM OVERCURRENT PROTECTION (AMPS)		25	35	45	60
⁴ MINIMUM CIRCUIT AMPACITY		15.1	21.5	28.2	37.5
COMPRESSOR	Rated load amps	10.2	14.5	18.3	25.2
	Locked rotor amps	58.3	83.0	126.5	151.0
OUTDOOR COIL FAN MOTOR	Full load amps	1.0	1.0	1.7	1.7
	Locked rotor amps	1.9	1.9	3.2	3.2
INDOOR BLOWER MOTOR	Full load amps	1.3	2.4	3.6	4.4
	Locked rotor amps	4.3	4.3	6.8	9.1

NOTE-Extremes of operating range are plus and minus 10% of line voltage.

¹ AHRI Certified to AHRI Standard 210/240; 95°F outdoor air temperature, 80°F db/67°F wb entering evaporator air.

² Sound Rating Number rated in accordance with test conditions included in AHRI Standard 270.

³ HACR type circuit breaker or fuse.

⁴ Refer to National or Canadian Electrical Code manual to determine wire, fuse and disconnect size requirements.

ACCESSORIES

DESCRIPTION		WHERE USED	KIT NUMBER
Compressor Crankcase Heater		24, 36	27U17
		48, 60	27P79
Compressor Hard Start Kit		All	10J42
Compressor Timed-Off Control		All	47J28
Low Ambient Kit		All	21D20
LPG/Propane Conversion Kit		All	15C55
Internal Filter Rack Kit		24, 30, 36	11U73
		42, 48, 60	11U74
8" Height Full Perimeter Curb		24, 30, 36	21J13
		42, 48, 60	21J17
14" Height Full Perimeter Curb		24, 30, 36	21J14
		42, 48, 60	21J19
18" Height Full Perimeter Curb		24, 30, 36	21J15
		42, 48, 60	21J20
24" Height Full Perimeter Curb		24, 30, 36	21J16
		42, 48, 60	21J25
Adjustable Pitch Roof Curb (Knock-Down Style)		24, 30, 36	21J26
		42, 48, 60	21U04
Adjustable Pitch Roof Curb (Welded Style)		24, 30, 36	22V54
		42, 48, 60	22V55
Strapping Kit - Hurricane		Slab	21J74
		Rail	22G53
Strapping Kit - Seismic		All	21J75
Duct Adapter Kit - Horizontal	14 in. dia.	24, 30, 36	21J92
	14 in. dia.	42, 48, 60	21D24
	16 in. dia.	42, 48, 60	22U78
	18 in. dia.	42, 48, 60	22U79
Duct Adapter Kit - Downflow	14 in. dia.	24, 30, 36	20X82
	14 in. dia.	42, 48, 60	21D26
Bottom Power Entry Kit		All	21J78
Base Rail Openings - Closure Kit		All	21J84
Comfort Sync® Thermostat		All	1.841226
Equipment Interface Module (EIM) - Required with Comfort Sync thermostat		All	R104785-01
Outdoor Air Temperature Sensor		All	X2658
Discharge Air Temperature Sensor		All	88K38

SPECIFICATIONS - GAS HEAT

GENERAL DATA		MODEL NO.	RPGEV-71524	RPGEV-71536	RPGEV-71548	RPGEV-71560
HEATING INPUT			-072	-090	-108	-126
HEATING CAPACITY BTUH	First Stage - Input		54,000	67,500	81,000	94,500
	Output		43,500	54,500	65,500	76,500
	Second Stage - Input		72,000	90,000	108,000	126,000
	Output		58,000	73,000	88,000	102,000
¹ AFUE			81%	81%	81%	81%
TEMPERATURE RISE - °F	First Stage		35 - 45	35 - 45	45 - 55	45 - 55
	Second Stage		45 - 55	45 - 55	50 - 60	50 - 60
GAS SUPPLY CONNECTION (FPT) - IN.			1/2	1/2	1/2	1/2
MIN. RECOMMENDED GAS SUPPLY PRESSURE		5 in. w.g. Natural Gas, 11 in. w.g. LPG/Propane				
OPTIONAL ACCESSORIES - ORDER SEPARATELY						
LPG/PROPANE CONVERSION KIT			15C55	15C55	15C55	15C55

¹ Annual Fuel Utilization Efficiency based on U.S. DOE test procedures and FTC labeling regulations.

HIGH ALTITUDE DERATE

Units may be installed at altitudes up to 4500 feet above sea level without any modification. At altitudes above 4500 feet, units must be derated 4% for every 1000 feet above sea level. Example - At an altitude of 6000 feet the unit would require a derate of 24%.

NOTE - This is the only permissible derate for these units.

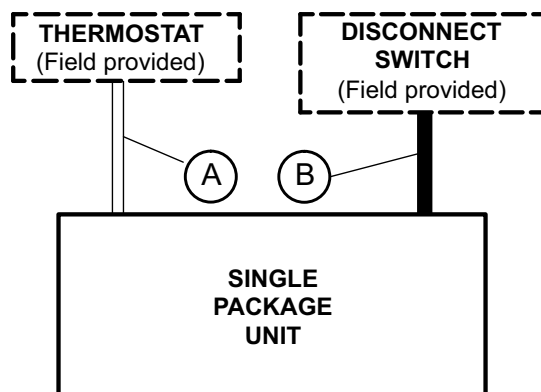
FIELD WIRING

A - Seven Wire Low Voltage (Electronic)

B - Two Wire Power (See Electrical Data Table)

- Field Wiring Not Furnished -

COOLING RATINGS

2 TON - RPGEV-71524 (1ST STAGE)																					
ENTERING WET BULB TEMP.	TOTAL AIR VOLUME	OUTDOOR AIR TEMPERATURE ENTERING OUTDOOR COIL																			
		75°F					85°F					95°F					105°F				
		TOTAL COOL CAP.	COMP. MOTOR INPUT	SENSIBLE TO TOTAL RATIO (S/T)			TOTAL COOL CAP.	COMP. MOTOR INPUT	SENSIBLE TO TOTAL RATIO (S/T)			TOTAL COOL CAP.	COMP. MOTOR INPUT	SENSIBLE TO TOTAL RATIO (S/T)			TOTAL COOL CAP.	COMP. MOTOR INPUT	SENSIBLE TO TOTAL RATIO (S/T)		
				DRY BULB					DRY BULB					DRY BULB					DRY BULB		
CFM	KBTUH	KW	75°F	80°F	85°F	KBTUH	KW	75°F	80°F	85°F	KBTUH	KW	75°F	80°F	85°F	KBTUH	KW	75°F	80°F	85°F	
63°F	440	18.6	5.5	.71	.84	.96	17.8	5.2	.72	.85	.98	16.9	5.0	.74	.87	1.00	15.9	4.7	.76	.90	1.00
	560	19.8	5.8	.77	.91	1.00	18.9	5.5	.78	.93	1.00	17.9	5.2	.80	.96	1.00	16.8	4.9	.82	.99	1.00
	720	21.0	6.2	.83	1.00	1.00	20.0	5.9	.85	1.00	1.00	19.1	5.6	.88	1.00	1.00	18.1	5.3	.91	1.00	1.00
67°F	440	19.8	5.8	.57	.69	.80	18.9	5.5	.57	.70	.82	18.0	5.3	.59	.71	.84	16.9	5.0	.60	.74	.87
	560	21.0	6.2	.60	.74	.87	20.0	5.9	.61	.76	.90	19.0	5.6	.62	.77	.92	17.7	5.2	.63	.79	.96
	720	22.0	6.4	.64	.81	.97	21.0	6.2	.65	.83	.99	19.9	5.8	.66	.85	1.00	18.6	5.5	.69	.89	1.00
71°F	440	20.8	6.1	.43	.55	.66	20.0	5.9	.43	.56	.67	19.0	5.6	.44	.57	.69	17.8	5.2	.45	.58	.71
	560	22.0	6.4	.45	.58	.72	21.2	6.2	.45	.60	.73	20.0	5.9	.46	.61	.75	18.8	5.5	.46	.62	.77
	720	23.2	6.8	.47	.62	.78	22.2	6.5	.47	.64	.80	21.0	6.2	.49	.66	.83	19.6	5.7	.48	.67	.86

NOTE: Values based on 0.50" w.c. external static pressure

2 TON - RPGEV-71524 (2ND STAGE)																					
ENTERING WET BULB TEMP.	TOTAL AIR VOLUME	OUTDOOR AIR TEMPERATURE ENTERING OUTDOOR COIL																			
		85°F					95°F					105°F					115°F				
		TOTAL COOL CAP.	COMP. MOTOR INPUT	SENSIBLE TO TOTAL RATIO (S/T)			TOTAL COOL CAP.	COMP. MOTOR INPUT	SENSIBLE TO TOTAL RATIO (S/T)			TOTAL COOL CAP.	COMP. MOTOR INPUT	SENSIBLE TO TOTAL RATIO (S/T)			TOTAL COOL CAP.	COMP. MOTOR INPUT	SENSIBLE TO TOTAL RATIO (S/T)		
				DRY BULB					DRY BULB					DRY BULB					DRY BULB		
CFM	KBTUH	KW	75°F	80°F	85°F	KBTUH	KW	75°F	80°F	85°F	KBTUH	KW	75°F	80°F	85°F	KBTUH	KW	75°F	80°F	85°F	
63°F	600	23.0	6.7	.72	.84	.97	21.8	6.4	.73	.86	.99	20.8	6.1	.75	.88	1.00	19.6	5.7	.77	.91	1.00
	800	24.4	7.2	.78	.94	1.00	23.4	6.9	.79	.96	1.00	22.0	6.4	.82	.99	1.00	20.8	6.1	.85	1.00	1.00
	1000	25.6	7.5	.85	1.00	1.00	24.6	7.2	.87	1.00	1.00	23.4	6.9	.89	1.00	1.00	22.0	6.4	.93	1.00	1.00
67°F	600	24.2	7.1	.57	.69	.81	23.2	6.8	.58	.70	.83	22.0	6.4	.59	.72	.85	20.6	6.0	.60	.74	.88
	800	25.8	7.6	.61	.76	.90	24.6	7.2	.62	.78	.93	23.2	6.8	.63	.80	.95	21.8	6.4	.65	.82	.98
	1000	26.8	7.9	.64	.81	.99	25.6	7.5	.67	.85	1.00	24.2	7.1	.68	.87	1.00	22.6	6.6	.70	.91	1.00
71°F	600	25.4	7.4	.44	.56	.67	24.4	7.2	.44	.56	.68	23.0	6.7	.45	.57	.70	21.8	6.4	.45	.59	.72
	800	27.2	8.0	.46	.60	.74	25.8	7.6	.46	.61	.74	24.4	7.2	.46	.62	.78	23.0	6.7	.47	.63	.80
	1000	28.2	8.3	.48	.64	.80	26.8	7.9	.48	.65	.83	25.4	7.4	.49	.67	.85	23.6	6.9	.50	.69	.88

NOTE: Values based on 0.50" w.c. external static pressure

2 TON - RPGEV-71524 (1ST STAGE)																					
ENTERING WET BULB TEMP.	TOTAL AIR VOLUME	OUTDOOR AIR TEMPERATURE ENTERING OUTDOOR COIL																			
		75°F					85°F					95°F					105°F				
		TOTAL COOL CAP.	COMP. MOTOR INPUT	SENSIBLE TO TOTAL RATIO (S/T)			TOTAL COOL CAP.	COMP. MOTOR INPUT	SENSIBLE TO TOTAL RATIO (S/T)			TOTAL COOL CAP.	COMP. MOTOR INPUT	SENSIBLE TO TOTAL RATIO (S/T)			TOTAL COOL CAP.	COMP. MOTOR INPUT	SENSIBLE TO TOTAL RATIO (S/T)		
				DRY BULB					DRY BULB					DRY BULB					DRY BULB		
CFM	KBTUH	KW	75°F	80°F	85°F	KBTUH	KW	75°F	80°F	85°F	KBTUH	KW	75°F	80°F	85°F	KBTUH	KW	75°F	80°F	85°F	
63°F	440	18.6	5.5	.71	.84	.96	17.8	5.2	.72	.85	.98	16.9	5.0	.74	.87	1.00	15.9	4.7	.76	.90	1.00
	560	19.8	5.8	.77	.91	1.00	18.9	5.5	.78	.93	1.00	17.9	5.2	.80	.96	1.00	16.8	4.9	.82	.99	1.00
	720	21.0	6.2	.83	1.00	1.00	20.0	5.9	.85	1.00	1.00	19.1	5.6	.88	1.00	1.00	18.1	5.3	.91	1.00	1.00
67°F	440	19.8	5.8	.57	.69	.80	18.9	5.5	.57	.70	.82	18.0	5.3	.59	.71	.84	16.9	5.0	.60	.74	.87
	560	21.0	6.2	.60	.74	.87	20.0	5.9	.61	.76	.90	19.0	5.6	.62	.77	.92	17.7	5.2	.63	.79	.96
	720	22.0	6.4	.64	.81	.97	21.0	6.2	.65	.83	.99	19.9	5.8	.66	.85	1.00	18.6	5.5	.69	.89	1.00
71°F	440	20.8	6.1	.43	.55	.66	20.0	5.9	.43	.56	.67	19.0	5.6	.44	.57	.69	17.8	5.2	.45	.58	.71
	560	22.0	6.4	.45	.58	.72	21.2	6.2	.45	.60	.73	20.0	5.9	.46	.61	.75	18.8	5.5	.46	.62	.77
	720	23.2	6.8	.47	.62	.78	22.2	6.5	.47	.64	.80	21.0	6.2	.49	.66	.83	19.6	5.7	.48	.67	.86

NOTE: Values based on 0.58" w.c. external static pressure

2 TON - RPGEV-71524 (2ND STAGE)																					
ENTERING WET BULB TEMP.	TOTAL AIR VOLUME	OUTDOOR AIR TEMPERATURE ENTERING OUTDOOR COIL																			
		85°F					95°F					105°F					115°F				
		TOTAL COOL CAP.	COMP. MOTOR INPUT	SENSIBLE TO TOTAL RATIO (S/T)			TOTAL COOL CAP.	COMP. MOTOR INPUT	SENSIBLE TO TOTAL RATIO (S/T)			TOTAL COOL CAP.	COMP. MOTOR INPUT	SENSIBLE TO TOTAL RATIO (S/T)			TOTAL COOL CAP.	COMP. MOTOR INPUT	SENSIBLE TO TOTAL RATIO (S/T)		
				DRY BULB					DRY BULB					DRY BULB					DRY BULB		
CFM	KBTUH	KW	75°F	80°F	85°F	KBTUH	KW	75°F	80°F	85°F	KBTUH	KW	75°F	80°F	85°F	KBTUH	KW	75°F	80°F	85°F	
63°F	600	23.0	6.7	.72	.84	.97	21.8	6.4	.73	.86	.99	20.8	6.1	.75	.88	1.00	19.6	5.7	.77	.91	1.00
	800	24.4	7.2	.78	.94	1.00	23.4	6.9	.79	.96	1.00	22.0	6.4	.82	.99	1.00	20.8	6.1	.85	1.00	1.00
	1000	25.6	7.5	.85	1.00	1.00	24.6	7.2	.87	1.00	1.00	23.4	6.9	.89	1.00	1.00	22.0	6.4	.93	1.00	1.00
67°F	600	24.2	7.1	.57	.69	.81	23.2	6.8	.58	.70	.83	22.0	6.4	.59	.72	.85	20.6	6.0	.60	.74	.88
	800	25.8	7.6	.61	.76	.90	24.6	7.2	.62	.78	.93	23.2	6.8	.63	.80	.95	21.8	6.4	.65	.82	.98
	1000	26.8	7.9	.64	.81	.99	25.6	7.5	.67	.85	1.00	24.2	7.1	.68	.87	1.00	22.6	6.6	.70	.91	1.00
71°F	600	25.4	7.4	.44	.56	.67	24.4	7.2	.44	.56	.68	23.0	6.7	.45	.57	.70	21.8	6.4	.45	.59	.72
	800	27.2	8.0	.46	.60	.74	25.8	7.6	.46	.61	.74	24.4	7.2	.46	.62	.78	23.0	6.7	.47	.63	.80
	1000	28.2	8.3	.48	.64	.80	26.8	7.9	.48	.65	.83	25.4	7.4	.49	.67	.85	23.6	6.9	.50	.69	.88

NOTE: Values based on 0.58" w.c. external static pressure

COOLING RATINGS

3 TON - RPGEV-71536 (1ST STAGE)																									
ENTERING WET BULB TEMP.	TOTAL AIR VOLUME	OUTDOOR AIR TEMPERATURE ENTERING OUTDOOR COIL																							
		75°F						85°F						95°F						105°F					
		TOTAL COOL CAP.	COMP. MOTOR INPUT	SENSIBLE TO TOTAL RATIO (S/T)			TOTAL COOL CAP.	COMP. MOTOR INPUT	SENSIBLE TO TOTAL RATIO (S/T)			TOTAL COOL CAP.	COMP. MOTOR INPUT	SENSIBLE TO TOTAL RATIO (S/T)			TOTAL COOL CAP.	COMP. MOTOR INPUT	SENSIBLE TO TOTAL RATIO (S/T)						
				DRY BULB					DRY BULB					DRY BULB					DRY BULB						
CFM	KBTUH	KW	75°F	80°F	85°F	KBTUH	KW	75°F	80°F	85°F	KBTUH	KW	75°F	80°F	85°F	KBTUH	KW	75°F	80°F	85°F					
63°F	720	27.2	8.0	.74	.88	1.00	25.8	7.6	.76	.90	1.00	24.6	7.2	.78	.93	1.00	23.2	6.8	.79	.96	1.00				
	840	28.2	8.3	.78	.93	1.00	26.8	7.9	.80	.95	1.00	25.4	7.4	.82	.98	1.00	24.0	7.0	.84	1.00	1.00				
	1000	29.2	8.6	.83	.99	1.00	27.8	8.1	.85	1.00	1.00	26.6	7.8	.87	1.00	1.00	25.2	7.4	.90	1.00	1.00				
67°F	720	28.8	8.4	.58	.72	.84	27.4	8.0	.60	.73	.87	26.0	7.6	.61	.75	.89	24.6	7.2	.62	.77	.92				
	840	29.8	8.7	.61	.76	.90	28.4	8.3	.62	.77	.92	26.8	7.9	.63	.79	.94	25.2	7.4	.64	.81	.98				
	1000	30.8	9.0	.64	.80	.96	29.4	8.6	.65	.82	.98	27.8	8.1	.67	.85	1.00	26.2	7.7	.68	.87	1.00				
71°F	720	30.4	8.9	.44	.57	.69	29.0	8.5	.45	.58	.71	27.6	8.1	.45	.59	.73	26.0	7.6	.46	.60	.75				
	840	31.4	9.2	.45	.59	.73	30.0	8.8	.46	.61	.75	28.4	8.3	.47	.62	.76	26.8	7.9	.47	.63	.79				
	1000	32.6	9.6	.47	.62	.78	31.0	9.1	.47	.64	.79	29.4	8.6	.48	.64	.82	27.6	8.1	.49	.67	.85				

NOTE: Values based on 0.50" w.c. external static pressure

3 TON - RPGEV-71536 (2ND STAGE)																									
ENTERING WET BULB TEMP.	TOTAL AIR VOLUME	OUTDOOR AIR TEMPERATURE ENTERING OUTDOOR COIL																							
		85°F						95°F						105°F						115°F					
		TOTAL COOL CAP.	COMP. MOTOR INPUT	SENSIBLE TO TOTAL RATIO (S/T)			TOTAL COOL CAP.	COMP. MOTOR INPUT	SENSIBLE TO TOTAL RATIO (S/T)			TOTAL COOL CAP.	COMP. MOTOR INPUT	SENSIBLE TO TOTAL RATIO (S/T)			TOTAL COOL CAP.	COMP. MOTOR INPUT	SENSIBLE TO TOTAL RATIO (S/T)						
				DRY BULB					DRY BULB					DRY BULB					DRY BULB						
CFM	KBTUH	KW	75°F	80°F	85°F	KBTUH	KW	75°F	80°F	85°F	KBTUH	KW	75°F	80°F	85°F	KBTUH	KW	75°F	80°F	85°F					
63°F	1000	35.0	10.3	.74	.88	1.00	33.4	9.8	.76	.90	1.00	31.6	9.3	.78	.93	1.00	29.6	8.7	.80	.96	1.00				
	1200	36.4	10.7	.79	.94	1.00	34.6	10.1	.81	.97	1.00	32.8	9.6	.82	.99	1.00	30.8	9.0	.85	1.00	1.00				
	1400	37.4	11.0	.83	.99	1.00	35.6	10.4	.85	1.00	1.00	34.0	10.0	.87	1.00	1.00	32.0	9.4	.91	1.00	1.00				
67°F	1000	37.0	10.8	.59	.72	.85	35.2	10.3	.60	.73	.87	33.4	9.8	.61	.76	.90	31.2	9.1	.62	.78	.93				
	1200	38.5	11.3	.61	.77	.91	36.4	10.7	.63	.78	.93	34.4	10.1	.64	.80	.96	32.2	9.4	.65	.83	.99				
	1400	39.5	11.6	.64	.81	.97	37.2	10.9	.65	.83	.99	35.2	10.3	.67	.85	1.00	32.8	9.6	.69	.89	1.00				
71°F	1000	39.0	11.4	.44	.57	.70	37.0	10.8	.45	.58	.71	35.0	10.3	.45	.60	.73	32.8	9.6	.46	.61	.76				
	1200	40.0	11.7	.46	.60	.74	38.5	11.3	.47	.61	.76	36.2	10.6	.47	.63	.78	33.8	9.9	.48	.64	.81				
	1400	41.5	12.2	.47	.63	.79	39.0	11.4	.48	.64	.81	37.0	10.8	.48	.66	.84	34.6	10.1	.49	.68	.87				

NOTE: Values based on 0.50" w.c. external static pressure

3 TON - RPGEV-71536 (1ST STAGE)																									
ENTERING WET BULB TEMP.	TOTAL AIR VOLUME	OUTDOOR AIR TEMPERATURE ENTERING OUTDOOR COIL																							
		75°F						85°F						95°F						105°F					
		TOTAL COOL CAP.	COMP. MOTOR INPUT	SENSIBLE TO TOTAL RATIO (S/T)			TOTAL COOL CAP.	COMP. MOTOR INPUT	SENSIBLE TO TOTAL RATIO (S/T)			TOTAL COOL CAP.	COMP. MOTOR INPUT	SENSIBLE TO TOTAL RATIO (S/T)			TOTAL COOL CAP.	COMP. MOTOR INPUT	SENSIBLE TO TOTAL RATIO (S/T)						
				DRY BULB					DRY BULB					DRY BULB					DRY BULB						
CFM	KBTUH	KW	75°F	80°F	85°F	KBTUH	KW	75°F	80°F	85°F	KBTUH	KW	75°F	80°F	85°F	KBTUH	KW	75°F	80°F	85°F					
63°F	720	27.2	8.0	.74	.88	1.00	25.8	7.6	.76	.90	1.00	24.6	7.2	.78	.93	1.00	23.2	6.8	.79	.96	1.00				
	840	28.2	8.3	.78	.93	1.00	26.8	7.9	.80	.95	1.00	25.4	7.4	.82	.98	1.00	24.0	7.0	.84	1.00	1.00				
	1000	29.2	8.6	.83	.99	1.00	27.8	8.1	.85	1.00	1.00	26.6	7.8	.87	1.00	1.00	25.2	7.4	.90	1.00	1.00				
67°F	720	28.8	8.4	.58	.72	.84	27.4	8.0	.60	.73	.87	26.0	7.6	.61	.75	.89	24.6	7.2	.62	.77	.92				
	840	29.8	8.7	.61	.76	.90	28.4	8.3	.62	.77	.92	26.8	7.9	.63	.79	.94	25.2	7.4	.64	.81	.98				
	1000	30.8	9.0	.64	.80	.96	29.4	8.6	.65	.82	.98	27.8	8.1	.67	.85	1.00	26.2	7.7	.68	.87	1.00				
71°F	720	30.4	8.9	.44	.57	.69	29.0	8.5	.45	.58	.71	27.6	8.1	.45	.59	.73	26.0	7.6	.46	.60	.75				
	840	31.4	9.2	.45	.59	.73	30.0	8.8	.46	.61	.75	28.4	8.3	.47	.62	.76	26.8	7.9	.47	.63	.79				
	1000	32.6	9.6	.47	.62	.78	31.0	9.1	.47	.64	.79	29.4	8.6	.48	.64	.82	27.6	8.1	.49	.67	.85				

NOTE: Values based on 0.58" w.c. external static pressure

3 TON - RPGEV-71536 (2ND STAGE)																									
ENTERING WET BULB TEMP.	TOTAL AIR VOLUME	OUTDOOR AIR TEMPERATURE ENTERING OUTDOOR COIL																							
		85°F						95°F						105°F						115°F					
		TOTAL COOL CAP.	COMP. MOTOR INPUT	SENSIBLE TO TOTAL RATIO (S/T)			TOTAL COOL CAP.	COMP. MOTOR INPUT	SENSIBLE TO TOTAL RATIO (S/T)			TOTAL COOL CAP.	COMP. MOTOR INPUT	SENSIBLE TO TOTAL RATIO (S/T)			TOTAL COOL CAP.	COMP. MOTOR INPUT	SENSIBLE TO TOTAL RATIO (S/T)						
				DRY BULB					DRY BULB					DRY BULB					DRY BULB						
CFM	KBTUH	KW	75°F	80°F	85°F	KBTUH	KW	75°F	80°F	85°F	KBTUH	KW	75°F	80°F	85°F	KBTUH	KW	75°F	80°F	85°F					
63°F	1000	35.0	10.3	.74	.88	1.00	33.4	9.8	.76	.90	1.00	31.6	9.3	.78	.93	1.00	29.6	8.7	.80	.96	1.00				
	1200	36.4	10.7	.79	.94	1.00	34.6	10.1	.81	.97	1.00	32.8	9.6	.82	.99	1.00	30.8	9.0	.85	1.00	1.00				
	1400	37.4	11.0	.83	.99	1.00	35.6	10.4	.85	1.00	1.00	34.0	10.0	.87	1.00	1.00	32.0	9.4	.91	1.00	1.00				
67°F	1000	37.0	10.8	.59	.72	.85	35.2	10.3	.60	.73	.87	33.4	9.8	.61	.76	.90	31.2	9.1	.62	.78	.93				
	1200	38.5	11.3	.61	.77	.91	36.4	10.7	.63	.78	.93	34.4	10.1	.64	.80	.96	32.2	9.4	.65	.83	.99				
	1400	39.5	11.6	.64	.81	.97	37.2	10.9	.65	.83	.99	35.2	10.3	.67	.85	1.00	32.8	9.6	.69	.89	1.00				
71°F	1000	39.0	11.4	.44	.57	.70	37.0	10.8	.45	.58	.71	35.0	10.3	.45	.60	.73	32.8	9.6	.46	.61	.76				
	1200	40.0	11.7	.46	.60	.74	38.5	11.3	.47	.61	.76	36.2	10.6	.47	.63	.78	33.8	9.9	.48	.64	.81				
	1400	41.5	12.2	.47	.63	.79	39.0	11.4	.48	.64	.81	37.0	10.8	.48	.66	.84	34.6	10.1	.49	.68	.87				

NOTE: Values based on 0.58" w.c. external static pressure

COOLING RATINGS

4 TON - RPGEV-71548 (1ST STAGE)																					
ENTERING WET BULB TEMP.	TOTAL AIR VOLUME	OUTDOOR AIR TEMPERATURE ENTERING OUTDOOR COIL																			
		75°F					85°F					95°F					105°F				
		TOTAL COOL CAP.	COMP. MOTOR INPUT	SENSIBLE TO TOTAL RATIO (S/T)			TOTAL COOL CAP.	COMP. MOTOR INPUT	SENSIBLE TO TOTAL RATIO (S/T)			TOTAL COOL CAP.	COMP. MOTOR INPUT	SENSIBLE TO TOTAL RATIO (S/T)			TOTAL COOL CAP.	COMP. MOTOR INPUT	SENSIBLE TO TOTAL RATIO (S/T)		
				DRY BULB					DRY BULB					DRY BULB					DRY BULB		
CFM	KBTUH	KW	75°F	80°F	85°F	KBTUH	KW	75°F	80°F	85°F	KBTUH	KW	75°F	80°F	85°F	KBTUH	KW	75°F	80°F	85°F	
63°F	1000	36.4	10.7	.75	.89	1.00	34.6	10.1	.77	.91	1.00	32.6	9.6	.79	.94	1.00	30.4	8.9	.81	.98	1.00
	1120	37.4	11.0	.78	.93	1.00	35.6	10.4	.80	.95	1.00	33.6	9.8	.82	.98	1.00	31.4	9.2	.85	1.00	1.00
	1230	38.0	11.1	.80	.96	1.00	36.4	10.7	.82	.98	1.00	34.4	10.1	.84	1.00	1.00	32.2	9.4	.87	1.00	1.00
67°F	1000	38.5	11.3	.60	.73	.86	36.6	10.7	.60	.75	.88	34.6	10.1	.62	.77	.91	32.2	9.4	.63	.79	.94
	1120	39.5	11.6	.61	.75	.89	37.6	11.0	.62	.77	.92	35.4	10.4	.64	.79	.95	33.0	9.7	.65	.82	.98
	1230	40.5	11.9	.63	.78	.93	38.5	11.3	.64	.80	.95	36.0	10.6	.65	.82	.98	33.6	9.8	.67	.85	1.00
71°F	1000	40.5	11.9	.45	.58	.70	38.5	11.3	.45	.59	.72	36.4	10.7	.46	.60	.74	34.0	10.0	.47	.62	.76
	1120	41.5	12.2	.45	.60	.73	39.5	11.6	.46	.61	.75	37.4	11.0	.46	.62	.77	34.8	10.2	.47	.64	.80
	1230	42.5	12.5	.46	.61	.76	40.5	11.9	.46	.63	.77	38.0	11.1	.47	.64	.79	35.4	10.4	.48	.66	.83

NOTE: Values based on 0.50" w.c. external static pressure

4 TON - RPGEV-71548 (2ND STAGE)																					
ENTERING WET BULB TEMP.	TOTAL AIR VOLUME	OUTDOOR AIR TEMPERATURE ENTERING OUTDOOR COIL																			
		85°F					95°F					105°F					115°F				
		TOTAL COOL CAP.	COMP. MOTOR INPUT	SENSIBLE TO TOTAL RATIO (S/T)			TOTAL COOL CAP.	COMP. MOTOR INPUT	SENSIBLE TO TOTAL RATIO (S/T)			TOTAL COOL CAP.	COMP. MOTOR INPUT	SENSIBLE TO TOTAL RATIO (S/T)			TOTAL COOL CAP.	COMP. MOTOR INPUT	SENSIBLE TO TOTAL RATIO (S/T)		
				DRY BULB					DRY BULB					DRY BULB					DRY BULB		
CFM	KBTUH	KW	75°F	80°F	85°F	KBTUH	KW	75°F	80°F	85°F	KBTUH	KW	75°F	80°F	85°F	KBTUH	KW	75°F	80°F	85°F	
63°F	1400	47.0	13.8	.75	.89	1.00	45.0	13.2	.77	.91	1.00	42.5	12.5	.78	.93	1.00	40.0	11.7	.80	.96	1.00
	1600	48.5	14.2	.78	.93	1.00	46.0	13.5	.80	.95	1.00	44.0	12.9	.82	.98	1.00	41.0	12.0	.84	1.00	1.00
	1800	49.5	14.5	.81	.97	1.00	47.0	13.8	.83	.99	1.00	45.0	13.2	.85	1.00	1.00	42.5	12.5	.88	1.00	1.00
67°F	1400	49.5	14.5	.60	.73	.86	47.0	13.8	.60	.74	.88	45.0	13.2	.62	.76	.90	42.0	12.3	.63	.78	.93
	1600	51.0	14.9	.61	.76	.90	48.5	14.2	.62	.78	.92	46.0	13.5	.64	.80	.95	43.0	12.6	.65	.82	.98
	1800	52.0	15.2	.63	.79	.94	49.5	14.5	.64	.81	.97	47.0	13.8	.66	.83	.99	44.0	12.9	.67	.86	1.00
71°F	1400	51.5	15.1	.45	.58	.71	49.0	14.4	.46	.59	.72	47.0	13.8	.46	.60	.74	44.0	12.9	.47	.62	.76
	1600	53.0	15.5	.45	.60	.74	50.5	14.8	.46	.61	.75	48.0	14.1	.47	.63	.78	45.0	13.2	.47	.64	.80
	1800	54.0	15.8	.46	.62	.77	51.5	15.1	.47	.63	.79	49.0	14.4	.48	.65	.81	46.0	13.5	.48	.66	.84

NOTE: Values based on 0.50" w.c. external static pressure

4 TON - RPGEV-71548 (1ST STAGE)																					
ENTERING WET BULB TEMP.	TOTAL AIR VOLUME	OUTDOOR AIR TEMPERATURE ENTERING OUTDOOR COIL																			
		75°F					85°F					95°F					105°F				
		TOTAL COOL CAP.	COMP. MOTOR INPUT	SENSIBLE TO TOTAL RATIO (S/T)			TOTAL COOL CAP.	COMP. MOTOR INPUT	SENSIBLE TO TOTAL RATIO (S/T)			TOTAL COOL CAP.	COMP. MOTOR INPUT	SENSIBLE TO TOTAL RATIO (S/T)			TOTAL COOL CAP.	COMP. MOTOR INPUT	SENSIBLE TO TOTAL RATIO (S/T)		
				DRY BULB					DRY BULB					DRY BULB					DRY BULB		
CFM	KBTUH	KW	75°F	80°F	85°F	KBTUH	KW	75°F	80°F	85°F	KBTUH	KW	75°F	80°F	85°F	KBTUH	KW	75°F	80°F	85°F	
63°F	1000	36.4	10.7	.75	.89	1.00	34.6	10.1	.77	.91	1.00	32.6	9.6	.79	.94	1.00	30.4	8.9	.81	.98	1.00
	1120	37.4	11.0	.78	.93	1.00	35.6	10.4	.80	.95	1.00	33.6	9.8	.82	.98	1.00	31.4	9.2	.85	1.00	1.00
	1230	38.0	11.1	.80	.96	1.00	36.4	10.7	.82	.98	1.00	34.4	10.1	.84	1.00	1.00	32.2	9.4	.87	1.00	1.00
67°F	1000	38.5	11.3	.60	.73	.86	36.6	10.7	.60	.75	.88	34.6	10.1	.62	.77	.91	32.2	9.4	.63	.79	.94
	1120	39.5	11.6	.61	.75	.89	37.6	11.0	.62	.77	.92	35.4	10.4	.64	.79	.95	33.0	9.7	.65	.82	.98
	1230	40.5	11.9	.63	.78	.93	38.5	11.3	.64	.80	.95	36.0	10.6	.65	.82	.98	33.6	9.8	.67	.85	1.00
71°F	1000	40.5	11.9	.45	.58	.70	38.5	11.3	.45	.59	.72	36.4	10.7	.46	.60	.74	34.0	10.0	.47	.62	.76
	1120	41.5	12.2	.45	.60	.73	39.5	11.6	.46	.61	.75	37.4	11.0	.46	.62	.77	34.8	10.2	.47	.64	.80
	1230	42.5	12.5	.46	.61	.76	40.5	11.9	.46	.63	.77	38.0	11.1	.47	.64	.79	35.4	10.4	.48	.66	.83

NOTE: Values based on 0.58" w.c. external static pressure

4 TON - RPGEV-71548 (2ND STAGE)																					
ENTERING WET BULB TEMP.	TOTAL AIR VOLUME	OUTDOOR AIR TEMPERATURE ENTERING OUTDOOR COIL																			
		85°F					95°F					105°F					115°F				
		TOTAL COOL CAP.	COMP. MOTOR INPUT	SENSIBLE TO TOTAL RATIO (S/T)			TOTAL COOL CAP.	COMP. MOTOR INPUT	SENSIBLE TO TOTAL RATIO (S/T)			TOTAL COOL CAP.	COMP. MOTOR INPUT	SENSIBLE TO TOTAL RATIO (S/T)			TOTAL COOL CAP.	COMP. MOTOR INPUT	SENSIBLE TO TOTAL RATIO (S/T)		
				DRY BULB					DRY BULB					DRY BULB					DRY BULB		
CFM	KBTUH	KW	75°F	80°F	85°F	KBTUH	KW	75°F	80°F	85°F	KBTUH	KW	75°F	80°F	85°F	KBTUH	KW	75°F	80°F	85°F	
63°F	1400	47.0	13.8	.75	.89	1.00	45.0	13.2	.77	.91	1.00	42.5	12.5	.78	.93	1.00	40.0	11.7	.80	.96	1.00
	1600	48.5	14.2	.78	.93	1.00	46.0	13.5	.80	.95	1.00	44.0	12.9	.82	.98	1.00	41.0	12.0	.84	1.00	1.00
	1800	49.5	14.5	.81	.97	1.00	47.0	13.8	.83	.99	1.00	45.0	13.2	.85	1.00	1.00	42.5	12.5	.88	1.00	1.00
67°F	1400	49.5	14.5	.60	.73	.86	47.0	13.8	.60	.74	.88	45.0	13.2	.62	.76	.90	42.0	12.3	.63	.78	.93
	1600	51.0	14.9	.61	.76	.90	48.5	14.2	.62	.78	.92	46.0	13.5	.64	.80	.95	43.0	12.6	.65	.82	.98
	1800	52.0	15.2	.63	.79	.94	49.5	14.5	.64	.81	.97	47.0	13.8	.66	.83	.99	44.0	12.9	.67	.86	1.00
71°F	1400	51.5	15.1	.45	.58	.71	49.0	14.4	.46	.59	.72	47.0	13.8	.46	.60	.74	44.0	12.9	.47	.62	.76
	1600	53.0	15.5	.45	.60	.74	50.5	14.8	.46	.61	.75	48.0	14.1	.47	.63	.78	45.0	13.2	.47	.64	.80
	1800	54.0	15.8	.46	.62	.77	51.5	15.1	.47	.63	.79	49.0	14.4	.48	.65	.81	46.0	13.5	.48	.66	.84

NOTE: Values based on 0.58" w.c. external static pressure

COOLING RATINGS

5 TON - RPGEV-71560 (1ST STAGE)																					
ENTERING WET BULB TEMP.	TOTAL AIR VOLUME	OUTDOOR AIR TEMPERATURE ENTERING OUTDOOR COIL																			
		75°F					85°F					95°F					105°F				
		TOTAL COOL CAP.	COMP. MOTOR INPUT	SENSIBLE TO TOTAL RATIO (S/T)			TOTAL COOL CAP.	COMP. MOTOR INPUT	SENSIBLE TO TOTAL RATIO (S/T)			TOTAL COOL CAP.	COMP. MOTOR INPUT	SENSIBLE TO TOTAL RATIO (S/T)			TOTAL COOL CAP.	COMP. MOTOR INPUT	SENSIBLE TO TOTAL RATIO (S/T)		
				DRY BULB					DRY BULB					DRY BULB					DRY BULB		
CFM	KBTUH	KW	75°F	80°F	85°F	KBTUH	KW	75°F	80°F	85°F	KBTUH	KW	75°F	80°F	85°F	KBTUH	KW	75°F	80°F	85°F	
63°F	1130	45.5	13.3	.73	.85	.97	43.5	12.7	.74	.87	.99	41.5	12.2	.75	.89	1.00	39.0	11.4	.77	.92	1.00
	1260	47.0	13.8	.74	.88	1.00	45.0	13.2	.76	.90	1.00	42.5	12.5	.78	.92	1.00	40.0	11.7	.80	.96	1.00
	1390	48.0	14.1	.77	.91	1.00	46.0	13.5	.78	.93	1.00	43.5	12.7	.80	.96	1.00	40.5	11.9	.82	.99	1.00
67°F	1130	48.0	14.1	.58	.70	.82	46.0	13.5	.59	.71	.83	43.5	12.7	.59	.73	.86	41.0	12.0	.61	.75	.89
	1260	49.5	14.5	.59	.72	.85	47.5	13.9	.60	.73	.87	45.0	13.2	.61	.75	.89	42.0	12.3	.62	.77	.92
	1390	50.5	14.8	.60	.74	.88	48.5	14.2	.61	.76	.90	46.0	13.5	.62	.78	.92	43.0	12.6	.64	.80	.95
71°F	1130	50.5	14.8	.44	.56	.68	48.5	14.2	.44	.57	.69	46.0	13.5	.45	.58	.70	43.0	12.6	.46	.59	.72
	1260	52.0	15.2	.45	.58	.70	50.0	14.7	.45	.58	.71	47.0	13.8	.45	.60	.73	44.5	13.0	.46	.61	.75
	1390	53.0	15.5	.45	.59	.72	51.0	14.9	.45	.60	.73	48.5	14.2	.46	.61	.75	45.5	13.3	.47	.63	.78

NOTE: Values based on 0.50" w.c. external static pressure

5 TON - RPGEV-71548 (2ND STAGE)																					
ENTERING WET BULB TEMP.	TOTAL AIR VOLUME	OUTDOOR AIR TEMPERATURE ENTERING OUTDOOR COIL																			
		85°F					95°F					105°F					115°F				
		TOTAL COOL CAP.	COMP. MOTOR INPUT	SENSIBLE TO TOTAL RATIO (S/T)			TOTAL COOL CAP.	COMP. MOTOR INPUT	SENSIBLE TO TOTAL RATIO (S/T)			TOTAL COOL CAP.	COMP. MOTOR INPUT	SENSIBLE TO TOTAL RATIO (S/T)			TOTAL COOL CAP.	COMP. MOTOR INPUT	SENSIBLE TO TOTAL RATIO (S/T)		
				DRY BULB					DRY BULB					DRY BULB					DRY BULB		
CFM	KBTUH	KW	75°F	80°F	85°F	KBTUH	KW	75°F	80°F	85°F	KBTUH	KW	75°F	80°F	85°F	KBTUH	KW	75°F	80°F	85°F	
63°F	1600	58.0	17.0	.73	.86	.98	55.5	16.3	.74	.88	1.00	52.5	15.4	.76	.90	1.00	49.5	14.5	.78	.93	1.00
	1800	59.5	17.4	.75	.89	1.00	57.0	16.7	.77	.91	1.00	54.0	15.8	.79	.94	1.00	51.0	14.9	.81	.97	1.00
	1900	60.0	17.6	.76	.91	1.00	57.5	16.9	.78	.93	1.00	54.5	16.0	.80	.96	1.00	51.5	15.1	.82	.98	1.00
67°F	1600	61.0	17.9	.58	.71	.83	58.0	17.0	.59	.72	.85	55.5	16.3	.60	.74	.87	52.0	15.2	.61	.76	.89
	1800	62.5	18.3	.60	.73	.86	59.5	17.4	.60	.75	.88	56.5	16.6	.62	.76	.91	53.5	15.7	.63	.78	.94
	1900	63.0	18.5	.60	.74	.88	60.5	17.7	.61	.76	.90	57.5	16.9	.63	.78	.92	54.0	15.8	.64	.80	.96
71°F	1600	64.0	18.8	.44	.57	.69	61.0	17.9	.45	.58	.70	58.0	17.0	.45	.59	.71	54.5	16.0	.46	.60	.73
	1800	65.5	19.2	.45	.58	.71	62.5	18.3	.45	.59	.72	59.5	17.4	.46	.60	.74	56.0	16.4	.46	.62	.76
	1900	66.5	19.5	.45	.59	.72	63.0	18.5	.46	.60	.74	60.0	17.6	.46	.61	.76	56.5	16.6	.47	.63	.78

NOTE: Values based on 0.50" w.c. external static pressure

5 TON - RPGEV-71560 (1ST STAGE)																					
ENTERING WET BULB TEMP.	TOTAL AIR VOLUME	OUTDOOR AIR TEMPERATURE ENTERING OUTDOOR COIL																			
		75°F					85°F					95°F					105°F				
		TOTAL COOL CAP.	COMP. MOTOR INPUT	SENSIBLE TO TOTAL RATIO (S/T)			TOTAL COOL CAP.	COMP. MOTOR INPUT	SENSIBLE TO TOTAL RATIO (S/T)			TOTAL COOL CAP.	COMP. MOTOR INPUT	SENSIBLE TO TOTAL RATIO (S/T)			TOTAL COOL CAP.	COMP. MOTOR INPUT	SENSIBLE TO TOTAL RATIO (S/T)		
				DRY BULB					DRY BULB					DRY BULB					DRY BULB		
CFM	KBTUH	KW	75°F	80°F	85°F	KBTUH	KW	75°F	80°F	85°F	KBTUH	KW	75°F	80°F	85°F	KBTUH	KW	75°F	80°F	85°F	
63°F	1130	45.5	13.3	.73	.85	.97	43.5	12.7	.74	.87	.99	41.5	12.2	.75	.89	1.00	39.0	11.4	.77	.92	1.00
	1260	47.0	13.8	.74	.88	1.00	45.0	13.2	.76	.90	1.00	42.5	12.5	.78	.92	1.00	40.0	11.7	.80	.96	1.00
	1390	48.0	14.1	.77	.91	1.00	46.0	13.5	.78	.93	1.00	43.5	12.7	.80	.96	1.00	40.5	11.9	.82	.99	1.00
67°F	1130	48.0	14.1	.58	.70	.82	46.0	13.5	.59	.71	.83	43.5	12.7	.59	.73	.86	41.0	12.0	.61	.75	.89
	1260	49.5	14.5	.59	.72	.85	47.5	13.9	.60	.73	.87	45.0	13.2	.61	.75	.89	42.0	12.3	.62	.77	.92
	1390	50.5	14.8	.60	.74	.88	48.5	14.2	.61	.76	.90	46.0	13.5	.62	.78	.92	43.0	12.6	.64	.80	.95
71°F	1130	50.5	14.8	.44	.56	.68	48.5	14.2	.44	.57	.69	46.0	13.5	.45	.58	.70	43.0	12.6	.46	.59	.72
	1260	52.0	15.2	.45	.58	.70	50.0	14.7	.45	.58	.71	47.0	13.8	.45	.60	.73	44.5	13.0	.46	.61	.75
	1390	53.0	15.5	.45	.59	.72	51.0	14.9	.45	.60	.73	48.5	14.2	.46	.61	.75	45.5	13.3	.47	.63	.78

NOTE: Values based on 0.58" w.c. external static pressure

5 TON - RPGEV-71548 (2ND STAGE)																					
ENTERING WET BULB TEMP.	TOTAL AIR VOLUME	OUTDOOR AIR TEMPERATURE ENTERING OUTDOOR COIL																			
		85°F					95°F					105°F					115°F				
		TOTAL COOL CAP.	COMP. MOTOR INPUT	SENSIBLE TO TOTAL RATIO (S/T)			TOTAL COOL CAP.	COMP. MOTOR INPUT	SENSIBLE TO TOTAL RATIO (S/T)			TOTAL COOL CAP.	COMP. MOTOR INPUT	SENSIBLE TO TOTAL RATIO (S/T)			TOTAL COOL CAP.	COMP. MOTOR INPUT	SENSIBLE TO TOTAL RATIO (S/T)		
				DRY BULB					DRY BULB					DRY BULB					DRY BULB		
CFM	KBTUH	KW	75°F	80°F	85°F	KBTUH	KW	75°F	80°F	85°F	KBTUH	KW	75°F	80°F	85°F	KBTUH	KW	75°F	80°F	85°F	
63°F	1600	58.0	17.0	.73	.86	.98	55.5	16.3	.74	.88	1.00	52.5	15.4	.76	.90	1.00	49.5	14.5	.78	.93	1.00
	1800	59.5	17.4	.75	.89	1.00	57.0	16.7	.77	.91	1.00	54.0	15.8	.79	.94	1.00	51.0	14.9	.81	.97	1.00
	1900	60.0	17.6	.76	.91	1.00	57.5	16.9	.78	.93	1.00	54.5	16.0	.80	.96	1.00	51.5	15.1	.82	.98	1.00
67°F	1600	61.0	17.9	.58	.71	.83	58.0	17.0	.59	.72	.85	55.5	16.3	.60	.74	.87	52.0	15.2	.61	.76	.89
	1800	62.5	18.3	.60	.73	.86	59.5	17.4	.60	.75	.88	56.5	16.6	.62	.76	.91	53.5	15.7	.63	.78	.94
	1900	63.0	18.5	.60	.74	.88	60.5	17.7	.61	.76	.90	57.5	16.9	.63	.78	.92	54.0	15.8	.64	.80	.96
71°F	1600	64.0	18.8	.44	.57	.69	61.0	17.9	.45	.58	.70	58.0	17.0	.45	.59	.71	54.5	16.0	.46	.60	.73
	1800	65.5	19.2	.45	.58	.71	62.5	18.3	.45	.59	.72	59.5	17.4	.46	.60	.74	56.0	16.4	.46	.62	.76
	1900	66.5	19.5	.45	.59	.72	63.0	18.5	.46	.60	.74	60.0	17.6	.46	.61	.76	56.5	16.6	.47	.63	.78

NOTE: Values based on 0.58" w.c. external static pressure

BLOWER DATA

RPGEV-71524 BLOWER PERFORMANCE 0 THROUGH 0.80 IN. W.G. EXTERNAL STATIC PRESSURE RANGE												
"ADJUST" JUMPER SETTING	BLOWER CONTROL JUMPER SPEED POSITIONS											
	"COOL" SPEED - CFM				"HEAT" SPEED - CFM				"CONTINUOUS FAN" SPEED - CFM			
	A	B	C	D	A	B	C	D	A	B	C	D
+	1100	880	660	440	1100	1000	900	815	550	440	330	220
NORM	1000	800	600	400	1100	1000	900	815	500	400	300	200
-	900	720	540	360	1100	1000	900	815	450	360	270	180

NOTE - All air data is measured external to unit without air filters.

NOTE - 1st Stage airflow is 70% of 2nd Stage airflow (full capacity) in cooling mode. In heating mode, low stage airflow is optimized for a 40°F temperature rise.

RPGEV-71536 BLOWER PERFORMANCE 0 THROUGH 0.80 IN. W.G. EXTERNAL STATIC PRESSURE RANGE												
"ADJUST" JUMPER SETTING	BLOWER CONTROL JUMPER SPEED POSITIONS											
	"COOL" SPEED - CFM				"HEAT" SPEED - CFM				"CONTINUOUS FAN" SPEED - CFM			
	A	B	C	D	A	B	C	D	A	B	C	D
+	1540	1320	1100	880	1400	1200	1100	975	770	660	550	440
NORM	1400	1200	1000	800	1400	1200	1100	975	700	600	500	400
-	1260	1080	900	720	1400	1200	1100	975	630	540	450	360

NOTE - All air data is measured external to unit without air filters.

NOTE - 1st Stage airflow is 70% of 2nd Stage airflow (full capacity) in cooling mode. In heating mode, low stage airflow is optimized for a 40°F temperature rise.

RPGEV-71548 BLOWER PERFORMANCE 0 THROUGH 0.80 IN. W.G. EXTERNAL STATIC PRESSURE RANGE												
"ADJUST" JUMPER SETTING	BLOWER CONTROL JUMPER SPEED POSITIONS											
	"COOL" SPEED - CFM				"HEAT" SPEED - CFM				"CONTINUOUS FAN" SPEED - CFM			
	A	B	C	D	A	B	C	D	A	B	C	D
+	1980	1760	1540	1320	1350	1200	1100	1000	990	880	770	660
NORM	1800	1600	1400	1200	1350	1200	1100	1000	900	800	700	600
-	1620	1440	1260	1080	1350	1200	1100	1000	810	720	630	540

NOTE - All air data is measured external to unit without air filters.

NOTE - 1st Stage airflow is 70% of 2nd Stage airflow (full capacity) in cooling mode. In heating mode, low stage airflow is optimized for a 40°F temperature rise.

RPGEV-71560 BLOWER PERFORMANCE 0 THROUGH 0.80 IN. W.G. EXTERNAL STATIC PRESSURE RANGE												
"ADJUST" JUMPER SETTING	BLOWER CONTROL JUMPER SPEED POSITIONS											
	"COOL" SPEED - CFM				"HEAT" SPEED - CFM				"CONTINUOUS FAN" SPEED - CFM			
	A	B	C	D	A	B	C	D	A	B	C	D
+	2200	1980	1760	1540	1480	1380	1280	1180	1100	990	880	770
NORM	2000	1800	1600	1400	1480	1380	1280	1180	1000	900	800	700
-	1800	1620	1440	1260	1480	1380	1280	1180	900	810	720	630

NOTE - All air data is measured external to unit without air filters.

NOTE - 1st Stage airflow is 70% of 2nd Stage airflow (full capacity) in cooling mode. In heating mode, low stage airflow is optimized for a 40°F temperature rise.

INSTALLATION CLEARANCES		
	IN.	MM
Front (heat exchanger access)	24	610
Right Side (blower access)	24	610
Left Side (evaporator coil access)	24	610
Back	0	0
Top	48	1219

MINIMUM CLEARANCE TO COMBUSTIBLE MATERIAL		
	IN.	MM
Front	0	0
Back	0	0
Right Side (vent cover)	12	305
Left Side	0	0
Top	0	0
Below Unit	0	0

ACCESSORY AIR RESISTANCE DATA - in. w.g.

AIR VOLUME CFM	RECTANGULAR TO ROUND DUCT ADAPTOR KITS					
	DOWNFLOW		HORIZONTAL			
	14 in. Diameter		14 in. Diameter		16 in. Diameter	18 in. Diameter
	24, 30, 36	42, 48, 60	24, 30, 36	42, 48, 60	42, 48, 60	42, 48, 60
500	0.03	---	0.04	---	---	---
600	0.05	---	0.07	---	---	---
700	0.08	0.13	0.08	0.13	---	---
800	0.10	0.17	0.12	0.16	---	---
900	0.12	0.21	0.15	0.21	---	---
1000	0.17	0.24	0.19	0.25	0.11	0.03
1100	0.18	0.30	0.23	0.30	0.11	0.03
1200	0.20	0.36	0.29	0.37	0.13	0.03
1300	0.26	0.43	0.31	0.43	0.17	0.03
1400	0.31	0.50	0.39	0.51	0.20	0.03
1500	---	0.57	---	0.57	0.21	0.05
1600	---	0.63	---	0.65	0.26	0.05
1700	---	0.71	---	0.72	0.30	0.06
1800	---	0.80	---	0.81	0.30	0.06
1900	---	0.91	---	0.90	0.40	0.06
2000	---	0.99	---	1.01	0.41	0.06

DIMENSIONS (IN.) - SMALL BASE (24, 36)

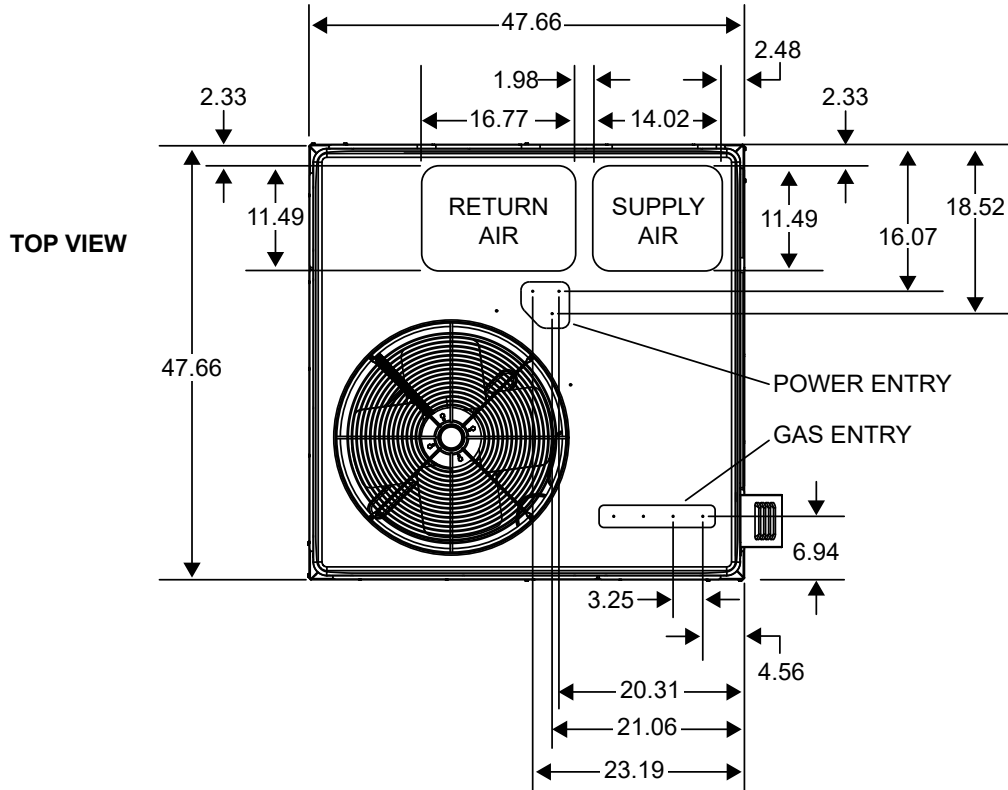

SIDE VIEWS

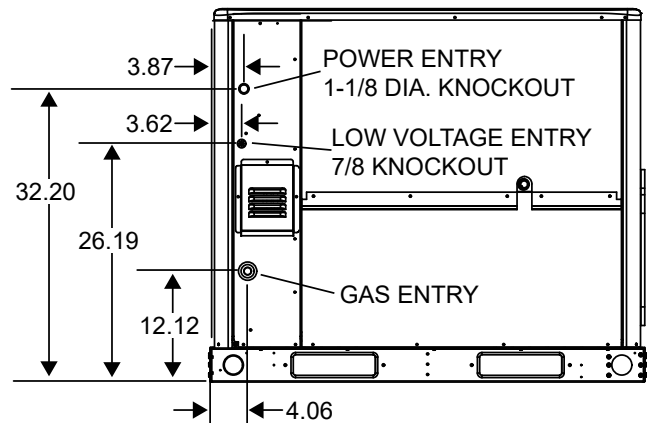
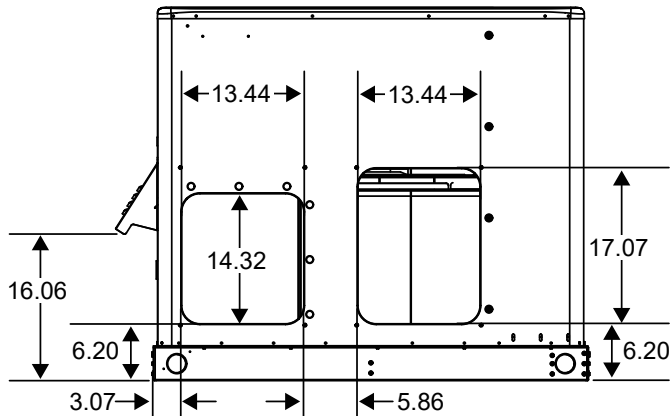
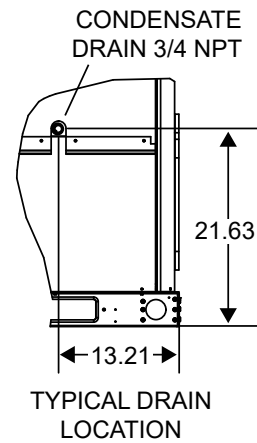
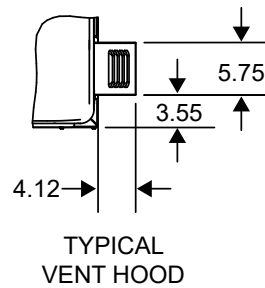
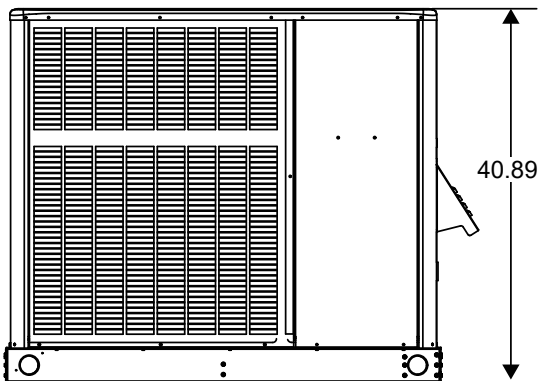

DIMENSIONS (IN.) - LARGE BASE (48, 60)

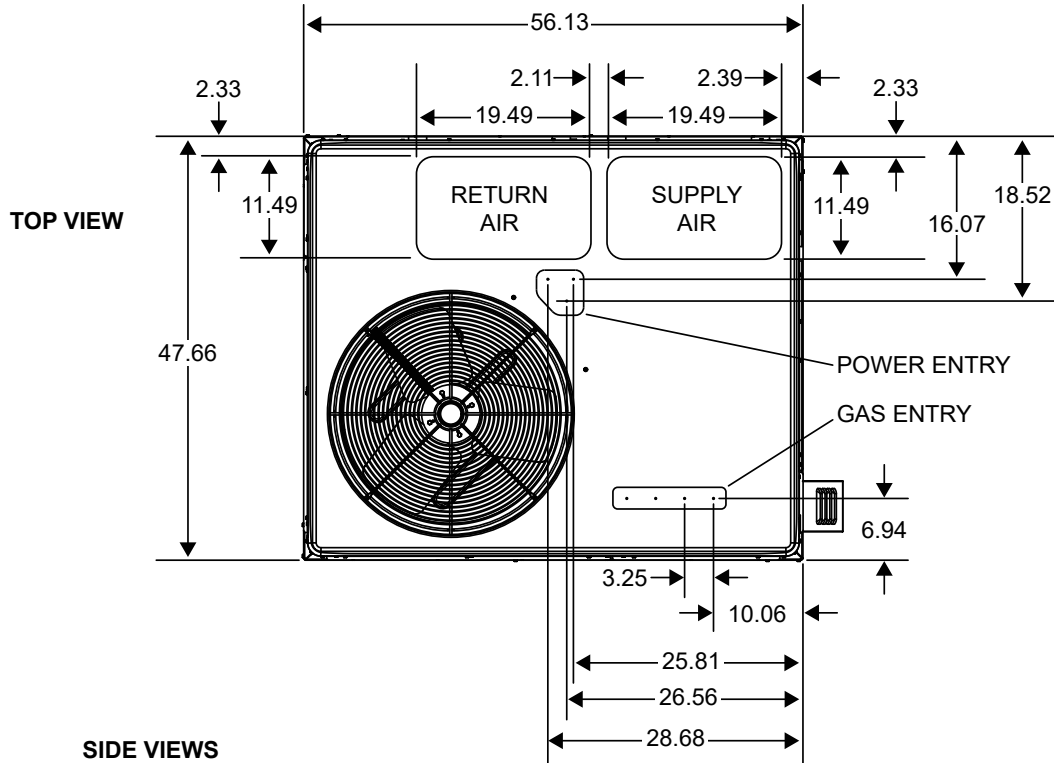

SIDE VIEWS

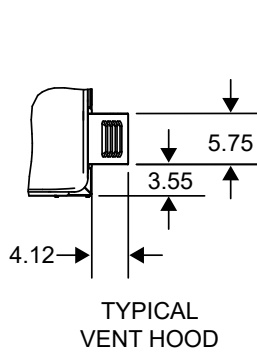
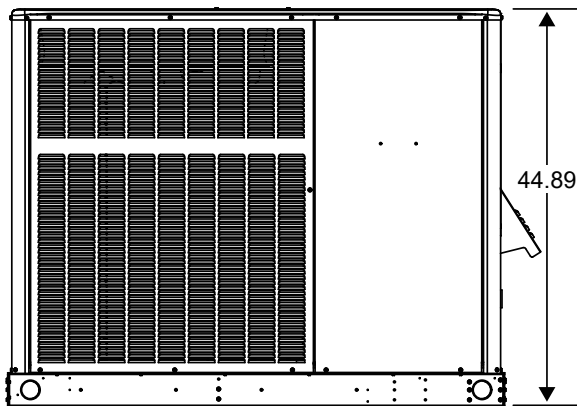

TYPICAL VENT HOOD

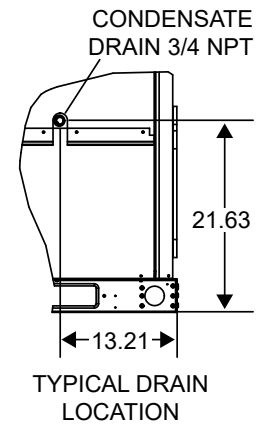

TYPICAL DRAIN LOCATION

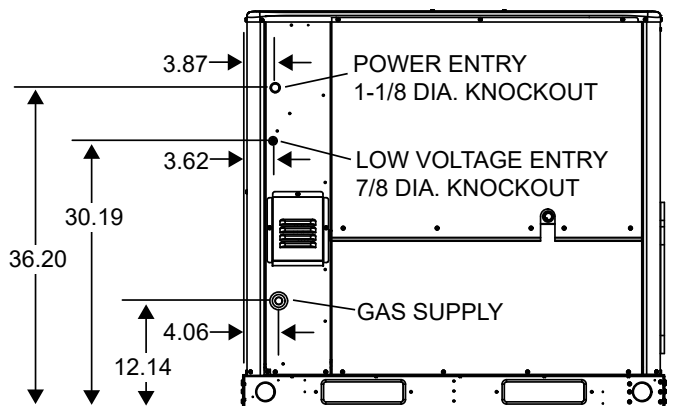
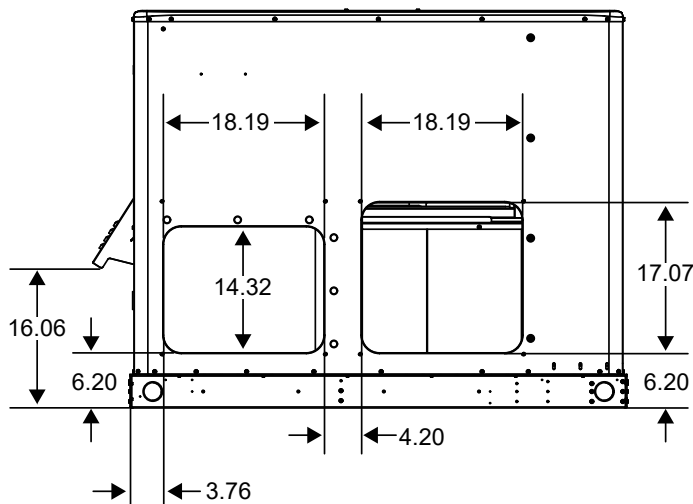

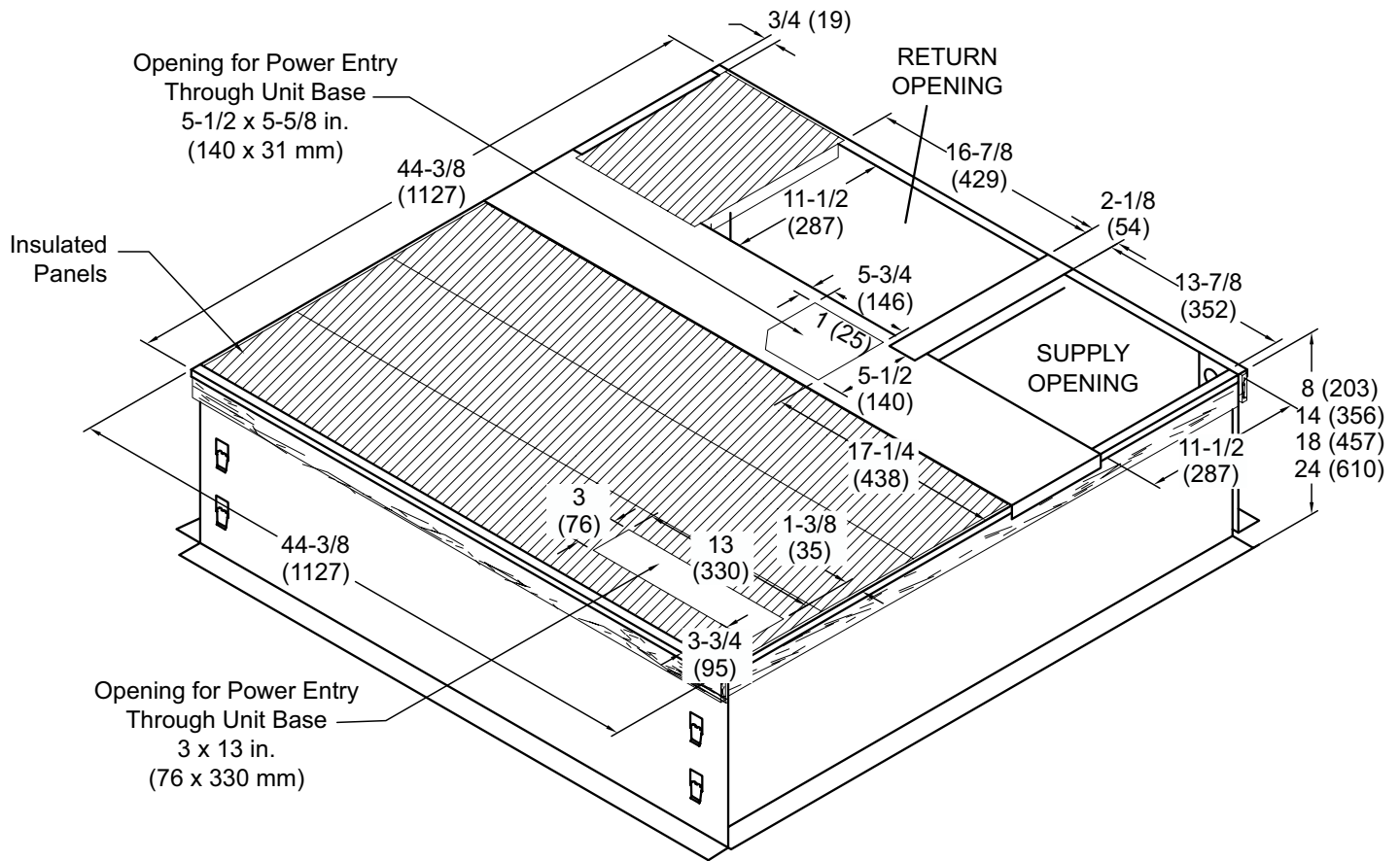
ROOF CURB DIMENSIONS - SMALL BASE (24, 36)

NOTE - If bottom entry is used, condensate from the heat exchanger may leak during warm ambient temperatures in humid climates. Ensure that bottom entry is watertight, if used.

NOTE - Roof deck may be omitted within confines of curb.

NOTE - All Curbs::

- IBC 2018 compliant
- CBC 2019 compliant
- Seismic rating - SDS 2.0g, z/h=1, Ip=1.5
- Wind rating - 240 mph (Lateral), 214 mph (Uplift)
- Maximum load rating - 800 lbs.
- Tool-less filter access panels NOT for seismic-rated applications

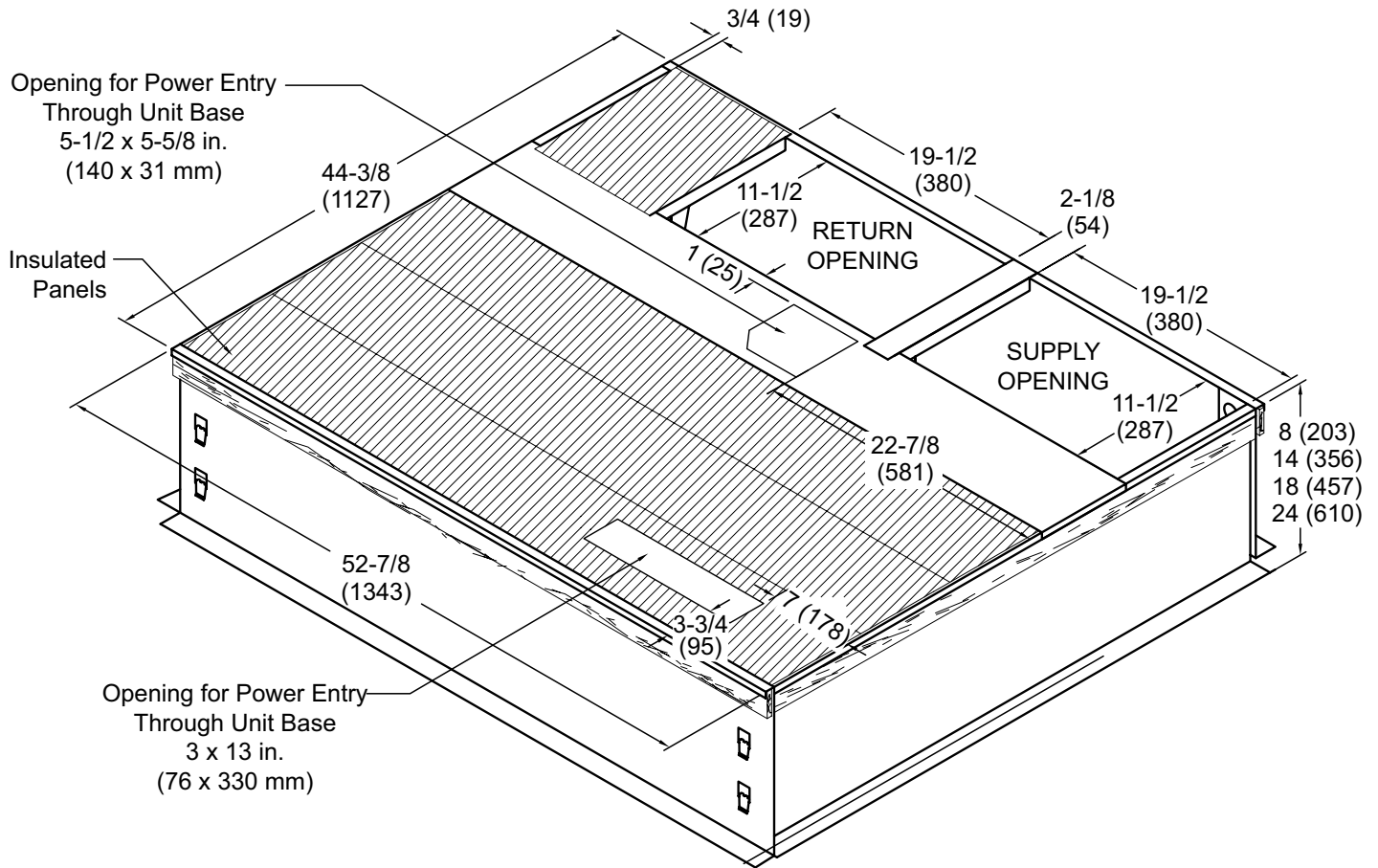
ROOF CURB DIMENSIONS - LARGE BASE (48, 60)

NOTE - If bottom entry is used, condensate from the heat exchanger may leak during warm ambient temperatures in humid climates. Ensure that bottom entry is watertight, if used.

NOTE - Roof deck may be omitted within confines of curb.

NOTE - All Curbs::

- IBC 2018 compliant
- CBC 2019 compliant
- Seismic rating - SDS 2.0g, z/h=1, Ip=1.5
- Wind rating - 240 mph (Lateral), 214 mph (Uplift)
- Maximum load rating - 800 lbs.
- Tool-less filter access panels NOT for seismic-rated applications

ADJUSTABLE CURB (KNOCK-DOWN STYLE) DIMENSIONS - SMALL BASE (24, 36)

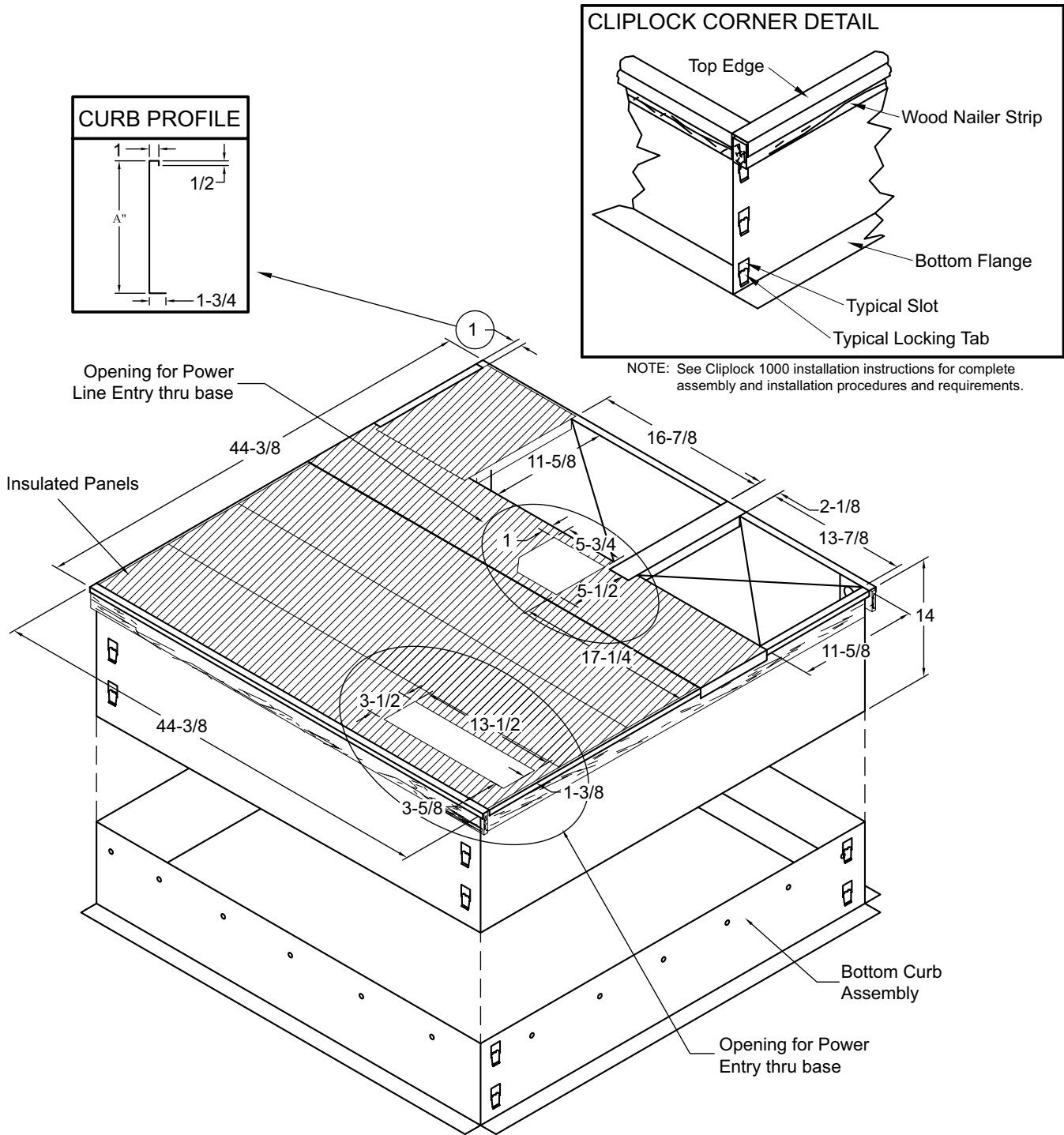

NOTE - If bottom entry is used, condensate from the heat exchanger may leak during warm ambient temperatures in humid climates. Ensure that bottom entry is watertight, if used.

NOTE - Roof deck may be omitted within confines of curb.

NOTE - All Curbs::

- IBC 2018 compliant
- CBC 2019 compliant
- Seismic rating - SDS 2.0g, z/h=1, I_p=1.5
- Wind rating - 240 mph (Lateral), 214 mph (Uplift)
- Maximum load rating - 800 lbs.
- Tool-less filter access panels NOT for seismic-rated applications

ADJUSTABLE CURB (KNOCK-DOWN STYLE) DIMENSIONS - LARGE BASE (48, 60)

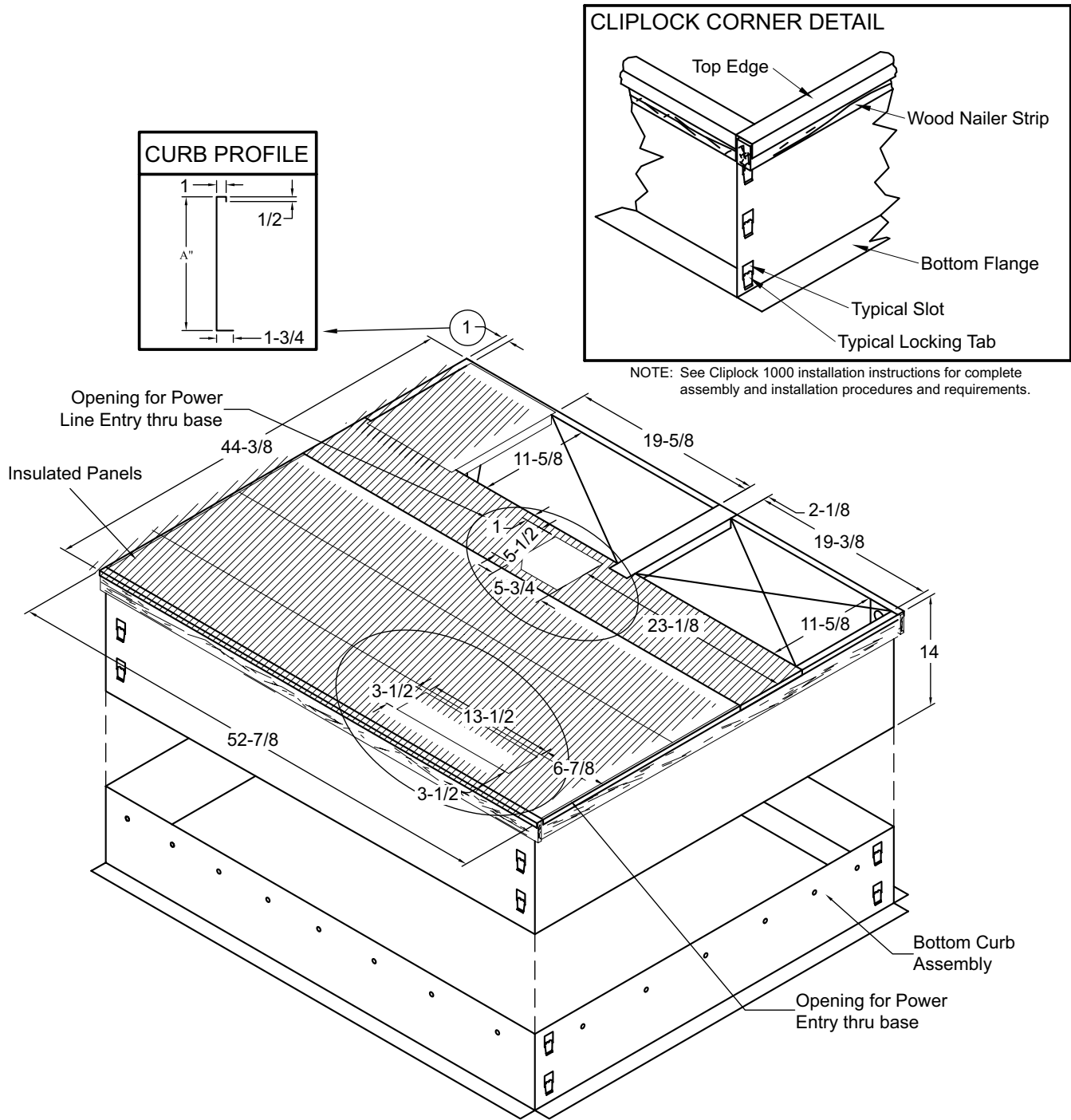

NOTE - If bottom entry is used, condensate from the heat exchanger may leak during warm ambient temperatures in humid climates. Ensure that bottom entry is watertight, if used.

NOTE - Roof deck may be omitted within confines of curb.

NOTE - All Curbs::

- IBC 2018 compliant
- CBC 2019 compliant
- Seismic rating - SDS 2.0g, z/h=1, Ip=1.5
- Wind rating - 240 mph (Lateral), 214 mph (Uplift)
- Maximum load rating - 800 lbs.
- Tool-less filter access panels NOT for seismic-rated applications

ADJUSTABLE CURB (WELDED STYLE) DIMENSIONS

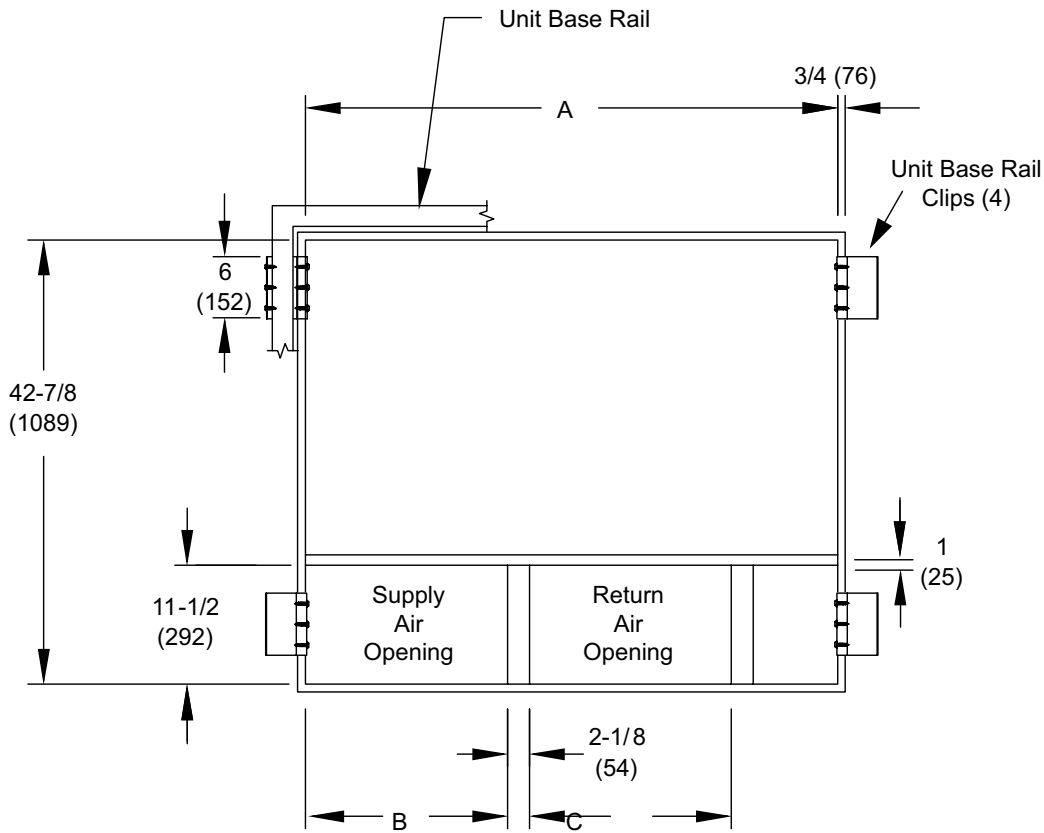
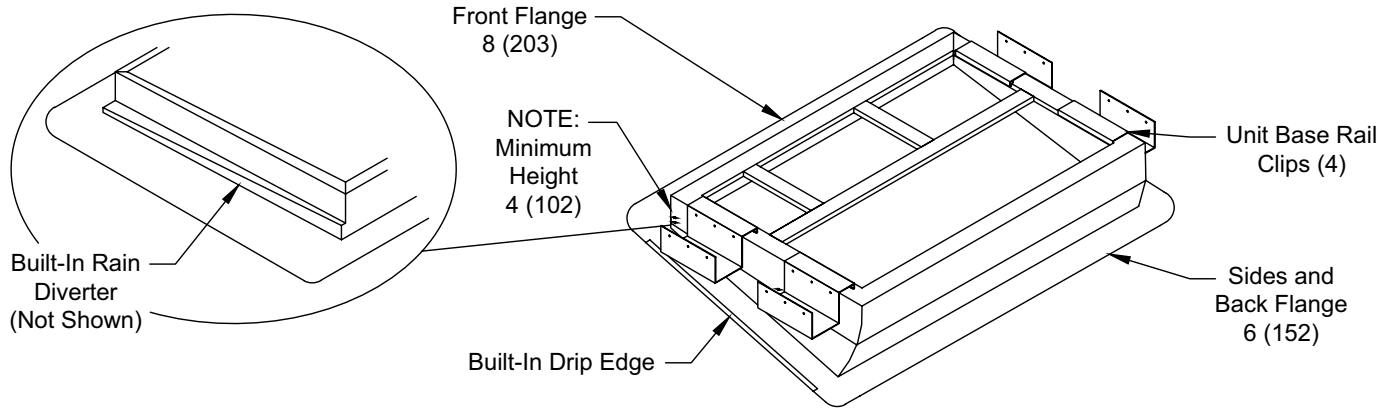

USAGE	A		B		C	
	IN.	MM	IN.	MM	IN.	MM
24,30,36	42-7/8	1089	13-7/8	352	16-7/8	429
42,48,60	51-3/8	1305	19-1/2	495	19-1/2	495



1-800-448-5872

All specifications and illustrations subject to change without notice and without incurring obligations.