

RPACE-713

PRODUCT SPECIFICATIONS

14 SEER/13.4 SEER2
ELECTRIC/ELECTRIC
PACKAGED UNIT

FORM NO. RPACE-713-100 (12/2025)

REFRIGERANT SYSTEM

- Environmentally friendly R454B refrigerant
- Copper tubing with enhanced fin coils
- Internal service gauge ports
- Sleeved distributor tubes
- Antimicrobial insulated drain pan
- High and Low Threaded pressure switches for system protection

CABINET CONSTRUCTION

- Heavy-gauge galvanized steel base rails with rigging holes
- Rounded corners for safety and an attractive, clean appearance
- One piece base design for strength and stability
- Condensate and coil runoff drains to the perimeter of the unit
- Horizontal and downflow duct openings are flanged to minimize water entry
- Low profile, with compact footprint
- Insulation to minimize heat loss plus reduce sound
- Textured pre-painted steel cabinet finish
- Superior service access to components
- Louvered coil guard protection
- One piece “no leak” top design

BLOWER

- Insulated compartment to reduce sound
- Efficient constant torque motor for wide airflow range
- Slide out blower housing for easy service

INSTALLATION

- Horizontal or down discharge capable
- Horizontal and downflow duct covers provided with unit for installation flexibility
- Drain pan float switch monitors condensate level in drain pan and shuts down unit if drain becomes clogged
- Utility connections on “right side”
- Kits enable bottom gas and power entry through base pan
- Seismic Certification (with Seismic Strapping Kit applied): Latest Edition of International Building Code, California Building Code, and ASCE 7-16

ACCESSORIES

- Clip roof curbs and adjustable pitch roof curbs available
- Internal filter kits
- Electric strip heat with optional single point power entry (side entry only)
- Duct adapters
- Closure kit for base rail openings



WARRANTY

10 year limited parts and compressor warranty. See limited warranty document for details.

MODEL NUMBER GUIDE

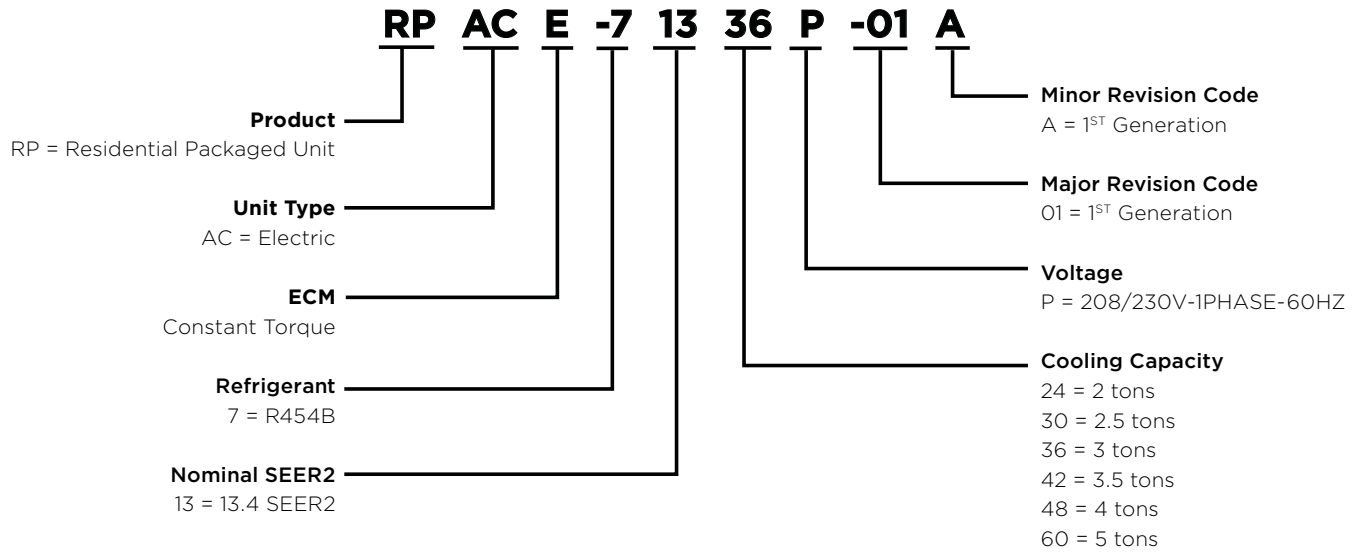

ELECTRICAL AND PHYSICAL DATA

Model	Voltage	Phase	Hz	Min Volts @ 60 Hz	MCA	Max Fuse/HACR Breaker	Compressor		Blower Motor		Condenser Motor		Refrig. Charge (oz.)	Weight (lbs.)
							RLA	FLA	HP	FLA	HP			
RPACE-71324	208-230	1	60	195	14.8	20.0	8.8	2.8	1/3	1.0	1/6	70 oz	367	
RPACE-71330					17.5	25.0	11.1	2.6	1/2	1.0	1/6	73 oz	379	
RPACE-71336					22.9	35.0	14.3	4.1	1/2	1.0	1/6	72 oz	387	
RPACE-71342					26.5	40.0	16.7	3.9	3/4	1.7	1/4	86 oz	460	
RPACE-71348					28.7	45.0	18.0	4.5	3/4	1.7	1/4	85 oz	461	
RPACE-71360					39.7	60.0	24.3	7.6	1	1.7	1/4	125 oz	503	

PERFORMANCE

Model	Cooling				Sound dBA
	Rated AHRI Capacity Btuh (SEER / SEER2)	Efficiency		Rated Sensible Capacity Btuh	
		SEER / EER	SEER2 / EER2		
RPACE-71324	22,600 / 22,600	14.0 / 11.0	13.4 / 10.6	17,400 / 16,900	77
RPACE-71330	28,400 / 28,400			21,900 / 21,800	79
RPACE-71336	34,000 / 33,400			26,100 / 25,700	78
RPACE-71342	40,000 / 40,000			30,800 / 30,800	78
RPACE-71348	45,500 / 44,500			35,000 / 34,200	77
RPACE-71360	57,000 / 57,500			41,600 / 41,900	78

*Certified in accordance with Unitary Air Conditioner Certification Program, which is based on AHRI Standard 210/240

BLOWER PERFORMANCE

Model	Blower Tap	CFM @ ext. Static Pressure in in. wc without filter, dry coil									
		0.1	0.2	0.3	0.4	0.5	0.6	0.7	0.8	0.9	1.0
RSPACE-71324	TAP 1	610	560	525	485	430	0	0	0	0	0
	TAP 2	820	795	760	720	690	650	615	575	540	470
	TAP 3	960	925	885	850	815	780	745	710	675	635
RSPACE-71330	TAP 1	850	820	780	745	710	680	630	590	550	515
	TAP 2	1040	1000	970	935	900	875	845	815	770	735
	TAP 3	1140	1105	1075	1045	1015	1000	965	925	890	825
RSPACE-71336	TAP 1	850	800	750	700	645	600	550	480	435	0
	TAP 2	1245	1210	1175	1140	1100	1065	1025	975	920	845
	TAP 3	1390	1355	1320	1285	1250	1205	1165	1125	1050	875
RSPACE-71342	TAP 1	800	720	640	550	475	390	310	0	0	0
	TAP 2	1470	1410	1360	1300	1260	1210	1155	1095	1000	940
	TAP 3	1600	1555	1510	1470	1430	1390	1340	1265	1210	1155
RSPACE-71348	TAP 1	1145	1075	1000	930	850	790	740	670	570	490
	TAP 2	1675	1630	1600	1540	1490	1440	1390	1300	1230	1125
	TAP 3	1775	1735	1700	1660	1605	1555	1515	1455	N/A	N/A
RSPACE-71360	TAP 1	1045	970	895	820	745	665	580	480	N/A	N/A
	TAP 2	1855	1810	1770	1725	1680	1630	1595	1550	N/A	N/A
	TAP 3	1965	1920	1875	1835	1785	1750	1710	1665	1615	1570

COOLING PERFORMANCE - EXTENDED RATINGS

Outdoor Model	Enter-ing Wet Bulb Temperature	Outdoor Temperature - DB °F																									
		85° F (29.4° C)						95° F (35° C)						105° F (40.6° C)						115° F (46.1° C)							
		Total Cooling Capacity		Com-pressor Motor Watts Input	Sensible To Total Ratio (S/T)			Total Cooling Capacity		Com-pressor Motor Watts Input	Sensible To Total Ratio (S/T)			Total Cooling Capacity		Com-pressor Motor Watts Input	Sensible To Total Ratio (S/T)			Total Cooling Capacity		Com-pressor Motor Watts Input	Sensible To Total Ratio (S/T)				
		cfm	L/s		kBTuh	kW	Dry Bulb				kBTuh	kW	Dry Bulb				kBTuh	kW	Dry Bulb				kBTuh	kW	Dry Bulb		
				75°F 23.9°C			80°F 26.7°C	85°F 29.4°C	75°F 23.9°C	80°F 26.7°C			85°F 29.4°C	75°F 23.9°C	80°F 26.7°C	85°F 29.4°C			75°F 23.9°C	80°F 26.7°C	85°F 29.4°C						
RPACE-71324	59°F (15°C)	650	305	21.4	6.3	1350	.89	1.00	1.00	20.6	6.0	1520	.91	1.00	1.00	19.8	5.8	1710	.93	1.00	1.00	18.9	5.5	1930	.96	1.00	1.00
		830	390	23.2	6.8	1350	.96	1.00	1.00	22.2	6.5	1520	.98	1.00	1.00	21.4	6.3	1720	1.00	1.00	1.00	20.2	5.9	1940	1.00	1.00	1.00
		1000	470	24.4	7.2	1340	1.00	1.00	1.00	23.4	6.9	1520	1.00	1.00	1.00	22.2	6.5	1720	1.00	1.00	1.00	21.2	6.2	1940	1.00	1.00	1.00
	63°F (17.2°C)	650	305	22.4	6.6	1350	.74	.86	.98	21.4	6.3	1520	.76	.88	1.00	20.4	6.0	1710	.77	.90	1.00	19.3	5.7	1930	.79	.92	1.00
		830	390	23.6	6.9	1340	.79	.93	1.00	22.6	6.6	1520	.80	.95	1.00	21.4	6.3	1720	.82	.97	1.00	20.2	5.9	1940	.84	1.00	1.00
		1000	470	24.6	7.2	1340	.83	.99	1.00	23.4	6.9	1520	.85	1.00	1.00	22.4	6.6	1720	.87	1.00	1.00	21.2	6.2	1940	.90	1.00	1.00
	67°F (19.4°C)	650	305	23.8	7.0	1340	.60	.72	.84	22.8	6.7	1520	.61	.73	.85	21.6	6.3	1720	.62	.75	.87	20.4	6.0	1940	.63	.77	.90
		830	390	25.0	7.3	1340	.63	.77	.90	24.0	7.0	1520	.64	.78	.92	22.6	6.6	1720	.66	.81	.95	21.4	6.3	1950	.67	.83	.98
		1000	470	26.0	7.6	1330	.66	.81	.96	24.6	7.2	1520	.68	.83	.98	23.2	6.8	1720	.69	.85	1.00	22.0	6.4	1950	.71	.88	1.00
	71°F (21.7°C)	650	305	25.0	7.3	1340	.46	.59	.70	23.8	7.0	1520	.47	.59	.72	22.6	6.6	1720	.47	.61	.73	21.4	6.3	1950	.49	.62	.75
		830	390	26.4	7.7	1330	.48	.62	.75	25.2	7.4	1520	.49	.63	.76	23.8	7.0	1720	.49	.65	.79	22.4	6.6	1950	.50	.67	.81
		1000	470	27.4	8.0	1320	.50	.65	.79	26.0	7.6	1510	.51	.67	.81	24.6	7.2	1720	.51	.68	.84	23.2	6.8	1960	.52	.70	.86
RPACE-71330	59°F (15°C)	800	380	27.4	8.0	1650	.94	1.00	1.00	26.4	7.7	1870	.97	1.00	1.00	25.2	7.4	2100	.99	1.00	1.00	23.8	7.0	2370	1.00	1.00	1.00
		1000	470	29.2	8.6	1660	1.00	1.00	1.00	28.0	8.2	1880	1.00	1.00	1.00	27.0	7.9	2120	1.00	1.00	1.00	25.4	7.4	2400	1.00	1.00	1.00
		1200	565	30.6	9.0	1660	1.00	1.00	1.00	29.4	8.6	1880	1.00	1.00	1.00	28.0	8.2	2130	1.00	1.00	1.00	26.6	7.8	2410	1.00	1.00	1.00
	63°F (17.2°C)	800	380	28.4	8.3	1660	.78	.91	1.00	27.2	8.0	1870	.80	.93	1.00	25.6	7.5	2110	.81	.96	1.00	24.2	7.1	2370	.84	.99	1.00
		1000	470	29.6	8.7	1660	.84	.99	1.00	28.2	8.3	1880	.86	1.00	1.00	27.0	7.9	2120	.88	1.00	1.00	25.4	7.4	2400	.91	1.00	1.00
		1200	565	30.6	9.0	1660	.90	1.00	1.00	29.4	8.6	1880	.92	1.00	1.00	28.0	8.2	2130	.95	1.00	1.00	26.6	7.8	2410	.98	1.00	1.00
	67°F (19.4°C)	800	380	30.0	8.8	1660	.63	.76	.88	28.6	8.4	1880	.64	.78	.91	27.2	8.0	2130	.65	.80	.93	25.6	7.5	2400	.67	.82	.96
		1000	470	31.4	9.2	1660	.67	.82	.96	29.8	8.7	1890	.68	.84	.99	28.2	8.3	2140	.69	.86	1.00	26.6	7.8	2410	.72	.90	1.00
		1200	565	32.2	9.4	1660	.71	.88	1.00	30.6	9.0	1890	.73	.90	1.00	29.0	8.5	2150	.74	.93	1.00	27.4	8.0	2430	.76	.96	1.00
	71°F (21.7°C)	800	380	31.6	9.3	1660	.49	.62	.74	30.2	8.9	1890	.50	.63	.76	28.8	8.4	2140	.50	.64	.78	27.2	8.0	2420	.51	.66	.80
		1000	470	33.0	9.7	1660	.52	.66	.80	31.4	9.2	1890	.51	.68	.82	29.8	8.7	2150	.53	.69	.85	28.2	8.3	2440	.54	.71	.88
		1200	565	34.0	10.0	1660	.53	.70	.86	32.4	9.5	1890	.54	.72	.88	30.6	9.0	2160	.55	.74	.91	28.8	8.4	2440	.57	.77	.95

COOLING PERFORMANCE - EXTENDED RATINGS

Outdoor Model	Enter-ing Wet Bulb Temperature	Total Air Volume		Outdoor Temperature - DB °F																							
				85° F (29.4° C)						95° F (35° C)						105° F (40.6° C)						115° F (46.1° C)					
				Total Cooling Capacity		Com-pressor Motor Watts Input	Sensible To Total Ratio (S/T)			Total Cooling Capacity		Com-pressor Motor Watts Input	Sensible To Total Ratio (S/T)			Total Cooling Capacity		Com-pressor Motor Watts Input	Sensible To Total Ratio (S/T)			Total Cooling Capacity		Com-pressor Motor Watts Input	Sensible To Total Ratio (S/T)		
		cfm	L/s	kBtuh	kW		Dry Bulb			kBtuh	kW		Dry Bulb			kBtuh	kW		Dry Bulb			kBtuh	kW		Dry Bulb		
						75°F 23.9°C	80°F 26.7°C	85°F 29.4°C	75°F 23.9°C			80°F 26.7°C	85°F 29.4°C	75°F 23.9°C	80°F 26.7°C			85°F 29.4°C	75°F 23.9°C	80°F 26.7°C	85°F 29.4°C						
RPACE-71336	59°F (15°C)	1000	470	32.4	9.5	2010	.94	1.00	1.00	31.4	9.2	2270	.96	1.00	1.00	30.0	8.8	2570	.98	1.00	1.00	28.6	8.4	2910	1.00	1.00	1.00
		1200	565	34.2	10.0	2010	1.00	1.00	1.00	33.0	9.7	2280	1.00	1.00	1.00	31.8	9.3	2580	1.00	1.00	1.00	30.2	8.9	2920	1.00	1.00	1.00
		1440	680	35.8	10.5	2020	1.00	1.00	1.00	34.6	10.1	2290	1.00	1.00	1.00	33.0	9.7	2580	1.00	1.00	1.00	31.6	9.3	2930	1.00	1.00	1.00
	63°F (17.2°C)	1000	470	33.8	9.9	2010	.78	.91	1.00	32.2	9.4	2280	.79	.93	1.00	30.8	9.0	2570	.81	.96	1.00	29.4	8.6	2920	.83	.98	1.00
		1200	565	34.8	10.2	2020	.83	.97	1.00	33.6	9.8	2280	.84	.99	1.00	32.0	9.4	2580	.86	1.00	1.00	30.2	8.9	2920	.89	1.00	1.00
		1440	680	36.0	10.6	2020	.88	1.00	1.00	34.6	10.1	2290	.90	1.00	1.00	33.0	9.7	2580	.92	1.00	1.00	31.6	9.3	2930	.95	1.00	1.00
	67°F (19.4°C)	1000	470	35.6	10.4	2020	.63	.76	.88	34.0	10.0	2280	.64	.78	.90	32.6	9.6	2580	.65	.79	.93	30.8	9.0	2920	.66	.81	.96
		1200	565	36.8	10.8	2020	.66	.80	.95	35.2	10.3	2290	.67	.82	.97	33.6	9.8	2590	.69	.84	.99	31.8	9.3	2930	.70	.87	1.00
		1440	680	37.8	11.1	2020	.70	.86	1.00	36.2	10.6	2290	.71	.88	1.00	34.4	10.1	2590	.73	.91	1.00	32.4	9.5	2930	.75	.94	1.00
	71°F (21.7°C)	1000	470	37.4	11.0	2020	.49	.62	.74	36.0	10.6	2290	.49	.63	.75	34.2	10.0	2590	.50	.64	.77	32.6	9.6	2930	.51	.66	.79
		1200	565	38.5	11.3	2030	.51	.65	.79	37.0	10.8	2300	.51	.66	.81	35.4	10.4	2600	.52	.68	.83	33.4	9.8	2940	.53	.70	.85
		1440	680	39.5	11.6	2030	.53	.69	.84	38.0	11.1	2300	.53	.71	.86	36.2	10.6	2600	.55	.73	.89	34.4	10.1	2940	.57	.75	.92
RPACE-71342	59°F (15°C)	1200	565	41.0	12.0	2490	.95	1.00	1.00	39.5	11.6	2810	.96	1.00	1.00	37.8	11.1	3160	.98	1.00	1.00	36.4	10.7	3560	1.00	1.00	1.00
		1450	685	43.5	12.7	2480	1.00	1.00	1.00	42.0	12.3	2800	1.00	1.00	1.00	40.0	11.7	3150	1.00	1.00	1.00	38.5	11.3	3560	1.00	1.00	1.00
		1750	825	45.5	13.3	2470	1.00	1.00	1.00	44.0	12.9	2790	1.00	1.00	1.00	42.0	12.3	3150	1.00	1.00	1.00	40.0	11.7	3560	1.00	1.00	1.00
	63°F (17.2°C)	1200	565	42.5	12.5	2490	.78	.92	1.00	40.5	11.9	2800	.79	.94	1.00	38.5	11.3	3160	.81	.96	1.00	36.8	10.8	3560	.83	.98	1.00
		1450	685	44.0	12.9	2480	.83	.98	1.00	42.5	12.5	2800	.84	.99	1.00	40.0	11.7	3150	.87	1.00	1.00	38.5	11.3	3560	.89	1.00	1.00
		1750	825	46.0	13.5	2470	.89	1.00	1.00	44.0	12.9	2790	.91	1.00	1.00	42.0	12.3	3150	.93	1.00	1.00	40.5	11.9	3560	.96	1.00	1.00
	67°F (19.4°C)	1200	565	44.5	13.0	2470	.63	.76	.89	43.0	12.6	2790	.64	.78	.91	41.0	12.0	3150	.65	.79	.93	39.0	11.4	3560	.65	.81	.96
		1450	685	46.5	13.6	2460	.66	.81	.95	44.5	13.0	2790	.68	.83	.97	42.5	12.5	3150	.68	.85	.99	40.0	11.7	3560	.71	.87	1.00
		1750	825	48.0	14.1	2450	.70	.87	1.00	45.5	13.3	2780	.72	.89	1.00	43.5	12.7	3140	.72	.92	1.00	41.5	12.2	3560	.74	.94	1.00
	71°F (21.7°C)	1200	565	47.0	13.8	2460	.48	.62	.74	45.0	13.2	2780	.49	.63	.76	43.5	12.7	3140	.50	.64	.77	41.0	12.0	3560	.51	.66	.79
		1450	685	49.0	14.4	2440	.50	.65	.80	47.0	13.8	2770	.51	.67	.82	44.5	13.0	3140	.52	.68	.83	42.5	12.5	3560	.53	.69	.86
		1750	825	50.5	14.8	2430	.53	.70	.86	48.0	14.1	2760	.53	.71	.88	46.0	13.5	3130	.55	.73	.90	43.5	12.7	3550	.56	.75	.94

COOLING PERFORMANCE - EXTENDED RATINGS

Outdoor Model	Enter-ing Wet Bulb Temperature	Outdoor Temperature - DB °F																									
		Total Air Volume		85° F (29.4° C)						95° F (35° C)						105° F (40.6° C)						115° F (46.1° C)					
				Total Cooling Capacity		Com-pressor Motor Watts Input	Sensible To Total Ratio (S/T)			Total Cooling Capacity		Com-pressor Motor Watts Input	Sensible To Total Ratio (S/T)			Total Cooling Capacity		Com-pressor Motor Watts Input	Sensible To Total Ratio (S/T)			Total Cooling Capacity		Com-pressor Motor Watts Input	Sensible To Total Ratio (S/T)		
		cfm	L/s	kBTuh	kW		Dry Bulb			kBTuh	kW		Dry Bulb			kBTuh	kW		Dry Bulb			kBTuh	kW		Dry Bulb		
						75°F 23.9°C	80°F 26.7°C	85°F 29.4°C	75°F 23.9°C			80°F 26.7°C	85°F 29.4°C	75°F 23.9°C	80°F 26.7°C			85°F 29.4°C	75°F 23.9°C	80°F 26.7°C	85°F 29.4°C						
RPACE-71348	59°F (15°C)	1300	615	43.5	12.7	2590	.94	1.00	1.00	42.0	12.3	2960	.96	1.00	1.00	40.5	11.9	3370	.98	1.00	1.00	38.5	11.3	3840	1.00	1.00	1.00
		1600	755	46.0	13.5	2600	1.00	1.00	1.00	44.5	13.0	2970	1.00	1.00	1.00	42.5	12.5	3390	1.00	1.00	1.00	40.5	11.9	3850	1.00	1.00	1.00
		1900	895	48.0	14.1	2620	1.00	1.00	1.00	46.5	13.6	2990	1.00	1.00	1.00	44.5	13.0	3400	1.00	1.00	1.00	42.5	12.5	3860	1.00	1.00	1.00
	63°F (17.2°C)	1300	615	45.0	13.2	2600	.77	.91	1.00	43.5	12.7	2970	.79	.92	1.00	41.0	12.0	3380	.80	.95	1.00	39.0	11.4	3850	.83	.98	1.00
		1600	755	47.0	13.8	2610	.83	.98	1.00	45.0	13.2	2980	.84	1.00	1.00	43.0	12.6	3390	.86	1.00	1.00	41.0	12.0	3860	.89	1.00	1.00
		1900	895	48.0	14.1	2620	.88	1.00	1.00	46.5	13.6	2990	.90	1.00	1.00	45.0	13.2	3400	.92	1.00	1.00	42.5	12.5	3860	.95	1.00	1.00
	67°F (19.4°C)	1300	615	47.5	13.9	2610	.63	.75	.88	45.5	13.3	2980	.63	.77	.90	43.5	12.7	3390	.64	.79	.92	41.0	12.0	3860	.66	.81	.95
		1600	755	49.5	14.5	2620	.66	.81	.95	47.5	13.9	2990	.67	.83	.97	45.0	13.2	3400	.69	.85	1.00	43.0	12.6	3860	.70	.87	1.00
		1900	895	51.0	14.9	2630	.70	.86	1.00	49.0	14.4	3000	.71	.88	1.00	46.5	13.6	3400	.72	.91	1.00	44.0	12.9	3870	.75	.93	1.00
	71°F (21.7°C)	1300	615	50.0	14.7	2620	.48	.61	.73	48.0	14.1	2990	.49	.62	.75	46.0	13.5	3400	.49	.63	.77	43.5	12.7	3860	.50	.65	.79
		1600	755	52.0	15.2	2630	.51	.65	.79	50.0	14.7	3000	.51	.66	.81	47.5	13.9	3410	.52	.68	.83	45.0	13.2	3870	.53	.70	.86
		1900	895	53.5	15.7	2630	.53	.69	.85	51.0	14.9	3000	.54	.70	.87	48.5	14.2	3410	.54	.72	.89	46.0	13.5	3870	.56	.74	.92
RPACE-71360	59°F (15°C)	1450	685	55.5	16.3	3470	.89	1.00	1.00	54.0	15.8	3920	.91	1.00	1.00	51.5	15.1	4430	.93	1.00	1.00	49.5	14.5	5020	.95	1.00	1.00
		1800	850	60.0	17.6	3490	.96	1.00	1.00	57.5	16.9	3950	.98	1.00	1.00	55.0	16.1	4460	1.00	1.00	1.00	53.0	15.5	5060	1.00	1.00	1.00
		2100	990	62.5	18.3	3500	1.00	1.00	1.00	60.0	17.6	3960	1.00	1.00	1.00	58.0	17.0	4480	1.00	1.00	1.00	55.0	16.1	5080	1.00	1.00	1.00
	63°F (17.2°C)	1450	685	58.5	17.1	3490	.74	.86	.98	56.5	16.6	3940	.76	.88	1.00	54.0	15.8	4440	.77	.90	1.00	51.0	14.9	5030	.79	.93	1.00
		1800	850	61.5	18.0	3500	.79	.93	1.00	58.5	17.1	3950	.81	.95	1.00	56.0	16.4	4470	.82	.98	1.00	53.5	15.7	5060	.85	1.00	1.00
		2100	990	63.5	18.6	3510	.83	.98	1.00	60.5	17.7	3960	.85	1.00	1.00	57.5	16.9	4480	.87	1.00	1.00	55.5	16.3	5080	.90	1.00	1.00
	67°F (19.4°C)	1450	685	61.5	18.0	3500	.60	.72	.83	59.5	17.4	3960	.61	.73	.85	56.5	16.6	4470	.62	.75	.87	53.5	15.7	5060	.63	.77	.89
		1800	850	65.0	19.0	3510	.64	.77	.90	61.5	18.0	3970	.65	.79	.92	59.5	17.4	4490	.66	.81	.95	56.0	16.4	5090	.67	.83	.98
		2100	990	66.5	19.5	3520	.67	.81	.96	64.0	18.8	3980	.68	.83	.99	60.5	17.7	4500	.69	.86	1.00	57.5	16.9	5100	.71	.88	1.00
	71°F (21.7°C)	1450	685	65.0	19.0	3510	.47	.59	.70	62.5	18.3	3970	.48	.60	.71	59.5	17.4	4490	.48	.61	.73	56.5	16.6	5090	.49	.62	.75
		1800	850	67.5	19.8	3520	.49	.63	.75	65.5	19.2	3990	.50	.64	.77	62.0	18.2	4510	.50	.65	.79	59.0	17.3	5120	.52	.67	.81
		2100	990	69.5	20.4	3530	.51	.66	.80	67.0	19.6	4000	.52	.67	.82	63.5	18.6	4520	.53	.69	.84	60.5	17.7	5130	.54	.71	.86

ACCESSORY AIR RESISTANCE DATA - in. w.g.

Air Volume cfm	Rectangular to Round Duct Adaptor Kits					
	Downflow		Horizontal			
	14 in. Diameter		14 in. Diameter		16 in. Diameter	18 in. Diameter
	24, 30, 36	42, 48, 60	24, 30, 36	42, 48, 60	42, 48, 60	42, 48, 60
500	0.03	---	0.04	---	---	---
600	0.05	---	0.07	---	---	---
700	0.08	0.13	0.08	0.13	---	---
800	0.10	0.17	0.12	0.16	---	---
900	0.12	0.21	0.15	0.21	---	---
1000	0.17	0.24	0.19	0.25	0.11	0.03
1100	0.18	0.30	0.23	0.30	0.11	0.03
1200	0.20	0.36	0.29	0.37	0.13	0.03
1300	0.26	0.43	0.31	0.43	0.17	0.03
1400	0.31	0.50	0.39	0.51	0.20	0.03
1500	---	0.57	---	0.57	0.21	0.05
1600	---	0.63	---	0.65	0.26	0.05
1700	---	0.71	---	0.72	0.30	0.06
1800	---	0.80	---	0.81	0.30	0.06
1900	---	0.91	---	0.90	0.40	0.06
2000	---	0.99	---	1.01	0.41	0.06

HEAT STRIP ELECTRICAL

Model	Heater Size	Heater Model	Min BLW Speed	AMPS 240V	AMPS 208V	Input kw 240V	Input kw 208V	Circuit 1 240V			Circuit 1 208V			Circuit 2 240V			Circuit 2 208V			SINGLE CIRCUIT 240V		SINGLE CIRCUIT 208V	
								MCA	MAX FUSE	MCA	MAX FUSE	MCA	MAX FUSE	MCA	MAX FUSE	MCA	MAX FUSE	MCA	MAX FUSE	MCA	MAX FUSE	MCA	MAX FUSE
RSPACE-71324P	5KW	PHK05BP-1	Tap 4	20.8	18.1	5	3.8	29.5	30.0	26.1	30.0	0.0	-	0.0	-	0.0	-	29.5	30.0	26.1	30.0	29.5	30.0
	7.5KW	PHK07BP-1	Tap 4	31.3	27.1	7.5	5.6	42.6	45.0	37.4	40.0	0.0	-	0.0	-	0.0	-	42.6	45.0	37.4	40.0	42.6	45.0
	10 KW	PHK10BP-1	Tap 4	41.7	36.1	10	7.5	55.6	60.0	48.6	50.0	0.0	-	0.0	-	0.0	-	55.6	60.0	48.6	50.0	55.6	60.0
RSPACE-71330P	5KW	PHK05BP-1	Tap 4	20.8	18.1	5	3.8	29.3	30.0	25.8	30.0	0.0	-	0.0	-	0.0	-	29.3	30.0	25.8	30.0	29.3	30.0
	7.5KW	PHK07BP-1	Tap 4	31.3	27.1	7.5	5.6	42.3	45.0	37.1	40.0	0.0	-	0.0	-	0.0	-	42.3	45.0	37.1	40.0	42.3	45.0
	10 KW	PHK10BP-1	Tap 4	41.7	36.1	10	7.5	55.3	60.0	48.4	50.0	0.0	-	0.0	-	0.0	-	55.3	60.0	48.4	50.0	55.3	60.0
RSPACE-71336P	5KW	PHK05BP-1	Tap 4	20.8	18.1	5	3.8	31.2	35.0	27.7	30.0	0.0	-	0.0	-	0.0	-	31.2	35.0	27.7	30.0	31.2	35.0
	7.5KW	PHK07BP-1	Tap 4	31.3	27.1	7.5	5.6	44.2	45.0	39.0	40.0	0.0	-	0.0	-	0.0	-	44.2	45.0	39.0	40.0	44.2	45.0
	10 KW	PHK10BP-1	Tap 4	41.7	36.1	10	7.5	57.2	60.0	50.3	50.0	0.0	-	0.0	-	0.0	-	57.2	60.0	50.3	60.0	57.2	60.0
RSPACE-71342P	15 KW	PHK15CP-1	Tap 4	62.5	54.2	15	11.3	57.2	60.0	50.3	60.0	26.0	30.0	22.6	25.0	22.6	25.0	22.6	25.0	22.6	25.0	22.6	25.0
	5KW	PHK05BP-1	Tap 4	20.8	18.1	5	3.8	30.9	35.0	27.4	30.0	0.0	-	0.0	-	0.0	-	30.9	35.0	27.4	30.0	30.9	35.0
	7.5KW	PHK07BP-1	Tap 4	31.3	27.1	7.5	5.6	43.9	45.0	38.7	40.0	0.0	-	0.0	-	0.0	-	43.9	45.0	38.7	40.0	43.9	45.0
RSPACE-71348P	10 KW	PHK10BP-1	Tap 4	41.7	36.1	10	7.5	57.0	60.0	50.0	60.0	0.0	-	0.0	-	0.0	-	57.0	60.0	50.0	60.0	57.0	60.0
	15 KW	PHK15CP-1	Tap 4	62.5	54.2	15	11.3	57.0	60.0	50.0	60.0	26.0	30.0	22.6	25.0	22.6	25.0	22.6	25.0	22.6	25.0	22.6	25.0
	20 KW	PHK20CP-1	Tap 4	83.3	72.2	20	15	57.0	60.0	50.0	60.0	52.1	60.0	45.1	50.0	45.1	50.0	45.1	50.0	45.1	50.0	45.1	50.0
RSPACE-71360P	5KW	PHK05BP-1	Tap 4	20.8	18.1	5	3.8	31.7	35.0	28.2	30.0	0.0	-	0.0	-	0.0	-	31.7	35.0	28.2	30.0	31.7	35.0
	7.5KW	PHK07BP-1	Tap 4	31.3	27.1	7.5	5.6	44.7	45.0	39.5	40.0	0.0	-	0.0	-	0.0	-	44.7	45.0	39.5	40.0	44.7	45.0
	10 KW	PHK10BP-1	Tap 4	41.7	36.1	10	7.5	57.7	60.0	50.8	60.0	0.0	-	0.0	-	0.0	-	57.7	60.0	50.8	60.0	57.7	60.0
RSPACE-71360P	15 KW	PHK15CP-1	Tap 4	62.5	54.2	15	11.3	57.7	60.0	50.8	60.0	26.0	30.0	22.6	25.0	22.6	25.0	22.6	25.0	22.6	25.0	22.6	25.0
	20 KW	PHK20CP-1	Tap 4	83.3	72.2	20	15	57.7	60.0	50.8	60.0	52.1	60.0	45.1	50.0	45.1	50.0	45.1	50.0	45.1	50.0	45.1	50.0
	5KW	PHK05BP-1	Tap 4	20.8	18.1	5	3.8	35.5	40.0	32.1	35.0	0.0	-	0.0	-	0.0	-	35.5	40.0	32.1	35.0	35.5	40.0
RSPACE-71360P	7.5KW	PHK07BP-1	Tap 4	31.3	27.1	7.5	5.6	48.6	50.0	43.4	45.0	0.0	-	0.0	-	0.0	-	48.6	50.0	43.4	45.0	48.6	50.0
	10 KW	PHK10BP-1	Tap 4	41.7	36.1	10	7.5	61.6	70.0	54.6	60.0	0.0	-	0.0	-	0.0	-	61.6	70.0	54.6	60.0	61.6	70.0
	15 KW	PHK15CP-1	Tap 4	62.5	54.2	15	11.3	61.6	70.0	54.6	60.0	26.0	30.0	22.6	25.0	22.6	25.0	22.6	25.0	22.6	25.0	22.6	25.0
20 KW	PHK20CP-1	Tap 4	83.3	72.2	20	15	61.6	70.0	54.6	60.0	52.1	60.0	45.1	50.0	45.1	50.0	45.1	50.0	45.1	50.0	45.1	50.0	

DIMENSIONS (IN.) - SMALL BASE (24, 30, 36)

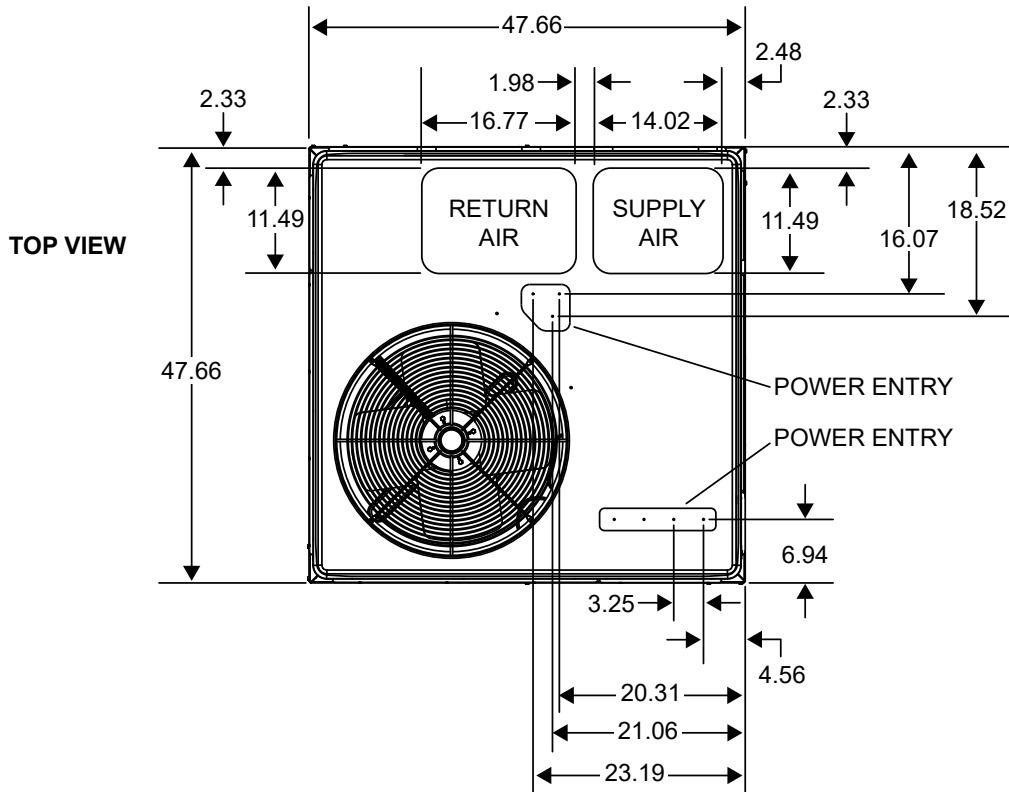

SIDE VIEWS

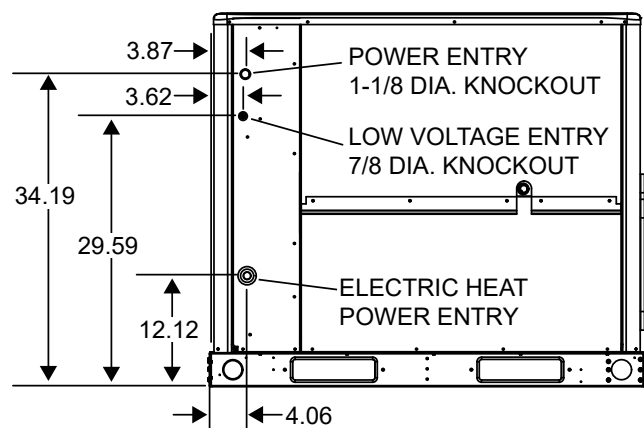
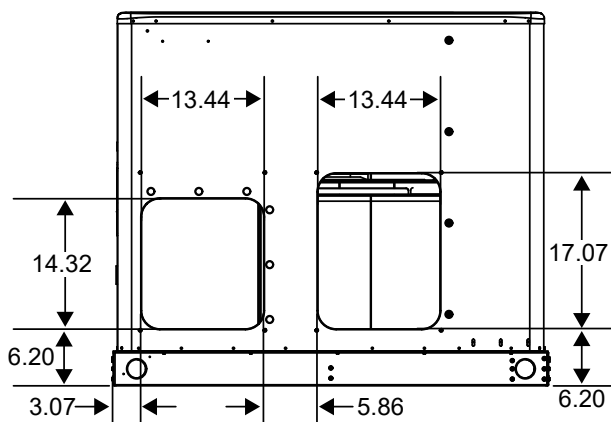
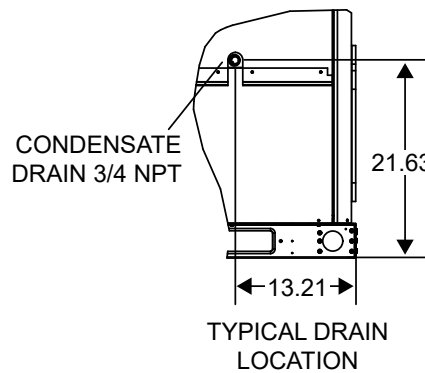
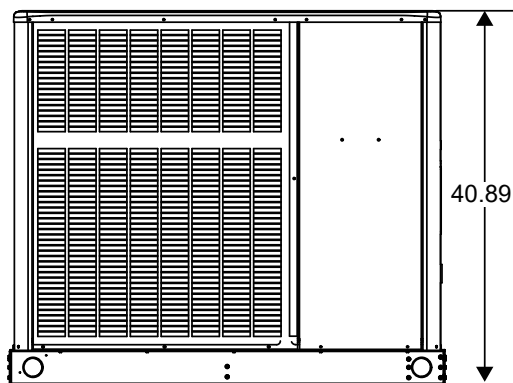

DIMENSIONS (IN.) - LARGE BASE (42, 48, 60)

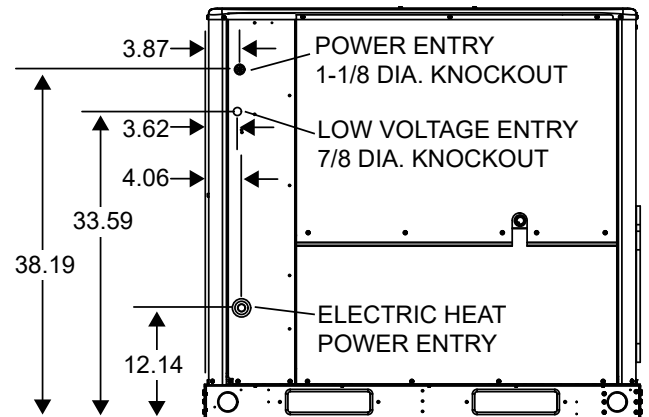
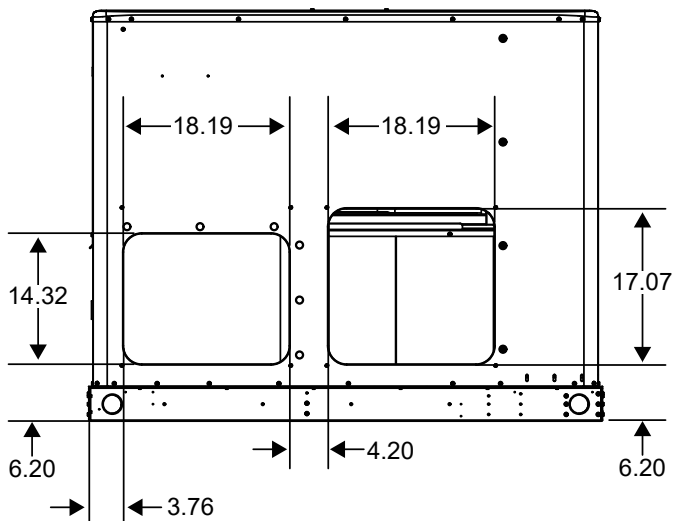
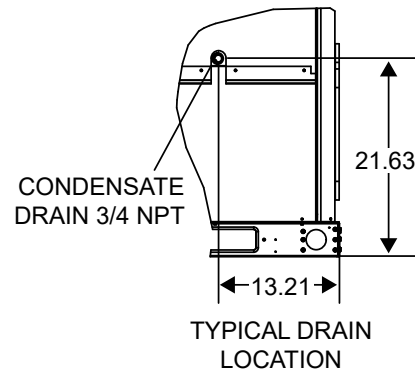
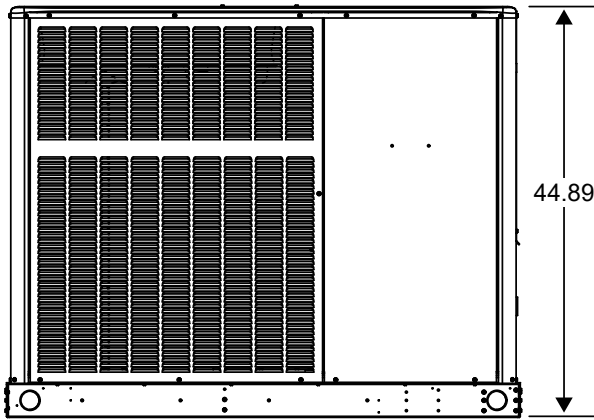
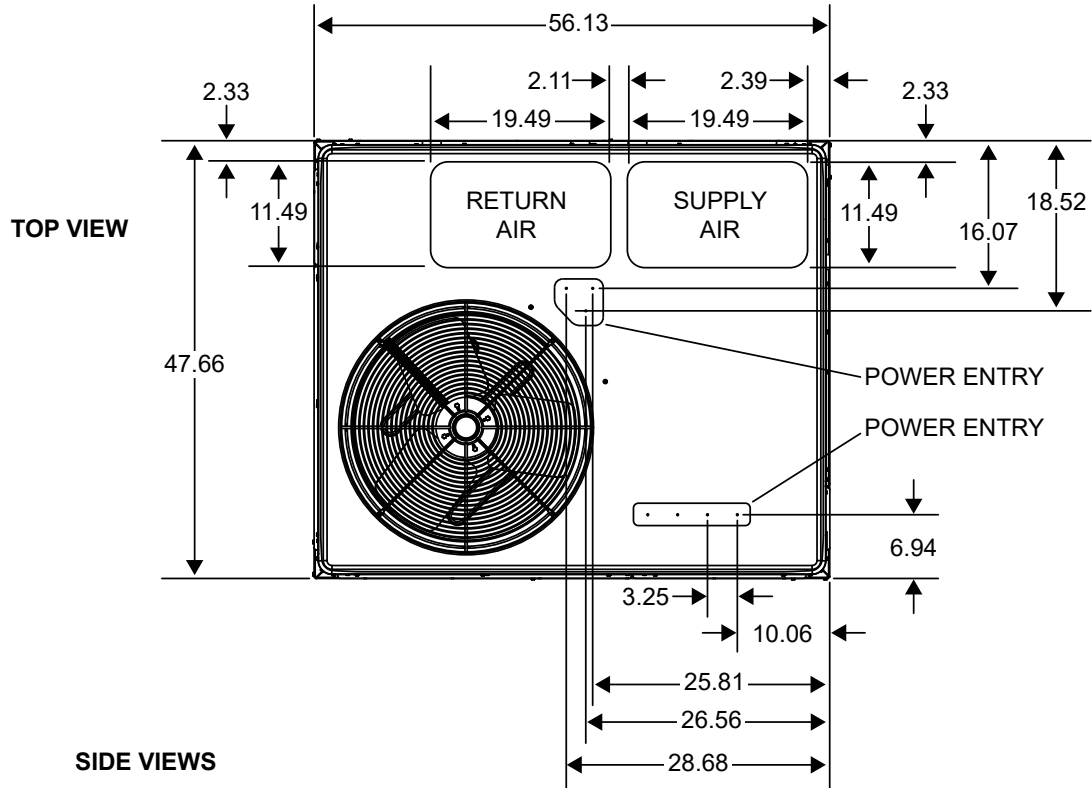

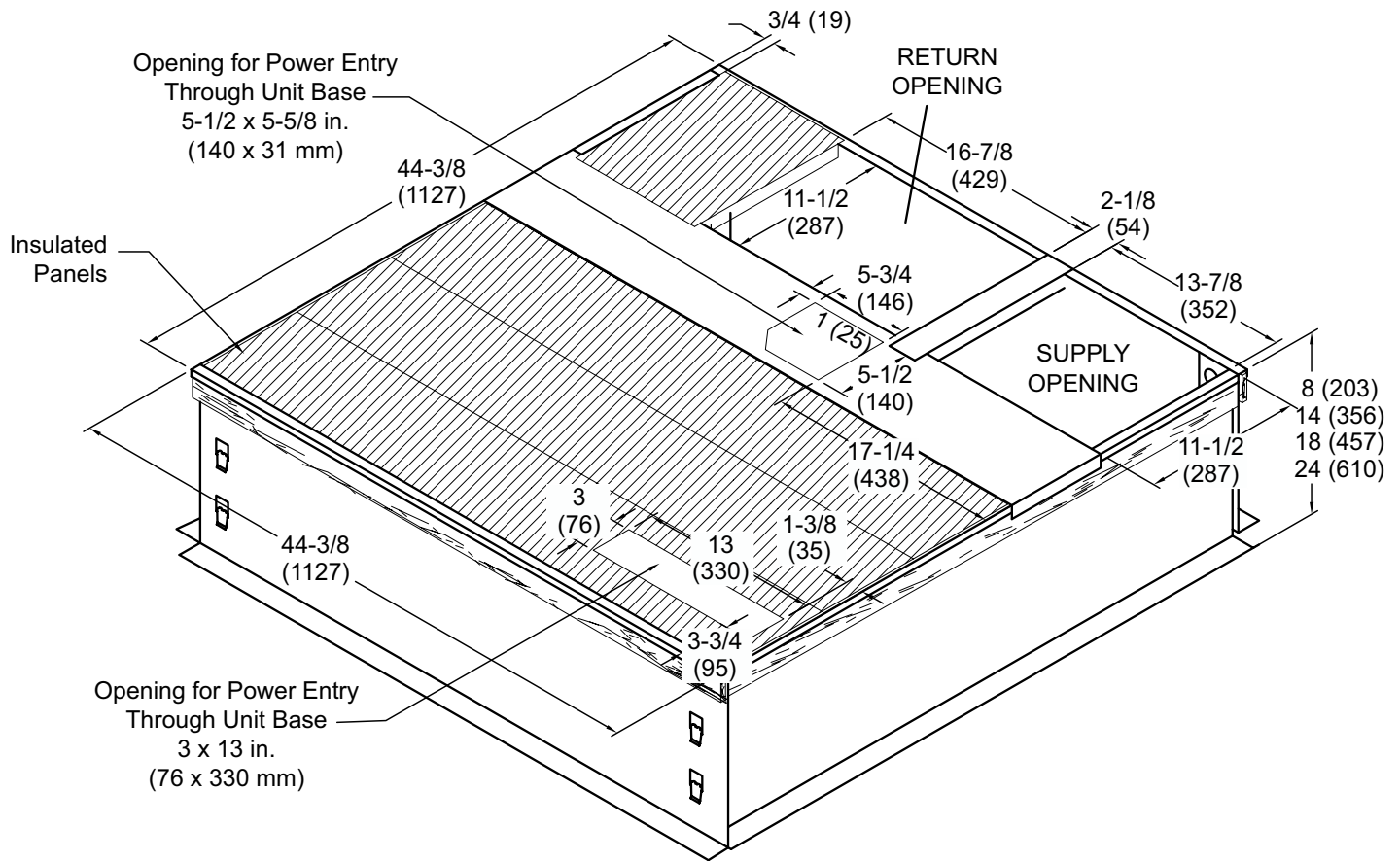
ROOF CURB DIMENSIONS - SMALL BASE (24, 30, 36)

NOTE - Roof deck may be omitted within confines of curb.

NOTE - All Curbs::

- IBC 2018 compliant
- CBC 2019 compliant
- Seismic rating - SDS 2.0g, z/h=1, Ip=1.5
- Wind rating - 240 mph (Lateral), 214 mph (Uplift)
- Maximum load rating - 800 lbs.
- Tool-less filter access panels NOT for seismic-rated applications

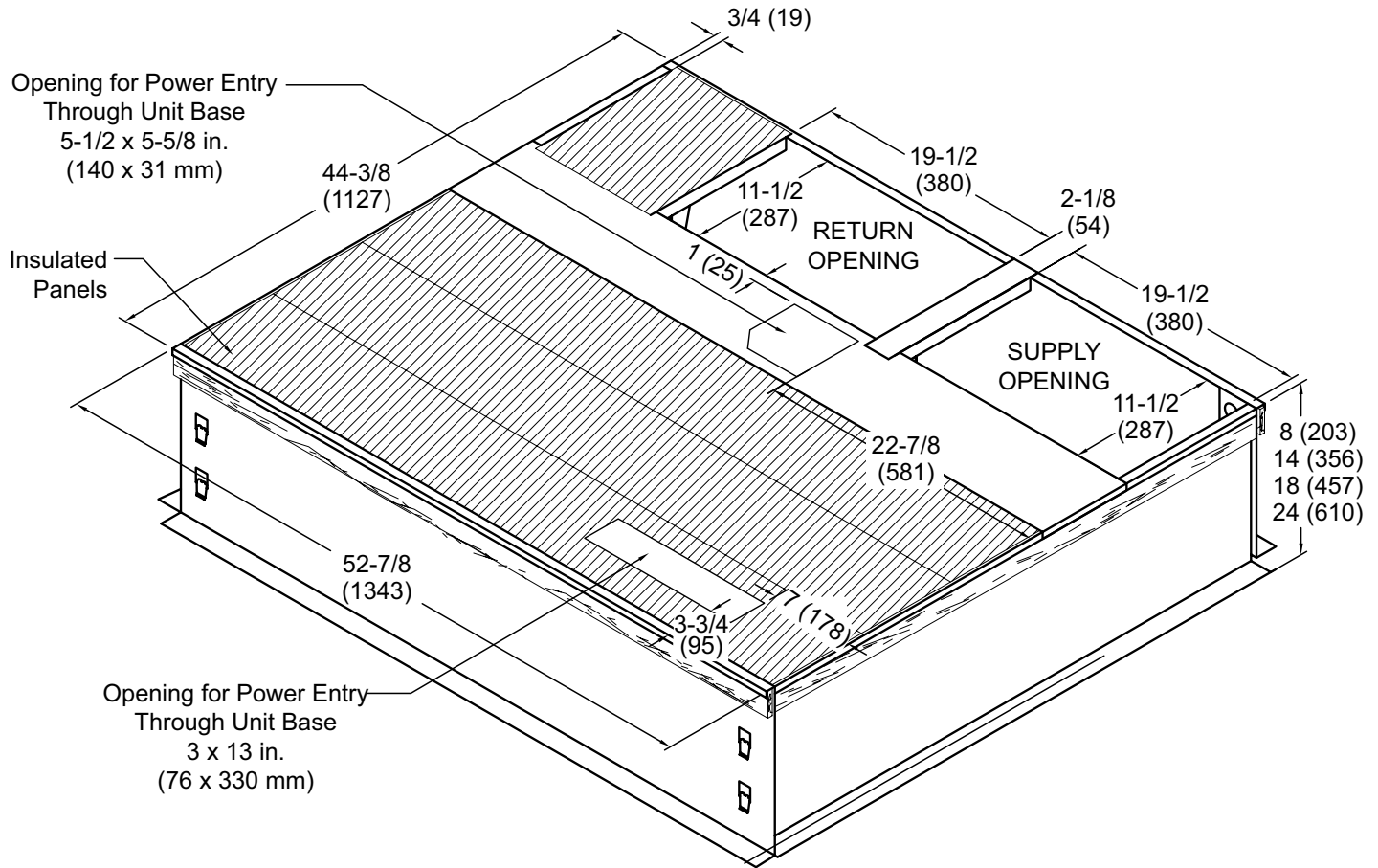
ROOF CURB DIMENSIONS - LARGE BASE (42, 48, 60)

NOTE - Roof deck may be omitted within confines of curb.

NOTE - All Curbs::

- IBC 2018 compliant
- CBC 2019 compliant
- Seismic rating - SDS 2.0g, z/h=1, Ip=1.5
- Wind rating - 240 mph (Lateral), 214 mph (Uplift)
- Maximum load rating - 800 lbs.
- Tool-less filter access panels NOT for seismic-rated applications

ADJUSTABLE CURB (KNOCK-DOWN STYLE) DIMENSIONS - SMALL BASE (24, 30, 36)

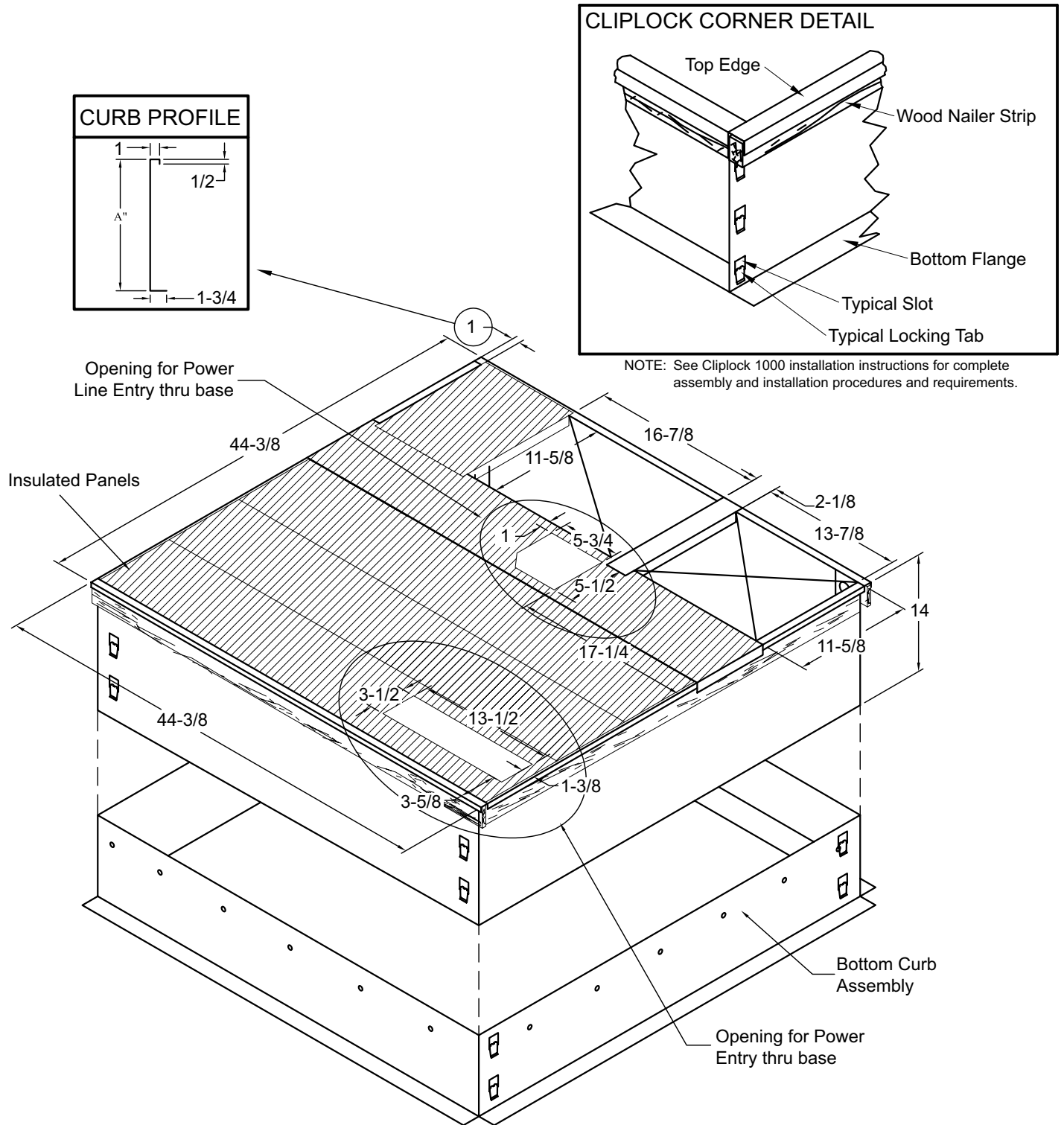

NOTE - Roof deck may be omitted within confines of curb.

NOTE - All Curbs::

- IBC 2018 compliant
- CBC 2019 compliant
- Seismic rating - SDS 2.0g, z/h=1, I_p=1.5
- Wind rating - 240 mph (Lateral), 214 mph (Uplift)
- Maximum load rating - 800 lbs.
- Tool-less filter access panels NOT for seismic-rated applications

ADJUSTABLE CURB (KNOCK-DOWN STYLE) DIMENSIONS - LARGE BASE (42, 48, 60)

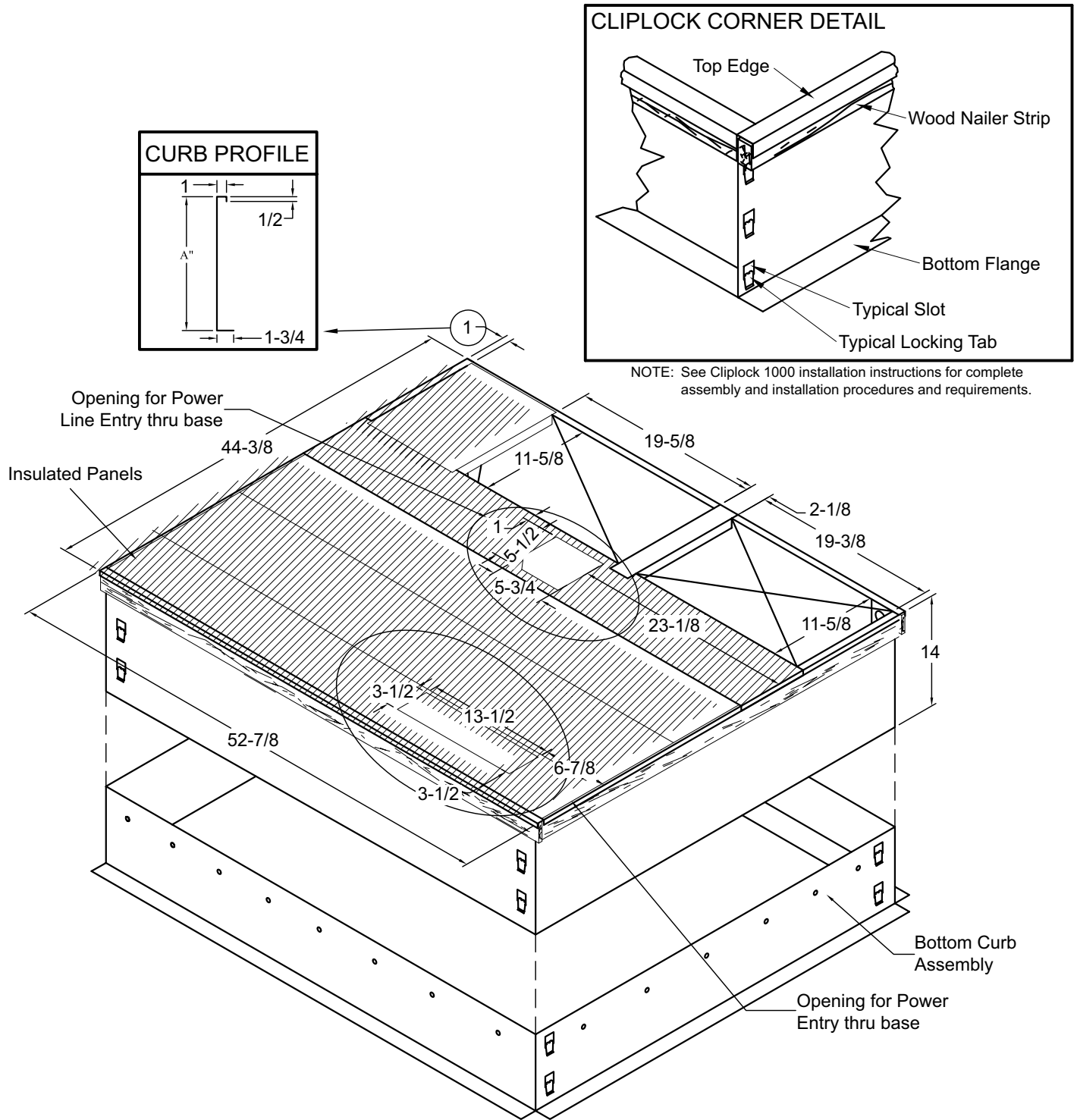

NOTE - Roof deck may be omitted within confines of curb.

NOTE - All Curbs::

- IBC 2018 compliant
- CBC 2019 compliant
- Seismic rating - SDS 2.0g, z/h=1, I_p=1.5
- Wind rating - 240 mph (Lateral), 214 mph (Uplift)
- Maximum load rating - 800 lbs.
- Tool-less filter access panels NOT for seismic-rated applications

ADJUSTABLE CURB (WELDED STYLE) DIMENSIONS

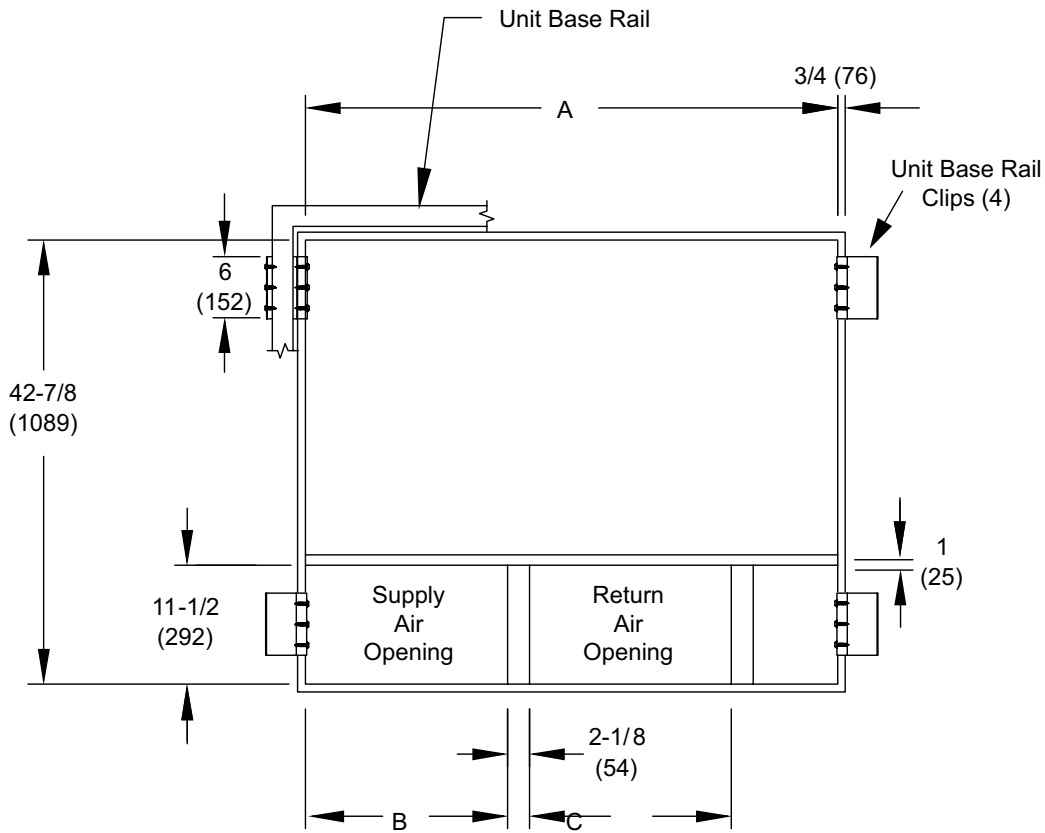
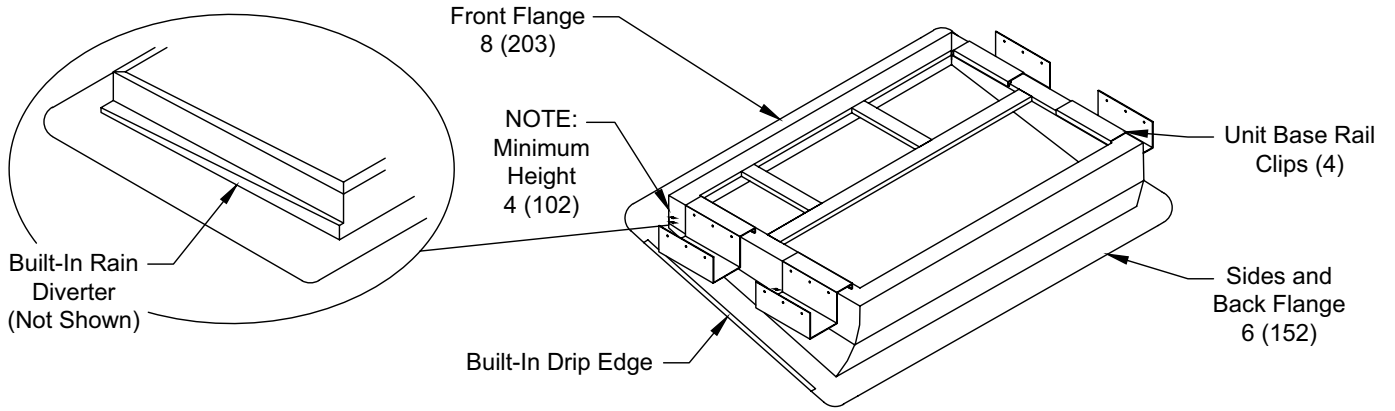

Usage	A		B		C	
	in.	mm	in.	mm	in.	mm
24,30,36	42-7/8	1089	13-7/8	352	16-7/8	429
42,48,60	51-3/8	1305	19-1/2	495	19-1/2	495

ACCESSORIES

Description	Where Used	Kit Number
Compressor Crankcase Heater	36, 42	27U17
	48, 60	27P79
Compressor Hard Start Kit	24, 30, 36	10J42
	42, 48, 60	88M91
Compressor Timed-Off Control	All	47J28
Low Ambient Kit	All	21D20
Electric Heater 5kW - PHK05BP	All	10W47
Electric Heater 7.5kW - PHK07BP	All	10W48
Electric Heater 10kW - PHK10BP	All	10W49
Electric Heater 15kW - PHK15CP	36, 42, 48, 60	10W50
Electric Heater 20kW - PHK20CP	42, 48, 60	10W51
Internal Filter Rack Kit	24, 30, 36	11U73
	42, 48, 60	11U74
8" Height Full Perimeter Curb	24, 30, 36	21J13
	42, 48, 60	21J17
14" Height Full Perimeter Curb	24, 30, 36	21J14
	42, 48, 60	21J19
18" Height Full Perimeter Curb	24, 30, 36	21J15
	42, 48, 60	21J20
24" Height Full Perimeter Curb	24, 30, 36	21J16
	42, 48, 60	21J25
Adjustable Pitch Roof Curb (Knock-Down Style)	24, 30, 36	21J26
	42, 48, 60	21U04
Adjustable Pitch Roof Curb (Welded Style)	24, 30, 36	22V54
	42, 48, 60	22V55
Strapping Kit - Hurricane	Slab	21J74
	Rail	22G53
Strapping Kit - Seismic	All	21J75
Duct Adapter Kit - Horizontal	14 in. dia.	21J92
	14 in. dia.	21D24
	16 in. dia.	22U78
	18 in. dia.	22U79
Duct Adapter Kit - Downflow	14 in. dia.	20X82
	14 in. dia.	21D26
Bottom Power Entry Kit	All	21J78
Base Rail Openings - Closure Kit	All	21J84
Single Point Power - 5kW ASPWR813-1	All	13W88
Single Point Power - 7.5 kW ASPWR814-1	All	13W89
Single Point Power - 10kW ASPWR815-1	All	13W90
Single Point Power - 15-20kW ASPWR816-1	36, 42, 48, 60	13W91



1-800-448-5872

All specifications and illustrations subject to change without notice and without incurring obligations.