

INSTALLATION INSTRUCTIONS

7ECX

R410A Upflow Indoor Coils

This manual must be left with the homeowner for future reference.

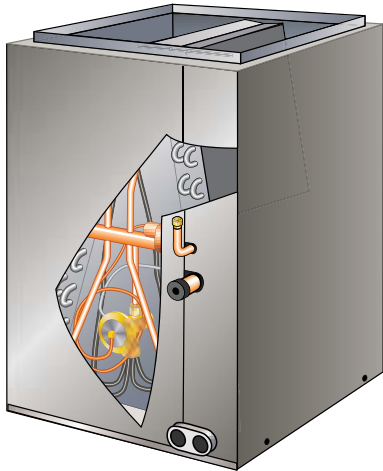

⚠ IMPORTANT

If installing in an R454B application, R454B coil sensor kit (26Z69), Refrigerant Detection System Control (27A05 or 27A06)* and R454B TXV (26Z70, 26Z71, or 26Z72) must be ordered.

If installing in an R454B application, use installation instructions provided in R454B coil conversion kit (26Z69).

For sensor maintenance recommendations refer to the instructions in kit 26Z69.

*For non-communicating furnaces, order kit 27A05. For communicating furnaces, order kit 27A06.

⚠ WARNING

Improper installation, adjustment, alteration, service or maintenance can cause personal injury, loss of life, or damage to property.

Installation and service must be performed by a licensed professional installer (or equivalent) or a service agency.

⚠ IMPORTANT

The Clean Air Act of 1990 bans the intentional venting of refrigerant (CFCs, HCFCs and HFCs) as of July 1, 1992. Approved methods of recovery, recycling or reclaiming must be followed. Fines and/or incarceration may be levied for noncompliance.

⚠ CAUTION

As with any mechanical equipment, contact with sharp sheet metal edges can result in personal injury. Take care while handling this equipment and wear gloves and protective clothing.

⚠ WARNING

Every working procedure that affects safety means shall only be carried out by competent persons. This appliance is not to be used by persons (including children) with reduced physical, sensory or mental capabilities, or lack of experience and knowledge, unless they have been given supervision or instruction concerning use of the appliance by a person responsible for their safety. Children should be supervised to ensure they do not play with the appliance.

⚠ WARNING

Maximum altitude of application is 3200m above sea level.

Allied Air Enterprises, LLC
215 Metropolitan Drive
West Columbia, SC 29170



(P) 508452-01

Model Number Identification

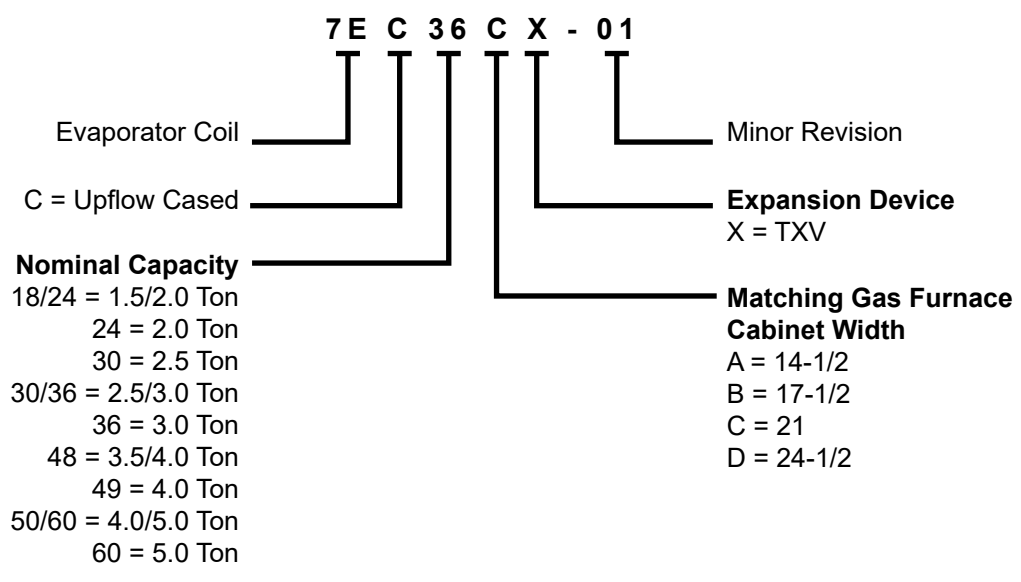

NOTE: This unit is a **PARTIAL UNIT AIR CONDITIONER**, complying with **PARTIAL UNIT** requirements of this Standard, and must only be connected to other units that have been confirmed as complying to corresponding **PARTIAL UNIT** requirements of this Standard, UL 60335-2-40/CSA C22.2 No. 60335-2-40, or UL 1995/CSA C22.2 No 236.

NOTE: **PARTIAL UNITS** shall only be connected to an appliance suitable for the same refrigerant.

NOTE: Special procedures are required for cleaning the aluminum coil in this unit. See Page 7 in this instruction for information.

General

The 7ECX upflow evaporator coils are available cased only and include an externally equalized factory-installed HFC-410A check/expansion valve.

The coil drain pan has a maximum service temperature of 500°F. The drain pan must be at least 2" away from a standard gas-fired furnace heat exchanger and at least 4"-6" away from any drum-type or oil-fired furnace heat exchanger, depending on furnace model. Closer spacing may damage the drain pan and cause a leak.

Refer to the Product Specification for the proper use of these coils with specific furnaces, air handlers, condensers and line sets.

These instructions are intended as a general guide and do not supersede local or national codes in any way. Authorities who have jurisdiction should be consulted before installation.

Shipping and Packing List

Package 1 of 1 contains:

1 – 7ECX evaporator coil

Check the components for shipping damage; if found, immediately contact the last carrier.

Releasing Air Charge

CAUTION

The coil is shipped from the factory pressurized with dry air. Pierce a hole in the rubber plug that seals the vapor line to relieve the pressure before removing the plugs.

NOTE: If there is no pressure released when the vapor line rubber plug is pierced, check the coil for leaks before continuing with the installation.

The 7ECX coils are shipped with a 10 ± 3 psi dry air holding charge. Puncture the suction line rubber plug to release the charge. Remove the rubber plug. Ensure that the coil is void of pressure.

Installation

Air Leakage

All indoor cabinets **MUST** be taped after installation to seal against any air leaks. System performance and efficiency will be reduced if air leakage exists.

WARNING

Risk of explosion or fire.

Can cause injury or death.

Recover all refrigerant to relieve pressure before opening the system.

Install the furnace or air handler and condensing unit according to the installation instructions provided with the unit.

Position the cased coil on top of the furnace or air handler cabinet and secure it using field-provided screws.

NOTE: If the coil is to be installed on an oil furnace, it may be necessary to install a field-installed transition between the furnace and the coil to prevent airflow restriction and possible damage to the coil drain pan. See the oil furnace installation instructions for details.

NOTE: The coil cabinet has six screw clearance holes which should be aligned with the furnace engagement holes. Secure the coil cabinet to the furnace or air handler using six field-provided #8 X 1" screws.

Refrigerant Line Connections

Line Sizes

The refrigerant line sets should be sized according to the recommendations given in the condensing unit installation instructions. Use Table 1 to determine correct braze connection sizes. A field-provided adapter may be required to match line set connections.

Model Number	Suction	Liquid
-18/24, -24, -30, -30/36, -36	3/4 Inch	3/8 Inch
-48, -49, -50/60, -60	7/8 Inch	

Table 1. Refrigerant Line Connections

Replacement Parts

If replacement parts are necessary, order kit 69J46. The kit includes:

- 10 – Brass nuts for liquid line assemblies
- 20 – Teflon rings
- 10 – Liquid line orifice housings
- 10 Liquid line assemblies

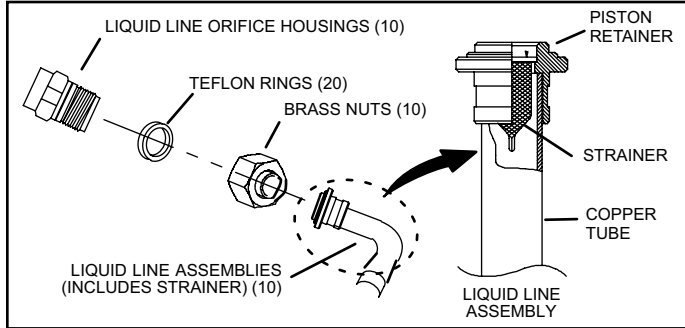

Figure 1. 69J46 Kit Components

Brazing Guidelines

NOTE: For R454B refrigerant installations, do not braze the line set to the evaporator coil until the outdoor unit is installed. Line set joint sleeves must be installed on the liquid and suction lines prior to line set brazing. Refer to R454B Coil Conversion Kit (26Z69) instructions for installation details.

Use a silver alloy brazing rod (5 or 6 percent silver alloy for copper-to-copper connections or 45 percent silver alloy for copper-to-brass or copper-to-steel connections).

Before making brazed connections, place a field-provided heat shield, such as a wet rag, against the unit cabinet and around the piping stubs, expansion valve, sensing bulb and line set joint sleeve, if present. The heat shield must be in place to prevent heat damage during brazing. See Figure 2.

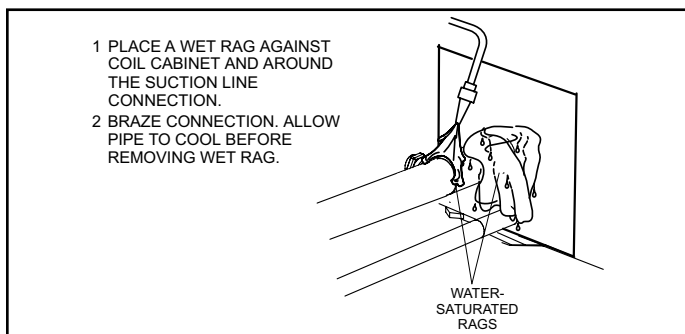

Figure 2. Braze Refrigerant Lines

Suction Line Connection

Use the following procedure to connect the suction line to the indoor coil:

1. Remove rubber plug from the stubbed connection.
2. Position the properly sized refrigerant piping and make the brazed connection following the brazing guidelines.
3. Do not remove the water-saturated rags from the cabinet and piping until the piping has cooled completely.

7ECX Liquid Line Connection

7ECX coils include a factory-installed HFC-410A check/expansion valve metering device.

Connect the properly sized field-provided liquid line to the liquid line stub as shown in Figure 3 using one of the following procedures:

1. Position the properly sized refrigerant piping and make the brazed connection following the brazing guidelines.
2. Do not remove the water-saturated rags from the cabinet and piping until the piping has cooled completely.

OR

1. Cut the copper liquid line on a vertical or horizontal section. Use a field-provided coupling to join the properly sized field-provided refrigerant piping and the liquid line stub on the coil. Follow the brazing guidelines.
2. Do not remove the water-saturated rags from the cabinet and piping until the piping has cooled completely.

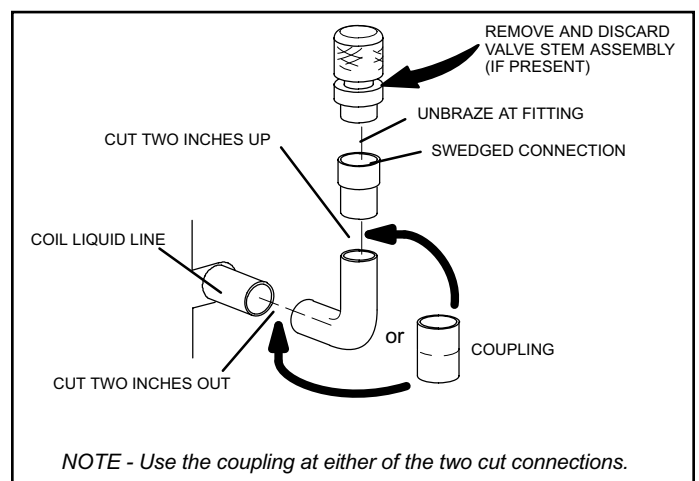

Figure 3. 7ECX Liquid Line Connections

Leak Testing, Evacuating and Charging

NOTE: Refrigerant system installations shall be installed and tested per ASHRAE Standard 15.2, Section 10.0 (latest edition).

Refer to the outdoor unit instruction for leak testing, evacuating and charging procedures. Always leak check entire system before charging.

The following best practices are recommended to ensure better condensate removal:

- Main and overflow drain lines should NOT be smaller than both drain connections at drain pan.
- Overflow drain line should run to an area where homeowner will notice drainage.
- It is recommended that the overflow drain line be vented and a trap installed. Refer to local codes.

Sealing Ducts

Ensure that the duct is secured and all joints are properly sealed to the coil cabinet flanges.

⚠ WARNING

There must be an airtight seal between the bottom of the furnace and the return air plenum. Use fiberglass sealing strips, caulking, or equivalent sealing method between the plenum and the air handler cabinet to ensure a tight seal. Return air must not be drawn from a room where the air handler or any gas-fueled appliance (i.e., water heater), or carbon monoxide-producing device (i.e., wood fireplace) is installed.

⚠ IMPORTANT

DUCT SYSTEM SIZING - The duct system should be properly sized and installed according to the ASHRAE Standard Manual D. The supply and return air duct systems should be designed for the cfm and static requirements of the job. Consult the blower performance chart in the unit installation instructions to verify that the blower meets the application requirements.

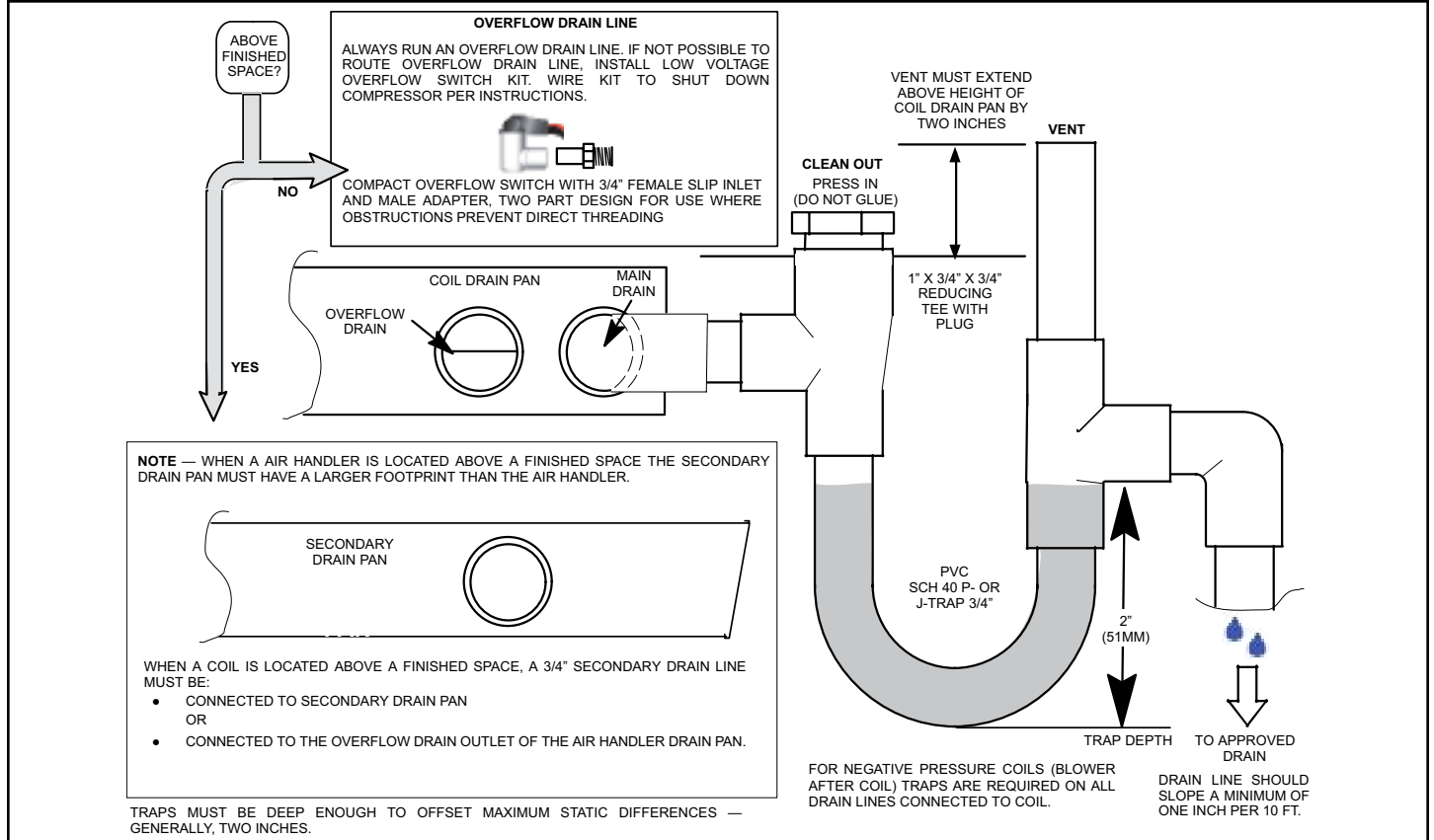

Figure 4. Typical Main and Overflow Drain Installations

Condensate Drain Connections

Main Drain

Connect the main drain and route drain tubing downward to drain line or sump. Do not connect drain to a closed waste system. See Figure 4 for typical drain trap configuration.

Overflow Drain

It is recommended that the overflow drain stub be connected to an overflow drain line for all units. If the overflow drain is not connected to a drain line, it must be plugged with the provided cap.

IMPORTANT

After removal of drain pan plug(s), check drain hole(s) to verify that drain opening is fully open and free of any debris. Also check to make sure that no debris has fallen into the drain pan during installation that may plug up the drain opening.

Condensate Drain Recommendations

The following practices are recommended to ensure better condensate removal:

- Main and overflow drain lines should **NOT** be smaller than both drain connections at drain pan.
- Overflow drain line should run to an area where homeowner will notice drainage.
- It is recommended that the overflow drain line be vented and a trap installed. Refer to local codes.

Blower Speed Selection

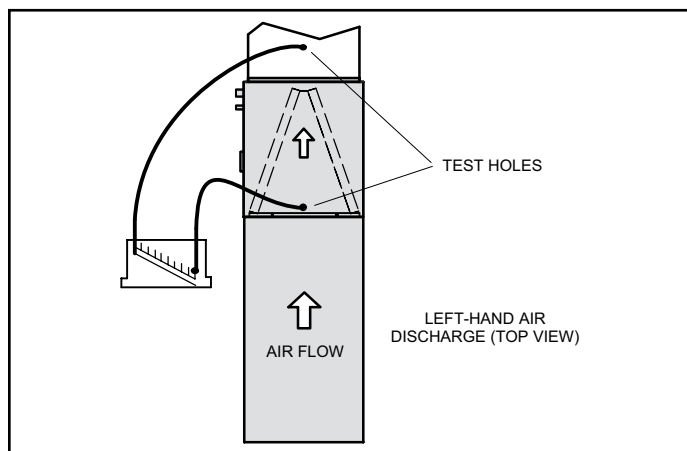

Figure 5. Static Pressure Test

CAUTION

Take care when drilling test holes into the furnace flange and the duct. Drill holes away from refrigerant piping. Test holes should be drilled where specified in order to avoid unit damage.

Proper air volume must be provided over the evaporator coil. Select a blower motor speed tap that will provide 400 ± 50 CFM per 12,000 Btuh of cooling capacity (wet coil). A static pressure reading must be taken to see if the pressure drop falls within the proper range. See Table 2.

To ensure accuracy, air must be read from below the coil and above the coil. See Figure 5 for an example to obtain an accurate reading.

1. Drill one 5/16" air test hole into the delta plate between the coil slabs.
2. Drill one 5/16" air test hole into the duct above the top of the coil.
3. Connect the **instrument for static pressure measurement hoses** to the air entering side of coil. Insert the hoses so that 1/4" extends inside the duct or end seal. Seal around holes with Permagem®.
4. Turn on electrical power to the furnace and set the thermostat to initiate a cooling demand.
5. Table 2 lists air volumes and equivalent static pressure readings for these units. Observe the static pressure reading. If the reading is below the required air volume, increase the blower speed; if the reading is above the required air volume, decrease the blower speed. Refer to the furnace wiring diagram for blower speed settings.
6. When the required static pressure readings are obtained, remove the test hose lines and insert snap hole plugs into test holes.

Cabinet		Vol: CFM	Drop: in. w.g.	
Model	Width in.		Dry	Wet
18/24A	14-1/2	600	.11	.17
	14-1/2	800	.18	.25
18/24B	17-1/2	600	.11	.17
	17-1/2	800	.18	.25
24A	14-1/2	800	.16	.18
24B	17-1/2	800	.16	.18
30A	14-1/2	1000	.18	.20
30B	17-1/2	1000	.18	.20
30/36A	14-1/2	1000	.19	.21
	14-1/2	1200	.27	.30
30/36B	17-1/2	1000	.13	.16
	17-1/2	1200	.17	.21
30/36C	21	1000	.13	.16
	21	1200	.17	.21
36A	14-1/2	1200	.27	.30
36B	17-1/2	1200	.17	.21
48B	17-1/2	1400	.23	.24
	17-1/2	1600	.30	.31
48C	21	1400	.13	.16
	21	1600	.16	.20
49C	21	1600	.17	.22
50/60C	21	1600	.23	.29
60C	21	2000	.29	.34
60D	24-1/2	2000	.21	.27

Table 2. Air Volume / Static Pressure Drop Across Coil

Nameplate Marking

Prior to installing the front panel, mark the unit nameplate to permanently identify the refrigerant configuration.

Nameplate example shown in Figure 6 below:

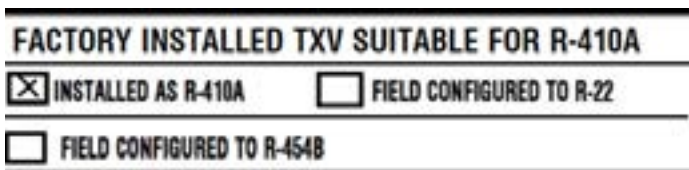

Figure 6. Nameplate Marking

Maintenance

NOTE

Failure to follow instructions will cause damage to the unit.

This unit is equipped with an aluminum coil. Aluminum coils may be damaged by exposure to solutions with a pH below 5 or above 9. The aluminum coil should be cleaned using potable water at a moderate pressure (less than 50psi). If the coil cannot be cleaned using water alone, it is recommended to use a coil cleaner with a pH in the range of 5 to 9. The coil must be rinsed thoroughly after cleaning.

In coastal areas, the coil should be cleaned with potable water several times per year to avoid corrosive buildup (salt).

A trained technician or service agency must perform maintenance and service on equipment. At the beginning of each heating or cooling season, indoor coils should be cleaned.

Do not use hydrofluoric acid, alkaline, or similar chemicals on coils. These chemicals are not necessary to dissolve salt, and may damage the fin coating. Acid washes are used to dissolve oils and greases, which generally are not present on most installations.

Do not use alkaline washes. Alkaline washes are useful for dissolving oxides such as zinc oxide, aluminum oxide, and iron oxide (rust). However, these three oxides are more corrosion resistant than base metals, so dissolving or removing them will cause an increase in corrosion.

Cleaning the Coil

The coil should be inspected twice each year and cleaned at least once per year or more, if necessary. Indoor coil cleaning should be performed by a licensed professional service technician (or equivalent).

CAUTION

A damaged coil fin can affect equipment operation and performance. Do not use flame, high-pressure water, steam, or volatile cleaners on fins or tubing surfaces. If cleaning requires the use of acidic or alkaline cleaners, follow the manufacturer's instructions. Thoroughly flush cleaner from all equipment components. (Be careful to prevent damage or corrosion of the components connected to the system or areas surrounding the equipment being cleaned.)

1. Before beginning this or any other maintenance, turn off all power to the indoor unit at the main unit disconnect switch. It is also recommended that you

wear personal protective gear: safety glasses and/or a face shield, waterproof clothing and gloves.

2. Remove the coil from the cabinet or plenum, and take the coil to an appropriate place to clean it.
3. Vacuum or brush the coil to remove matted and surface debris from the fins. Use vacuum attachments and /or brushes that are non-destructive to fins.
4. If oil deposits are present, spray the coil with a mild household liquid detergent to soften deposits. Do not leave the detergent on the coil for more than 10 minutes. Flush the coil thoroughly with potable water.

NOTE: For units in coastal regions, fresh water will dissolve away any salt deposits. (Wash coils with fresh water at least every six months.)

5. Spray the coil at a vertical angle of 30 to 45 degrees with a constant stream of water at moderate pressure. A pressure washer with a fan nozzle will work best. Do not spray the coil from a horizontal direction.
6. Direct the spray so that any debris is washed out of the coil and base pan. For most residential units, hot water is not necessary.

NOTE: Attempting to back flush from the inside of the coil will require removing parts from the unit, and it may be very difficult to flush the whole coil surface. Attempting to blow water through a coil will slow the water stream and reduce the flushing action of the outer fin surface.

7. Replace the coil into the cabinet or plenum. Ensure that you have followed the proper procedure for routing and securing the refrigerant tubing.

IMPORTANT

Ensure that the distributor lines are not rubbing together or kinked. All tubes must have enough clearance from other metal parts. Use wire ties to secure tubes to prevent movement that could cause the refrigerant tubing to fail.

Use of Coil-Furnace System During Construction

Allied does not recommend the use of its coil-furnace system during any phase of construction. Very low return air temperatures, harmful vapors and operation of the unit with clogged or misplaced filters will damage the unit.

Coils may be used for heating (heat pumps) or cooling of buildings under construction, if the following conditions are met:

- A room thermostat must control the air handler. The use of fixed jumpers is not allowed.
- Air filter must be installed in the system and must be maintained during construction.
- Air filter must be replaced upon construction completion.

- The evaporator coil, furnace supply fan assembly and duct system must be thoroughly cleaned following final construction clean-up.
- All coil and furnace operating conditions must be verified according to these installation instructions.
- **R454B applications only:** If refrigerant leak detection sensor kit has been installed, ensure that sensor opening is clear and free of debris. Follow sensor maintenance recommendations as outlined in sensor kit instructions.

Decommissioning

Before decommissioning, it is essential that the technician is completely familiar with the equipment and all its detail. It is recommended good practice that all refrigerants are recovered safely.

Before performing this task, an oil and refrigerant sample shall be taken in case analysis is required prior to re-use of recovered refrigerant. It is also essential that electrical power is available before starting decommissioning.

1. Become familiar with the equipment and its operation.
2. Isolate system electrically.
3. Before attempting the procedure, ensure that:
 - a. mechanical handling equipment is available, if required, for handling refrigerant cylinders;
 - b. all personal protective equipment is available and being used correctly;
 - c. the recovery process is supervised at all times by a competent person;
 - d. recovery equipment and cylinders conform to the appropriate standards.
4. Pump down refrigerant system, if possible.
5. If a vacuum is not possible, make a manifold so that refrigerant can be removed from various parts of the system.
6. Make sure that cylinder is situated on the scales before recovery takes place.
7. Start the recovery machine and operate in accordance with instructions.
8. Do not overfill cylinders (no more than 80% volume liquid charge).
9. Do not exceed the maximum working pressure of the cylinder, even temporarily.
10. When the cylinders have been filled correctly and the process completed, make sure that the cylinders and the equipment are removed from site promptly and all isolation valves on the equipment are closed off.
11. Recovered refrigerant shall not be charged into another REFRIGERATING SYSTEM unless it has been cleaned and checked.