

INSTALLATION INSTRUCTIONS

7AH1AV

Multi-Position Air Handler

R454B

This manual must be left with the homeowner for future reference.



Table of Contents

General Information	3
Wiring Diagrams	4
BDC3 Blower Control	6
Adjusting the Blower Speed	6
Requirements	11
Unit Dimensions – Upflow	12
Unit Dimensions – Horiz.	13
Installation Clearances	14
Installation	14
Sensor / Bracket Installation.....	17
Condensate Drain.....	20
Duct System and Filters	21
Brazing Refrigerant Lines	22
Sealing the Unit	25
Electrical Connections	25
Check-out Procedures	26
Maintenance	27
Repairing or Replacing Cabinet Insulation	27
Professional Maintenance	28
Sensor Maintenance	28
Modes of Operation	28
Start Up Test Procedure	30
Decommissioning	31

⚠ WARNING

Every working procedure that affects safety means shall only be carried out by competent persons. This appliance is not to be used by persons (including children) with reduced physical, sensory or mental capabilities, or lack of experience and knowledge, unless they have been given supervision or instruction concerning use of the appliance by a person responsible for their safety. Children should be supervised to ensure they do not play with the appliance.

⚠ WARNING

Maximum Altitude of application is 10,500 ft. (3,200 m) above sea level.

⚠ WARNING

Improper installation, adjustment, alteration, service or maintenance can cause property damage, personal injury or loss of life. Installation and service must be performed by a licensed professional HVAC installer or equivalent, service agency, or the gas supplier.

⚠ CAUTION

Servicing shall be performed only as recommended by the manufacturer.

NOTE – This unit is a PARTIAL UNIT AIR CONDITIONER, complying with PARTIAL UNIT requirements of this Standard, and must only be connected to other units that have been confirmed as complying to corresponding PARTIAL UNIT requirements of this Standard, UL 60335-2-40/CSA C22.2 No. 60335-2-40, or UL 1995/CSA C22.2 No 236. Partial units shall only be connected to an appliance suitable for the same refrigerant.

Allied Air Enterprises LLC
 215 Metropolitan Drive
 West Columbia, SC 29170



(P) 508442-01

⚠ CAUTION

Leak Detection System installed. Unit must be powered except for service.

⚠ IMPORTANT

The Clean Air Act of 1990 bans the intentional venting of refrigerant (CFCs, HCFCs and HFCs) as of July 1, 1992. Approved methods of recovery, recycling or reclaiming must be followed. Fines and/or incarceration may be levied for noncompliance.

⚠ WARNING

Ducts connected to an appliance shall not contain a potential ignition source

⚠ WARNING

- Do not use means to accelerate the defrosting process or to clean, other than those recommended by the manufacturer.
- The appliance shall be stored in a room without continuously operating ignition sources (for example: open flames, an operating gas appliance, or an operating electric heater).
- Do not pierce or burn.
- Be aware that refrigerants may not contain an odor.

⚠ WARNING

For appliances using A2L refrigerants connected via an air duct system to one or more rooms, only auxiliary devices approved by the appliance manufacturer or declared suitable with the refrigerant shall be installed in connecting ductwork.

⚠ WARNING

Ducts connected to an appliance shall not contain a potential ignition source

⚠ WARNING

Auxiliary devices which may be a potential ignition source shall not be installed in the duct work. Examples of such potential ignition sources are hot surfaces with a temperature exceeding 1,292 F (700°C) and electric switching devices.

⚠ CAUTION

Any service personnel installing, decommissioning, or performing maintenance on the unit must be properly trained with A2L refrigerants

⚠ WARNING

For duct connected appliances, false ceilings or drop ceilings may be used as a return air plenum if a REFRIGERANT DETECTION SYSTEM is provided in the appliance and any external connections are also provided with a sensor immediately below the return air plenum duct joint.

⚠ WARNING

If this appliance is conditioning a space with an area smaller than T_{Amin} , then that space must be without continuously operating open flames (e.g. an operating gas appliance) or other potential ignition sources (e.g. an operating electric heater or similar hot surface). A flame-producing device may be installed in the same space if the device is provided with an effective flame arrest system.

NOTE – R454B is an A2L refrigerant. The system installation must meet the following parameters based upon total refrigerant charge (line set included). T_{Amin} (Total minimum conditioned area) is the minimum allowable conditioned area based upon the total system charge at sea level. Values must be multiplied by altitude adjustment factor at installed altitude.

See tables below

T_{Amin} Table

Charge (lb)	10.0	15.0	20.0	25.0	30.0
Charge (kg)	4.5	6.8	9.1	11.3	13.6
Minimum Conditioned Area (ft ²)	149.9	224.9	299.9	374.8	449.8
Minimum Conditioned Area (m ²)	13.9	20.9	27.9	34.8	41.8

NOTE – Multiply values in *T_{Amin}* table by the Altitude Adjustment Factors to correct *T_{Amin}* based on installed altitude.

Altitude Adjustment Factor

Altitude (m)	0	200	400	600	800	1000	1200	1400	1600
Altitude (ft)	0	660	1310	1970	2620	3280	3940	4590	5250
Adj. Factor	1	1	1	1	1.02	1.05	1.04	1.1	1.12
Altitude (m)	1600	1800	2000	2200	2400	2600	2800	3000	3200
Altitude (ft)	5250	5910	6560	7220	7870	8530	9190	9840	10500
Adj. Factor	1.12	1.15	1.18	1.21	1.25	1.28	1.32	1.36	1.4

General Information

The 7AH1AV series air handler **with all-aluminum coil** is designed for indoor installation only. As shipped, the unit is ready for installation in either upflow or horizontal right-hand air discharge applications. Horizontal drain pan may be repositioned in the field to allow installation in the horizontal left-hand air discharge position. Various accessories are available and listed in the *7AH1AV Specification sheet* for ordering.

This instruction is intended as a general guide and does not supersede local or national codes in any way. Consult authorities having jurisdiction before installation.

IMPORTANT: Special procedures are required for cleaning the all-aluminum coil in this unit. See page 28 in this instruction for information.

Shipping and Packing List

Package 1 of 1 contains:

- 1 – Assembled air handler unit factory-equipped for upflow or horizontal air discharge application (includes upflow and horizontal drain pans and **refrigerant detection system (RDS)**).

Check the air handler for shipping damage; if found, immediately contact the last carrier. Check the unit rating plate to confirm that delivered unit matches order.

Wiring Diagrams

SYSTEM	FIELD JUMPERS
SINGLE STAGE AIR CONDITIONER	NEED ALL
TWO-STAGE AIR CONDITIONER	REMOVE Y1 TO Y2
SINGLE STAGE HEAT PUMP	REMOVE R TO O
TWO-STAGE HEAT PUMP	REMOVE Y1 TO Y2 AND R TO O
TWO-STAGE ELECTRIC HEAT	REMOVE W1 TO W2
TO ACTIVATE DEHUMIDIFICATION	REMOVE R TO DS

WARNING
USE COPPER CONDUCTORS
ONLY

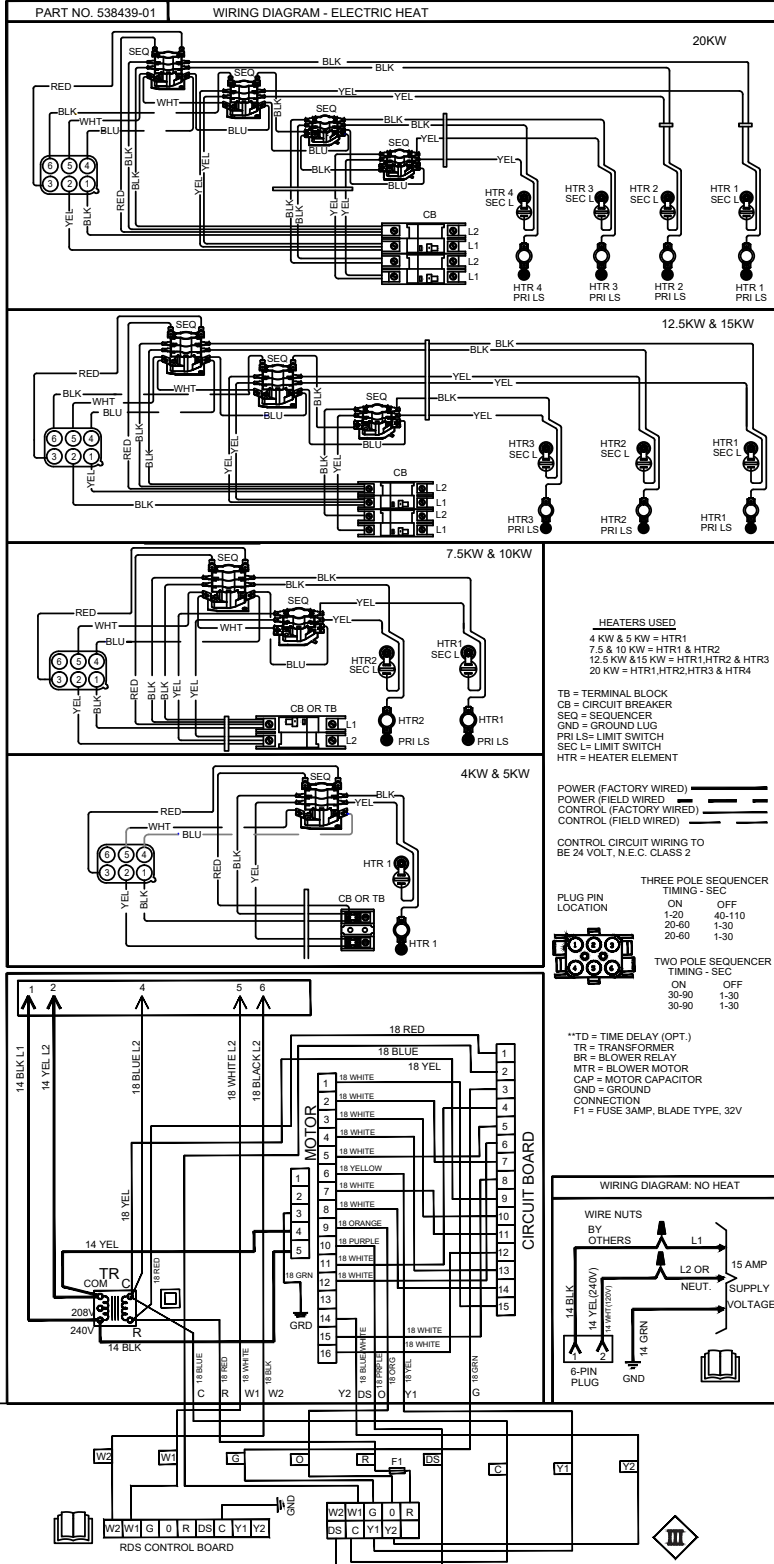

ELECTRIC HEAT
VARIABLE SPEED LABEL WIRING
DIAGRAM

Supplements

Form No. 538439-01

07/25

© 2011

U.S.A.

FIGURE 1. Typical Wiring Diagram – 7AH1AV Air Handler with Electric Heat – (Variable-Speed Motor)

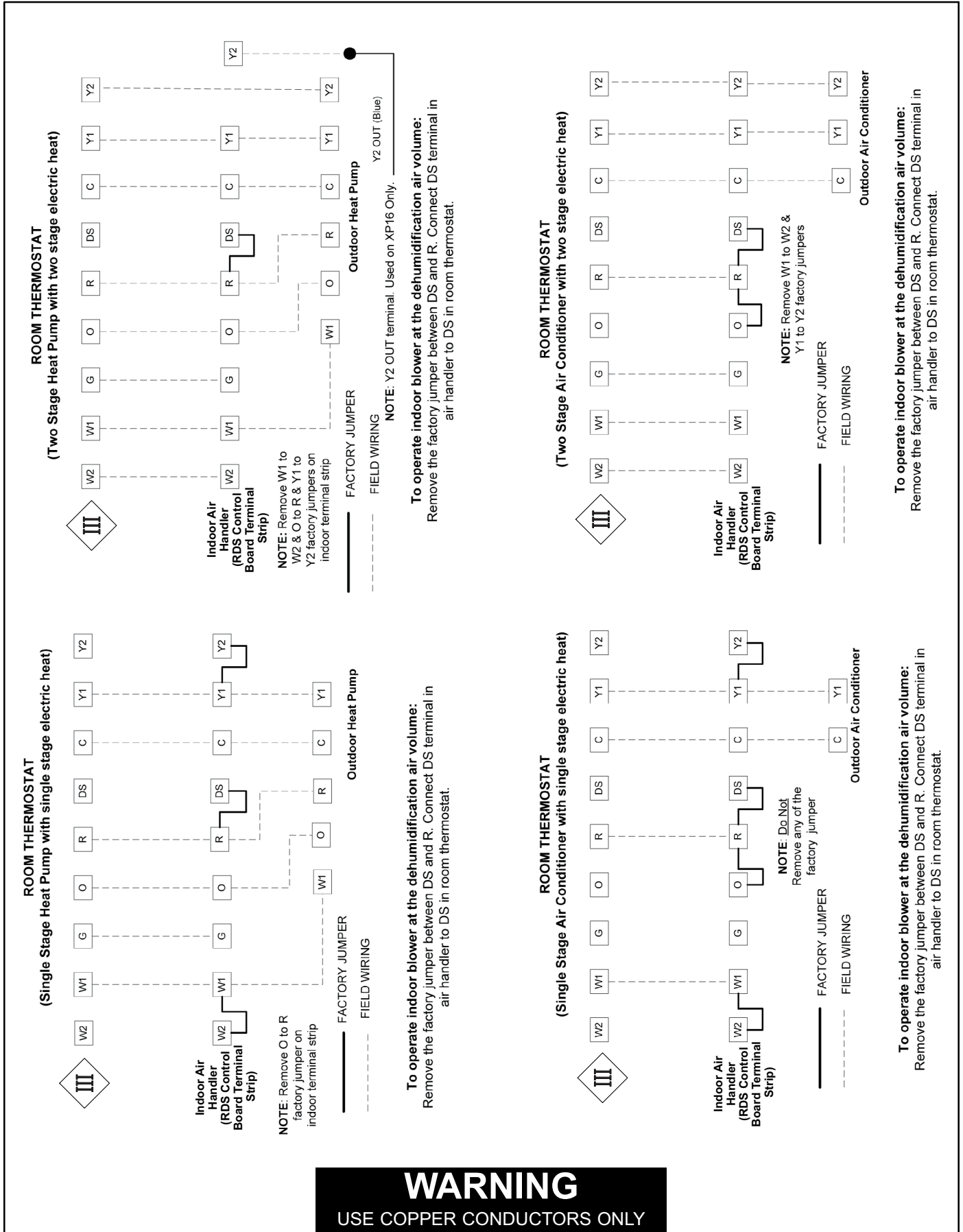

FIGURE 2. Low Voltage Connections (Variable-Speed Motor)

BDC3 Blower Control

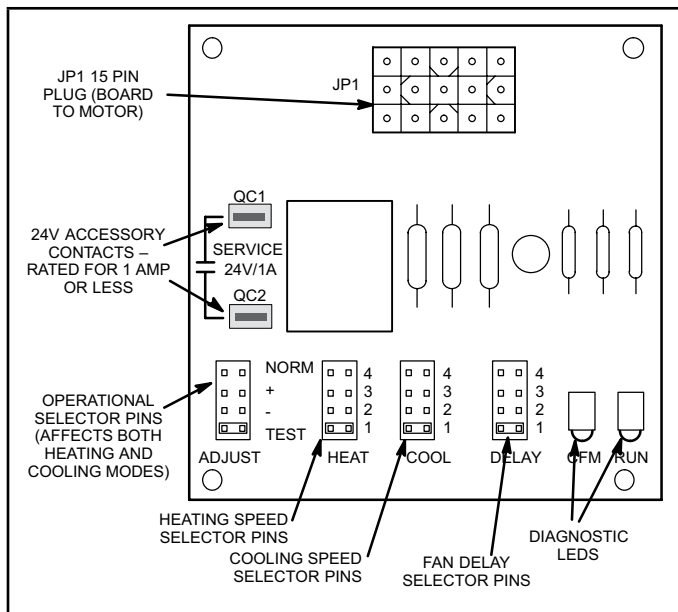

FIGURE 3. BDC3 Variable Speed Control Selections

7AH1AV units are equipped with a variable-speed motor that is capable of maintaining a specified CFM throughout the external static range. A particular CFM can be obtained by positioning jumpers (**COOL**, **HEAT**, and **ADJUST**) on the BDC3 control.

The jumpers are labeled 1, 2, 3, and 4. This indicates the selected air volume (CFM). The **ADJUST** jumper is labeled Test, -, +, and Norm. The - and + pin settings are used to add or subtract a percentage of the CFM selected. The Test jumper is used to operate the motor in the test mode. The delay jumper controls the timing pattern in which the fan delay occurs.

Figure 3 illustrates the BDC3 control. Use tables 2-8 to determine the correct air volume for heat and cool speed taps.

Diagnostic LEDs located on the BDC3 control to assist in servicing the unit. Read the jumper settings section before adjusting blower speed.

Adjusting the Blower Speed

Diagnostic LEDs

- 1 - **RUN LED** indicates there is a demand for the blower motor to run.
- 2 - **CFM LED** indicates the cubic feet per minute at which the unit is operating. The light flashes once for approximately every 100 CFM. For example, if the unit is operating at 1000 CFM, CFM LED will flash 10 times. If the CFM is 1150, CFM LED will flash 11 full times plus one fast or half flash.

At times, the light may appear to flicker or glow. This is normal and occurs when the control is communicating with the motor between cycles.

Move the jumper pins to select the blower speed needed to meet application CFM requirements.

JUMPER SETTINGS

▲ IMPORTANT

Before changing jumper setting, make sure the motor has completely stopped. Any jumper setting change will not take place while the motor is running.

Table 2-8 list the recommended factory blower speed tap selections for 7AH1AV series units. These settings are for nominal tonnage match-ups with the 7AH1AV. When matched with other sizes, it is recommended that the CFM be adjusted to provide approximately 400 CFM per ton.

TABLE 1 Recommended Blower Speed Taps

Air Handler	Speed Tap Selection			
	Cooling		Heating*	
	Note 1 -	Note 2 -	Note 3 -	Note 4 -
7AH1AV-018	COOL PIN #2	COOL PIN #2	HEAT PIN #2	HEAT PIN #2
7AH1AV-024	COOL PIN #3	COOL PIN #3	HEAT PIN #3	HEAT PIN #3
7AH1AV-030	COOL PIN #3	COOL PIN #3	HEAT PIN #3	HEAT PIN #3
7AH1AV-036	COOL PIN #3	COOL PIN #3	HEAT PIN #3	HEAT PIN #3
7AH1AV-042	COOL PIN #3	COOL PIN #3	HEAT PIN #3	HEAT PIN #3
7AH1AV-048	COOL PIN #3	COOL PIN #3	HEAT PIN #3	HEAT PIN #3
7AH1AV-060	COOL PIN #3	COOL PIN #3	HEAT PIN #3	HEAT PIN #3

NOTES -
 1 - Condensing Unit
 2 - Heat Pump
 3 - Condensing Unit with electric heat only
 4 - Heat Pump with electric heat
 * Minimum setting for heat

To change jumper positions, gently pull the jumper off the pins and insert it onto the desired set of pins. The following section outlines the different jumper selections available and conditions associated with each one as illustrated in figure 3.

After the CFM for each application has been determined, the jumper settings must be adjusted to reflect those given in the appropriate tables on the following pages. From the tables, determine which row of CFM volumes most closely matches the desired CFM. Once a specific row has been chosen (+, NORMAL, or -), CFM volumes from other rows cannot be used. Below are descriptions of the jumper selections.

ADJUST JUMPER

The ADJUST pins allow the motor to run at normal speed, slightly higher (approximately 10%) than normal speed, or slightly lower (approximately 10%) than normal speed.

The tables on the following pages list three rows (+, NOR-

MAL, and -) with their respective CFM volumes. Notice in table 3, for example, that the normal adjustment setting for Table 3, "heat speed" position #4 shows 1,050 CFM. The + adjustment setting for that position is 1120 CFM and for the - adjustment setting is 915 CFM. After the adjustment setting has been determined, choose the remaining speed jumper settings from those offered in the table in that row. The TEST pin is available to bypass the BDC3 control and run the motor at approximately 70% to test that the motor is operational. This is beneficial primarily in troubleshooting. G must be energized for motor to run.

COOL JUMPER

The **COOL** jumper is used to determine the CFM during either cooling or heat pump operation without a call for electric heat. These jumper selections are activated for cooling when Y2 and DS terminals in the 7AH1AV are energized. The are activated for heating when Y2 is energized.

Applications non-communicating Allied thermostat will provide 70% of the **COOL** CFM during first-stage cooling for two-stage outdoor units. 100% of **COOL** speed is provided for systems with a single-stage outdoor unit.

Applications non-communicating Allied thermostat, but no demand for de-humidification will operate as follows: during a first-stage cooling call (two-stage outdoor unit),

the air volume is 70% of the **COOL** jumper selection. This arrangement provides for additional dehumidification during standard first-stage cooling. See the tables that follow for various scenarios concerning use of the thermostat and the 7AH1AV series unit.

For applications with zone control, the air handler CFM volume is determined by the control center. The minimum blower speed is predetermined at 250 CFM for -018, -024, -030 and -036 units and 450 CFM for -042, -048 and -060 units. This speed is not adjustable. See footnotes in the blower performance tables.

With the thermostat set for *Continuous Fan* and without a call for heating or cooling, the 7AH1AV provides 50% of the **COOL** CFM selected.

NOTE - For two-stage heat pumps, air handler will operate at 70% of the **COOL** selection until supplemental electric heat is demanded. At that time, the air handler will operate at the selected **HEAT** speed. This arrangement provides warmer supply air during second-stage heating.

▲ IMPORTANT
Minimum Air Flow when RDS initiates mitigation is factory set at 350 CFM Per Ton.

TABLE 2

BLOWER DATA

7AH1AV-018 BLOWER PERFORMANCE

0 through 0.80 in. w.g. External Static Pressure Range

"ADJUST" Jumper Setting	Jumper Speed Positions											
	"HEAT" Speed				First Stage "COOL" Speed				Second Stage "COOL" Speed			
	1	2	3	4	1	2	3	4	1	2	3	4
	cfm	cfm	cfm	cfm	cfm	cfm	cfm	cfm	cfm	cfm	cfm	cfm
+	500	705	925	1150	365	520	665	810	500	705	925	1150
NORM	465	650	850	1050	350	485	610	740	465	650	850	1050
-	420	600	760	950	320	425	560	680	420	600	760	950

NOTES - The effect of static pressure, filter and electric heater resistance is included in the air volumes listed.
First stage cooling air volume is 70% of COOL speed setting. Continuous blower speed is approximately 50% of COOL speed setting.

TABLE 3

BLOWER DATA

7AH1AV-024 BLOWER PERFORMANCE

0 through 0.80 in. w.g. External Static Pressure Range

"ADJUST" Jumper Setting	Jumper Speed Positions											
	"HEAT" Speed				First Stage "COOL" Speed				Second Stage "COOL" Speed			
	1	2	3	4	1	2	3	4	1	2	3	4
	cfm	cfm	cfm	cfm	cfm	cfm	cfm	cfm	cfm	cfm	cfm	cfm
+	450	670	900	1120	340	450	650	770	450	670	900	1120
NORM	420	620	820	1050	300	400	600	700	420	620	820	1050
-	390	570	750	915	280	390	500	650	390	570	750	915

NOTES - The effect of static pressure, filter and electric heater resistance is included in the air volumes listed.
First stage cooling air volume is 70% of COOL speed setting. Continuous blower speed is approximately 50% of COOL speed setting.

TABLE 4

BLOWER DATA

7AH1AV-030 BLOWER PERFORMANCE

0 through 0.80 in. w.g. External Static Pressure Range

"ADJUST" Jumper Setting	Jumper Speed Positions											
	"HEAT" Speed				First Stage "COOL" Speed				Second Stage "COOL" Speed			
	1	2	3	4	1	2	3	4	1	2	3	4
	cfm	cfm	cfm	cfm	cfm	cfm	cfm	cfm	cfm	cfm	cfm	cfm
+	680	885	1115	1340	490	635	770	930	680	885	1115	1340
NORM	620	810	1020	1220	440	575	715	845	620	810	1020	1220
-	550	725	905	1100	411	530	645	755	550	725	905	1100

NOTES - The effect of static pressure, filter and electric heater resistance is included in the air volumes listed.
First stage cooling air volume is 70% of COOL speed setting. Continuous blower speed is approximately 50% of COOL speed setting.

TABLE 5

BLOWER DATA

7AH1AV-036 BLOWER PERFORMANCE

0 through 0.80 in. w.g. External Static Pressure Range

"ADJUST" Jumper Setting	Jumper Speed Positions											
	"HEAT" Speed				First Stage "COOL" Speed				Second Stage "COOL" Speed			
	1	2	3	4	1	2	3	4	1	2	3	4
	cfm	cfm	cfm	cfm	cfm	cfm	cfm	cfm	cfm	cfm	cfm	cfm
+	930	1155	1390	1530	640	815	970	1150	930	1155	1390	1530
NORM	830	1050	1260	1450	590	725	875	1025	830	1050	1260	1450
-	740	940	1135	1330	545	650	780	910	740	940	1135	1330

NOTES - The effect of static pressure, filter and electric heater resistance is included in the air volumes listed.
First stage cooling air volume is 70% of COOL speed setting. Continuous blower speed is approximately 50% of COOL speed setting.

TABLE 6

BLOWER DATA

7AH1AV-042 BLOWER PERFORMANCE

0 through 0.80 in. w.g. External Static Pressure Range

"ADJUST" Jumper Setting	Jumper Speed Positions											
	"HEAT" Speed				First Stage "COOL" Speed				Second Stage "COOL" Speed			
	1	2	3	4	1	2	3	4	1	2	3	4
	cfm	cfm	cfm	cfm	cfm	cfm	cfm	cfm	cfm	cfm	cfm	cfm
+	1130	1370	1575	1810	780	945	1110	1275	1130	1370	1575	1810
NORM	1020	1255	1440	1650	710	860	1000	1160	1020	1255	1440	1650
-	920	1135	1300	1490	670	780	910	1040	920	1135	1300	1490

NOTES - The effect of static pressure, filter and electric heater resistance is included in the air volumes listed.
First stage cooling air volume is 70% of COOL speed setting. Continuous blower speed is approximately 50% of COOL speed setting.

TABLE 7

BLOWER DATA

7AH1AV-048 BLOWER PERFORMANCE

0 through 0.80 in. w.g. External Static Pressure Range

"ADJUST" Jumper Setting	Jumper Speed Positions											
	"HEAT" Speed				First Stage "COOL" Speed				Second Stage "COOL" Speed			
	1	2	3	4	1	2	3	4	1	2	3	4
	cfm	cfm	cfm	cfm	cfm	cfm	cfm	cfm	cfm	cfm	cfm	cfm
+	1375	1600	1820	2185	960	1125	1285	1620	1375	1600	1820	2185
NORM	1260	1455	1655	2085	885	1035	1185	1475	1260	1455	1655	2085
-	1125	1310	1490	1885	790	925	1060	1330	1125	1310	1490	1885

NOTES - The effect of static pressure, filter and electric heater resistance is included in the air volumes listed.
First stage cooling air volume is 70% of COOL speed setting. Continuous blower speed is approximately 50% of COOL speed setting.

TABLE 8

BLOWER DATA

7AH1AV-060 BLOWER PERFORMANCE

0 through 0.80 in. w.g. External Static Pressure Range

"ADJUST" Jumper Setting	Jumper Speed Positions											
	"HEAT" Speed				First Stage "COOL" Speed				Second Stage "COOL" Speed			
	1	2	3	4	1	2	3	4	1	2	3	4
	cfm	cfm	cfm	cfm	cfm	cfm	cfm	cfm	cfm	cfm	cfm	cfm
+	1600	1835	2030	2190	1110	1285	1380	1615	1600	1835	2030	2190
NORM	1465	1675	1855	2085	1000	1160	1250	1470	1465	1675	1855	2085
-	1320	1500	1675	1890	895	1035	1115	1320	1320	1500	1675	1890

NOTES - The effect of static pressure, filter and electric heater resistance is included in the air volumes listed.
First stage cooling air volume is 70% of COOL speed setting. Continuous blower speed is approximately 50% of COOL speed setting.

TABLE 9. 7AH1AV Thermostat and Single-Stage Outdoor Unit Operating Sequence

Operating Sequence		System Demand								System Response		
System Condition	Step	Thermostat Demand						Relative Humidity		Com-pressor	Air Handler CFM (COOL)	Comments
		Y1	Y2	O	G	W1	W2	Status	D			
NO CALL FOR DEHUMIDIFICATION												
Normal Operation	1	On		On	On			Acceptable	24 VAC	High	100%	Compressor and indoor air handler follow thermostat demand
BASIC MODE (only active on a Y1 thermostat demand)												
Normal Operation	1	On		On	On			Acceptable	24 VAC	High	100%	Thermostat energizes Y1 and de-energizes D on a call for dehumidification
Dehumidification Call	2	On		On	On			Demand	0 VAC	High	60%/65% 70%*	
PRECISION MODE (operates independent of a Y1 thermostat demand)												
Normal Operation	1	On		On	On			Acceptable	24 VAC	High	100%	Dehumidification mode begins when humidity is greater than set point
Dehumidification Call	2	On		On	On			Demand	0 VAC	High	60%/65% 70%*	
Dehumidification Call ONLY	1	On		On	On			Demand	0 VAC	High	60%/65% 70%*	Thermostat will try to maintain room humidity setpoint by allowing the room space to maintain a cooler room thermostat setpoint**
Jumpers at indoor unit with a single stage outdoor unit With Condensing unit - Y1 to Y2 and R to O With Heat Pump - Y1 to Y2												

* During dehumidification, cooling air handler speed is as follows: 70% of COOL cfm for 018, 024, 030; 65% for 036; 60% for 042, 048 and 060 units.

** Thermostat will maintain the room temperature up to 2°F (1.2°C) cooler than the room thermostat setting in precision mode.

TABLE 10. 7AH1AV Thermostat and Two-Stage Outdoor Unit Operating Sequence

Operating Sequence		System Demand								System Response		
System Condition	Step	Thermostat Demand						Relative Humidity		Com-pressor	Air Handler CFM (COOL)	Comments
		Y1	Y2	O	G	W1	W2	Status	D			
NO CALL FOR DEHUMIDIFICATION												
Normal Operation - Y1	1	On		On	On			Acceptable	24 VAC	Low	70%	Compressor and indoor air handler follow thermostat demand
Normal Operation - Y2	2	On	On	On	On			Acceptable	24 VAC	High	100%	
Room Thermostat Calls for First-Stage Cooling												
BASIC MODE (only active on a Y1 thermostat demand)												
Normal Operation	1	On		On	On			Acceptable	24 VAC	Low	70%	Thermostat energizes Y2 and de-energizes D on a call for dehumidification
Dehumidification Call	2	On	On	On	On			Demand	24 VAC	High	60%/65% 70%*	
PRECISION MODE (operates independent of a Y1 thermostat demand)												
Normal Operation	1	On		On	On			Acceptable	24 VAC	Low	70%	Dehumidification mode begins when humidity is greater than set point
Dehumidification Call	2	On	On	On	On			Demand	0 VAC	High	60%/65% 70%*	
Dehumidification Call ONLY	1	On	On	On	On			Demand	0 VAC	High	60%/65% 70%*	Thermostat will try to maintain room humidity setpoint by allowing the room space to maintain a cooler room thermostat setpoint**
Room Thermostat Calls for First- and Second-Stage Cooling												
BASIC MODE (only active on a Y1 thermostat demand)												
Normal Operation	1	On	On	On	On			Acceptable	24 VAC	High	100%	Thermostat energizes Y2 and de-energizes D on a call for dehumidification
Dehumidification Call	2	On	On	On	On			Demand	0 VAC	High	60%/65% 70%*	
PRECISION MODE (operates independent of a Y1 thermostat demand)												
Normal Operation	1	On	On	On	On			Acceptable	24 VAC	High	100%	Dehumidification mode begins when humidity is greater than set point
Dehumidification Call	2	On	On	On	On			Demand	0 VAC	High	60%/65% 70%*	
Dehumidification Call ONLY	1	On	On	On	On			Demand	0 VAC	High	60%/65% 70%*	Thermostat will try to maintain room humidity setpoint by allowing the room space to maintain a cooler room thermostat setpoint**
Jumpers at indoor unit with a two-stage outdoor unit With Condensing unit - Y2 and R to O With Heat Pump - none												
* During dehumidification, cooling air handler speed is as follows: 70% of COOL cfm for 018, 024, 030; 65% for 036; 60% for 042, 048 and 060 units. ** Thermostat will maintain the room temperature up to 2°F (1.2°C) cooler than the room thermostat setting in precision mode.												

HEAT JUMPER

The **HEAT** jumper is used to determine CFM during electric heat operation only. These jumper selections are activated only when W1 is energized.

DELAY JUMPER

The **DELAY** jumper is used to set the specific motor fan operation during cooling mode. Depending on the application, one of four options may be chosen by moving the jumper to the appropriate set of pins.

#1 Pins Jumpered

- A- Motor runs at 100% until demand is satisfied.
- B- Once demand is met, motor ramps down to stop.

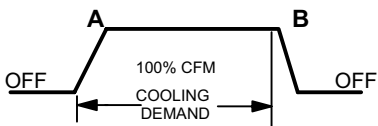

#2 Pins Jumpered

- A- Motor runs at 100% until demand is satisfied.
- B- Once demand is met, motor runs at 100% for 45 seconds.
- C- Motor ramps down to stop.

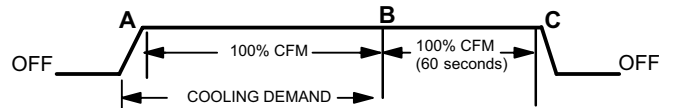

#3 Pins Jumpered

- A- Motor runs at 82% for approximately 7-1/2 minutes. If demand has not been satisfied after 7-1/2 minutes.
- B- Motor runs at 100% until demand is satisfied.
- C- Once demand is met, motor ramps down to stop.

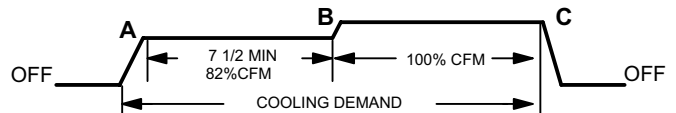

#4 Pins Jumpered

- A- Motor ramps up to 82%.
- B- Motor then runs at 82% for approximately 7-1/2 minutes. If demand has not been satisfied after 7-1/2 minutes,
- C- Motor runs at 100% until demand is satisfied.
- D- Once demand is met, motor ramps down to stop.

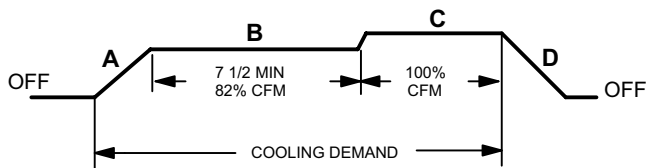

Requirements

⚠ WARNING

Excessive Weight Hazard - Use two or more people when moving and installing the unit. Failure to do so can result in back or other type of injury.

⚠ IMPORTANT

7AH1AV units include a factory-installed check/expansion valve which will provide optimal refrigerant control and system performance with outdoor units of varying capacities. These units must be installed as a part of a matched system as outlined in the 7AH1AV Specification sheet.

These instructions are intended as a general guide and do not supersede local or national codes in any way. Consult authorities having jurisdiction before installation.

Compliance with all local, state, or national codes pertaining to this type of equipment should be determined prior to installation. Read this instruction manual, as well as the instructions supplied in separate equipment, before starting the installation.

In addition to conforming to manufacturer's installation instructions and local municipal building codes, installation of Allied air handler units (with or without optional electric heat), MUST conform with National Fire Protection Association (NFPA) standards: "Standard for Installation of Air Conditioning and Ventilation Systems" (NFPA No. 90A) and "Standard for Installation of Residence Type Warm Air Heating and Air Conditioning Systems" (NFPA No. 90B).

All models are designed for indoor installation only. The installation of the air handler, field wiring, duct system, etc. must conform to the requirements of the National Electrical Code, ANSI/NFPA No. 70 (latest edition) in the United States, and any state laws, and local ordinances (including plumbing or waste water codes).

Local authorities having jurisdiction should be consulted before installation is made. Such applicable regulations or requirements take precedence over the general instructions in this manual.

Install the conditioned air plenum, ducts and air filters (provided) in accordance with NFPA 90B Standard for the Installation of Warm Air Heating and Air-Conditioning Systems (latest edition).

The air handler is shipped from the factory completely assembled. The unit is provided with flanges for the connection of the duct system.

Do not remove the cabinet knockouts until it has been determined which knockouts will need to be removed for the installation.

Select the air discharge position which best suits the site conditions. Consider required clearances, space, routing requirements for refrigerant line, condensate disposal, filters, duct system, wiring, and accessibility for service. Refer to the rating plate on the air handler for specific information.

⚠ WARNING



Danger of explosion. Keep flammable materials and vapors, such as gasoline, away from air handler. Place air handler so that heating elements are at least 18 inches (46 cm) above the floor for a garage installation. Failure to follow these instructions can result in death, explosion, or fire.

⚠ IMPORTANT

Excessive condensation may occur if the unit is installed in a warm, humid place. When the unit is installed in an unconditioned space, apply sealant around electrical wires, refrigerant piping and condensate lines at the point where they enter the cabinet.

Apply sealant on the inside of the cabinet at the point where the electrical wires exit through the conduit opening. This will also keep warm and moist unconditioned air out of the air handler cabinet where it will form condensate on the cooler control box and electrical controls.

NOTES –

During cooling operation, excessive sweating may occur if the air handler is installed in a warm and humid space.

If installed in an unconditioned space, sealant should be applied around the electrical wires, refrigerant tubing, and condensate lines where they enter the cabinet.

Electrical wires should be sealed on the inside where they exit the conduit opening. Sealant is required to prevent air leakage into, and condensate from forming inside of, the air handler, the control box, and on the electrical controls.

This unit is approved for installation clearance to combustible material as stated on the unit rating plate. Accessibility and service clearances must take precedence over combustible material clearances.

The air handler must be installed so that free access is allowed to the coil/filter compartment and blower/control compartment.

Unit Dimensions – Inches (mm)

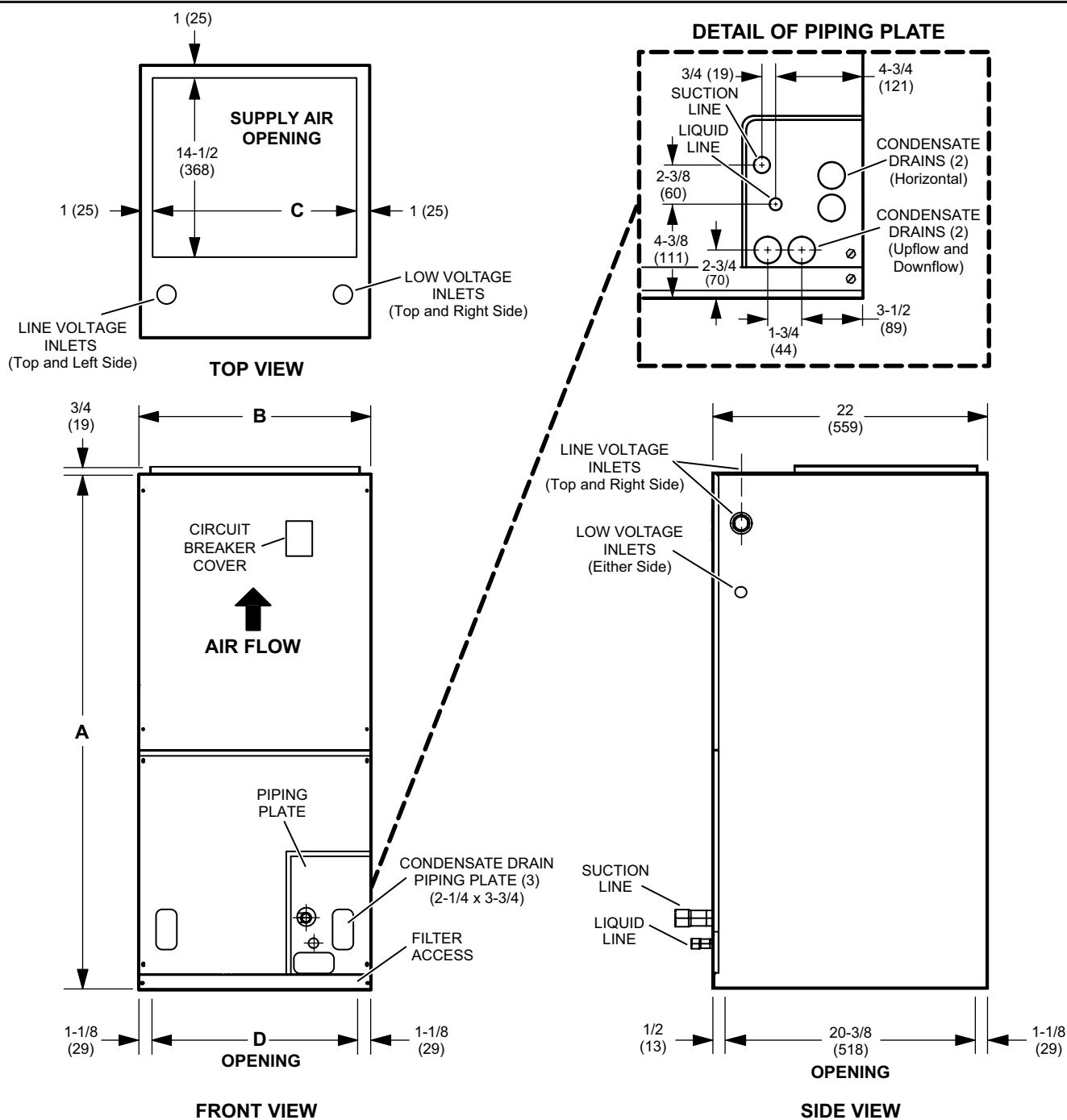

NOTE – Unit is shipped configured for horizontal right-hand air discharge. Unit may be converted to horizontal left-hand air discharge by repositioning horizontal drain pan.

Dimensions	018		024		030		036, 042		048		060	
	in.	mm	in.	mm	in.	mm	in.	mm	in.	mm	in.	mm
A	43-1/2	1105	45-1/2	1156	47	1194	53-5/8	1362	55	1397	59-3/4	1518
B	18-1/2	470	18-1/2	470	18-1/2	470	21-1/2	546	21-1/2	546	21-1/2	546
C	16-1/2	419	16-1/2	419	16-1/2	419	19-1/2	495	19-1/2	495	19-1/2	495
D	16-1/4	413	16-1/4	413	16-1/4	413	19-1/4	489	19-1/4	489	19-1/4	489

Unit Dimensions – Inches (mm)

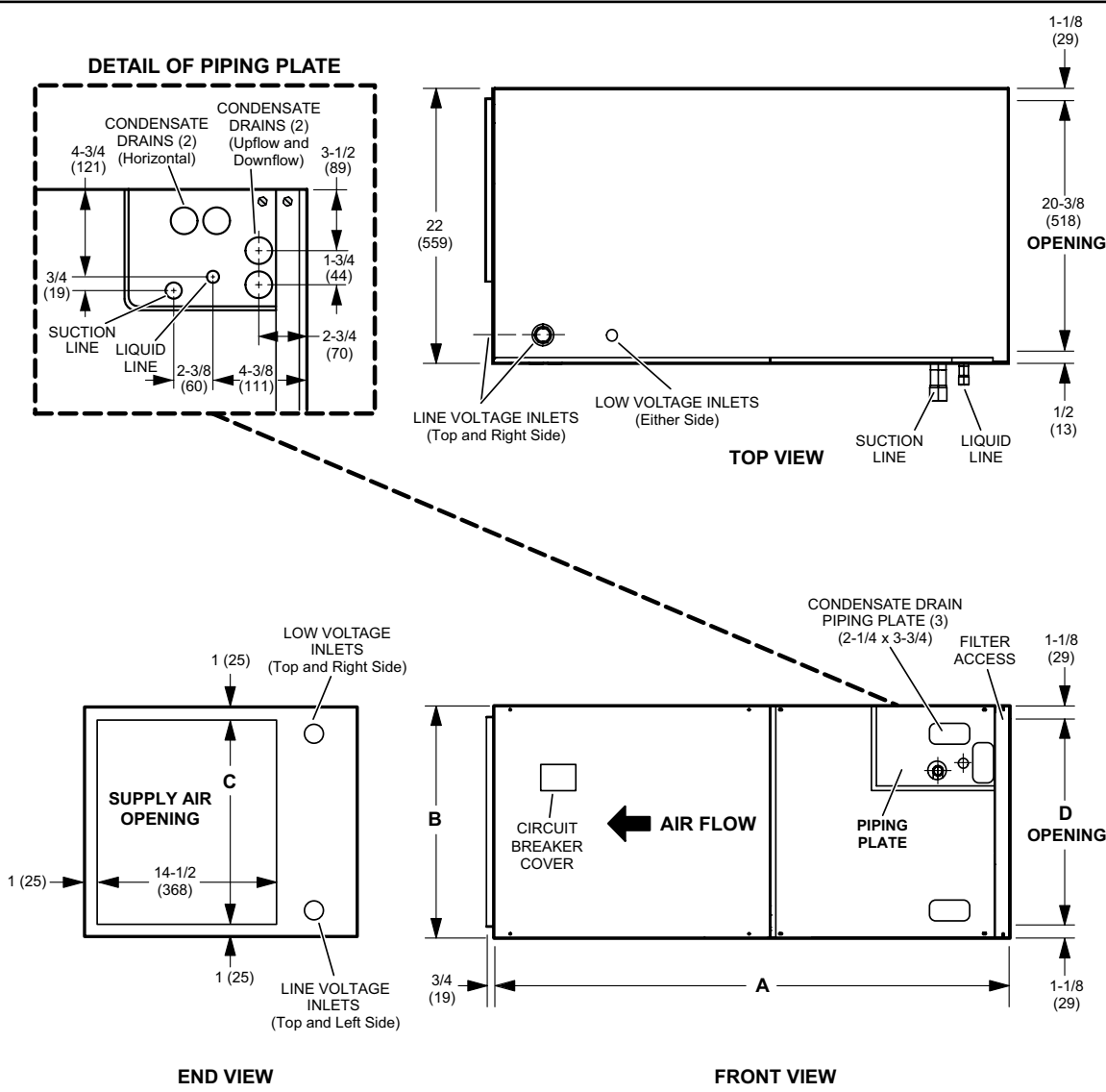

Dimensions	018		024		030		036, 042		048		060	
	in.	mm	in.	mm	in.	mm	in.	mm	in.	mm	in.	mm
A	43-1/2	1105	45-1/2	1156	47	1194	53-5/8	1362	55	1397	59-3/4	1518
B	18-1/2	470	18-1/2	470	18-1/2	470	21-1/2	546	21-1/2	546	21-1/2	546
C	16-1/2	419	16-1/2	419	16-1/2	419	19-1/2	495	19-1/2	495	19-1/2	495
D	16-1/4	413	16-1/4	413	16-1/4	413	19-1/4	489	19-1/4	489	19-1/4	489

⚠ WARNING

To prevent serious injury or death:

1. Lock-out/tag-out before performing maintenance.
2. If system power is required (e.g., smoke detector maintenance), disable power to blower, remove fan belt where applicable, and ensure all controllers and thermostats are set to the "OFF" position before performing maintenance.
3. Always keep hands, hair, clothing, jewelry, tools, etc. away from moving parts.

⚠ CAUTION

As with any mechanical equipment, contact with sharp sheet metal edges can result in personal injury. Take care while handling this equipment and wear gloves and protective clothing.

Installation Clearances

NON-DUCTED RETURN CLOSET INSTALLATION

The air handler can be installed in a closet with a false bottom to form a return air plenum. It may also be installed with a return air plenum under the air handler.

Louvers or return air grilles are field-supplied. Local codes may limit application of systems without a ducted return to single-story buildings.

When a 7AH1AV unit is installed in a closet with a louvered return opening, the minimum open area for the louvers will be:

- 320 square inches for -018 and -024 models;
- 360 square inches for -030 and -036 models;
- 450 square inches for -042 thru -060 models

If the free area is not known, assume a 25% free area for wood or a 75% free area for metal louvers or grilles. Using the louver dimensions and the 25% or 75% assumption, determine if the open area meets the minimum open area listed above.

If a return air plenum is used, the return air grille should be immediately in front of the opening in the plenum to allow for the free flow of return air. When not installed in front of the opening, there must be adequate clearance around the air handler to allow for the free flow of return air.

Installation

Every working procedure that affects safety means shall only be carried out by competent persons. This appliance is not to be used by persons (including children) with reduced physical, sensory or mental capabilities, or lack of experience and knowledge, unless they have been given supervision or instruction concerning use of the appliance by a person responsible for their safety. Examples of such working procedures are breaking into the refrigerating circuit, opening of sealed components, and opening of ventilated enclosures.

- Work shall be undertaken under a controlled procedure so as to minimize the risk of a flammable gas or vapor being present while the work is being performed.
- The area shall be checked with an appropriate refrigerant detector prior to and during work, to ensure the technician is aware of potentially toxic or flammable atmospheres. Ensure that the leak detection equipment being used is suitable for use with all applicable refrigerants, i. e. non-sparking, adequately sealed or intrinsically safe.
- If any hot work is to be conducted on the refrigerating equipment or any associated parts, the appropriate fire extinguishing equipment shall be available to hand. Have a dry powder or CO2 fire extinguisher adjacent to the charging area.
- No person carrying out work in relation to a refrigerating system which involves exposing any pipe work shall use any sources of ignition in such a manner that it may lead to the risk of fire or explosion. All possible ignition sources, including cigarette smoking, should be kept sufficiently far away from the site of installation, repairing, removing and disposal, during which refrigerant can possibly be released to the surrounding space. Prior to work taking place, the area around the equipment is to be surveyed to make sure that there are no flammable hazards or ignition risks. "No Smoking" signs shall be displayed.
- Ensure that the area is in the open or that it is adequately ventilated before breaking into the system or conducting any hot work. A degree of ventilation shall continue during the period that the work is carried out. Ventilation should disperse any released refrigerant. When possible, expel refrigerant directly into the atmosphere.
- Pipe-work including piping material, pipe routing, and installation shall include protection from physical damage in operation and service, and be in compliance with national and local codes and standards
- All field joints shall be accessible for inspection prior to being covered or enclosed
- Where electrical components are being changed, they shall be fit for the purpose and to the correct specification. At all times the manufacturer's maintenance and service guidelines shall be followed. If in doubt, consult the manufacturer's technical department for assistance. The following checks shall be applied to installations using FLAMMABLE REFRIGERANTS as applicable:
 1. The actual refrigerant charge is in accordance with the room size within which the refrigerant containing parts are installed.
 2. The ventilation machinery and outlets are operating adequately and are not obstructed.
 3. If an indirect refrigerating circuit is being used, the secondary circuit shall be checked for the presence of refrigerant.
 4. Markings on the equipment should be visible and legible. Markings and signs that are illegible shall be corrected.

5. Refrigerating pipe or components are installed in a position where they are unlikely to be exposed to any substance which may corrode refrigerant containing components, unless the components are constructed of materials which are inherently resistant to being corroded or are suitably protected against being so corroded.

- For systems containing refrigerant, all repair and maintenance to electrical components shall include initial safety checks and component inspection procedures such as that capacitors are discharged in a safe manner to avoid possibility of sparking, that no live electrical components and wiring are exposed while charging, recovering, or purging the system, and that there is continuity of earth bonding. If a fault exists that could compromise safety, then no electrical supply shall be connected to the circuit until it is satisfactorily dealt with. If the fault cannot be corrected immediately but it is necessary to continue operation, an adequate temporary solution shall be used that is reported to the owner of the equipment, so all parties are advised.

NOTE – Sealed electrical components shall be replaced, not repaired.

NOTE – Intrinsically safe components must be replaced, not repaired.

NOTE – All maintenance staff and others working in the local area shall be instructed on the nature of work being carried out with work in confined spaces being avoided.

- Under no circumstances shall potential sources of ignition be used in the searching for or detection of refrigerant leaks. A halide torch (or any other detector using a naked flame) shall not be used. The following leak detection methods are deemed acceptable for all refrigerant systems. Electronic leak detectors may be used to detect refrigerant leaks but, in the case of flammable refrigerants, the sensitivity may not be adequate, or may need re-calibration. (Detection equipment shall be calibrated in a refrigerant-free area.) Ensure that the detector is not a potential source of ignition and is suitable for the refrigerant used. Leak detection equipment shall be set at a percentage of the LFL of the refrigerant and shall be calibrated to the refrigerant employed, and that 12.5 % refrigerant is confirmed. Leak detection fluids are also suitable for use with most refrigerants but the use of detergents containing chlorine shall be avoided as the chlorine may react with the refrigerant and corrode the copper pipe-work. If a leak is suspected, all naked flames shall be removed/extinguished. If a leakage of refrigerant is found which requires brazing, all of the refrigerant shall be recovered from the system, or isolated (by means of shut off valves) in a part of the system remote from the leak.
- When breaking into the refrigerant circuit to make repairs – or for any other purpose – conventional procedures shall be used. However, for flammable refrigerants it is important that best practice be followed

and, since flammability is a consideration, procedures such as safely remove refrigerant following local and national regulations, purging the circuit with inert gas, evacuating (optional for A2L), purging with inert gas (optional for A2L), or opening the circuit by cutting or brazing be adhered to. The refrigerant charge shall be recovered into the correct recovery cylinders if venting is not allowed by local and national codes. For appliances containing flammable refrigerants, the system shall be purged with oxygen-free nitrogen to render the appliance safe for flammable refrigerants. This process might need to be repeated several times. Compressed air or oxygen shall not be used for purging refrigerant systems. For appliances containing flammable refrigerants, refrigerants purging shall be achieved by breaking the vacuum in the system with oxygen-free nitrogen and continuing to fill until the working pressure is achieved, then venting to atmosphere, and finally pulling down to a vacuum (optional for A2L). This process shall be repeated until no refrigerant is within the system (optional for A2L). When the final oxygen-free nitrogen charge is used, the system shall be vented down to atmospheric pressure to be able to perform the required work. Ensure that the outlet for the vacuum pump is not close to any potential ignition sources and working area is well ventilated.

Each unit consists of a blower assembly, refrigerant coil, and controls in an insulated galvanized steel factory-finished enclosure. Knockouts are provided for electrical wiring entrance.

For ease in installation, it is best to make any necessary coil configuration changes before setting air handler in place.

REFRIGERANT METERING DEVICE

7AH1AV units are equipped with a factory-installed check/expansion valve.

UPFLOW APPLICATION

- 1 - The air handler must be supported on the bottom only and set on solid floor or field-supplied support frame. Securely attach the air handler to the floor or support frame.
- 2 - If installing a unit in an upflow application, remove the horizontal drain pan. **IMPORTANT - The horizontal drain pan is not required in upflow air discharge installations; its removal provides the best efficiency and air flow.**
- 3 - Place the unit in the desired location and slope unit. Connect return and supply air plenums as required using sheet metal screws.
- 4 - Install units that have no return air plenum on a stand that is at least 14" from the floor. This will allow proper air return.

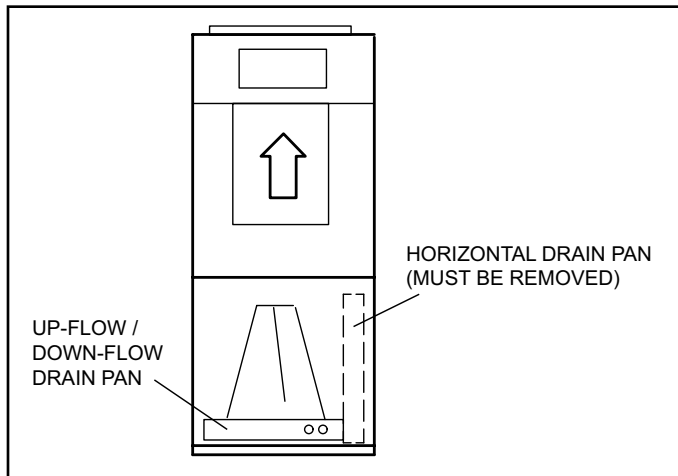

FIGURE 4. Upflow Configuration

HORIZONTAL APPLICATIONS

▲ IMPORTANT

When removing the coil, there is a possibility of danger of equipment damage and personal injury. Be careful when removing the coil assembly from a unit installed in right- or left-hand applications. The coil may tip into the drain pan once it is clear of the cabinet. Support the coil when removing it..

NOTE - When the unit is installed in horizontal applications, a secondary drain pan is recommended. Refer to local codes.

NOTE - This unit may be installed in left-hand or right-hand air discharge horizontal applications. Adequate support must be provided to ensure cabinet integrity. Ensure that there is adequate room to remove service and access panels if installing in the horizontal position.

RIGHT-HAND DISCHARGE

- 1 - Determine which plugs are required for drain line connections.
- 2 - With access door removed, remove drain line plugs to install drain lines.
- 3 - Set unit so that it is sloped toward the upflow drain pan end of the unit and level from front to back of unit (see figure 14).
- 4 - The horizontal configuration is shown in figure 5.

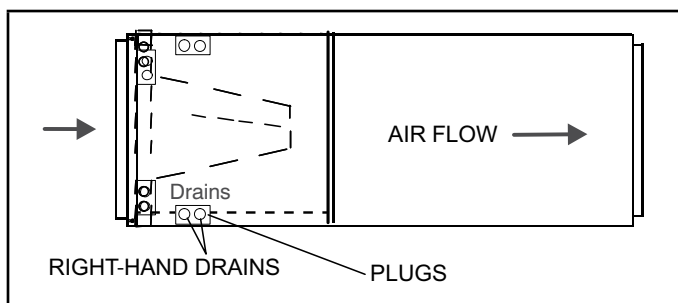

FIGURE 5. Right-Hand Discharge Configuration

- 5 - If the unit is suspended, the entire length of the cabinet must be supported. If you use a chain or strap, use a piece of angle iron or sheet metal attached to the unit (either above or below) to support the length of the cabinet. Use securing screws no longer than 1/2 inch to avoid damaging the coil or filter. See figure 6. Use sheet metal screws to connect the return and supply air plenums as required.

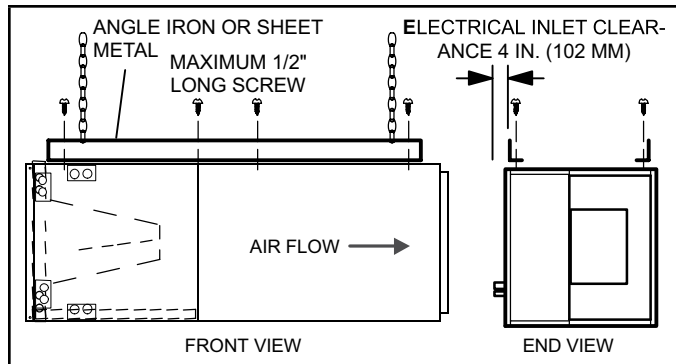

FIGURE 6. Suspending Horizontal Unit

LEFT-HAND AIR DISCHARGE

For horizontal left-hand air discharge, the following field modifications are required.

- 1 - Remove access panels and the corrugated padding between the blower and coil assembly. Discard the corrugated padding.
- 2 - Pull the coil assembly from unit. Pull off the horizontal drain pan.
- 3 - Remove the drain plugs from back drain holes on horizontal drain pan and reinstall them on front holes.

▲ IMPORTANT

After removal of drain pan plug(s), check drain hole(s) to verify that drain opening is fully open and free of any debris. Also check to make sure that no debris has fallen into the drain pan during installation that may plug up the drain opening.

- 4 - Rotate drain pan 180° front-to-back and install it on the opposite side of the coil.
- 5 - Remove screws from top cap.
- 6 - Remove plastic plug from left hole on coil front end seal and reinstall plug in back hole.

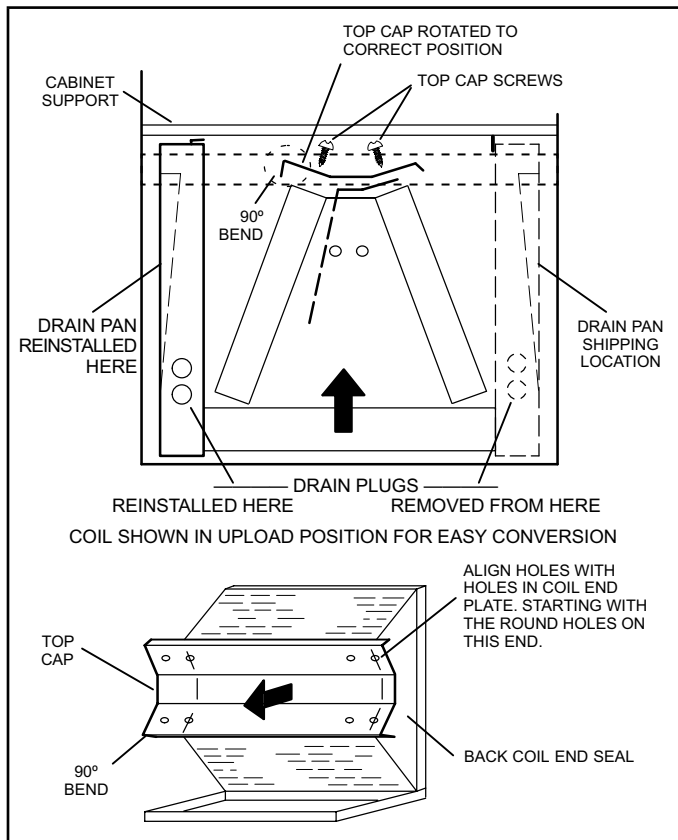

FIGURE 7. Field Modification for Left-Hand Discharge

- 7 - Rotate top cap 180° front-to-back and align with unused screw holes. Holes must align with front and back coil end plates. The top cap has a 45° bend on one side and a 90° bend on the other. **The 90° bend must be on the same side as the horizontal drain pan as illustrated in figure 7.**

NOTE – Be very careful when reinstalling the screws into the coil end plate engaging holes. Misaligned screws may damage the coil.

- 8 - From the upflow position, flip cabinet 90° to the left and set into place. Replace blower assembly. Secure coil in place by bending down the tab on the cabinet support rail as illustrated.

NOTE – Seal around the exiting drain pipe, liquid and suction lines to prevent infiltration of humid air.

- 9 - Flip access door and replace it on the unit.
- 10 - Set unit so that it is sloped 1/4" toward the drain pan end of the unit. Connect return and supply air plenums as required using sheet metal screws.

- 11 - If suspending the unit, it must be supported along the entire length of the cabinet. If using chain or strap, use a piece of angle iron or sheet metal attached to the unit (either above or below) so that the full length of the cabinet is supported. Use securing screws no longer than 1/2" to avoid damage to coil or filter, as illustrated in figure 6. Connect return and supply air plenums as required using sheet metal screws.

DOWNFLOW APPLICATION

NOTE – If downflow application is required, separately order kit number Y9658 (-018 through -030) or Y9659 (-036 through -060) and install per kit's instructions. Also use metal or class I supply and return air plenums.

Use the installation instruction provided with the downflow kit.

⚠ IMPORTANT

If electric heat section with circuit breakers (ECB45) is installed in a 7AH1AV unit in a downflow application, the circuit breakers must be rotated 180° to the UP position. See ECB45 installation instructions for more details.

Sensor / Bracket Installation

Vertical Configuration

Leak detection sensor and bracket are factory-installed for vertical installation. No sensor relocation is required if installing in vertical configuration.

NOTE – The leak detection sensor needs to be relocated for horizontal right, horizontal left, and downflow configurations.

Horizontal Right Configuration

- 1 - Remove sensor bracket assembly from vertical position (shown in figure 8). Do not remove sensor from bracket, and do not disconnect or reroute sensor wire from the control panel area.



FIGURE 8

- 2 - Follow instructions for right-hand discharge as outlined in previous section on page 16.

- 3 - With air handler unit panels removed, install sensor bracket assembly to the unit by lining up holes in the center support bracket as shown in figure 10. Note: sensor should be facing toward the inside of the unit.

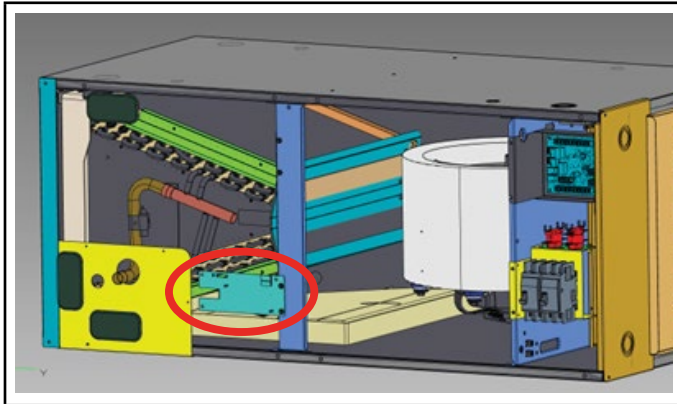

FIGURE 9

- 4 - Ensure sensor wire routes to the right hand side, as viewed from the front of the unit. The wire must route through the slotted opening in the center support bracket (see figure 9).

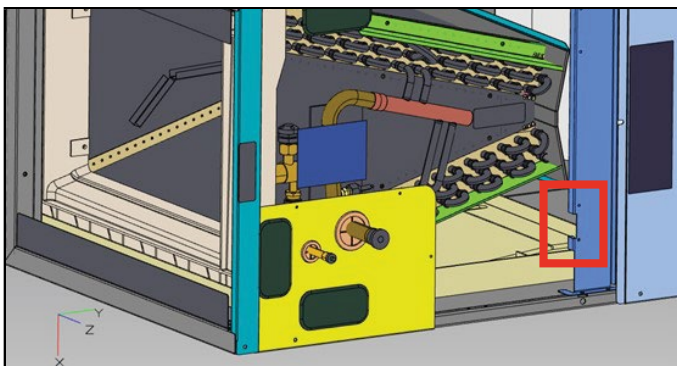

FIGURE 10

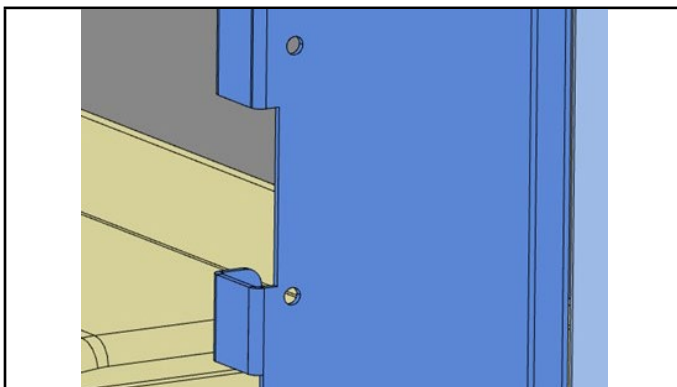

FIGURE 10 (Detail)

- 5 - Loop any excess wire through the plastic "M" wire clip located on the inside of the center support bracket.

Horizontal Left Configuration

- 1 - Remove sensor bracket assembly from vertical position. Do not remove sensor from bracket, and do not disconnect or reroute sensor wire from the control panel area. Set the sensor bracket assembly aside.
- 2 - Follow instructions for left-hand discharge as outlined in previous section on pages 16 and 17. Instructions are also located on sticker on top of coil assembly.
- 3 - After coil assembly and center support bracket are reinstalled into unit, with air handler unit panels removed, install sensor bracket assembly to the center support bracket by lining up the holes as shown in figure 11.

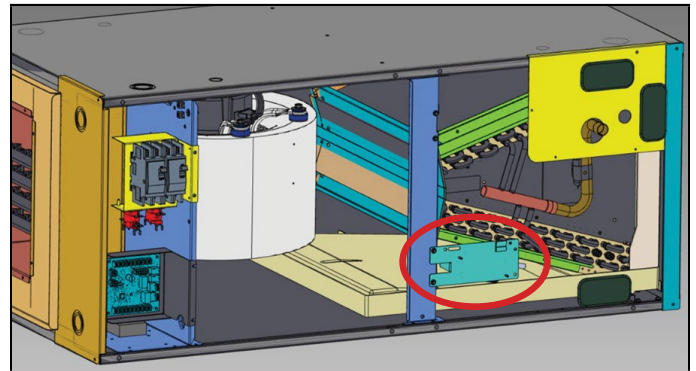

FIGURE 11

- 4 - Loop any excess wire through the plastic "M" wire clip located on the inside of the center support bracket.

Downflow Configuration

- 1 - Remove sensor bracket assembly from vertical position. Do not remove sensor from bracket, and do not disconnect or reroute sensor wire from the control panel area. Set the sensor bracket assembly aside.
- 2 - Follow the downflow conversion installation instructions located in the downflow installation kit (ordered separately).

NOTE – Refer to the downflow kit installation instructions for more details on unit configuration.

- 3 - With air handler access panels removed, install sensor bracket assembly to the side of the cabinet by lining up holes as shown in figure 12.

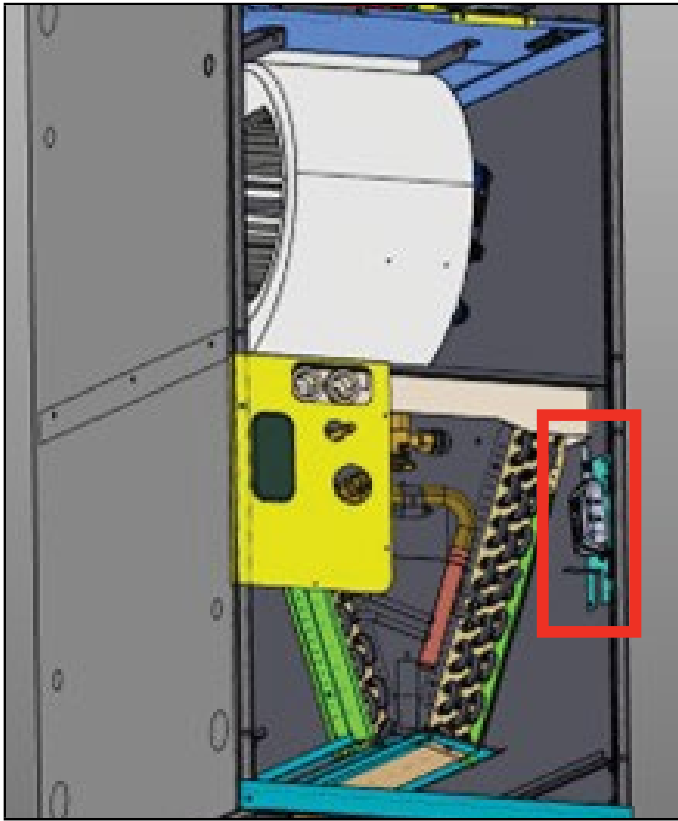

FIGURE 12

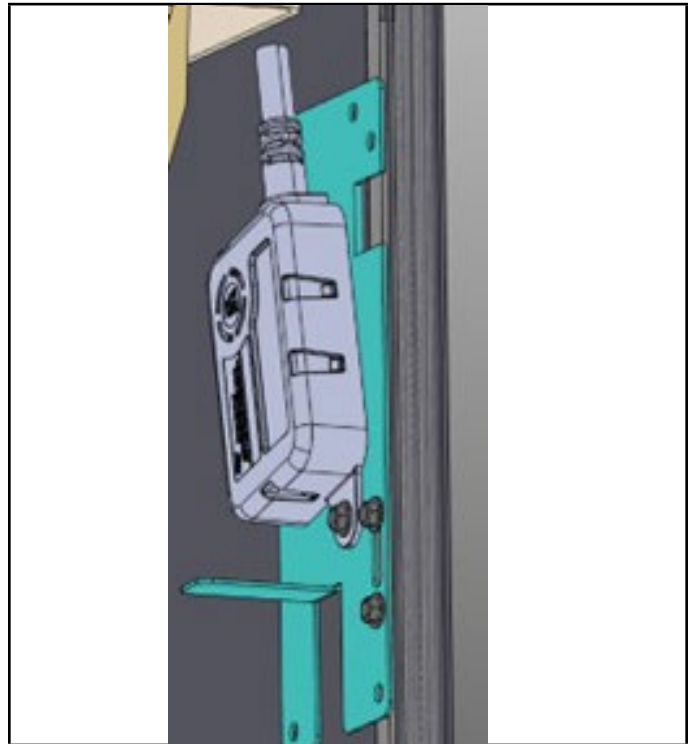

FIGURE 12 (Detail)

4 - Loop and bundle any excess sensor wire with a wire tie.

Condensate Drain

⚠ IMPORTANT

On units of this type, where the blower “draws” rather than “blows” air through the coil, traps must be installed in the condensate drain lines (primary and auxiliary, if used). Traps prevent the blower from drawing air through the drain lines into the air supply.

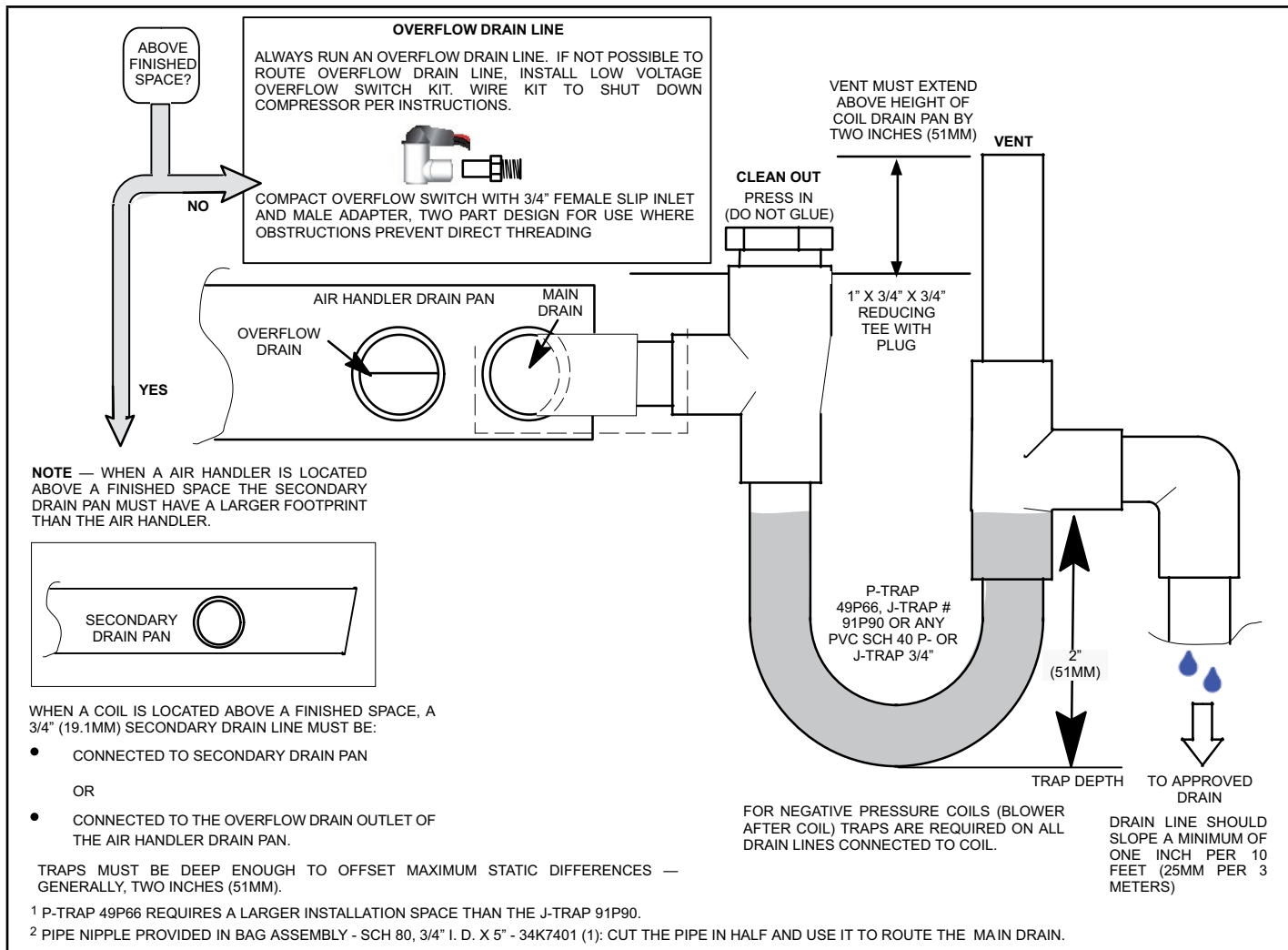

FIGURE 13. Typical Main and Overflow Drain

⚠ IMPORTANT

A field-fabricated secondary drain pan, with a drain pipe to the outside of the building, is required in all installations over a finished living space or in any area that may be damaged by overflow from the main drain pan. In some localities, local codes may require a secondary drain pan for any horizontal installation.

SLOPING THE UNIT

Make sure the unit is sloped (similar to the slope shown in figure 14) so that the drain pan will empty completely without water standing in the pan.

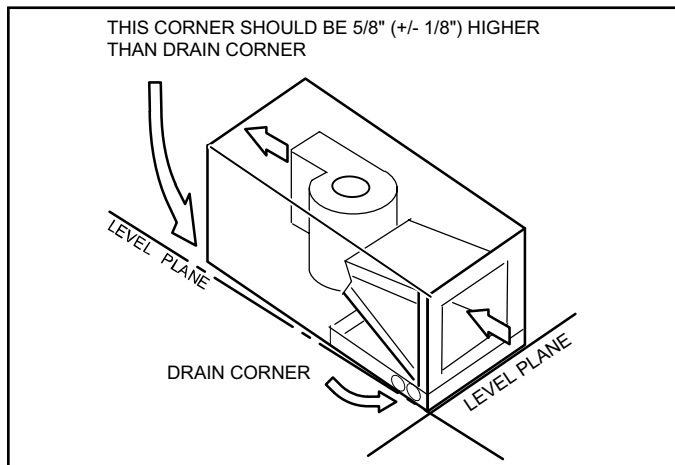

FIGURE 14. Sloping the Unit for Proper Drainage

INSTALL CONDENSATE DRAIN

The air handler is provided with 3/4" NPT condensate drain connections.

▲ IMPORTANT

Confirm primary and secondary drains are open.

- 1 - 7AH1AV units are equipped with a drain pan, which includes green (main drain) and red (secondary drain) plugs. Unscrew the plugs to remove them before inserting condensate drain fittings.

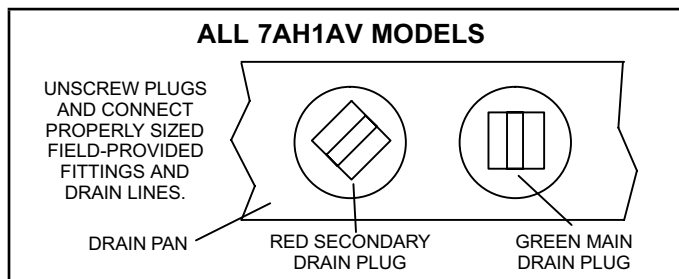

FIGURE 15. Drain Line Connections

- 2 - Install properly sized, field-provided connection fittings and connect primary drain line to the main drain pan connection.

NOTE - When installing drain line connection fittings to the drain pan, hand tighten the fitting and use a thread sealant. Over-tightening the fittings can split connections on the drain pan.

- 3 - If the secondary drain line is to be used, remove the plug or the knockout and route the drain line so that water draining from the outlet will be easily noticed by the homeowner. Refer to local codes for drain trap requirements on the secondary drain line.
- 4 - Check again to ensure drain ports and drain pan are free of all debris.
- 5 - Plug and check any unused drain pan openings for tightness. Torque plugs to 36 in. lb. to prevent water leaks or seepage from the drain pan.
- 6 - Install a 2" trap in the main (primary) drain lines as close to the unit as practical (see figure 13). Make sure the top of the trap is below the connection to the drain pan to allow complete drainage of the pan.

NOTE - Horizontal runs must have an anti-siphon air vent (standpipe) installed ahead of the horizontal run. See figure 13. An extremely long horizontal run may require an oversized drain line to eliminate air traps.

NOTE - Do not operate air handler without a trap in the main (primary) drain. The condensate drain is on the negative pressure side of the blower; therefore, air being pulled through the condensate line will not allow positive drainage without a proper trap.

- 7 - Route the drain line to the outside or to an appropriate drain. Drain lines must be installed so they do not block service access to the front of the air handler. A 24" clearance is required for filter, coil, or blower removal and service access.

NOTE - Check local codes before connecting the drain line to an existing drainage system. Insulate the drain lines where sweating could cause water damage.

TEST CONDENSATE DRAIN

Test the drain pan and drain line after installation:

- 1 - Pour several quarts of water into drain pan. Use enough water to fill both the drain trap and the line.
- 2 - Check the installed drain pan. Drain pan must be draining completely. Drain line fittings must not be leaking. Water must be draining from the end of the primary drain line.
- 3 - Correct any leaks found.

Duct System and Filters

DUCT SYSTEM

The air handler is provided with flanges for the connection of the supply plenum.

Supply and return duct system must be adequately sized to meet the system's air requirements and static pressure capabilities. The duct system should be insulated with a minimum of 1" thick insulation with a vapor barrier in conditioned areas or 2" minimum in unconditioned areas.

Supply plenum should be the same size as the flanged opening provided around the blower outlet and should extend at least 3 ft. from the air handler before turning or branching off plenum into duct runs. The plenum forms an extension of the blower housing and minimizes air expansion losses from the blower.

FILTERS

A filter is provided. Table 11 lists the filter size for each unit.

TABLE 11. Unit Air Filter Size Chart

7AH1AV	Filter Size – In.
-018, -024, -030	15" x 20" x 1"
-036, -042, -048, -060	18" x 20" x 1"

▲ IMPORTANT

If a high efficiency filter is being installed as part of this system to ensure better indoor air quality, the filter must be properly sized. High efficiency filters have a higher static pressure drop than standard efficiency glass/foam filters. If the pressure drop is too great, system capacity and performance may be reduced. The pressure drop may also cause the limit to trip more frequently during the winter and the indoor coil to freeze in the summer, resulting in an increase in the number of service calls. Before using any filter with this system, check the specifications provided by the filter manufacturer against the data given in the appropriate Allied Specifications Sheet.

INSTALLING DUCT SYSTEM

Connect supply air duct to the flange on top of the air handler. If an isolation connector is used, it must be nonflammable.

FIELD-FABRICATED RETURN AIR DUCT FLANGE FOR HORIZONTAL APPLICATIONS

A return air duct system is recommended, but not factory-provided. If the unit is installed in a confined space or closet, run a full-size return connection to a location outside the closet.

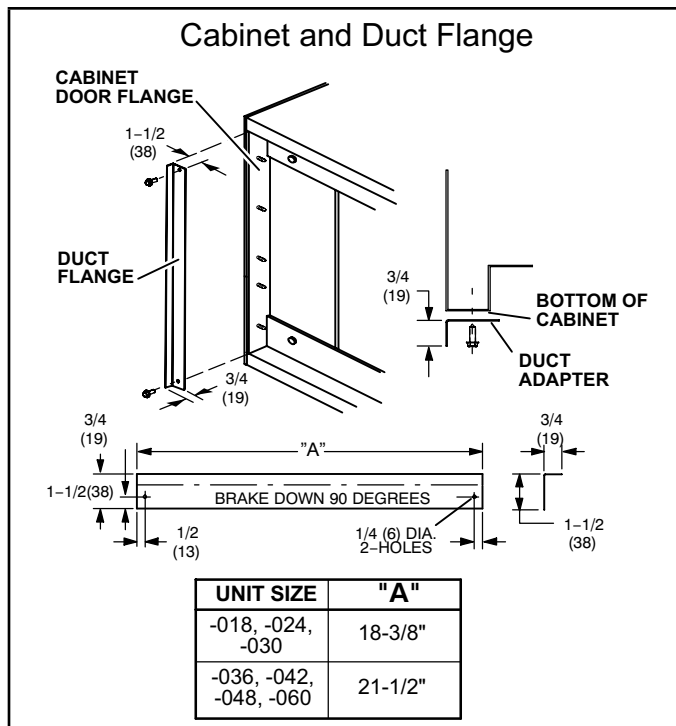

FIGURE 16. Cabinet and Duct Flange

Brazing Refrigerant Lines

⚠ IMPORTANT

Braze-free fittings must conform with UL207 or ISO14903 (latest edition).

Refrigerant lines must be connected by a qualified technician in accordance with established procedures.

Refrigerant lines must be connected by a qualified technician in accordance with established procedures.

⚠ IMPORTANT

Refrigerant lines must be clean, dry, refrigerant-grade copper lines. Air handler coils should be installed only with specified line sizes for approved system combinations.

Handle the refrigerant lines gently during the installation process. Sharp bends or kinks in the lines will cause a restriction.

Do not remove the caps from the lines or system connection points until connections are ready to be completed.

⚠ WARNING

Polyol ester (POE) oils used with R-454B refrigerant absorb moisture very quickly. It is very important that the refrigerant system be kept closed as much as possible. DO NOT remove line set caps or service valve stub caps until you are ready to make connections.

⚠ WARNING



Danger of fire. Bleeding the refrigerant charge from only the high side may result in pressurization of the low side shell and suction tubing. Application of a brazing torch to a pressurized system may result in ignition of the refrigerant and oil mixture. Check the high and low pressures before applying heat.

⚠ WARNING



When using a high pressure gas such as nitrogen to pressurize a refrigeration or air conditioning system, use a regulator that can control the pressure down to 1 or 2 psig (6.9 to 13.8 kPa).

⚠ CAUTION

Brazing alloys and flux contain materials which are hazardous to your health.

Avoid breathing vapors or fumes from brazing operations. Perform operations only in well-ventilated areas.

Wear gloves and protective goggles or face shield to protect against burns.

Wash hands with soap and water after handling brazing alloys and flux.

⚠ IMPORTANT

To prevent the build-up of high levels of nitrogen when purging, it must be done in a well-ventilated area. Purge low-pressure nitrogen (1 to 2 psig) through the refrigerant piping during brazing. This will help to prevent oxidation and the introduction of moisture into the system.

Refrigerant system installations shall be installed and tested per ASHRAE Standard 15.2, Section 10.0 (latest edition).

NOTE - When installing refrigerant lines longer than 50 feet, see the *Allied Refrigerant Piping Design and Fabrication Guidelines*, or contact *Allied Technical Support* for assistance. To obtain the correct information from Allied, be sure to communicate the following information: Model number and capacity.

- 1 - Route the suction and liquid lines from the fittings on the indoor coil to the fittings on the outdoor unit. Run the lines in a direct path, avoiding unnecessary turns and bends.
- 2 - Make sure that the suction line is insulated over the

entire exposed length and that neither suction nor liquid lines are in direct contact with floors, walls, duct system, floor joists, or other piping.

- 3 - To avoid damaging the rubber grommets in the cabinet while brazing, slide the rubber grommets over the refrigerant lines until they are away from the heat source.

NOTE - Place wet rags against piping plate, piping stubs and expansion valve.

- 4 - Connect the suction and liquid lines to the evaporator coil. Take care to protect the cabinet and internal components as detailed in figure 18.
- 5 - Braze using an alloy of silver or copper and phosphorus with a melting point above 1,100°F (593°C).

NOTE - Do not use soft solder.

- 6 - Allow refrigerant pipes to cool to room temperature.

NOTE - Make sure to route copper refrigerant tubing away from sharp edges and make sure that it does not touch other metal surfaces. This prevents damage caused by vibration or metal-on-metal contact.

- 7 - Reinstall the rubber grommets into the refrigerant piping panel.

NOTE - Make sure expansion valve capillary tube is not touching metal edges or copper tubing.

- 8 - Make sure outdoor unit has been placed according to the Installation Instructions and is connected to the refrigerant lines.

Multiple Systems Installed in Same Space

If multiple systems are installed in the same confined space, and at least one of the systems has A2L refrigerant and an exposed joint (not covered by line set sleeve), then all non-direct vent furnaces in the same space must have a refrigerant detection system with a sensor installed below the level of the burners. If refrigerant sensor is required, it shall be mounted as follows:

Upflow Applications: Mounted on an unused side furnace return air connection at least 9 inches above the floor and within 9 inches from front of furnace.

Horizontal Applications: Mounted on the lower section of the side return furnace air connection, within 9 inches of both the blower deck and front of furnace.

Downflow Applications: Mounted on one side of the evaporator coil 9 inches above the floor and within 9 inches from front of coil.

Braze-Free Applications

- 1 - Remove bell from the stubbed connection using a tubing cutter.
- 2 - Position the refrigerant piping and follow the assembly instructions provided with the braze free connector.

IMPORTANT

After completion of field piping for split systems, the field pipework shall be pressure tested with an inert gas and then vacuum tested prior to refrigerant charging, according to the following requirements;

– Field-made refrigerant joints indoors shall be tightness tested. The test method shall have a sensitivity of 5 grams per year of refrigerant or better under a pressure of at least 0,25 times the maximum allowable pressure marked on unit nameplate.

No leak shall be detected.

PLEASE READ IMPORTANT ISSUES CONCERNING BRAZING OPERATIONS ON PREVIOUS PAGES BEFORE PROCEEDING.

NOTE - REFER TO OUTDOOR UNIT INSTALLATION INSTRUCTIONS FOR REFRIGERANT PIPING SIZE REQUIREMENTS.

NOTE - Use silver alloy brazing rods with five or six percent minimum silver alloy for copper-to-copper brazing, 45 percent alloy for copper-to-brass and copper-to-steel brazing.

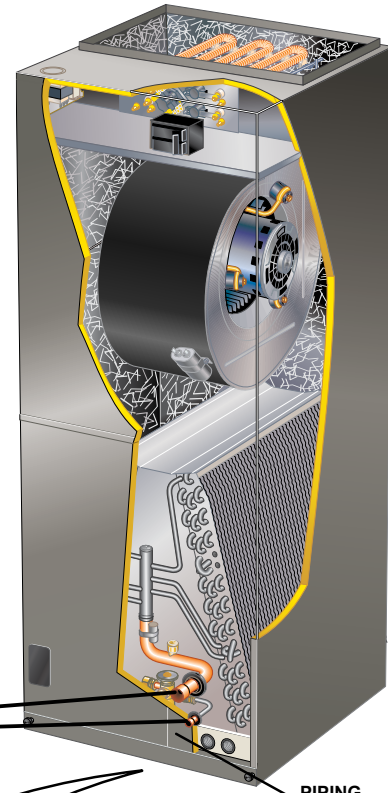

A REMOVE ACCESS PANEL

B REMOVE RUBBER PLUG FROM BOTH LIQUID AND SUCTION LINES

NOTE - 7AH1AV SERIES UNITS USE NITROGEN OR DRY AIR AS A HOLDING CHARGE. IF THERE IS NO PRESSURE WHEN THE RUBBER PLUGS ARE REMOVED, CHECK THE COIL FOR LEAKS BEFORE INSTALLING.

C EITHER REMOVE OR PUSH PIPE WRAPPING BACK THROUGH HOLE IN PIPING PLATE BEFORE LINE SET CONNECTION AND BRAZING.

D CONNECT PIPES

NOTE - REFRIGERANT LINE SETS SHOULD BE ROUTED TO ALLOW FILTER ACCESSIBILITY.

E CONNECT GAUGES AND START NITROGEN FLOW

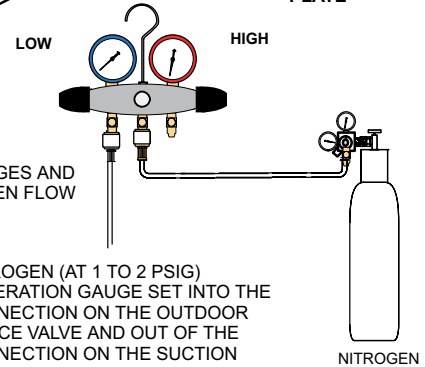

FLOW REGULATED NITROGEN (AT 1 TO 2 PSIG) THROUGH THE REFRIGERATION GAUGE SET INTO THE VALVE STEM PORT CONNECTION ON THE OUTDOOR UNIT LIQUID LINE SERVICE VALVE AND OUT OF THE VALVE STEM PORT CONNECTION ON THE SUCTION SERVICE VALVE.

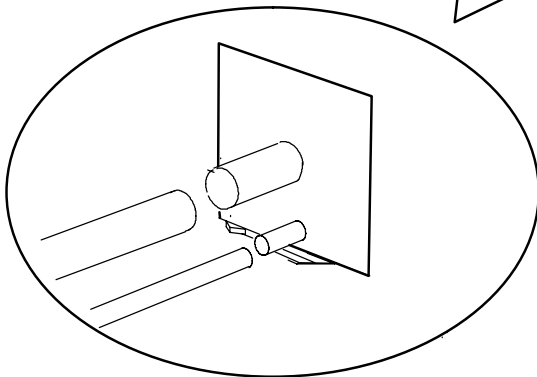

F PLACE A WET RAG AGAINST PIPING PLATE AND AROUND THE SUCTION LINE CONNECTION.

G BRAZE CONNECTION. ALLOW PIPE TO COOL BEFORE REMOVING WET RAG FROM CTXV SENSING BULB AND PIPING PANEL AREA.

H REPEAT PREVIOUS PROCEDURE FOR LIQUID LINE.

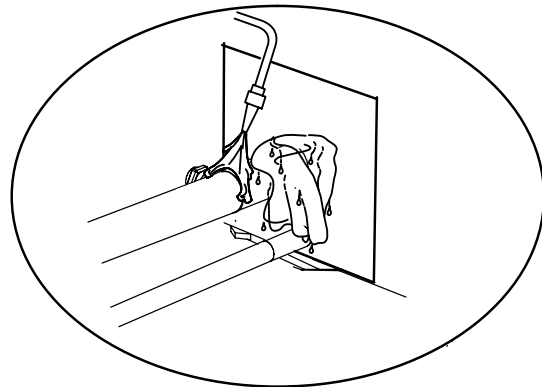

REFER TO INSTRUCTIONS PROVIDED WITH OUTDOOR UNIT FOR LEAK TESTING, EVACUATING AND CHARGING PROCEDURES. REFRIGERANT SYSTEM INSTALLATIONS SHALL BE INSTALLED AND TESTED PER ASHRAE STANDARD 15.2, SECTION 10.0 (LATEST EDITION).

FIGURE 17. Brazing Connections

Sealing the Unit

Seal the unit so that warm air is not allowed into the cabinet. Warm air introduces moisture, which results in water blow-off problems. This is especially important when the unit is installed in an unconditioned area.

If installed in an unconditioned space, sealant should be applied around the electrical wires, refrigerant tubing, and condensate lines where they enter the cabinet.

WARNING

There must be an airtight seal between the bottom of the air handler and the return air plenum. Use fiberglass sealing strips, caulking, or equivalent sealing method between the plenum and the air handler cabinet to ensure a tight seal. Return air must not be drawn from a room where this air handler or any gas-fueled appliance (i.e., water heater), or carbon monoxide-producing device (i.e., wood fireplace) is installed.

IMPORTANT

Use duct tape and/ or Permagum to seal closed any space around the holes where the drain lines exit the cabinet. Warm air must not be allowed to enter through any gaps or holes in the cabinet.

Electrical Connections

WARNING

 Electric shock hazard! - Disconnect all power supplies before servicing.
Replace all parts and panels before operating.
Failure to do so can result in death or electrical shock.

WARNING

Run 24V Class II wiring only through specified low voltage opening. Run line voltage wiring only through specified high voltage opening. Do not combine voltage in one opening.

WARNING

 Electric Shock Hazard. Can cause injury or death. Unit must be properly grounded in accordance with national and local codes.
Line voltage is present at all components when unit is not in operation on units with single-pole contactors. Disconnect all remote electric power supplies before opening access panel. Unit may have multiple power supplies.

WARNING

 Electric Shock Hazard.
Can cause injury or death.
Foil-faced insulation has conductive characteristics similar to metal. Be sure there are no electrical connections within 1/2" of the insulation. If the foil-faced insulation comes in contact with electrical voltage, the foil could provide a path for current to pass through to the outer metal cabinet. While the current produced may not be enough to trip existing electrical safety devices (e.g., fuses or circuit breakers), the current can be enough to cause an electrical shock hazard that could cause personal injury or death.

- Wiring must conform to the current National Electric Code ANSI/NFPA No. 70, or Canadian Electric Code Part I, CSA Standard C22.1, and local building codes. Refer to following wiring diagrams. See unit nameplate for minimum circuit ampacity and maximum over-current protection size.
- Electrical wiring, disconnect means and over-current protection are to be supplied by the installer. Refer to the air handler rating plate for maximum over-current protection, minimum circuit ampacity, as well as operating voltage. Select the proper supply circuit conductors in accordance with tables 310-16 and 310-17 in the National Electric Code, ANSI/NFPA No. 70 or tables 1 through 4 in the Canadian Electric Code, Part I, CSA Standard C22.1.
- The power supply must be sized and protected according to the specifications supplied on the product.
- This air handler is factory-configured for 240 volt, single phase, 60 cycles. For 208-volt applications, see "208 Volt Conversion" later in this section.
- Separate openings have been provided for 24V low voltage and line voltage. Refer to the dimension illustration of specific location.
- This unit is provided with holes for conduit. Use provided caps to seal holes not used.
- Typical unit wiring (as well as wiring of optional field-installed electric heat) is given in figure 30. Refer to the instructions provided with the electric heat section for proper installation.

WARNING

USE COPPER CONDUCTORS ONLY

- 1 - Disconnect all power supplies.
- 2 - Remove the air handler access panel.
- 3 - Route the field supply wires to the air handler electrical connection box.

- 4 - Use UL-listed wire nuts to connect the field supply conductors to the unit black and yellow leads, and the ground wire to ground terminal marked GND.
- 5 - Replace the air handler access panel.

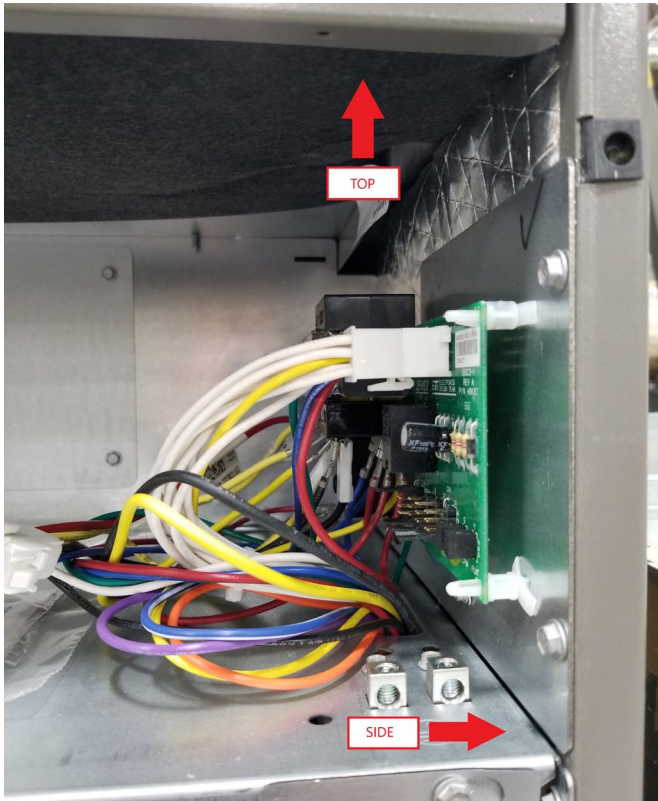

FIGURE 18. Electrical Connections (Upflow Configuration)

NOTE - To avoid the possibility of moisture damage to the control in some right-hand discharge configurations, re-locate control bracket to the pre-drilled holes in the top panel as shown in figure 20.

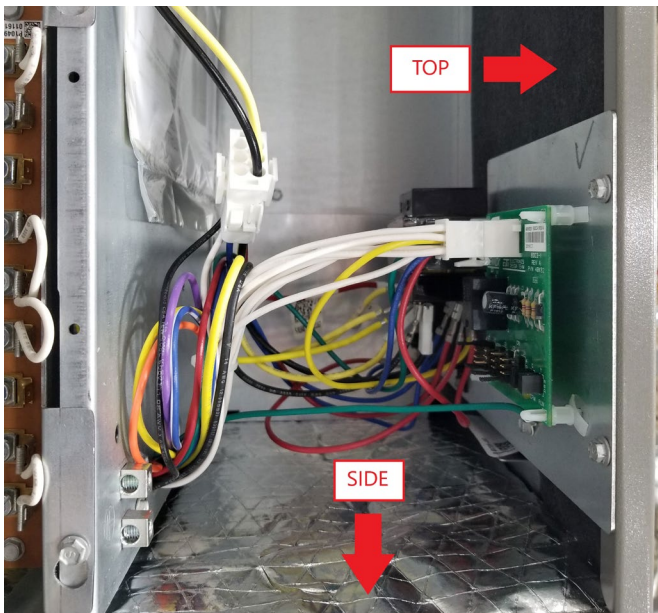

FIGURE 19. Control Panel Relocated to End Panel (Right-Hand Horizontal Configuration)

208 VOLT CONVERSION

- 1 - Disconnect all power supplies.
- 2 - Remove the air handler access panel.
- 3 - Using the wiring diagram located on the unit access panel as a reference, move the 2 connected black transformer leads from the 240 volt terminal on the transformer to the 208 volt terminal on the transformer.

⚠ WARNING	
	Electrically ground air handler. Connect ground wire to ground terminal marked "GND".
	Failure to do so can result in death or electrical shock.

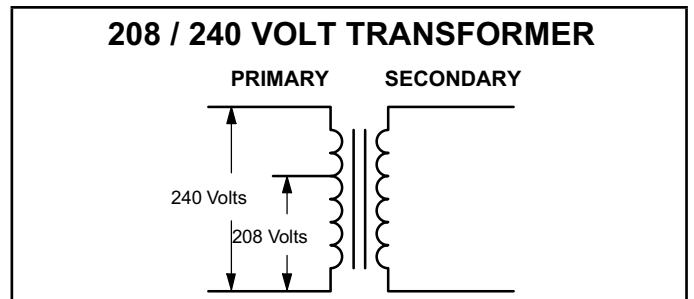

FIGURE 20. Converting Unit from 240VAC to 208VAC

⚠ IMPORTANT	
This unit is approved for installation clearance to combustible material as stated on the unit rating plate. Accessibility and service clearances must take precedence over combustible material clearances.	
The air handler must be installed so that free access is allowed to the coil/filter compartment and blower/control compartment.	

Check-out Procedures

NOTE - Refer to outdoor unit installation instructions for system start-up instructions and refrigerant charging instructions.

PRE-START-UP CHECKS

- Is the air handler properly and securely installed?
- If horizontally configured, is the unit sloped up to 5/8 inch toward drain lines?
- Will the unit be accessible for servicing?
- Has an auxiliary pan been provided under the unit with separate drain for units installed above a finished ceiling or in any installation where condensate overflow could cause damage?
- Have ALL unused drain pan ports been properly plugged?
- Has the condensate line been properly sized, run, trapped, pitched, and tested?
- Is the duct system correctly sized, run, sealed, and insulated?
- Have all cabinet openings and wiring been sealed?

- Is the indoor coil factory-installed TXV properly sized for the outdoor unit being used?
- Have all unused parts and packaging been disposed of?
- Is the filter clean, in place, and of adequate size?
- Is the wiring neat, correct, and in accordance with the wiring diagram?
- Is the unit properly grounded and protected (fused)?
- Is the thermostat correctly wired and in a good location?
- Are all access panels in place and secure?

CHECK BLOWER OPERATION

- Set thermostat to FAN ON.
- The indoor blower should come on.

CHECK COOLING OPERATION

- Set thermostat to force a call for cooling (approximately 5°F lower than the indoor ambient temperature).
- The outdoor unit should come on immediately and the indoor blower should start between 30 - 60 seconds later.
- Check the air flow from a register to confirm that the system is moving cooled air.
- Set the thermostat 5°F higher than the indoor temperature. The indoor blower and outdoor unit should cycle off.

CHECK ELECTRIC HEAT (IF USED)

- Set thermostat to call for auxiliary heat (approximately 5°F above ambient temperature). The indoor blower and auxiliary heat should come on together. Allow a minimum of 3 minutes for all sequencers to cycle on.
- Set the thermostat so that it does not call for heat. Allow up to 5 minutes for all sequencers to cycle off.

Maintenance

⚠ IMPORTANT

Do not operate system without a filter. A filter is required to protect the coil, blower, and internal parts from excessive dirt and dust. The filter is placed in the return duct by the installer.

- Inspect air filters at least once a month and replace or clean as required. Dirty filters are the most common cause of inadequate heating or cooling performance.
- Replace disposable filters. Cleanable filters can be cleaned by soaking in mild detergent and rinsing with cold water.
- Install new/clean filters with the arrows on the side pointing in the direction of air flow. Do not replace a cleanable (high velocity) filter with a disposable (low velocity) filter unless return air system is properly sized for it.

- If water should start coming from the secondary drain line, a problem exists which should be investigated and corrected. Contact a qualified service technician.

Repairing or Replacing Cabinet Insulation

⚠ IMPORTANT

DAMAGED INSULATION MUST BE REPAIRED OR REPLACED before the unit is put back into operation. Insulation loses its insulating value when wet, damaged, separated or torn.

Matte- or foil-faced insulation is installed in indoor equipment to provide a barrier between outside air conditions (surrounding ambient temperature and humidity) and the varying conditions inside the unit. If the insulation barrier is damaged (wet, ripped, torn or separated from the cabinet walls), the surrounding ambient air will affect the inside surface temperature of the cabinet.

The temperature/humidity difference between the inside and outside of the cabinet can cause condensation on the inside or outside of the cabinet which leads to sheet metal corrosion and, subsequently, component failure.

REPAIRING DAMAGED INSULATION

Areas of condensation on the cabinet surface are an indication that the insulation is in need of repair.

If the insulation in need of repair is otherwise in good condition, the insulation should be cut in an X pattern, peeled open, glued with an appropriate all-purpose glue and placed back against the cabinet surface, being careful to not overly compress the insulation so the insulation can retain its original thickness. If such repair is not possible, replace the insulation. If using foil-faced insulation, any cut, tear, or separations in the insulation surface must be taped with a similar foil-faced tape.

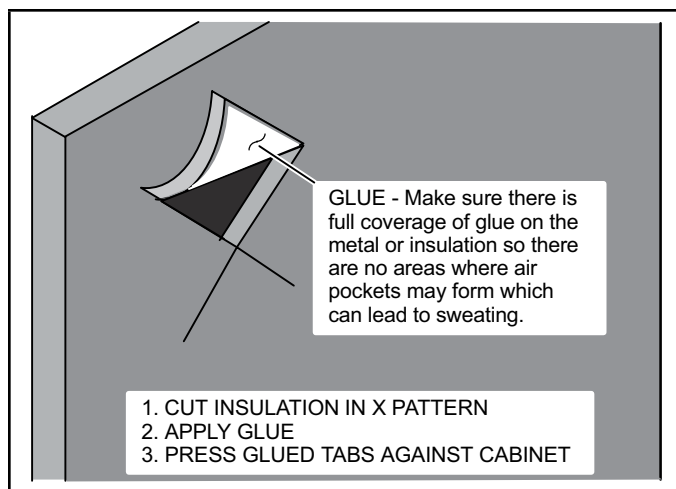

FIGURE 21. Repairing Insulation

Professional Maintenance

NOTICE !

Failure to follow instructions will cause damage to the unit.

This unit is equipped with an aluminum coil. Aluminum coils may be damaged by exposure to solutions with a pH below 5 or above 9. The aluminum coil should be cleaned using potable water at a moderate pressure (less than 50psi). If the coil cannot be cleaned using water alone, Allied recommends use of a coil cleaner with a pH in the range of 5 to 9. The coil must be rinsed thoroughly after cleaning.

In coastal areas, the coil should be cleaned with potable water several times per year to avoid corrosive buildup (salt).

Use of Air Handler During Construction

Allied does not recommend the use of its air handler unit during any phase of construction. Very low return air temperatures, harmful vapors and operation of the unit with clogged or misplaced filters will damage the unit.

Air handler units may be used for heating (heat pumps) or cooling of buildings under construction, if the following conditions are met:

- A room thermostat must control the air handler. The use of fixed jumpers is not allowed.
- Air filter must be installed in the system and must be maintained during construction.
- Air filter must be replaced upon construction completion.
- The air handler evaporator coil, supply fan assembly and duct system must be thoroughly cleaned following final construction clean-up.
- All air handler operating conditions must be verified according to these installation instructions.
- Ensure that sensor opening is clear and free of debris. Follow sensor maintenance recommendations as outlined in sensor kit instruction.
- Ensure that sensor opening is clear and free of debris.



FIGURE 22. Example of Clear, Unobstructed Sensor Inlet

Sensor Maintenance

It is recommended to check the state of the sensor every 6 months, at the beginning of each cooling and heating season.

- Ensure that the sensor opening is clear and free of debris.
- Check that the sensor cable is in good condition.
- DO NOT use abrasive cleaning solutions or detergents to clean sensor opening.
- DO NOT use flammable compressed air solutions to clean the sensor opening.
- DO NOT vacuum sensor inlet opening, as this could cause damage to the sensor internal components.
- Replace sensor if the opening is not clean or free of debris
- When cleaning the evaporator coil, remove sensor from the coil. Follow recommended coil cleaning guidelines as described in installation instructions.

Modes of Operation

The modes of operation for the RDS Non-Communicating Blower Control Board are Initializing, Normal, Leak Detected, and Fault.

Initializing

The RDS Non-Communicating Blower Control Board is establishing connection with the refrigerant detection sensor and is completing an initial five (5) minute purge sequence.

Normal

The HVAC system is functioning normally. The RDS Non-Communicating Blower Control Board has not detected a refrigerant leak.

Leak Detected

When the RDS Non-Communicating Blower Control Board detects a refrigerant leak:

- 1 - The RDS Non-Communicating Blower Control Board shuts off the (R) input (24VAC power) to the thermostat, which de-energizes the outdoor unit compressor and heat sources, such as gas and/or electric strip heat. No heating or cooling demands will be met.
- 2 - The RDS Non-Communicating Blower Control Board activates the blower (high speed). The blower purges refrigerant from the cabinet, plenum, and ductwork.
- 3 - After the RDS Non-Communicating Blower Control Board determines the refrigerant levels are below the safety threshold, the blower will continue to function for an additional seven (7) minutes.
- 4 - After the blower sequence is complete, the HVAC system resumes normal operation.

NOTE – The HVAC system may not maintain a cooling or heating setpoint if a significant leak exists. Any refrigerant leaks that remain unaddressed for an extended time may cause the HVAC system to shut down on a low refrigerant pressure limit condition.

Fault

When a fault is detected within the RDS Non-Communicating Blower Control Board, the indoor unit blower engages and remains engaged at a constant output until the fault is cleared.

Diagnostic Codes

The RDS Non-Communicating Blower Control Board is equipped with a multicolor LED within its enclosure. The LED signals the state of the RDS Non-Communicating Blower Control Board.

See Table 12 to review the diagnostic codes.

TABLE 12. LED Diagnostic Codes

State	LED Diagnostic Code	Action
Initializing	Flashing green ¹	Not Applicable
Monitoring	Solid green with blue flash ²	Not Applicable
Mitigating (Leak Detected)	Flashing blue	Check coil tubes for leak. Repair the issue and restart the equipment.
Fault/Service	Solid blue, interrupted by issue flash code	Refer to Table 17 for troubleshooting steps.

1. A rapid flash indicates the RDSC is in the process of sensor enumeration

2. A blue flash indicates the mitigation process has previously occurred.

Red LED Diagnostic Codes

Red diagnostic codes indicate a specific RDS Non-Communicating Blower Control Board issue. Yellow diagnostic codes indicate the sensor's position (if applicable).

TABLE 13. Red LED Diagnostic Codes

Red Flash	Applies to Individual Sensor(s)	Issue	Action
1	Yes	Sensor indicates fault	Replace the sensor (Cat. # 27J27)
2	No	Float Switch Active	Check if drain line float switch is installed. If no float switch is installed check jumper on control board.
3	Yes	Incompatible sensor type	Replace with a compatible sensor (Cat. # 27J27)
4	Yes	Sensor communications issue	Check sensor connection. Ensure connection is clean and tight.
5	No	R-input not available	Check for 24VAC power connection to the R terminal inputs on the RDSC. R-inputs must be energized for the RDSC to function.

Test Button Functionality

The RDS Non-Communicating Blower Control Board is equipped with a Test/Reset button. The Test button can be used to complete several functions, depending on the mode of operation of the RDS Non-Communicating Blower Control Board.

Table 14 lists the functions of the Test button during each mode of operation.

TABLE 14. Test Button Function

Mode of Operation	Press the Test Button to...
Normal	Trigger a leak detection response. Verify all equipment is wired correctly into the RDSC (after installation).
Leak Detected	Reset the RDSC to a normal mode of operation after a previous leak has been detected and purged from the HVAC system.
Fault	Reset the RDSC after troubleshooting and resolving a fault condition. If the fault is not resolved, the RDSC will enter the Fault mode again.

Test Button - Additional Functions

Table 15 lists the additional functions of the Test Button while the RDS Non-Communicating Blower Control Board is functioning within the states of Initializing, Monitoring, Leak Detection, Servicing and Fault. Refer to "Table 12. LED Diagnostic Codes".

TABLE 15. Additional Button Functions

State	Press	Action
Initializing	Short	Skips remaining pre-purge after sensors are recognized by the RDSC
Initializing	Long	Reset control
Monitoring	Short	Clear purge-counter if prior mitigation has occurred; Test mitigation
Monitoring	Long	Reset control
Mitigating	Short	If testing mitigation, end test
Servicing	Short	Reevaluate fault condition - if cleared return to monitoring, otherwise update indicator
Servicing	Long	Reset control
Fault	Short	Reevaluate fault condition - if cleared return to monitoring, otherwise update indicator
Fault	Long	Reset control

Thermostat Compatibility

Thermostats that preserve memory settings are compatible with the RDS Non-Communicating Blower Control Board. Examples include:

- Battery-powered thermostats
- Analog thermostats
- Smart thermostats
- Late-model programmable thermostats
- *Early-generation digital and programmable thermostats may not retain the operation mode and temperature setpoints after a power outage.*

The following scenarios are likely to occur when home occupants are not available to adjust the thermostat setpoints as the system is recovering from leak detection and resuming normal operation:

- Heating could be lost during a cold night
- Cooling could be lost during a hot day
- The thermostat could reset to an incorrect temperature setpoint

Compatibility Verification

Complete the following process to determine whether the thermostat is compatible with the RDS Non-Communicating Blower Control Board.

- 1 - Change the thermostat's current setpoint and operating mode.
- 2 - Power cycle the breaker to the furnace.

NOTE – Wait five (5) minutes before supplying power to the furnace breaker.

- 3 - Note whether the thermostat maintained its setpoints and operating mode.
 - a. If the thermostat maintained the settings, the thermostat is compatible with the RDS Non-Communicating Blower Control Board.
 - b. If the thermostat did not maintain its setpoint and/or operating mode, the thermostat is not compatible with the RDS Non-Communicating Blower Control Board. Recommend replacing with a compatible thermostat.

Additional Applications

In zoned applications, all dampers will remain open when the RDS Non-Communicating Blower Control Board is in Fault or Leak Detected mode. Normal heating and cooling demands are permissible, but the blower will remain engaged until the fault condition is addressed.

Zone HVAC System

If the RDS Non-Communicating Blower Control Board is installed in a zone HVAC system, the RDS Non-Communicating Blower Control Board will open all zone dampers if a leak is detected.

NOTE – Proper wiring of the zone panel to the RDS Non-Communicating Blower Control Board is required for all zone dampers to open.

After the purge sequence is complete, the zone system will resume normal operation.

External Alarm

(For applications with external alarms wired directly to the RDS Non-Communicating Blower Control Board.)

The RDS Non-Communicating Blower Control Board triggers the external alarm system when it enters Leak Detected mode. For alarm notifications, the RDS Non-Communicating Blower Control Board provides a dry relay contact that is rated 3A at 30 VAC/DC.

Start Up Test Procedure

The RDS Non-Communicating Blower Control Board is equipped with a Test/Reset button, see “Test Button Functionality” on page 29. After the RDS Non-Communicating Blower Control Board has been mounted and wired, restore power to the HVAC system. The system will then run through a purge sequence for five (5) minutes. After the purge sequence is complete, proceed to testing cooling demand and heating demand.

Cooling Demand

- 1 - Prompt a cooling demand at the thermostat.
- 2 - Press the Test button on the RDS Non-Communicating Blower Control Board.

The system then executes a leak detection response.
- 3 - Observe the following sequence:
 - a. The LED indicator flashes the sequence for leak detection (flashing blue).
 - b. The blower powers up.
 - c. The outdoor compressor powers down.
- 4 - Press the Test button to terminate the simulated Leak Detected mode upon test completion.

Heating Demand

- 1 - Prompt a heating demand at the thermostat.
- 2 - Press the Test button on the RDS Non-Communicating Blower Control Board.

The system then executes a leak detection response.
- 3 - Observe the following sequence:
 - a. The LED indicator flashes the sequence for leak detection (flashing blue).
 - b. The blower powers up.
 - c. The gas burners power down.
 - d. The outdoor compressor powers down.
- 4 - Press the Test button to terminate the simulated Leak Detected mode upon test completion.

The installation of the RDS Non-Communicating Blower Control Board is complete after both sequences are successfully completed.

Diagnostic Codes and Troubleshooting

TABLE 16. LED Diagnostic Codes

State	LED Diagnostic Code	Action Required
Initializing	Flashing green	None
Monitoring	Solid green. If a prior mitigation occurred, a blue flash interrupts the solid green LED.	None
Mitigating (Leak Detected)	Flashing blue	Check coil tubes for leak. Repair the issue and restart the equipment.
Fault/Service	Solid blue, interrupted by issue diagnostic code	Refer to Table 17 for troubleshooting steps.

TABLE 17. Red LED Diagnostic Codes / Troubleshooting

Red Flash	Applies to Individual Sensor(s)	Issue	Action Required
1	Yes	Sensor indicates fault	Replace the sensor
2	No	Float Switch Active	Check if drain line float switch is installed. If no float switch is installed check jumper on control board.
3	Yes	Incompatible sensor type	Replace the sensor
4	Yes	Sensor communications issue	Check sensor connection. Ensure connection is clean and tight.
5	No	R-input not available	Check sensor connections. Ensure connection is clean and tight.

Decommissioning

Before carrying out this procedure, it is essential that the technician is completely familiar with the equipment and all its detail. It is recommended good practice that all refrigerants are recovered safely.

Prior to the task being carried out, an oil and refrigerant sample shall be taken in case analysis is required prior to re-use of recovered refrigerant. It is essential that electrical power is available before starting decommissioning.

- a) Become familiar with the equipment and its operation.
- b) Isolate system electrically.
- c) Before attempting the procedure, ensure that:
 - mechanical handling equipment is available, if required, for handling refrigerant cylinders;
 - all personal protective equipment is available and being used correctly;
 - the recovery process is supervised at all times by a competent person;
 - recovery equipment and cylinders conform to the appropriate standards.
- d) Pump down refrigerant system, if possible.
- e) If a vacuum is not possible, make a manifold so that refrigerant can be removed from various parts of the system.
- f) Make sure that cylinder is situated on the scales before recovery takes place.

- g) Start the recovery machine and operate in accordance with instructions.
- h) Do not overfill cylinders (no more than 80% volume liquid charge).
- i) Do not exceed the maximum working pressure of the cylinder, even temporarily.
- j) When the cylinders have been filled correctly and the process completed, make sure that the cylinders and the equipment are removed from site promptly and all isolation valves on the equipment are closed off.
- k) Recovered refrigerant shall not be charged into another REFRIGERATING SYSTEM unless it has been cleaned and checked.

IMPORTANT

Equipment shall be labelled stating that it has been decommissioned and emptied of refrigerant. The label shall be signed and dated. Ensure that there are labels on the equipment that state the flammability of the refrigerant used.

Installing Contractor's Name _____
 Installing Contractor's Phone _____
 Job Address _____

Installing Date _____
 Air Handler Model # _____

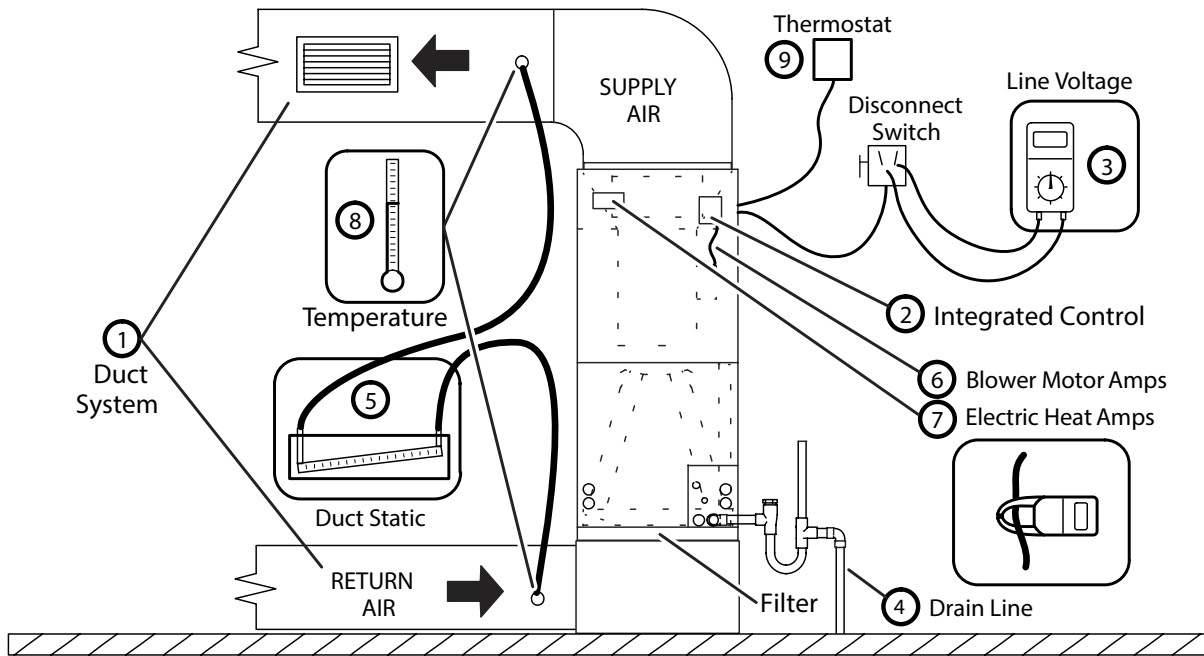

- | | |
|---|---|
| <p>① DUCT SYSTEM</p> <p>SUPPLY AIR DUCT</p> <p><input type="checkbox"/> Sealed</p> <p><input type="checkbox"/> Insulated (if necessary)</p> <p><input type="checkbox"/> Registers Open and Unobstructed</p> <p>RETURN AIR DUCT</p> <p><input type="checkbox"/> Sealed</p> <p><input type="checkbox"/> Filter Installed and Clean</p> <p><input type="checkbox"/> Registers Open and Unobstructed</p> <p>② INTEGRATED CONTROL</p> <p><input type="checkbox"/> Jumpers Configured Correctly (if applicable)</p> <p><input type="checkbox"/> Appropriate Links in Place (if applicable)</p> <p>③ VOLTAGE CHECK</p> <p><input type="checkbox"/> Supply Voltage _____</p> <p><input type="checkbox"/> Low Voltage _____</p> <p><input type="checkbox"/> Electrical Connections Tight</p> <p>④ DRAIN LINE</p> <p><input type="checkbox"/> Leak Free</p>
<p><input type="checkbox"/> Explained Operation of System to Homeowner</p> | <p>⑤ TOTAL EXTERNAL STATIC (dry coil)</p> <p style="text-align: right;">dry coil wet coil</p> <p>Supply External Static _____</p> <p>Return External Static _____</p> <p>Total External Static = _____</p> <p>⑥ ELECTRIC HEAT AMPS _____</p> <p>⑦ INDOOR BLOWER AMPS _____</p> <p>INDOOR BLOWER CFM _____</p> <p>⑧ TEMPERATURE DROP (Cooling Mode)</p> <p>Return Duct Temperature _____</p> <p>Supply Duct Temperature - _____</p> <p>Temperature Drop = _____</p> <p>⑧ TEMPERATURE RISE (Heating Mode)</p> <p>Return Duct Temperature _____</p> <p>Supply Duct Temperature - _____</p> <p>Temperature Rise = _____</p> <p>⑨ THERMOSTAT</p> <p><input type="checkbox"/> Adjusted and Programmed</p> <p><input type="checkbox"/> Operation Explained to Owner</p> |
|---|---|

Technician's Name: _____ Date Start _____ –Up & Performance Check Completed _____

FIGURE 23. Start-up and Performance Checklist (Upflow Configuration)

Installing Contractor's Name _____
 Installing Contractor's Phone _____
 Job Address _____

Installing Date _____
 Air Handler Model # _____

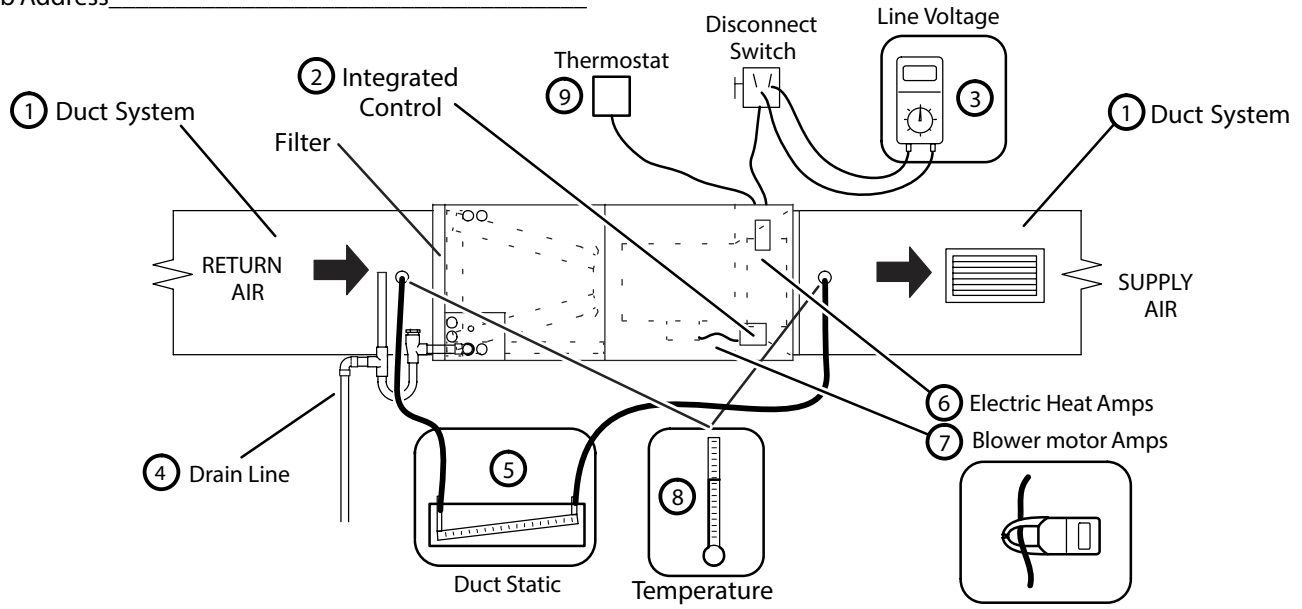

- | | |
|---|---|
| <p>1 DUCT SYSTEM</p> <p>SUPPLY AIR DUCT</p> <p><input type="checkbox"/> Sealed</p> <p><input type="checkbox"/> Insulated (if necessary)</p> <p><input type="checkbox"/> Registers Open and Unobstructed</p> <p>RETURN AIR DUCT</p> <p><input type="checkbox"/> Sealed</p> <p><input type="checkbox"/> Filter Installed and Clean</p> <p><input type="checkbox"/> Registers Open and Unobstructed</p> <p>2 INTEGRATED CONTROL</p> <p><input type="checkbox"/> Jumpers Configured Correctly (if applicable)</p> <p><input type="checkbox"/> Appropriate Links in Place (if applicable)</p> <p>3 VOLTAGE CHECK</p> <p><input type="checkbox"/> Supply Voltage _____</p> <p><input type="checkbox"/> Low Voltage _____</p> <p><input type="checkbox"/> Electrical Connections Tight</p> <p>4 DRAIN LINE</p> <p><input type="checkbox"/> Leak Free</p> | <p>5 TOTAL EXTERNAL STATIC (dry coil)</p> <p style="text-align: right;">dry coil wet coil</p> <p>Supply External Static _____</p> <p>Return External Static _____</p> <p>Total External Static = _____</p> <p>6 ELECTRIC HEAT AMPS _____</p> <p>7 INDOOR BLOWER AMPS _____</p> <p>INDOOR BLOWER CFM _____</p> <p>8 TEMPERATURE DROP (Cooling Mode)</p> <p>Return Duct Temperature _____</p> <p>Supply Duct Temperature - _____</p> <p>Temperature Drop = _____</p> <p>8 TEMPERATURE RISE (Heating Mode)</p> <p>Return Duct Temperature _____</p> <p>Supply Duct Temperature - _____</p> <p>Temperature Rise = _____</p> <p>9 THERMOSTAT</p> <p><input type="checkbox"/> Adjusted and Programmed</p> <p><input type="checkbox"/> Operation Explained to Owner</p> |
|---|---|

Explained Operation of System to Homeowner

Technician's Name: _____ Date Start _____ –Up & Performance Check Completed _____

FIGURE 24. Start-Up and Performance Checklist (Horizontal Configuration)