

# INSTALLATION INSTRUCTIONS

## 7EHX

## R410A Horizontal Indoor Coils

This manual must be left with the homeowner for future reference.

### WARNING

Improper installation, adjustment, alteration, service or maintenance can cause property damage, personal injury or loss of life. Installation and service must be performed by a licensed professional installer (or equivalent), service agency or the gas supplier.

### WARNING

Risk of explosion or fire.  
Can cause injury or death.  
Recover all refrigerant to relieve pressure before opening the system.

### CAUTION

As with any mechanical equipment, contact with sharp sheet metal edges can result in personal injury. Take care while handling this equipment and wear gloves and protective clothing.

### WARNING

Maximum altitude of application is 3200m above sea level.

Allied Air Enterprises, LLC  
215 Metropolitan Drive  
West Columbia, SC 29170

### IMPORTANT

If installing in an R454B application, R454B coil sensor kit (26Z69), Refrigerant Detection System Control (27A05 or 27A06)\* and R454B TXV (26Z70, 26Z71, or 26Z72) must be ordered.

If installing in an R454B application, use installation instructions provided in R454B coil conversion kit (26Z69).

For sensor maintenance recommendations refer to the instructions in kit 26Z69.

\*For non-communicating furnaces, order kit 27A05. For communicating furnaces, order kit 27A06.

### WARNING

Every working procedure that affects safety means shall only be carried out by competent persons. This appliance is not to be used by persons (including children) with reduced physical, sensory or mental capabilities, or lack of experience and knowledge, unless they have been given supervision or instruction concerning use of the appliance by a person responsible for their safety. Children should be supervised to ensure they do not play with the appliance.

### IMPORTANT

The Clean Air Act of 1990 bans the intentional venting of refrigerant (CFCs, HCFCs and HFCs) as of July 1, 1992. Approved methods of recovery, recycling or reclaiming must be followed. Fines and/or incarceration may be levied for noncompliance.



(P) 508453-01

## Model Number Identification

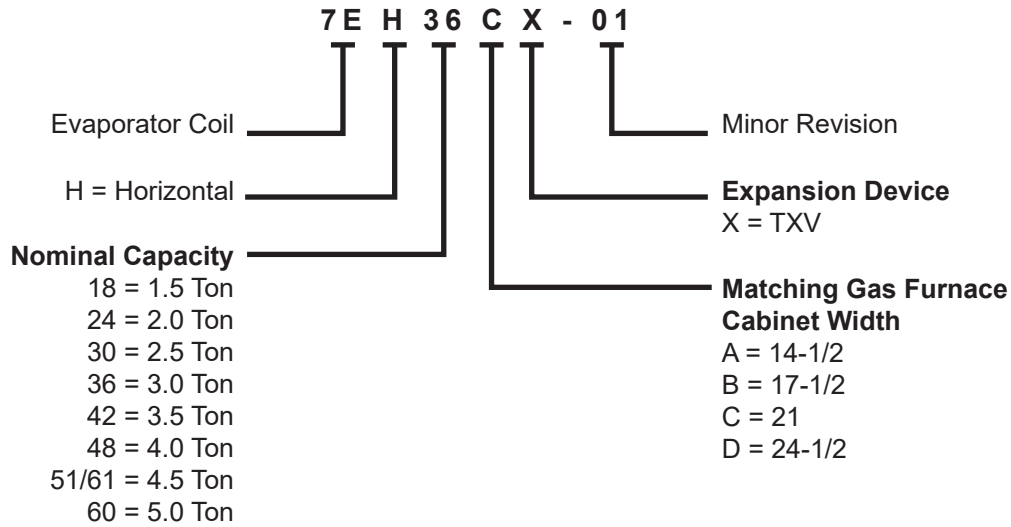

**NOTE:** This unit is a *PARTIAL UNIT AIR CONDITIONER*, complying with *PARTIAL UNIT* requirements of this Standard, and must only be connected to other units that have been confirmed as complying to corresponding *PARTIAL UNIT* requirements of this Standard, UL 60335-2-40/CSA C22.2 No. 60335-2-40, or UL 1995/CSA C22.2 No 236.

**NOTE:** *PARTIAL UNITS* shall only be connected to an appliance suitable for the same refrigerant.

**NOTE:** Special procedures are required for cleaning the aluminum coil in this unit. See Page 7 in this instruction for information.

### General

7EHX all-aluminum coil horizontal evaporator coils are designed for use with air conditioners and heat pumps and are supplied with a factory-installed HFC-410A check/expansion valve.

The coil drain pan is high quality engineering polymer with a maximum service temperature of 500°F. However, adequate space must be provided between the drain pan and furnace heat exchanger. At least 2" space is required for heat exchanger and 4" for drum-type or oil-fired furnace heat exchanger. Closer spacing may damage the drain pan and cause leaking.

Refer to the 7EHX Technical Specification for proper use of these coils with specific furnaces, air conditioners, heat pumps and line sets.

These instructions are intended as a general guide and do not supersede local or national codes in any way. Consult authorities who have jurisdiction before installation.

### Shipping and Packing List

Package 1 of 1 contains the following:

1 - 7EHX evaporator coil

Check the components for shipping damage. If you find any damage, immediately contact the last carrier.

### Releasing Air Charge

#### **CAUTION**

The coil is shipped from the factory pressurized with dry air. Pierce a hole in the rubber plug that seals the vapor line to relieve the pressure before removing the plugs.

**NOTE:** If there is no pressure released when the vapor line rubber plug is pierced, check the coil for leaks before continuing with the installation.

The coil is shipped with a 10 + 3 psig dry air holding charge. Puncture the suction line rubber plug to release the charge. Remove the rubber plug. Ensure that the coil is void of pressure.

## Installation

### WARNING

Risk of explosion or fire.

Can cause injury or death.

Recover all refrigerant to relieve pressure before opening the system.

Install the furnace or air handler according to the installation instructions provided with the unit.

**NOTE:** In areas of high humidity, use foam tape to insulate the suction line section in the cabinet as shown in Figure 1.

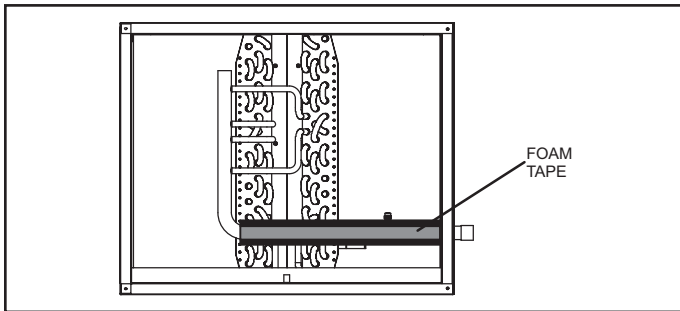

**Figure 1. Insulate Suction Line Inside Cabinet**

- 1. Left-Hand and Right-Hand Discharge** — The coil must have a 1/2" slope from the rear of the cabinet to the drain. Position the coil adjacent to the furnace cabinet and align the six screw clearance holes in the coil casing with the furnace engagement holes. Use six field-provided #8 X 1" screws to secure the coil casing to the furnace (see Figure 3 and Figure 4).
- 2. Right-Hand Air Discharge with Field-Provided Spacer** — The coil must have a 1/2" slope from the rear of the cabinet to the drain. Position the coil in the

left-to-right configuration on the service access side of the furnace. Insert a field-provided spacer between the furnace and the coil. Use field-provided screws to secure the coil casing, spacer and the furnace together. The spacer should be long enough to allow room for proper installation (approximately 6 inches minimum). See Figure 5.

**NOTE:** When the coil is connected directly with a condensing furnace, the coil must be level from return end to supply end. The front (access side) of the furnace may be pitched downward up to 1 inch to accommodate a 1/2-inch pitched coil.

3. Secure the supply duct to the coil cabinet.
4. Refer to the instructions provided with the condensing unit for leak testing, evacuating and charging procedures. Always check the entire system for leaks before charging.
5. **Applications using 7EHX-60 D-width unit with C-width furnace** — Figure 2 shows an application that includes a D-width coil and a C-width furnace. This application requires construction of an insulated, field-supplied block-off plate to cover the open space on the coil housing.

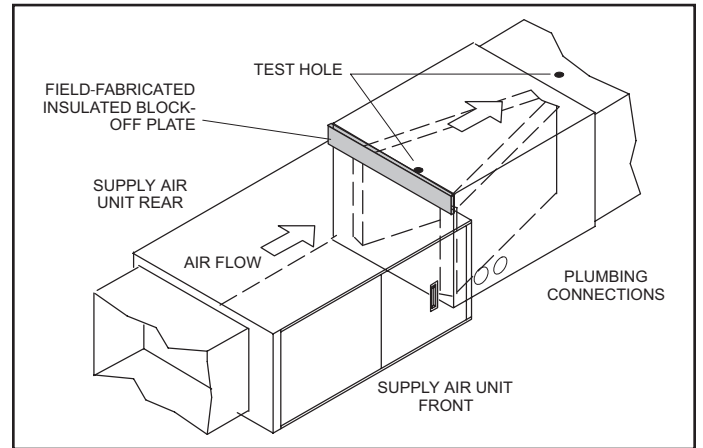

**Figure 2. D-Width Coil with C-Width Furnace**

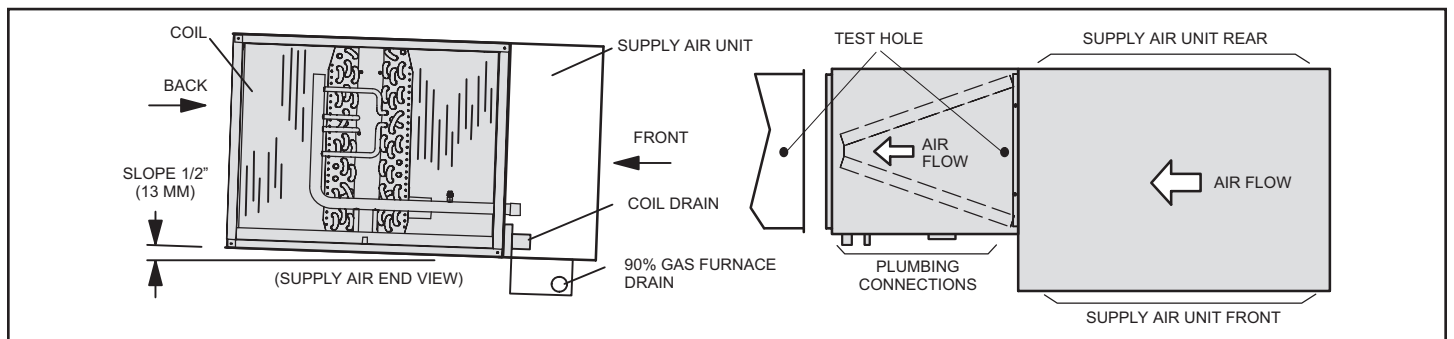

**Figure 3. Left-Hand Air Discharge**

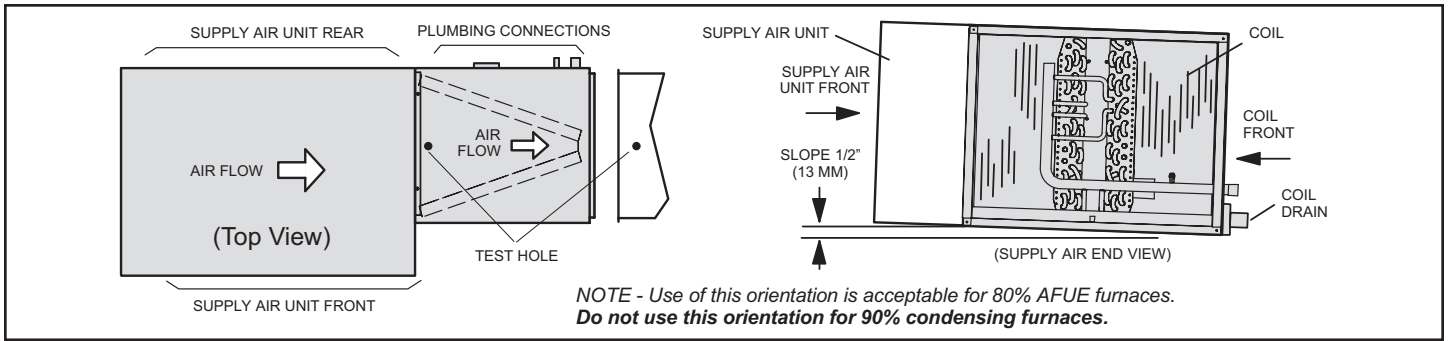

**Figure 4. Right-Hand Air Discharge**

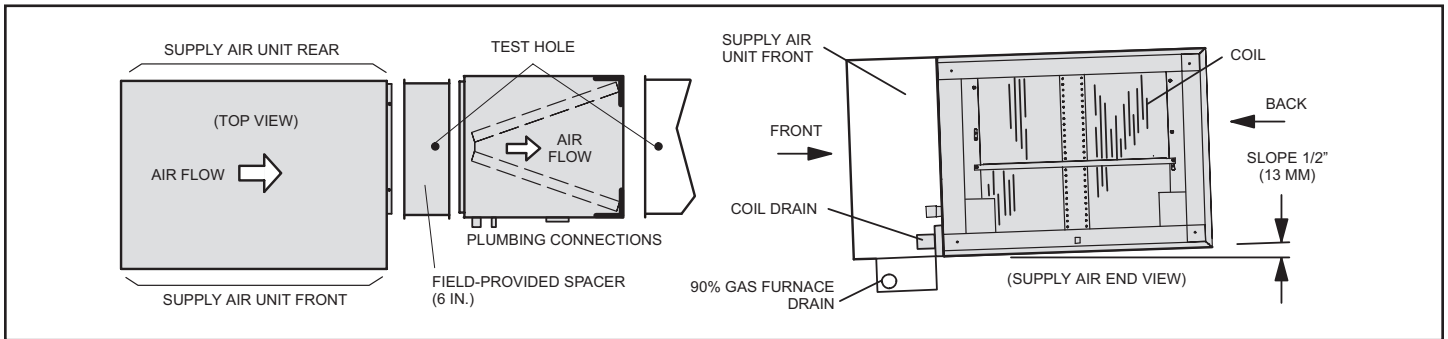

**Figure 5. Right-Hand Air Discharge with Spacer**

## Refrigerant Line Connections

### Line Sizes

The refrigerant line sets should be sized according to the recommendations given in the outdoor unit installation instructions. See Table 1 for sweat connection sizes. A field-provided adapter may be required to match line set connections.

Model	Suction Line Connection	Liquid Line Connection
All	7/8 inch	3/8 inch

**Table 1. Refrigerant Line Connections**

### Replacement Parts

If replacement parts are needed for the liquid line orifice housing or assembly, order kit 69J46. The kit includes:

- 10 - Brass nuts for liquid line assemblies
- 20 - Teflon rings
- 10 - Liquid line orifice housings
- 10 - Liquid line assemblies

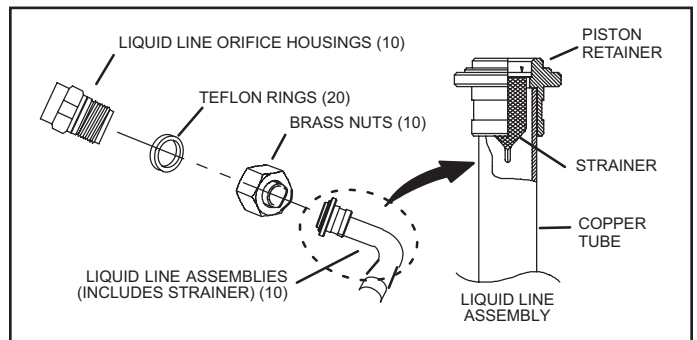

**Figure 6. Liquid Line Orifice Kit (69J46) Components**

### Brazing Guidelines

**NOTE: For R454B refrigerant installations, do not braze the line set to the evaporator coil until the outdoor unit is installed. Line set joint sleeves must be installed on the liquid and suction lines prior to line set brazing. Refer to R454B Coil Conversion Kit (26Z69) instructions for installation details.**

Use a silver alloy brazing rod (5 or 6 percent silver alloy for copper-to-copper connections or 45 percent silver alloy for copper-to-brass or copper-to-steel connections).

Use AL822 Flux Cord Solder Stickers (catalog number Y6331) for aluminum to aluminum joints.

Before making brazed connections, place a field-provided heat shield, such as a wet rag, against the unit cabinet and around the piping stubs, expansion valve, sensing bulb and line set joint sleeve, if present. The heat shield must be in place to prevent heat damage during brazing. See Figure 7.

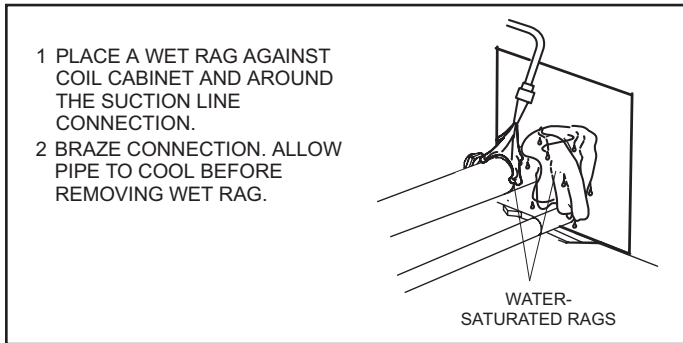

**Figure 7. Brazing Refrigerant Lines**

### Suction Line Connection

Use the following procedure to connect the suction line to the indoor coil:

1. Remove rubber plug from the stubbed connection.
2. Position the properly sized refrigerant piping and make the brazed connection following the brazing guidelines.
3. Do not remove the water-saturated rags from the cabinet and piping until the piping has cooled completely.

### Liquid Line Connection

**NOTE:** Before the liquid line connections can be made, the factory-provided refrigerant metering orifice must be removed and a properly sized expansion valve must be field-installed.

The system must include a properly matched expansion valve which must be field-provided and installed. The 7EHX is shipped with a factory-installed refrigerant metering orifice. The orifice must be removed BEFORE a properly sized expansion valve is installed.

### Leak Testing, Evacuating and Charging

**NOTE:** Refrigerant system installations shall be installed and tested per ASHRAE Standard 15.2, Section 10.0 (latest edition).

Refer to the outdoor unit instruction for leak testing, evacuating and charging procedures. Always leak check entire system before charging.

The following best practices are recommended to ensure better condensate removal:

- Main and overflow drain lines should NOT be smaller than both drain connections at drain pan.
- Overflow drain line should run to an area where homeowner will notice drainage.
- It is recommended that the overflow drain line be vented and a trap installed. Refer to local codes.

### Sealing Ducts

Ensure the duct is secured and all joints are properly sealed to the coil cabinet flanges.

### **WARNING**

There must be an airtight seal between the bottom of the furnace and the return air plenum. Use fiberglass sealing strips, caulking, or equivalent sealing method between the plenum and the air handler cabinet to ensure a tight seal. Return air must not be drawn from a room where this air handler or any gas-fueled appliance (i.e., water heater), or carbon monoxide-producing device (i.e., wood fireplace) is installed.

### **IMPORTANT**

**DUCT SYSTEM SIZING** - The duct system should be properly sized and installed according to the ASHRAE Standard Manual D. The supply and return air duct systems should be designed for the cfm and static requirements of the job. Consult the blower performance chart in the unit installation instructions to verify that the blower meets the application requirements.

### Condensate Drain Connections

### **IMPORTANT**

After removal of drain pan plug(s), check drain hole(s) to verify that drain opening is fully open and free of any debris. Also check to make sure that no debris has fallen into the drain pan during installation that may plug up the drain opening.

### Main Drain

Connect the main drain and route downward to drain line or sump. Do not connect drain to a closed waste system. See Figure 9 for typical drain trap configuration.

## Overflow Drain

It is recommended that the overflow drain is connected to an overflow drain line for all units. If overflow drain is not connected, it must be plugged with provided cap.

## Best Practices

The following practices are recommended to ensure better condensate removal:

- Main and overflow drain lines should NOT be smaller than drain connections at drain pan.
- Overflow drain line should run to an area where homeowner will notice drainage.
- It is recommended that the overflow drain line be vented and a trap installed. Refer to local codes.

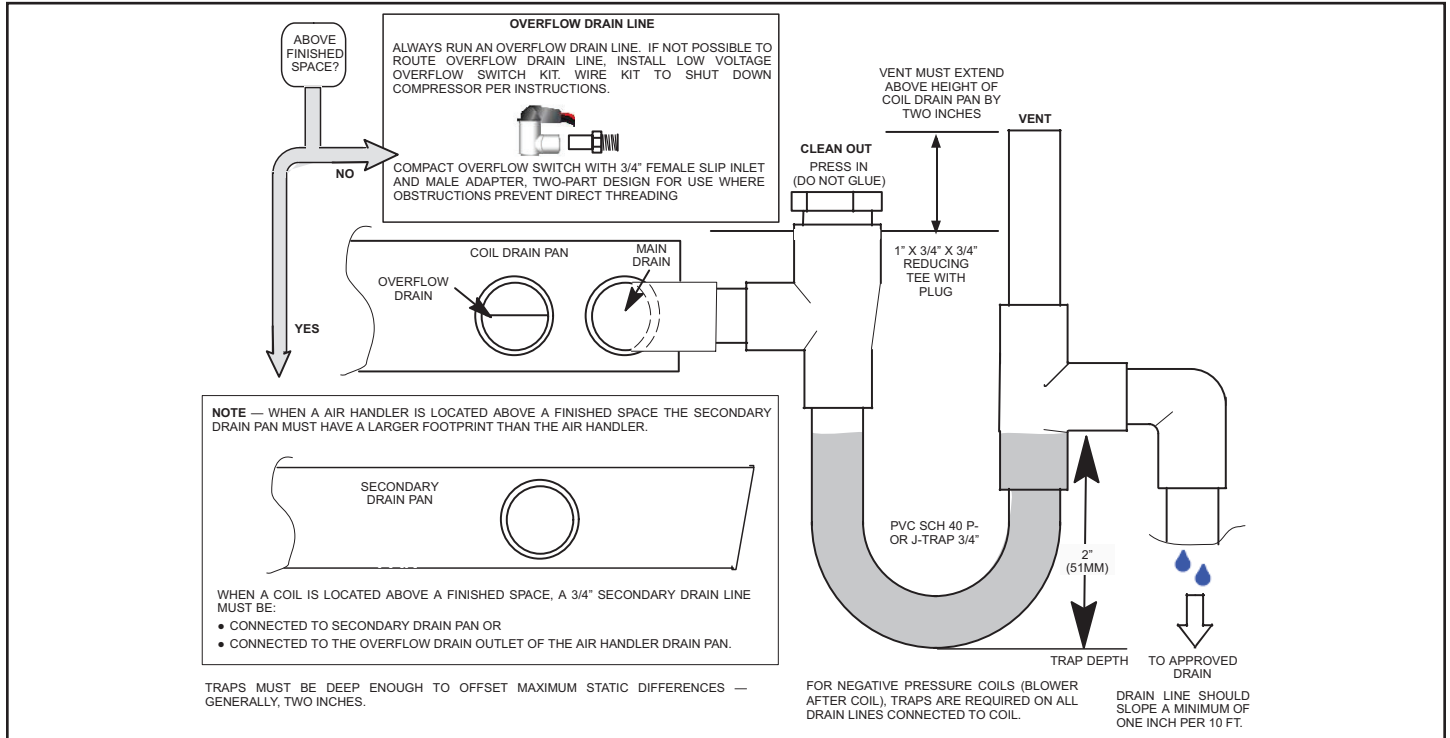

Figure 9. Typical Main and Overflow Drain Installations

## Blower Speed Connection

Proper air volume must be provided over the evaporator coil. Select a blower motor speed tap that will provide 400 ± 50 CFM per 12,000 Btuh of cooling capacity (wet coil).

A static pressure reading must be taken to see if the pressure drops are within the proper range. See Figure 10 as an example to obtain an accurate reading.

To ensure accuracy, test the air on both sides of the coil. Refer to Figure 10 for location of two test holes.

### CAUTION

Take care when drilling test holes into the furnace flange and the duct. Drill holes away from refrigerant piping. Test holes should be drilled where specified in order to avoid unit damage.

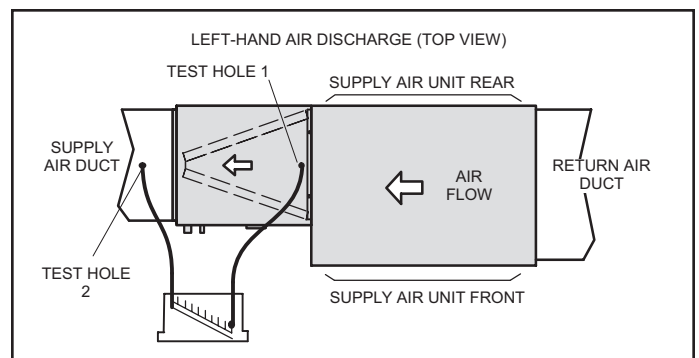

Figure 10. Static Pressure Test

1. Drill a 5/16" test hole in the coil case 1" from the furnace flange (test hole 1, Figure 10).
2. Drill a 5/16" test hole into the supply air duct (test hole 2, Figure 10).

3. Connect the zero end of the draft gauge scale to the furnace end of the coil. Insert the hoses so that 1/4" extends inside the duct or end seal. Seal around holes with Permagem.
4. Turn on the electrical power to the furnace and set the thermostat to initiate a cooling demand.
5. Table 2 lists the range of air volumes and equivalent draft gauge readings for this unit. Observe the draft gauge reading. If the reading is below the required air volume, increase the blower speed; if the reading is above the required air volume, decrease the blower speed. Refer to the furnace wiring diagram for blower speed settings.
6. When the required draft gauge readings are obtained, remove the draft gauge lines and insert snaphole plugs into the test holes.

Cabinet		Vol: CFM	Drop: in. w.g.	
Model	Width in.		Dry	Wet
-18A	14-1/2	600	.09	.11
-24A	14-1/2	800	.15	.19
-24B	17-1/2	800	.09	.11
-30A	14-1/2	1000	.24	.27
-30B	17-1/2	1000	.14	.16
-36A	14-1/2	1200	.30	.39
-36B	17-1/2	1200	.16	.21
-36C	21	1200	.15	.18
-42B	14-1/2	1400	.26	.31
-42C	17-1/2	1400	.18	.21
-48B	17-1/2	1400	.25	.29
-48C	21	1600	.27	.30
-51/61C	21	1600	.25	.29
-60D	24-1/2	2000	.24	.30

**Table 2. Air Volume/Static Pressure Drop Across Coil**

### Nameplate Marking

Prior to installing the front panel, mark the unit nameplate to permanently identify the refrigerant configuration. Nameplate example shown in Figure 11 below:

<b>FACTORY INSTALLED TXV SUITABLE FOR R-410A</b>	
<input checked="" type="checkbox"/> INSTALLED AS R-410A	<input type="checkbox"/> FIELD CONFIGURED TO R-22
<input type="checkbox"/> FIELD CONFIGURED TO R-454B	

Figure 11. Nameplate Marking

## Maintenance

### Cleaning The Coil

The coil should be inspected twice each year and cleaned at least once per year or more, if necessary. Indoor coil cleaning should be performed by a licensed professional service technician (or equivalent).

Do not use hydrofluoric acid, alkaline, or similar chemicals to clean coils. These chemicals are not necessary to dissolve salt, and may damage the fin coating. Acid washes are used to dissolve oils and greases, which generally are not present on residential applications.

Do not use alkaline washes. Alkaline washes are useful for dissolving oxides such as zinc oxide, aluminum oxide, and iron oxide (rust). However, these three oxides are more corrosion resistant than base metals, so dissolving or removing them will cause an increase in corrosion.

### CAUTION

A damaged coil fin can affect equipment operation and performance. Do not use flame, high-pressure water, steam, or volatile cleaners on fins or tubing surfaces. If cleaning requires the use of acidic or alkaline cleaners, follow the manufacturer's instructions. Thoroughly flush cleaner from all equipment components. (Be careful to prevent damage or corrosion of the components connected to the system or areas surrounding the equipment being cleaned.)

1. Before beginning this or any other maintenance, turn off all power to the indoor unit at the main unit disconnect switch. It is also recommended that you wear personal protective gear: safety glasses and/or a face shield, waterproof clothing and gloves.
2. Remove the coil from the indoor unit cabinet, and take the coil to a place that is appropriate for cleaning it.
3. Vacuum or brush the coil to remove matted and surface debris from the fins (dirt, hair, etc.). Use vacuum attachments and /or brushes that will not damage the coil fins.
4. Use only clean potable water to clean the coil. Clean the coil from top to bottom.

**NOTE:** For units in coastal regions, fresh water will dissolve away any salt deposits. (Wash coils with fresh water at least every six months.)

## NOTE

Failure to follow instructions will cause damage to the unit.

This unit is equipped with an aluminum coil. Aluminum coils may be damaged by exposure to solutions with a pH below 5 or above 9. The aluminum coil should be cleaned using potable water at a moderate pressure (less than 50psi). If the coil cannot be cleaned using water alone, it is recommended to use a coil cleaner with a pH in the range of 5 to 9. The coil must be rinsed thoroughly after cleaning.

In coastal areas, the coil should be cleaned with potable water several times per year to avoid corrosive buildup (salt).

5. Spray the coil at a vertical angle of 30 to 45 degrees with a constant stream of water at moderate pressure (less than 50 psig). A pressure washer with a fan nozzle will work best. Do not spray the coil from a horizontal direction. Direct the spray so that any debris is washed out of the coil and basepan. For most residential units, hot water is not necessary.

**NOTE:** *Attempting to back flush from the inside of the coil will require removing parts from the unit, and it may be very difficult to flush the whole coil surface. Attempting to blow water through a coil will slow the water stream and reduce the flushing action of the outer fin surface.*

6. Replace the coil into the cabinet or plenum. Ensure that you have followed the proper procedure for routing and securing the refrigerant tubing.

## IMPORTANT

Ensure that the distributor lines are not rubbing together or kinked. All tubes must have enough clearance from other metal parts. Use wire ties to secure tubes to prevent movement that could cause the refrigerant tubing to fail. Adjust the tubes as necessary.

### Use of Coil-Furnace System During Construction

Allied does not recommend the use of its coil-furnace system during any phase of construction. Very low return air temperatures, harmful vapors and operation of the unit with clogged or misplaced filters will damage the unit.

Coils may be used for heating (heat pumps) or cooling of buildings under construction, if the following conditions are met:

- A room thermostat must control the air handler. The use of fixed jumpers is not allowed.
- Air filter must be installed in the system and must be maintained during construction.
- Air filter must be replaced upon construction completion.

- The evaporator coil, furnace supply fan assembly and duct system must be thoroughly cleaned following final construction clean-up.
- All coil and furnace operating conditions must be verified according to these installation instructions.
- **R454B applications only:** If refrigerant leak detection sensor kit has been installed, ensure that sensor opening is clear and free of debris. Follow sensor maintenance recommendations as outlined in sensor kit instructions.

## Decommissioning

Before decommissioning, it is essential that the technician is completely familiar with the equipment and all its detail. It is recommended good practice that all refrigerants are recovered safely.

Before performing this task, an oil and refrigerant sample shall be taken in case analysis is required prior to re-use of recovered refrigerant. It is also essential that electrical power is available before starting decommissioning.

1. Become familiar with the equipment and its operation.
2. Isolate system electrically.
3. Before attempting the procedure, ensure that:
  - a. mechanical handling equipment is available, if required, for handling refrigerant cylinders;
  - b. all personal protective equipment is available and being used correctly;
  - c. the recovery process is supervised at all times by a competent person;
  - d. recovery equipment and cylinders conform to the appropriate standards.
4. Pump down refrigerant system, if possible.
5. If a vacuum is not possible, make a manifold so that refrigerant can be removed from various parts of the system.
6. Make sure that cylinder is situated on the scales before recovery takes place.
7. Start the recovery machine and operate in accordance with instructions.
8. Do not overfill cylinders (no more than 80% volume liquid charge).
9. Do not exceed the maximum working pressure of the cylinder, even temporarily.
10. When the cylinders have been filled correctly and the process completed, make sure that the cylinders and the equipment are removed from site promptly and all isolation valves on the equipment are closed off.
11. Recovered refrigerant shall not be charged into another REFRIGERATING SYSTEM unless it has been cleaned and checked.