

PRODUCT SPECIFICATIONS

Bulletin No. ZHA-036-060-50HZ (04/2019)

Z-SERIES™

DESIGNED TO FIT. FAST.

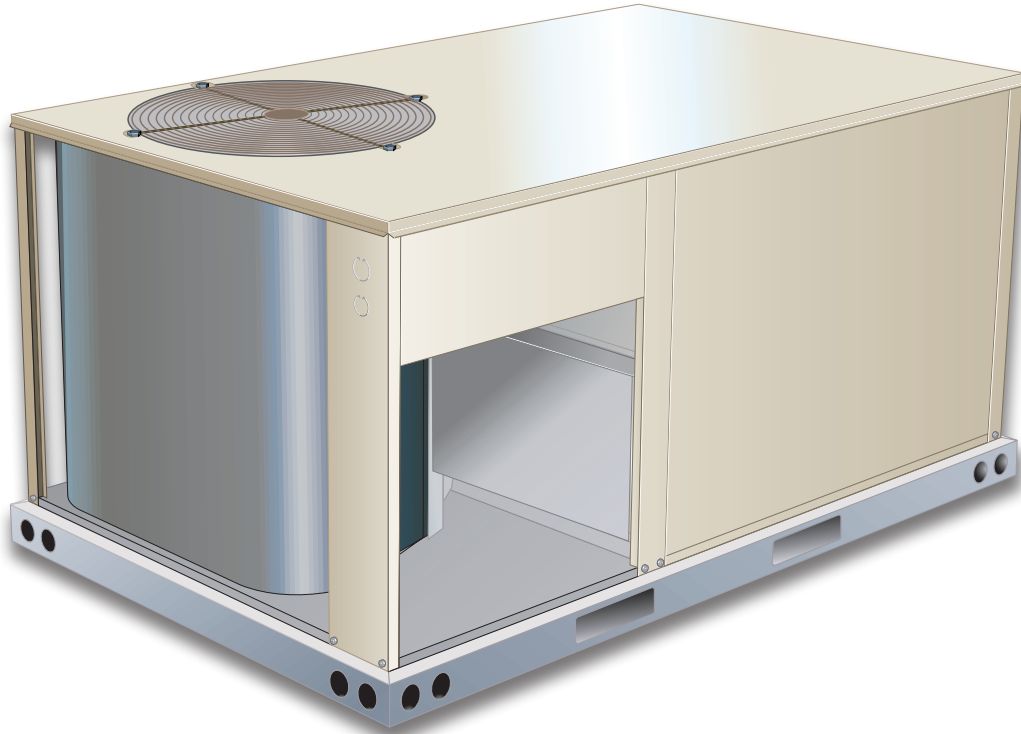

10.5 to 21.0 kW (3 to 6 Tons)

Net Cooling Capacity - 9.1 to 17.3 kW (31 200 to 59 000 Btuh)

Net Heating Capacity - 8.5 to 17.3 kW (29 000 to 59 000 Btuh)

Optional Electric Heat - 3.8 to 23.0 kW

MODEL NUMBER IDENTIFICATION

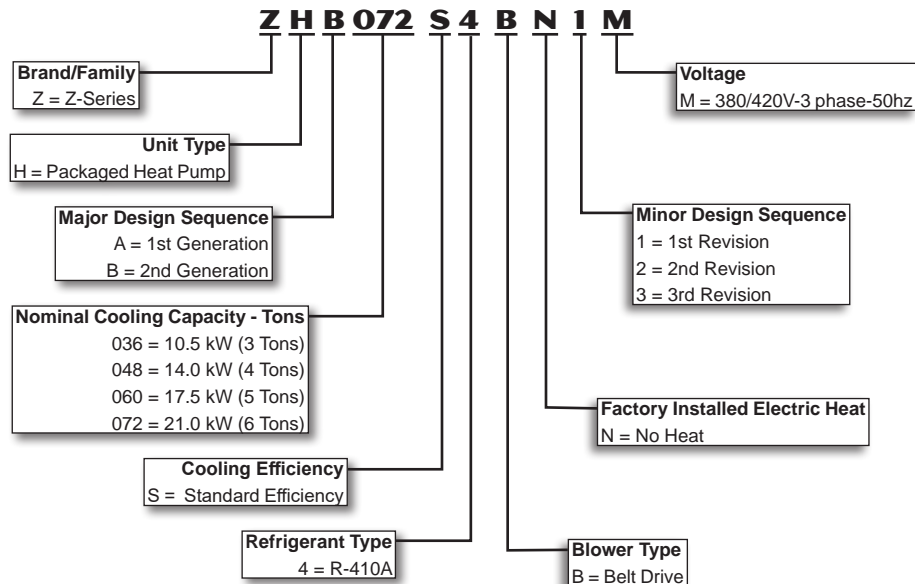

FEATURES AND BENEFITS

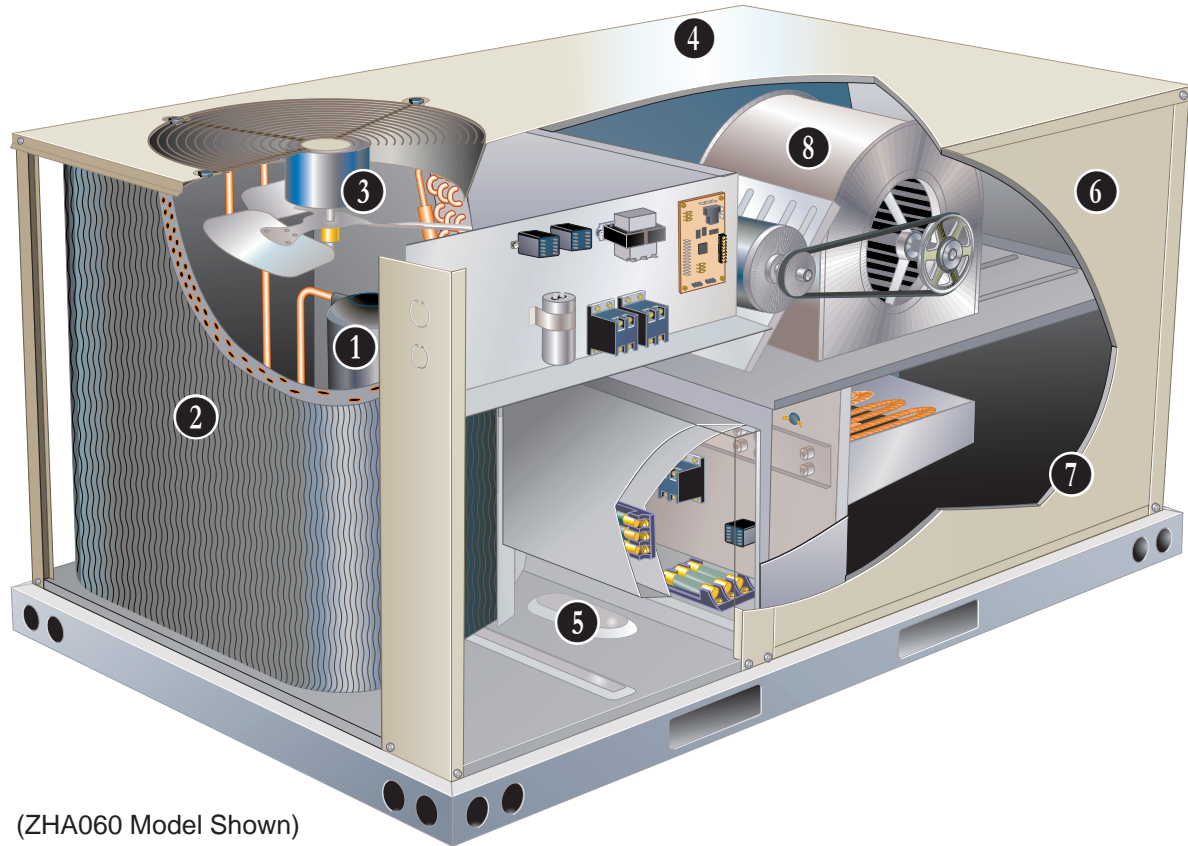

(ZHA060 Model Shown)

Z-Series™ rooftop units from Allied are the new standard for cost efficient, reliable rooftop units built for long-lasting performance that can significantly improve indoor environments. Z-Series™ rooftop units feature:

- **Quick and Easy Retrofit** - Fast installation for replacement of many existing rooftop units - fits high volume competitor's roof curbs.
- **R-410A Refrigerant** - Environmentally friendly.
- **Scroll Compressors** - Single speed scroll compressor is furnished on all models.
- **High Pressure Switch** - Protects compressor.
- **Belt Drive Blower Motor** - To maximize air performance.
- **Downflow or Horizontal Airflow** - Easy field conversion.
- **Two Fork Lift Slots on Three Sides** - Easy to pick up and transport units from almost any angle.
- **Corrosion-Resistant Drain Pan** - Provides application flexibility, durability, and improved serviceability.
- **Thermostatic Expansion Valve** - Provides peak heating performance across the entire application range.
- **Common Components** - Many maintenance items are standard throughout the entire product line, reducing the need to carry different parts to the job or maintain in inventory.

FEATURES AND BENEFITS

CONTENTS

Blower Data	19
Cooling / Heating Ratings	12
Dimensions - Accessories	43
Dimensions - Unit - ZHA	41
Dimensions - Unit - ZHB	42
Electrical/Electric Heat Data - ZHA	35
Electrical/Electric Heat Data - ZHB	36
Features And Benefits	2
Model Number Identification	1
Optional Conventional Temperature Control Systems	39
Options / Accessories	8
Outdoor Sound Data	37
Specifications - ZHA	10
Specifications - ZHB	11
Unit Clearances	38
Weight Data	40

TESTING

Components bonded for grounding to meet safety standards for servicing required by Underwriters Laboratories (UL) and the International Electrotechnical Commission (IEC).

Cooling performance is rated at test conditions included in Air-Conditioning, Heating and Refrigeration Institute (AHRI) Standards 210/240 (10.5 - 17.5 kW) and 340/360 (21 kW models) while operating at rated voltage and air volumes.

International Organization for Standardization (ISO) 9001 Registered Manufacturing Quality System.

COOLING / HEATING SYSTEM

Designed to maximize sensible and latent cooling performance at design conditions.

System can operate from -18°C to 52°C without any additional controls.

R-410A Refrigerant

Non-chlorine, ozone friendly, R-410A.

Unit is factory pre-charged with refrigerant. See Specifications Table.

1 Compressor

Resiliently mounted on rubber grommets for quiet operation.

Scroll compressors for high performance, reliability and quiet operation.

Compressor Crankcase Heater

Protects against refrigerant migration that can occur during low ambient operation.

Refrigerant Metering Orifice (All ZHA and ZHB036 to 060 models)

Accurately meters refrigerant in system.

Refrigerant control is accomplished by exact sizing of refrigerant metering orifice.

Thermal Expansion Valve (ZHB072 models)

Assures optimal performance throughout the application range. Removable element head.

High Pressure Switch

Protects the compressor from overload conditions such as dirty condenser coils, blocked refrigerant flow, or loss of outdoor fan operation.

Automatic reset.

Reversing Valve

4-way interchange reversing valve effects a rapid change in direction of refrigerant flow resulting in quick changeover from cooling to heating and vice versa.

Defrost Control

Provides a defrost cycle, if needed, every 30 or 60 or 90 minutes (adjustable) of compressor “on” time at outdoor coil temperature below 2°C. Temperature switch mounted on outdoor coil liquid line terminates defrost cycle.

Filter/Drier

High capacity filter/drier protects the system from dirt and moisture.

2 Coil Construction

Copper tube construction, enhanced rippled-edge aluminum fins, flared shoulder tubing connections, silver soldered construction for improved heat transfer. Factory leak tested.

Indoor Coil

Cross row circuiting with rifled tubing optimizes both sensible and latent cooling capacity.

Condensate Drain Pan

Plastic pan, sloped to meet drainage requirements of the American Society of Heating Refrigeration and Air Conditioning Engineers (ASHRAE) 62.1.

End drain connection.

3 Outdoor Coil Fan Motor

Thermal overload protected, totally enclosed, permanently lubricated bearings, shaft down (all ZHA and ZHB036 to 060 models), shaft up (ZHB072) fan guard mount.

FEATURES AND BENEFITS

COOLING / HEATING

SYSTEM (continued)

Outdoor Coil Fan Guard

Polyvinyl chloride (PVC) coated fan guard furnished.

Required Selections

Cooling Capacity

Specify nominal cooling capacity of the unit.

Options/Accessories

Field Installed

Condensate Drain Trap

Field installed only.

Available in copper or polyvinyl chloride (PVC).

Drain Pan Overflow Switch

Monitors condensate level in drain pan, shuts down unit if drain becomes clogged.

Low Ambient Kit

Cycles the outdoor fan while allowing compressor operation in the cooling cycle. This intermittent fan operation allows the system to operate without icing the evaporator coil and losing capacity. Designed for use in ambient temperatures no lower than -18°C.

CABINET

4 Construction

Heavy-gauge steel panels and full perimeter heavy-gauge galvanized steel base rail provides structural integrity for transportation, handling, and installation.

Base rails have rigging holes. Three sides of the base rail have fork slots.

Raised edges around duct and power entry openings in the bottom of the unit provide additional protection against water entering the building.

Airflow Choice

Units are shipped in downflow (vertical) configuration, can be field converted to horizontal airflow configuration without the need of a kit.

5 Power Entry

Electrical lines can be brought through the unit base or through horizontal access knock-outs (end of unit on 036-060 model, side of unit on ZHB072 models).

ZHB072 models feature three mounting locations for the disconnect:

- Side mounting on an adjustable panel (removable corner base rail allows access for installation)
- Side mounting directly over the side power entry knockouts
- End mounting on an adjustable panel (alternate location)

See dimension drawing.

Optional Bottom Power Entry Kit is available.

6 Exterior Panels

Constructed of heavy-gauge, galvanized steel with a two-layer enamel paint finish.

7 Insulation

All panels adjacent to conditioned air are fully insulated with non-hygroscopic fiberglass insulation.

Access Panels

Access panels are provided for the compressor, heating, controls, blower and air filter/economizer section.

Options/Accessories

Factory Installed

Corrosion Protection

A completely flexible immersed coating with an electro-deposited dry film process. (AST ElectroFin E-Coat) Meets Mil Spec MIL-P-53084, ASTM B117 Standard Method Salt Spray Testing.

Indoor Corrosion Protection:

- Coated coil

Outdoor Corrosion Protection:

- Coated coil

Field Installed

Combination Coil/Hail Guards

Heavy gauge steel frame painted to match cabinet with expanded metal mesh to protect the outdoor coil from damage.

FEATURES AND BENEFITS

CONTROLS

Unit Control

All control voltage is provided via a 24V (secondary) transformer with inline fuse protection.

Heat/Cool Staging

Capable of up to 2 heat / 2 cool staging with a thermostat.

Night Setback Mode

Saves energy by closing outdoor air dampers and operating supply fan on thermostat demand only.

Smoke Detectors

NOTE - Smoke detectors are not available and must be field provided by installer.

Options/Accessories

Field Installed

Thermostats

Control system and thermostat options, see page 39.

8 BLOWER

A wide selection of supply air blower options are available to meet a variety of air flow requirements.

Motor

Overload protected, equipped with ball bearings. Belt drive motors are offered on all models and are available in several different sizes to maximize air performance.

Supply Air Blower

Forward curved blades, blower wheel is statically and dynamically balanced.

Equipped with ball bearings and adjustable pulley (allows speed change).

Required Selections

Supply Air Blower

Order blower motor kW and drive kit number required when base unit is ordered, see Drive Kit Specifications Table.

INDOOR AIR QUALITY

Air Filters

Disposable 51 mm filters furnished as standard.

Options/Accessories

Field Installed

Indoor Air Quality (CO₂) Sensor

Monitors CO₂ levels adjusts economizer dampers as needed for Demand Control Ventilation.

ELECTRICAL

Marked & Color-Coded Wiring

All electrical wiring is color-coded and marked to identify which components it is connecting.

Electrical Plugs

Positive connection electrical plugs are used to connect common accessories or maintenance parts for easy removal or installation.

Required Selections

Voltage Choice

Specify when ordering base unit.

Field Installed

Bottom Power Entry Kit

Kit reduces the number of penetrations in the roof.

Kit includes bulkhead connectors to provides power and control wiring routing through the roof curb.

Electric Heat

Helix wound nichrome elements, individual element limit controls, wiring harness. See Options / Accessories tables for ordering information.

NOTE - Unit Fuse Block is required and must be ordered separately. See Electrical/Electric Heat tables for ordering information.

OPTIONS / ACCESSORIES

ECONOMIZER OPTIONS

Factory or Field Installed

Economizer (Downflow or Horizontal) (Standard and High Performance Common Features)

Outdoor Air Hood is furnished.

Economizer includes Barometric Relief Dampers with Exhaust Hood.

Barometric Relief Dampers allow relief of excess air, aluminum blade dampers prevent blow back and outdoor air infiltration during off cycle, bird screen furnished. Hood is furnished.

Single Sensible Temperature Control is furnished with the economizer

Outdoor air sensor enables Economizer if the outdoor temperature is less than the setpoint of the control.

Demand Control Ventilation (DCV) ready using optional CO₂ sensors.

NOTE - Horizontal Economizer is field installed only.

Standard Economizer Features

Gear-driven action, return air and outdoor air dampers, plug-in connections to unit, neoprene seals, 24-volt, fully-modulating spring return motor.

Standard Economizer Control Module

The Standard Economizer Control Module can be adjusted to operate based on outdoor air temperatures.



Economizer Controls:

- Damper Minimum Position - Can be set lower than traditional minimum air requirements resulting in cost savings.
- IAQ Sensor - Signals dampers to modulate and maintain 13°C when CO₂ is higher than the CO₂ setpoint.
- Demand Control Ventilation (DCV) LED - A steady green Demand Control Ventilation LED indicates the IAQ reading is higher than setpoint and requires more fresh air.
- Free Cool LED - A steady green LED indicates outdoor air is suitable for free cooling.

Free Cooling runs when outdoor air temperature is lower than the set temperature on the economizer control.

NOTE: The Free Cooling default setting for outdoor air temperature sensor is 13°C.

High Performance Economizer Features

Gear-driven action, high torque 24-volt fully-modulating spring return damper motor, return air and outdoor air dampers, plug-in connections to unit, nylon bearings, enhanced neoprene blade edge seals and flexible stainless steel jamb seals to minimize air leakage.

High Performance Economizer Control Module

Module provides inputs and outputs to control economizer based on parameter settings.



Module automatically detects sensors by polling to determine which sensors are installed in system.

Module displays any alarm messages (fault detection and diagnostics) as an aid in troubleshooting.

Non-volatile memory retains parameter settings in case of power failure.

Keypad with four navigation buttons and LCD screen is furnished for setting economizer parameters.

- Menu Up/Exit (↑) button returns to the main menu.
- Arrow Up (▲) button moves to the previous or next parameter within the selected menu.
- Arrow Down (▼) button moves to the next parameter within the selected menu.
- Select (enter) (↵) button confirms parameter selection.

Main Menu Structure:

- STATUS (economizer and system operation status)
- SETPOINTS (settings for various setpoint parameters)
- SYSTEM SETUP (settings/information about the system)
- ADVANCED SETUP (freeze protection, CO₂ settings, stage 3 delay and additional calibration settings)
- CHECKOUT (damper positions)
- ALARMS (output signal that can be configured for remote alarm monitoring)

Refer to Installation Instructions for complete setup information and menu parameters available.

Field Installed

Single Enthalpy Temperature Control

Outdoor air enthalpy sensor enables Economizer if the outdoor enthalpy is less than the setpoint of the control.

OPTIONS / ACCESSORIES

EXHAUST OPTIONS

Field Installed

Power Exhaust Fan - Downflow or Horizontal

Installs external to unit for applications with Economizer option. Provides exhaust air pressure relief. Interlocked to run when supply air blower is operating, fan runs when outdoor air dampers are 50% open (adjustable), motor is overload protected.

Fan is 305 mm diameter with 5 fan blades; 0.37 kW motor for 036-072 models.

OUTDOOR AIR OPTIONS

Field Installed

Outdoor Air Dampers - Downflow

Single blade damper, 0 to 25% (fixed) outdoor air adjustable, installs in unit.

Automatic model features fully modulating spring return damper motor with plug-in connection.

Manual model features a slide damper. Maximum mixed air temperature in cooling mode: 38°C.

ROOF CURBS

Hybrid Roof Curbs, Downflow

Nailer strip furnished, mates to unit, US National Roofing Contractors Approved, shipped knocked down.

Roof curb can be assembled using interlocking tabs to fasten corners together. No tools required.

Curb can also be fastened together with furnished hardware.

Available in 203, 356, 457, and 610 mm heights.

Adaptor Curbs (not shown)

Curbs are regionally sourced. Dimensions will vary based upon the source. Contact your local sales representative for a detailed cut sheet with applicable dimensions.

CEILING DIFFUSERS

Ceiling Diffusers (Flush and Step-Down)

Aluminum grilles, large center grille, insulated diffuser box with flanges, hanging rings furnished, interior transition (even air flow), internally sealed (prevents recirculation), adapts to T-bar ceiling grids or plaster ceilings.

Transitions (Supply and Return)

NOTE - Ceiling Diffuser Transitions are not furnished and must be field fabricated.

OPTIONS / ACCESSORIES

Item		Catalog No.	ZHA ZHB 036	ZHA ZHB 048	ZHA ZHB 060	ZHB 072
COOLING SYSTEM						
Condensate Drain Trap	Polyvinyl Chloride (PVC) - C1TRAP20AD2	76W26	X	X	X	X
	Copper - C1TRAP10AD2	76W27	X	X	X	X
Drain Pan Overflow Switch	Z1SNSR90A1	99W59	X	X	X	X
Low Ambient Kit	Z1SNSR34A-1	99W68	X	X	X	X
BLOWER - SUPPLY AIR						
Motors	Belt Drive - 0.62 kW Standard Efficiency	Factory	O	O		
	Belt Drive - 0.93 kW Standard Efficiency	Factory	O	O	O	O
	Belt Drive - 1.24 kW Standard Efficiency	Factory			O	O
Drive Kits See Blower Data Tables for selection	Kit #ZA07 - 705-1077 rev/min	Factory	O			
	Kit #ZA08 - 759-1158 rev/min	Factory		O		
	Kit #ZA09 - 919-1247 rev/min	Factory			O	
	Kit #ZA10 - 1025-1391 rev/min	Factory	O			
	¹ Kit #ZA11 - 1111-1437 rev/min	Factory		O		
	² Kit #ZA12 - 1190-1540 rev/min	Factory			O	
	Kit #ZAA02 - 527-729 rev/min	Factory			O	
	Kit #ZAA03 - 665 -921 rev/min	Factory			O	O
	Kit #ZAA04 - 768-1023 rev/min	Factory			O	O
	Kit #ZAA05 - 921-1177 rev/min	Factory				O
CABINET						
Combination Coil/Hail Guards	ZHA models only - Z1GARD52A-1	12X19	X	X		
	ZHA060 and ZHB models only - Z1GARD20AT1	12X20	X	X	X	
	ZHB072 model only - Z1GARD20AL1	16A41				X
Corrosion Protection		Factory	O	O	O	O
ELECTRICAL						
Voltage 50 hz with neutral	380/420V - 3 phase	Factory	O	O	O	O
Bottom Power Entry Kit	Z1PEKT01A-1	98W08	X	X	X	X
³ ELECTRIC HEAT						
3.8 kW	380/420V-3ph - Z1EH0050AN1G	99W06	X	X	X	
5.7 kW	380/420V-3ph - Z1EH0075AN1G	99W07	X	X	X	X
7.7 kW	380/420V-3ph - Z1EH0100AN1G	99W08	X	X	X	X
11.5 kW	380/420V-3ph - Z1EH0150AN1G	99W09	X	X	X	X
17.2 kW	380/420V-3ph - Z1EH0225AN1G	99W10		X	X	X
23 kW	380/420V-3ph - Z1EH0300A-1G	13U02				X
ELECTRIC HEAT ACCESSORIES						
Unit Fuse Block (required) - See Electrical/Electric Heat Tables for Selection			X	X	X	X

¹ ZA11 drive kits require the 0.93 kW motor.

² ZA12 drive kit requires the 1.24 kW motor.

³ Nominal kW at 420V-3ph-50hz.

NOTE - The catalog and model numbers that appear here are for ordering field installed accessories only.

OX - Field Installed or Configure to Order (factory installed)

O - Configure to Order (factory installed)

X - Field Installed.

OPTIONS / ACCESSORIES

Item	Catalog No.	ZHA ZHB 036	ZHA ZHB 048	ZHA ZHB 060	ZHB 072
ECONOMIZER					
Standard Economizer With Outdoor Air Hood					
Standard Economizer (Downflow) Includes Barometric Relief Dampers and Exhaust Hood	Z1ECON30A-2	14D94	OX	OX	OX
Standard Economizer (Horizontal) Includes Barometric Relief Dampers and Exhaust Hood	Z1ECON16A-2	14D92	X	X	X
Standard Economizer Controls					
Single Enthalpy Control	C1SNSR64FF1	53W64	X	X	X
High Performance Economizer With Outdoor Air Hood					
High Performance Economizer (Downflow) Includes Barometric Relief Dampers and Exhaust Hood	Z1ECON32A-2	14D95	OX	OX	OX
High Performance Economizer (Horizontal) Includes Barometric Relief Dampers and Exhaust Hood	Z1ECON33A-2	14D93	X	X	X
High Performance Economizer Controls					
Single Enthalpy Control	C1SNSR61FF1	11G21	X	X	X
OUTDOOR AIR					
Outdoor Air Dampers - Includes Outdoor Air Hood					
Motorized	Z1DAMP21A-2	15D19	X	X	X
Manual	Z1DAMP11A-2	15D20	X	X	X
POWER EXHAUST FAN					
Standard Static (Downflow)	380/420V-3ph - Z1PWRE10A-1G	23E01	X	X	X
Standard Static (Horizontal)	380/420V-3ph - Z1PWRE15A-1G	28E01	X	X	X
INDOOR AIR QUALITY					
Indoor Air Quality (CO₂) Sensors					
Sensor - Wall-mount, off-white plastic cover with LCD display	C0SNSR50AE1L	77N39	X	X	X
Sensor - Wall-mount, black plastic case, no display, rated for plenum mounting	C0SNSR53AE1L	87N54	X	X	X
CO ₂ Sensor Duct Mounting Kit - for downflow applications	C0MISC19AE1	85L43	X	X	X
Aspiration Box - for duct mounting non-plenum rated CO ₂ sensor (77N39)	C0MISC16AE1	90N43	X	X	X
ROOF CURBS					
Hybrid Roof Curbs, Downflow					
203 mm height	Z1CURB70A-1	11F76	X	X	X
356 mm height	Z1CURB71A-1	11F77	X	X	X
457 mm height	Z1CURB72A-1	11F78	X	X	X
610 mm height	Z1CURB73A-1	11F79	X	X	X
CEILING DIFFUSERS					
Step-Down - Order one	RTD9-65S	13K60	X	X	X
	RTD11-95S	13K61			X
Flush - Order one	FD9-65S	13K55	X	X	X
	FD11-95S	13K56			X

NOTE - Ceiling Diffuser Transitions are not furnished and must be field fabricated.

NOTE - The catalog and model numbers that appear here are for ordering field installed accessories only.

OX - Field Installed or Configure to Order (factory installed)

O - Configure to Order (factory installed)

X - Field Installed.

SPECIFICATIONS - ZHA

General Data		Nominal Size	10.5 kW (3 Ton)	14.0 kW (4 Ton)	17.5 kW (5 Ton)	
		Model No.	ZHA036S4B	ZHA048S4B	ZHA060S4B	
		Efficiency Type	Standard	Standard	Standard	
Cooling Performance	Gross Cooling Capacity - kW (Btuh)		9.6 (32 600)	12.2 (41 700)	15.4 (52 400)	
	¹ Net Cooling Capacity - kW (Btuh)		9.1 (31 200)	11.5 (39 500)	14.7 (50 000)	
	Rated Air Flow - L/s (cfm)		618 (1310)	760 (1610)	916 (1940)	
	² Sound Rating Number (SRN) (dBA) Cooling			79	79	83
		Heating		80	80	83
	Total Unit Power - kW			2.6	3.7	4.5
	¹ SEER (Btuh/Watt)			13.00	13.00	13.00
¹ EER (Btuh/Watt)			11.80	10.80	11.00	
Refrigerant	Type		R-410A	R-410A	R-410A	
	Charge Furnished		5.3 kg (11 lbs. 12 oz.)	5.7 kg (12 lbs. 8 oz.)	6.9 kg (15 lbs. 3 oz.)	
Heating Performance	Total High Heating Capacity - (kW) Btuh		8.5 (29 000)	11.3 (38 500)	14.7 (50 000)	
	Total Unit Power - kW		2.4	3.2	4.1	
	¹ COP		3.52	3.56	3.62	
	Total Low Heating Capacity - (kW) Btuh		5.0 (17 200)	6.9 (23 400)	8.4 (28 600)	
	Total Unit Power - kW		2.3	3.0	3.8	
	COP		2.18	2.28	2.22	
Electric Heat Available - See page 8			3.8, 5.7, 7.7, 11.5 kW	3.8, 5.7, 7.7, 11.5, 17.2 kW		
Compressor Type (one per unit)			Scroll	Scroll	Scroll	
Outdoor Coil	Net face area - m ² (sq. ft.)		4.9 (16.1)	4.9 (16.1)	6.1 (20.1)	
	Tube diameter - mm (in.)		9.5 (3/8)	9.5 (3/8)	9.5 (3/8)	
	Number of rows		2	2	2	
	Fins / meter (inch)		787 (20)	787 (20)	787 (20)	
	Expansion Device Type		Balanced port TXV, removable head			
Outdoor Coil Fan	Motor W (HP)		(1) 190 (1/4)	(1) 190 (1/4)	(1) 250 (1/3)	
	Motor rev/min		688	688	896	
	Total motor watts		229	229	260	
	Diameter - mm (in.)		(1) 559 (22)	(1) 559 (22)	(1) 559 (22)	
	Number of blades		4	4	3	
	Total air volume - L/s (cfm)		1258 (2667)	1258 (2667)	1415 (3000)	
Indoor Coil	Net face area - m ² (sq. ft.)		0.78 (8.4)	0.78 (8.4)	0.89 (9.6)	
	Tube diameter - mm (in.)		9.5 (3/8)	9.5 (3/8)	9.5 (3/8)	
	Number of rows		3	3	3	
	Fins per meter (in.)		551 (14)	551 (14)	551 (14)	
	Drain Connection (no. and size) - in.		(1) 1 NPT	(1) 1 NPT	(1) 1 NPT	
	Expansion device type		Fixed Orifice	Fixed Orifice	Fixed Orifice	
³ Indoor Blower & Drive Selection	Nominal Motor kW (HP)		0.62 kW (0.83 hp), 0.93 kW (1.25 hp)	0.62 kW (0.83 hp), 0.93 kW (1.25 hp)	0.93 kW (1.25 hp), 1.24 kW (1.66 hp)	
	Maximum Usable Motor kW (HP)		0.71 kW (0.95 hp), 1.07 kW (1.43 hp)	0.71 kW (0.95 hp), 1.07 kW (1.43 hp)	1.07 kW (1.43 hp), 1.42 kW (1.91 hp)	
	Available Drive Kits		Kit #ZA07 705-1077 rev/min	Kit #ZA08 759-1158 rev/min	Kit #ZA09 919-1247 rev/min	
			Kit #ZA10 1025-1391 rev/min	⁴ Kit #ZA11 1111-1437 rev/min	⁵ Kit #ZA12 1190-1540 rev/min	
Wheel nominal diameter x width - mm (in.)			254 x 254 (10 x 10)	254 x 254 (10 x 10)	254 x 254 (10 x 10)	
Filters	Type		Disposable			
	Number and size - mm (in.)		(4) 356 x 508 x 51 (14 x 20 x 2)		(4) 406 x 508 x 51 (16 x 20 x 2)	
Electrical Characteristics - 50 Hz			380/420V - 50 hertz - 3 phase with neutral			

NOTE - Net capacity includes evaporator blower motor heat deduction. Gross capacity does not include evaporator blower motor heat deduction.

¹ Rating test conditions are those included in Air-Conditioning, Heating and Refrigeration Institute (AHRI) Standard 210/240 while operating at rated voltage and air volumes;

Cooling Ratings - 35°C (95°F) outdoor air temperature and 26°C (80°F) db/19°C (67°F) wb entering indoor coil air.

High Temperature Heating Ratings - 8°C (47°F) db/6°C (43°F) wb outdoor air temperature and 21°C (70°F) entering indoor coil air.

Low Temperature Heating Ratings - 8°C (17°F) db/-9°C (15°F) wb outdoor air temperature and 21°C (70°F) entering indoor coil air.

² Sound Rating Number (SRN) rated in accordance with test conditions included in ANSI/AHRI Standard 270-2008.

³ Using total air volume and system static pressure requirements determine from blower performance tables rev/min and motor size required. Maximum usable size of motors furnished is shown. If motors of comparable size are used, be sure to keep within the service factor limitations outlined on the motor nameplate.

0.62 kW = 0.83 hp (1.0 nominal hp) while operating at rated voltage and frequency.

0.93 kW = 1.25 hp (1.5 nominal hp) while operating at rated voltage and frequency.

1.24 kW = 1.66 hp (2.0 nominal hp) while operating at rated voltage and frequency.

⁴ ZA11 drive kits require the 0.93 kW motor.

⁵ ZA12 drive kit requires the 1.24 kW motor.

SPECIFICATIONS - ZHB

General Data		Nominal Size	10.5 kW (3 Ton)	14.0 kW (4 Ton)	17.5 kW (5 Ton)	21 kW (6 Ton)
		Model No.	ZHB036S4B	ZHB048S4B	ZHB060S4B	ZHB072S4B
		Efficiency Type	Standard	Standard	Standard	Standard
Cooling Performance	Gross Cooling Capacity - kW (Btuh)		9.1 (31 200)	12.2 (41 700)	15.4 (52 400)	17.9 (61 000)
	Net Cooling Capacity - kW (Btuh)		¹ 8.8 (29 900)	¹ 11.5 (39 500)	¹ 14.7 (50 000)	² 17.3 (59,000)
	Rated Air Flow - L/s (cfm)		595 (1260)	760 (1610)	916 (1940)	877 (1860)
	³ Sound Rating Number (SRN) (dBA) Cooling		79	77	82	86
	Total Unit Power - kW		2.6	3.5	4.3	5.4
	SEER		¹ 14.00	¹ 14.00	¹ 14.00	- - -
	EER (Btuh/Watt)		¹ 11.50	¹ 11.40	¹ 11.30	² 11.10
Refrigerant	Type		R-410A	R-410A	R-410A	R-410A
	Charge Furnished		6.6 kg (14 lbs. 8 oz.)	7.4 kg (16 lbs. 5 oz.)	6.5 kg (14 lbs. 4 oz.)	8.2 kg (18 lbs. 0 oz.)
Heating Performance	Total High Heating Capacity - (kW) Btuh		8.5 (29 100)	11.3 (38 500)	14.7 (50 000)	17.3 (59 000)
	Total Unit Power - kW		2.4	3.1	3.6	4.9
	¹ COP		3.6	3.6	3.7	3.4
	Total Low Heating Capacity - (kW) Btuh		5.2 (17 700)	8.2 (28 800)	10.1 (34 400)	9.7 (33 000)
	Total Unit Power - kW		2.2	3.1	3.5	4.3
			2.3	2.4	2.4	2.3
Electric Heat Available - See page 8			3.8, 5.7, 7.7, 11.5 kW	3.8, 5.7, 7.7, 11.5, 17.2 kW		5.7, 7.7, 11.5, 17.2, 23 kW
Compressor Type (one per unit)			Scroll	Scroll	Scroll	Scroll
Outdoor Coil	Net face area - m ² (sq. ft.)		1.8 (19.9)	1.8 (19.9)	1.8 (19.9)	2.3 (25)
	Tube diameter - mm (in.)		9.5 (3/8)	9.5 (3/8)	9.5 (3/8)	9.5 (3/8)
	Number of rows		2	2	2	2
	Fins / meter (inch)		787 (20)	787 (20)	787 (20)	787 (20)
	Expansion Device Type		Balanced port TXV, removable head			
	Motor W (HP)		(1) 190 (1/4)	(1) 190 (1/4)	(1) 250 (1/3)	(1) 250 (1/3)
Outdoor Coil Fan	Motor rev/min		688	688	896	900
	Total motor watts		229	229	260	266
	Diameter - mm (in.)		(1) 559 (22)	(1) 559 (22)	(1) 559 (22)	(1) 610 (24)
	Number of blades		4	4	3	3
	Total air volume - L/s (cfm)		1574 (3335)	1574 (3335)	1699 (3600)	1770 (3750)
Indoor Coil	Net face area - m ² (sq. ft.)		0.89 (9.6)	1.0 (10.8)	1.0 (10.8)	1.0 (10.8)
	Tube diameter - mm (in.)		9.5 (3/8)	9.5 (3/8)	9.5 (3/8)	9.5 (3/8)
	Number of rows		3	3	3	3
	Fins per meter (in.)		551 (14)	551 (14)	551 (14)	551 (14)
	Drain Connection (no. and size) - in.		(1) 1 NPT	(1) 1 NPT	(1) 1 NPT	(1) 1 NPT
	Expansion device type		Fixed Orifice	Fixed Orifice	Fixed Orifice	Balanced Port TXV, removable power head
⁴ Indoor Blower & Drive Selection	Nominal Motor kW (HP)		0.62 kW (0.83 hp), 0.93 kW (1.25 hp)	0.62 kW (0.83 hp), 0.93 kW (1.25 hp)	0.93 kW (1.25 hp), 1.24 kW (1.66 hp)	0.93 kW (1.25 hp), 1.24 kW (1.66 hp)
	Maximum Usable Motor kW (HP)		0.71 kW (0.95 hp), 1.07 kW (1.43 hp)	0.71 kW (0.95 hp), 1.07 kW (1.43 hp)	1.07 kW (1.43 hp), 1.42 kW (1.91 hp)	1.07 kW (1.43 hp), 1.42 kW (1.91 hp)
	Available Drive Kits		Kit #ZA07	Kit #ZA08	Kit #ZAA02	Kit #ZAA03
			705-1077 rev/min	759-1158 rev/min	527-729 rev/min	665-921 rev/min
			Kit #ZA10 1025-1391 rev/min	⁵ Kit #ZA11 1111-1437 rev/min	Kit #ZAA03 665-921 rev/min Kit #ZAA04 768-1023 rev/min	Kit #ZAA04 768-1023 rev/min Kit #ZAA05 921-1177 rev/min
Wheel nominal diameter x width - mm (in.)			254 x 254 (10 x 10)	254 x 254 (10 x 10)	381 x 229 (15 x 9)	381 x 229 (15 x 9)
Filters	Type		Disposable			
	Number and size - mm (in.)		(4) 406 x 508 x 51 (16 x 20 x 2)	(2) 406 x 508 x 51 (16 x 20 x 2) (2) 508 x 508 x 51 (20 x 20 x 2)		
Electrical Characteristics - 50 Hz			380/420V - 50 hertz - 3 phase with neutral			

NOTE - Net capacity includes evaporator blower motor heat deduction. Gross capacity does not include evaporator blower motor heat deduction.

^{1,2} Rating test conditions are those included in Air-Conditioning, Heating and Refrigeration Institute (AHRI) Standard ¹ 210/240 or ² 340/360 while operating at rated voltage and air volumes;

Cooling Ratings - 35°C (95°F) outdoor air temperature and 26°C (80°F) db/19°C (67°F) wb entering indoor coil air.

High Temperature Heating Ratings - 8°C (47°F) db/6°C (43°F) wb outdoor air temperature and 21°C (70°F) entering indoor coil air.

Low Temperature Heating Ratings - -8°C (17°F) db/-9°C (15°F) wb outdoor air temperature and 21°C (70°F) entering indoor coil air.

³ Sound Rating Number (SRN) rated in accordance with test conditions included in ANSI/AHRI Standard 270-2008.

⁴ Using total air volume and system static pressure requirements determine from blower performance tables rev/min and motor size required. Maximum usable size of motors furnished is shown. If motors of comparable size are used, be sure to keep within the service factor limitations outlined on the motor nameplate.

0.62 kW = 0.83 hp (1.0 nominal hp) while operating at rated voltage and frequency.

0.93 kW = 1.25 hp (1.5 nominal hp) while operating at rated voltage and frequency.

1.24 kW = 1.66 hp (2.0 nominal hp) while operating at rated voltage and frequency.

⁵ ZA11 drive kits require the 0.93 kW motor.

COOLING / HEATING RATINGS

NOTE – For Temperatures and Capacities not shown in tables, see bulletin – Cooling Unit Rating Table Correction Factor Data in Miscellaneous Engineering Data section.

10.5 kW - ZHA036S4 - COOLING CAPACITY

Entering Wet Bulb Temperature	Total Air Volume	Outdoor Air Temperature Entering Outdoor Coil																			
		26.7°C					35°C					43.3°C					51.7°C				
		Total Cool Cap.	Comp. Motor Input	Sensible To Total Ratio (S/T)			Total Cool Cap.	Comp. Motor Input	Sensible To Total Ratio (S/T)			Total Cool Cap.	Comp. Motor Input	Sensible To Total Ratio (S/T)			Total Cool Cap.	Comp. Motor Input	Sensible To Total Ratio (S/T)		
				Dry Bulb					Dry Bulb					Dry Bulb					Dry Bulb		
L/s	kW	kW	24°C	27°C	29°C	kW	kW	24°C	27°C	29°C	kW	kW	24°C	27°C	29°C	kW	kW	24°C	27°C	29°C	
17.2°C	455	9.1	1.59	0.77	0.93	1.00	8.6	1.95	0.79	0.95	1.00	7.7	2.36	0.83	1.00	1.00	6.4	2.79	0.93	1.00	1.00
	565	9.6	1.59	0.83	1.00	1.00	9.0	1.95	0.86	1.00	1.00	8.3	2.37	0.91	1.00	1.00	6.7	2.80	1.00	1.00	1.00
	680	10.1	1.60	0.90	1.00	1.00	9.5	1.96	0.93	1.00	1.00	8.6	2.38	0.98	1.00	1.00	7.0	2.81	1.00	1.00	1.00
19.4°C	455	9.7	1.59	0.60	0.75	0.89	9.1	1.96	0.61	0.77	0.92	8.2	2.37	0.63	0.81	0.97	6.5	2.80	0.69	0.91	1.00
	565	10.1	1.60	0.64	0.81	0.98	9.4	1.96	0.66	0.84	1.00	8.5	2.38	0.68	0.89	1.00	6.8	2.81	0.76	1.00	1.00
	680	10.4	1.60	0.68	0.88	1.00	9.7	1.97	0.70	0.91	1.00	8.7	2.38	0.73	0.97	1.00	7.0	2.81	0.83	1.00	1.00
21.7°C	455	10.2	1.60	0.44	0.59	0.72	9.6	1.97	0.45	0.60	0.75	8.6	2.38	0.46	0.62	0.78	6.9	2.81	0.48	0.69	0.88
	565	10.7	1.60	0.47	0.63	0.79	10.0	1.97	0.47	0.65	0.82	8.9	2.39	0.48	0.68	0.87	7.1	2.82	0.51	0.76	0.99
	680	11.0	1.61	0.48	0.67	0.86	10.2	1.98	0.49	0.69	0.89	9.1	2.40	0.50	0.73	0.95	7.2	2.82	0.54	0.83	1.00

Entering Wet Bulb Temperature	Total Air Volume	Outdoor Air Temperature Entering Outdoor Coil														
		46°C					48°C					50°C				
		Total Cool Cap.	Comp. Motor Input	Sensible To Total Ratio (S/T)			Total Cool Cap.	Comp. Motor Input	Sensible To Total Ratio (S/T)			Total Cool Cap.	Comp. Motor Input	Sensible To Total Ratio (S/T)		
				Dry Bulb					Dry Bulb					Dry Bulb		
L/s	kW	kW	24°C	27°C	29°C	kW	kW	24°C	27°C	29°C	kW	kW	24°C	27°C	29°C	
17.2°C	455	7.6	2.50	0.85	1.00	1.00	25.8	7.6	2.50	0.85	1.00	1.00	2.71	0.90	1.00	1.00
	565	8.0	2.51	0.94	1.00	1.00	27.3	8.0	2.51	0.94	1.00	1.00	2.72	0.99	1.00	1.00
	680	8.4	2.52	1.00	1.00	1.00	28.4	8.3	2.52	1.00	1.00	1.00	2.73	1.00	1.00	1.00
19.4°C	455	7.9	2.51	0.65	0.83	1.00	27.0	7.9	2.51	0.65	0.83	1.00	2.71	0.67	0.88	1.00
	565	8.2	2.51	0.70	0.92	1.00	27.8	8.1	2.52	0.71	0.92	1.00	2.72	0.74	0.98	1.00
	680	8.4	2.52	0.76	1.00	1.00	28.5	8.4	2.52	0.76	0.99	1.00	2.73	0.80	1.00	1.00
21.7°C	455	8.3	2.52	0.47	0.64	0.81	28.3	8.3	2.52	0.47	0.64	0.81	2.72	0.47	0.67	0.86
	565	8.6	2.52	0.49	0.70	0.90	29.2	8.6	2.53	0.50	0.70	0.90	2.73	0.50	0.73	0.96
	680	8.8	2.53	0.52	0.76	0.98	29.8	8.7	2.53	0.52	0.76	0.98	2.73	0.53	0.80	1.00

10.5 kW - ZHA036S4 - HEATING CAPACITY

Indoor Coil Air Volume 21°C Dry Bulb	Air Temperature Entering Outdoor Coil									
	18°C		7°C		-4°C		-15°C		-26°C	
	Total Heating Capacity	Comp. Motor Input	Total Heating Capacity	Comp. Motor Input	Total Heating Capacity	Comp. Motor Input	Total Heating Capacity	Comp. Motor Input	Total Heating Capacity	Comp. Motor Input
L/s	kW	kW	kW	kW	kW	kW	kW	kW	kW	kW
453	10.5	1.95	8.1	1.86	5.7	1.76	3.7	1.60	1.9	1.19
566	10.6	1.84	8.2	1.75	5.8	1.65	3.8	1.49	2.0	1.08
680	10.6	1.79	8.3	1.69	5.9	1.60	3.9	1.44	2.1	1.03

COOLING / HEATING RATINGS

NOTE – For Temperatures and Capacities not shown in tables, see bulletin – Cooling Unit Rating Table Correction Factor Data in Miscellaneous Engineering Data section.

14.0 KW - ZHA048S4 - COOLING CAPACITY

Entering Wet Bulb Temperature	Total Air Volume	Outdoor Air Temperature Entering Outdoor Coil																			
		26.7°C					35°C					43.3°C					51.7°C				
		Total Cool Cap.	Comp. Motor Input	Sensible To Total Ratio (S/T)			Total Cool Cap.	Comp. Motor Input	Sensible To Total Ratio (S/T)			Total Cool Cap.	Comp. Motor Input	Sensible To Total Ratio (S/T)			Total Cool Cap.	Comp. Motor Input	Sensible To Total Ratio (S/T)		
				Dry Bulb					Dry Bulb					Dry Bulb					Dry Bulb		
L/s	kW	kW	24°C	27°C	29°C	kW	kW	24°C	27°C	29°C	kW	kW	24°C	27°C	29°C	kW	kW	24°C	27°C	29°C	
17.2°C	605	12.5	2.34	0.77	0.93	1.00	10.6	2.81	0.79	0.97	1.00	8.8	3.41	0.81	1.00	1.00	6.9	4.18	0.88	1.00	1.00
	755	13.3	2.35	0.84	1.00	1.00	11.5	2.83	0.87	1.00	1.00	9.7	3.44	0.92	1.00	1.00	7.6	4.21	0.99	1.00	1.00
	905	14.1	2.37	0.91	1.00	1.00	12.3	2.85	0.94	1.00	1.00	10.4	3.46	0.99	1.00	1.00	8.2	4.23	1.00	1.00	1.00
19.4°C	605	13.5	2.35	0.58	0.75	0.90	11.5	2.83	0.57	0.77	0.94	9.6	3.43	0.56	0.79	0.98	7.3	4.19	0.55	0.86	1.00
	755	14.2	2.37	0.63	0.82	0.98	12.2	2.85	0.63	0.85	1.00	10.1	3.45	0.64	0.90	1.00	7.8	4.21	0.65	0.97	1.00
	905	14.7	2.38	0.68	0.89	1.00	12.7	2.86	0.69	0.93	1.00	10.5	3.47	0.71	0.98	1.00	8.3	4.23	0.75	1.00	1.00
21.7°C	605	14.5	2.37	0.42	0.58	0.73	12.5	2.86	0.39	0.57	0.75	10.5	3.46	0.35	0.57	0.77	8.1	4.22	0.29	0.57	0.84
	755	15.2	2.39	0.45	0.63	0.81	13.2	2.87	0.42	0.63	0.83	11.0	3.48	0.39	0.64	0.88	8.6	4.25	0.34	0.67	0.95
	905	15.8	2.41	0.47	0.67	0.87	13.7	2.89	0.45	0.69	0.91	11.4	3.50	0.42	0.71	0.96	8.9	4.26	0.39	0.76	1.00

Entering Wet Bulb Temperature	Total Air Volume	Outdoor Air Temperature Entering Outdoor Coil														
		46°C					48°C					50°C				
		Total Cool Cap.	Comp. Motor Input	Sensible To Total Ratio (S/T)			Total Cool Cap.	Comp. Motor Input	Sensible To Total Ratio (S/T)			Total Cool Cap.	Comp. Motor Input	Sensible To Total Ratio (S/T)		
				Dry Bulb					Dry Bulb					Dry Bulb		
L/s	kW	kW	24°C	27°C	29°C	kW	kW	24°C	27°C	29°C	kW	kW	24°C	27°C	29°C	
17.2°C	605	8.2	3.63	0.81	1.00	1.00	27.9	8.2	3.64	0.81	1.00	1.00	4.01	0.86	1.00	1.00
	755	9.1	3.66	0.93	1.00	1.00	31.0	9.1	3.67	0.93	1.00	1.00	4.04	0.97	1.00	1.00
	905	9.8	3.68	1.00	1.00	1.00	33.3	9.8	3.69	1.00	1.00	1.00	4.06	1.00	1.00	1.00
19.4°C	605	8.9	3.65	0.55	0.79	1.00	30.3	8.9	3.66	0.55	0.79	1.00	4.03	0.58	0.84	1.00
	755	9.4	3.67	0.63	0.90	1.00	32.0	9.4	3.68	0.63	0.91	1.00	4.04	0.65	0.96	1.00
	905	9.8	3.68	0.70	0.99	1.00	33.4	9.8	3.69	0.70	0.99	1.00	4.06	0.74	1.00	1.00
21.7°C	605	9.8	3.68	0.33	0.55	0.77	33.3	9.8	3.69	0.33	0.55	0.77	4.06	0.30	0.56	0.82
	755	10.3	3.70	0.37	0.63	0.88	35.1	10.3	3.71	0.37	0.63	0.88	4.08	0.35	0.66	0.93
	905	10.7	3.72	0.41	0.71	0.97	36.2	10.6	3.72	0.41	0.71	0.98	4.10	0.40	0.75	1.00

14.0 KW - ZHA048S4 - HEATING CAPACITY

Indoor Coil Air Volume 21°C Dry Bulb	Air Temperature Entering Outdoor Coil									
	18°C		7°C		-4°C		-15°C		-26°C	
	Total Heating Capacity	Comp. Motor Input	Total Heating Capacity	Comp. Motor Input	Total Heating Capacity	Comp. Motor Input	Total Heating Capacity	Comp. Motor Input	Total Heating Capacity	Comp. Motor Input
L/s	kW	kW	kW	kW	kW	kW	kW	kW	kW	kW
604	13.7	2.56	10.6	2.44	7.5	2.31	5.0	2.12	2.5	1.57
755	13.9	2.43	10.8	2.31	7.7	2.18	5.2	1.99	2.7	1.44
906	14.1	2.36	11.0	2.24	7.9	2.11	5.4	1.92	2.9	1.37

COOLING / HEATING RATINGS

NOTE – For Temperatures and Capacities not shown in tables, see bulletin – Cooling Unit Rating Table Correction Factor Data in Miscellaneous Engineering Data section.

17.5 KW - ZHA060S4 - COOLING CAPACITY

Entering Wet Bulb Temperature	Total Air Volume	Outdoor Air Temperature Entering Outdoor Coil																			
		26.7°C					35°C					43.3°C					51.7°C				
		Total Cool Cap.	Comp. Motor Input	Sensible To Total Ratio (S/T)			Total Cool Cap.	Comp. Motor Input	Sensible To Total Ratio (S/T)			Total Cool Cap.	Comp. Motor Input	Sensible To Total Ratio (S/T)			Total Cool Cap.	Comp. Motor Input	Sensible To Total Ratio (S/T)		
				Dry Bulb					Dry Bulb					Dry Bulb					Dry Bulb		
L/s	kW	kW	24°C	27°C	29°C	kW	kW	24°C	27°C	29°C	kW	kW	24°C	27°C	29°C	kW	kW	24°C	27°C	29°C	
17.2°C	755	15.6	2.89	0.77	0.93	1.00	13.5	3.46	0.79	0.96	1.00	11.3	4.19	0.82	1.00	1.00	9.2	5.18	0.87	1.00	1.00
	944	16.5	2.91	0.84	1.00	1.00	14.6	3.49	0.87	1.00	1.00	12.4	4.23	0.91	1.00	1.00	10.2	5.23	0.98	1.00	1.00
	1133	17.6	2.93	0.90	1.00	1.00	15.6	3.51	0.94	1.00	1.00	13.3	4.26	0.99	1.00	1.00	11.0	5.26	1.00	1.00	1.00
19.4°C	755	16.8	2.91	0.58	0.75	0.90	14.7	3.49	0.58	0.76	0.93	12.3	4.22	0.57	0.80	0.98	9.8	5.20	0.57	0.85	1.00
	944	17.7	2.93	0.63	0.82	0.98	15.5	3.51	0.63	0.85	1.00	12.9	4.24	0.64	0.90	1.00	10.4	5.23	0.66	0.96	1.00
	1133	18.4	2.95	0.68	0.89	1.00	16.1	3.53	0.68	0.92	1.00	13.4	4.26	0.71	0.97	1.00	11.0	5.26	0.74	1.00	1.00
21.7°C	755	18.0	2.94	0.42	0.58	0.73	15.9	3.52	0.40	0.57	0.74	13.4	4.26	0.37	0.57	0.77	10.8	5.25	0.32	0.58	0.82
	944	19.0	2.96	0.45	0.63	0.80	16.7	3.54	0.43	0.63	0.83	14.0	4.28	0.40	0.64	0.88	11.4	5.28	0.37	0.67	0.94
	1133	19.7	2.97	0.47	0.67	0.87	17.2	3.56	0.45	0.68	0.90	14.6	4.30	0.44	0.71	0.95	11.8	5.31	0.41	0.75	1.00

Entering Wet Bulb Temperature	Total Air Volume	Outdoor Air Temperature Entering Outdoor Coil														
		46°C					48°C					50°C				
		Total Cool Cap.	Comp. Motor Input	Sensible To Total Ratio (S/T)			Total Cool Cap.	Comp. Motor Input	Sensible To Total Ratio (S/T)			Total Cool Cap.	Comp. Motor Input	Sensible To Total Ratio (S/T)		
				Dry Bulb					Dry Bulb					Dry Bulb		
L/s	kW	kW	24°C	27°C	29°C	kW	kW	24°C	27°C	29°C	kW	kW	24°C	27°C	29°C	
17.2°C	755	14.1	4.47	0.86	1.00	1.00	14.1	4.47	0.86	1.00	1.00	9.6	4.95	0.86	1.00	1.00
	945	14.9	4.52	0.94	1.00	1.00	14.9	4.52	0.94	1.00	1.00	10.6	4.99	0.96	1.00	1.00
	1135	15.6	4.54	1.00	1.00	1.00	15.6	4.54	1.00	1.00	1.00	11.4	5.03	1.00	1.00	1.00
19.4°C	755	14.7	4.50	0.66	0.84	1.00	14.7	4.50	0.66	0.84	1.00	10.3	4.97	0.57	0.83	1.00
	945	15.2	4.53	0.71	0.92	1.00	15.2	4.53	0.71	0.92	1.00	10.9	5.00	0.65	0.94	1.00
	1135	15.6	4.55	0.76	0.99	1.00	15.6	4.55	0.76	0.99	1.00	11.4	5.03	0.74	1.00	1.00
21.7°C	755	15.5	4.54	0.47	0.65	0.81	15.5	4.54	0.47	0.65	0.81	11.3	5.02	0.33	0.58	0.81
	945	16.1	4.57	0.50	0.70	0.90	16.1	4.57	0.50	0.70	0.90	12.0	5.05	0.38	0.66	0.92
	1135	16.4	4.59	0.52	0.76	0.98	16.4	4.59	0.52	0.76	0.98	12.3	5.07	0.42	0.74	1.00

17.5 KW - ZHA060S4 - COOLING CAPACITY

Indoor Coil Air Volume 70°F Dry Bulb	Air Temperature Entering Outdoor Coil									
	18°C		7°C		-4°C		-15°C		-26°C	
	Total Heating Capacity	Comp. Motor Input	Total Heating Capacity	Comp. Motor Input	Total Heating Capacity	Comp. Motor Input	Total Heating Capacity	Comp. Motor Input	Total Heating Capacity	Comp. Motor Input
L/s	kW	kW	kW	kW	kW	kW	kW	kW	kW	kW
755	18.3	3.31	13.8	3.12	9.2	2.92	5.9	2.64	3.0	1.95
944	18.5	3.18	14.0	2.98	9.4	2.79	6.2	2.50	3.3	1.81
1133	18.7	3.11	14.2	2.92	9.6	2.72	6.3	2.43	3.4	1.74

COOLING / HEATING RATINGS

NOTE – For Temperatures and Capacities not shown in tables, see bulletin – Cooling Unit Rating Table Correction Factor Data in Miscellaneous Engineering Data section.

10.5 kW - ZHB036S4 - COOLING CAPACITY

Entering Wet Bulb Temperature	Total Air Volume	Outdoor Air Temperature Entering Outdoor Coil																			
		26.7°C					35°C					43.3°C					51.7°C				
		Total Cool Cap.	Comp. Motor Input	Sensible To Total Ratio (S/T)			Total Cool Cap.	Comp. Motor Input	Sensible To Total Ratio (S/T)			Total Cool Cap.	Comp. Motor Input	Sensible To Total Ratio (S/T)			Total Cool Cap.	Comp. Motor Input	Sensible To Total Ratio (S/T)		
				Dry Bulb					Dry Bulb					Dry Bulb					Dry Bulb		
L/s	kW	kW	24°C	27°C	29°C	kW	kW	24°C	27°C	29°C	kW	kW	24°C	27°C	29°C	kW	kW	24°C	27°C	29°C	
17.2°C	455	9.2	1.66	0.74	0.91	1.00	8.0	1.99	0.76	0.96	1.00	6.8	2.40	0.79	1.00	1.00	5.6	2.92	0.85	1.00	1.00
	565	9.8	1.66	0.81	1.00	1.00	8.7	2.00	0.84	1.00	1.00	7.5	2.41	0.90	1.00	1.00	6.2	2.93	1.00	1.00	1.00
	680	10.4	1.68	0.89	1.00	1.00	9.2	2.01	0.94	1.00	1.00	8.0	2.41	1.00	1.00	1.00	6.6	2.94	1.00	1.00	1.00
19.4°C	455	9.9	1.66	0.56	0.72	0.88	8.6	2.00	0.56	0.74	0.92	7.3	2.41	0.56	0.77	0.99	5.9	2.93	0.56	0.82	1.00
	565	10.4	1.68	0.61	0.79	0.98	9.1	2.00	0.61	0.82	1.00	7.7	2.42	0.62	0.88	1.00	6.2	2.93	0.65	0.97	1.00
	680	10.8	1.68	0.65	0.87	1.00	9.4	2.01	0.66	0.91	1.00	8.0	2.42	0.69	0.98	1.00	6.6	2.94	0.73	1.00	1.00
21.7°C	455	10.6	1.68	0.41	0.55	0.70	9.3	2.01	0.39	0.55	0.72	8.0	2.42	0.36	0.56	0.75	6.5	2.93	0.33	0.56	0.80
	565	11.2	1.69	0.43	0.60	0.77	9.8	2.02	0.41	0.61	0.80	8.4	2.43	0.40	0.62	0.85	6.9	2.94	0.37	0.65	0.94
	680	11.5	1.70	0.45	0.65	0.84	10.2	2.02	0.44	0.66	0.89	8.7	2.43	0.43	0.69	0.96	7.1	2.93	0.41	0.73	1.00

Entering Wet Bulb Temperature	Total Air Volume	Outdoor Air Temperature Entering Outdoor Coil														
		46°C					48°C					50°C				
		Total Cool Cap.	Comp. Motor Input	Sensible To Total Ratio (S/T)			Total Cool Cap.	Comp. Motor Input	Sensible To Total Ratio (S/T)			Total Cool Cap.	Comp. Motor Input	Sensible To Total Ratio (S/T)		
				Dry Bulb					Dry Bulb					Dry Bulb		
L/s	kW	kW	24°C	27°C	29°C	kW	kW	24°C	27°C	29°C	kW	kW	24°C	27°C	29°C	
17.2°C	455	6.4	2.55	0.82	1.00	1.00	6.1	2.68	0.82	1.00	1.00	5.8	2.81	0.83	1.00	1.00
	565	7.1	2.56	0.94	1.00	1.00	6.8	2.69	0.95	1.00	1.00	6.4	2.81	0.97	1.00	1.00
	680	7.6	2.57	1.00	1.00	1.00	7.2	2.69	1.00	1.00	1.00	6.9	2.83	1.00	1.00	1.00
19.4°C	455	6.9	2.56	0.57	0.80	1.00	6.5	2.69	0.56	0.79	1.00	6.2	2.82	0.56	0.81	1.00
	565	7.3	2.56	0.64	0.91	1.00	6.9	2.69	0.64	0.92	1.00	6.5	2.81	0.64	0.94	1.00
	680	7.6	2.56	0.71	1.00	1.00	7.2	2.69	0.71	1.00	1.00	6.9	2.82	0.72	1.00	1.00
21.7°C	455	7.5	2.57	0.36	0.57	0.77	7.2	2.69	0.34	0.56	0.77	6.8	2.81	0.34	0.56	0.78
	565	7.9	2.57	0.39	0.64	0.89	7.5	2.70	0.38	0.64	0.89	7.2	2.82	0.38	0.64	0.91
	680	8.2	2.58	0.43	0.72	0.98	7.8	2.70	0.42	0.71	1.00	7.4	2.83	0.42	0.72	1.00

10.5 kW - ZHB036S4 - HEATING CAPACITY

Indoor Coil Air Volume 21°C Dry Bulb	Air Temperature Entering Outdoor Coil									
	18°C		7°C		-4°C		-15°C		-26°C	
	Total Heating Capacity	Comp. Motor Input	Total Heating Capacity	Comp. Motor Input	Total Heating Capacity	Comp. Motor Input	Total Heating Capacity	Comp. Motor Input	Total Heating Capacity	Comp. Motor Input
L/s	kW	kW	kW	kW	kW	kW	kW	kW	kW	kW
453	10.3	1.93	8.0	1.86	5.6	1.78	3.8	1.64	1.9	1.21
566	10.5	1.83	8.2	1.76	5.8	1.68	3.9	1.54	2.0	1.11
680	10.6	1.78	8.3	1.71	5.9	1.64	4.0	1.49	2.2	1.06

COOLING / HEATING RATINGS

NOTE – For Temperatures and Capacities not shown in tables, see bulletin – Cooling Unit Rating Table Correction Factor Data in Miscellaneous Engineering Data section.

14.0 KW - ZHB048S4 - COOLING CAPACITY

Entering Wet Bulb Temperature	Total Air Volume	Outdoor Air Temperature Entering Outdoor Coil																							
		26.7°C						35°C						43.3°C						51.7°C					
		Total Cool Cap.	Comp. Motor Input	Sensible To Total Ratio (S/T)			Total Cool Cap.	Comp. Motor Input	Sensible To Total Ratio (S/T)			Total Cool Cap.	Comp. Motor Input	Sensible To Total Ratio (S/T)			Total Cool Cap.	Comp. Motor Input	Sensible To Total Ratio (S/T)						
				Dry Bulb					Dry Bulb					Dry Bulb					Dry Bulb						
L/s	kW	kW	24°C	27°C	29°C	kW	kW	24°C	27°C	29°C	kW	kW	24°C	27°C	29°C	kW	kW	24°C	27°C	29°C					
17.2°C	605	12.1	2.28	0.73	0.90	1.00	10.7	2.76	0.74	0.95	1.00	9.1	3.36	0.8	1.00	1.00	7.5	4.11	0.84	1.00	1.00				
	755	12.9	2.28	0.79	1.00	1.00	11.5	2.78	0.82	1.00	1.00	10	3.37	0.9	1.00	1.00	8.2	4.12	0.98	1.00	1.00				
	905	13.7	2.29	0.87	1.00	1.00	12.2	2.78	0.92	1.00	1.00	10.7	3.39	1.0	1.00	1.00	8.8	4.14	1.00	1.00	1.00				
19.4°C	605	13.0	2.28	0.56	0.71	0.86	11.5	2.78	0.55	0.72	0.91	9.8	3.36	0.6	0.75	0.97	7.9	4.12	0.56	0.81	1.00				
	755	13.7	2.28	0.60	0.77	0.97	12.1	2.79	0.61	0.80	1.00	10.3	3.37	0.6	0.85	1.00	8.4	4.14	0.64	0.95	1.00				
	905	14.2	2.28	0.64	0.84	1.00	12.5	2.78	0.65	0.89	1.00	10.8	3.39	0.7	0.96	1.00	8.8	4.13	0.72	1.00	1.00				
21.7°C	605	13.9	2.28	0.41	0.55	0.68	12.3	2.79	0.38	0.55	0.70	10.7	3.38	0.4	0.55	0.73	8.6	4.12	0.34	0.56	0.78				
	755	14.6	2.29	0.43	0.59	0.75	13.0	2.80	0.41	0.60	0.78	11.2	3.39	0.4	0.61	0.83	9.1	4.13	0.38	0.64	0.92				
	905	15.1	2.29	0.45	0.64	0.82	13.4	2.79	0.44	0.65	0.86	11.5	3.41	0.4	0.67	0.93	9.4	4.13	0.42	0.72	1.00				

Entering Wet Bulb Temperature	Total Air Volume	Outdoor Air Temperature Entering Outdoor Coil																	
		46°C						48°C						50°C					
		Total Cool Cap.	Comp. Motor Input	Sensible To Total Ratio (S/T)			Total Cool Cap.	Comp. Motor Input	Sensible To Total Ratio (S/T)			Total Cool Cap.	Comp. Motor Input	Sensible To Total Ratio (S/T)					
				Dry Bulb					Dry Bulb					Dry Bulb					
L/s	kW	kW	24°C	27°C	29°C	kW	kW	24°C	27°C	29°C	kW	kW	24°C	27°C	29°C				
17.2°C	605	8.6	3.58	0.81	1.00	1.00	8.30	3.76	0.80	1.00	1.00	7.90	3.95	0.82	1.00	1.00			
	755	9.5	3.59	0.92	1.00	1.00	9.10	3.77	0.93	1.00	1.00	8.60	3.96	0.96	1.00	1.00			
	905	10.1	3.61	1.00	1.00	1.00	9.70	3.79	1.00	1.00	1.00	9.20	3.98	1.00	1.00	1.00			
19.4°C	605	9.3	3.59	0.57	0.79	0.99	8.80	3.77	0.56	0.78	1.00	8.30	3.95	0.56	0.79	1.00			
	755	9.8	3.59	0.63	0.89	1.00	9.30	3.77	0.63	0.90	1.00	8.80	3.96	0.63	0.93	1.00			
	905	10.2	3.61	0.70	0.99	1.00	9.70	3.78	0.69	1.00	1.00	9.20	3.95	0.71	1.00	1.00			
21.7°C	605	10.1	3.59	0.36	0.56	0.76	9.60	3.78	0.35	0.56	0.76	9.10	3.97	0.34	0.56	0.77			
	755	10.6	3.61	0.40	0.64	0.87	10.10	3.78	0.38	0.63	0.87	9.50	3.97	0.38	0.64	0.89			
	905	10.9	3.62	0.43	0.70	0.96	10.40	3.80	0.42	0.70	0.98	9.80	3.99	0.42	0.71	1.00			

14.0 KW - ZHB048S4 - HEATING CAPACITY

Indoor Coil Air Volume 21°C Dry Bulb	Air Temperature Entering Outdoor Coil									
	18°C		7°C		-4°C		-15°C		-26°C	
	Total Heating Capacity	Comp. Motor Input	Total Heating Capacity	Comp. Motor Input	Total Heating Capacity	Comp. Motor Input	Total Heating Capacity	Comp. Motor Input	Total Heating Capacity	Comp. Motor Input
L/s	kW	kW	kW	kW	kW	kW	kW	kW	kW	kW
604	12.8	2.76	10.9	2.48	9.1	2.19	6.5	1.93	3.1	1.46
755	13	2.61	11.1	2.33	9.3	2.04	6.7	1.78	3.3	1.31
906	13.2	2.52	11.3	2.24	9.6	1.95	6.9	1.69	3.5	1.22

COOLING / HEATING RATINGS

NOTE – For Temperatures and Capacities not shown in tables, see bulletin – Cooling Unit Rating Table Correction Factor Data in Miscellaneous Engineering Data section.

17.5 KW - ZHB060S4 - COOLING CAPACITY

Entering Wet Bulb Temperature	Total Air Volume	Outdoor Air Temperature Entering Outdoor Coil																			
		26.7°C					35°C					43.3°C					51.7°C				
		Total Cool Cap.	Comp. Motor Input	Sensible To Total Ratio (S/T)			Total Cool Cap.	Comp. Motor Input	Sensible To Total Ratio (S/T)			Total Cool Cap.	Comp. Motor Input	Sensible To Total Ratio (S/T)			Total Cool Cap.	Comp. Motor Input	Sensible To Total Ratio (S/T)		
				Dry Bulb					Dry Bulb					Dry Bulb					Dry Bulb		
L/s	kW	kW	24°C	27°C	29°C	kW	kW	24°C	27°C	29°C	kW	kW	24°C	27°C	29°C	kW	kW	24°C	27°C	29°C	
17.2°C	755	15.2	2.83	0.7	0.92	1.00	12.5	3.40	0.73	0.95	1.00	9.8	4.14	0.74	1.00	1.00	7.1	5.11	0.78	1.00	1.00
	944	16.5	2.85	0.8	1.00	1.00	13.9	3.42	0.83	1.00	1.00	11.3	4.16	0.87	1.00	1.00	8.3	5.15	0.96	1.00	1.00
	1133	17.8	2.87	0.9	1.00	1.00	15.1	3.44	0.92	1.00	1.00	12.3	4.20	0.98	1.00	1.00	9.3	5.19	1.00	1.00	1.00
19.4°C	755	16.7	2.85	0.5	0.71	0.88	14.0	3.42	0.51	0.71	0.91	11.0	4.17	0.47	0.73	0.97	7.8	5.11	0.39	0.76	1.00
	944	17.8	2.87	0.6	0.79	0.97	14.9	3.44	0.58	0.81	1.00	11.8	4.17	0.56	0.85	1.00	8.6	5.15	0.53	0.93	1.00
	1133	18.6	2.88	0.6	0.86	1.00	15.6	3.45	0.63	0.89	1.00	12.5	4.20	0.63	0.96	1.00	9.3	5.18	0.63	1.00	1.00
21.7°C	755	18.3	2.87	0.4	0.54	0.69	15.4	3.45	0.33	0.52	0.70	12.4	4.19	0.25	0.49	0.71	9.1	5.16	0.12	0.44	0.74
	944	19.4	2.89	0.4	0.59	0.77	16.4	3.46	0.37	0.58	0.79	13.2	4.21	0.30	0.57	0.83	9.7	5.19	0.19	0.56	0.90
	1133	20.1	2.90	0.4	0.64	0.84	17.0	3.47	0.40	0.64	0.87	13.8	4.23	0.35	0.64	0.93	10.3	5.22	0.26	0.66	1.00

Entering Wet Bulb Temperature	Total Air Volume	Outdoor Air Temperature Entering Outdoor Coil														
		46°C					48°C					50°C				
		Total Cool Cap.	Comp. Motor Input	Sensible To Total Ratio (S/T)			Total Cool Cap.	Comp. Motor Input	Sensible To Total Ratio (S/T)			Total Cool Cap.	Comp. Motor Input	Sensible To Total Ratio (S/T)		
				Dry Bulb					Dry Bulb					Dry Bulb		
L/s	kW	kW	24°C	27°C	29°C	kW	kW	24°C	27°C	29°C	kW	kW	24°C	27°C	29°C	
17.2°C	755	9.0	4.42	0.75	1.00	1.00	8.3	4.65	0.76	1.00	1.00	7.60	4.90	0.76	1.00	1.00
	945	10.3	4.44	0.90	1.00	1.00	9.6	4.69	0.92	1.00	1.00	8.90	4.93	0.94	1.00	1.00
	1135	11.4	4.48	1.00	1.00	1.00	10.6	4.71	1.00	1.00	1.00	9.90	4.96	1.00	1.00	1.00
19.4°C	755	10.0	4.44	0.45	0.74	1.00	9.2	4.68	0.43	0.74	1.00	8.40	4.90	0.41	0.75	1.00
	945	10.8	4.45	0.55	0.87	1.00	10.0	4.70	0.54	0.89	1.00	9.20	4.94	0.53	0.91	1.00
	1135	11.5	4.48	0.63	0.98	1.00	10.7	4.72	0.63	1.00	1.00	9.90	4.96	0.63	1.00	1.00
21.7°C	755	11.4	4.48	0.22	0.47	0.72	10.6	4.72	0.19	0.46	0.73	9.70	4.94	0.15	0.45	0.73
	945	12.1	4.49	0.28	0.57	0.85	11.3	4.72	0.25	0.56	0.86	10.50	4.98	0.22	0.56	0.88
	1135	12.7	4.51	0.32	0.65	0.95	11.8	4.75	0.30	0.65	0.97	11.00	5.00	0.28	0.65	0.99

17.5 KW - ZHB060S4 - HEATING CAPACITY

Indoor Coil Air Volume 70°F Dry Bulb	Air Temperature Entering Outdoor Coil									
	18°C		7°C		-4°C		-15°C		-26°C	
	Total Heating Capacity	Comp. Motor Input	Total Heating Capacity	Comp. Motor Input	Total Heating Capacity	Comp. Motor Input	Total Heating Capacity	Comp. Motor Input	Total Heating Capacity	Comp. Motor Input
L/s	kW	kW	kW	kW	kW	kW	kW	kW	kW	kW
755	15.5	2.96	13.3	2.85	11.1	2.74	8.0	2.53	3.8	1.87
944	15.7	2.80	13.5	2.69	11.4	2.58	8.2	2.37	4.1	1.71
1133	16.0	2.70	13.7	2.59	11.6	2.48	8.4	2.27	4.3	1.61

COOLING / HEATING RATINGS

NOTE – For Temperatures and Capacities not shown in tables, see bulletin – Cooling Unit Rating Table Correction Factor Data in Miscellaneous Engineering Data section.

21.0 KW - ZHB072S4 - COOLING CAPACITY

Entering Wet Bulb Temperature	Total Air Volume	Outdoor Air Temperature Entering Outdoor Coil																			
		26.7°C					35°C					43.3°C					51.7°C				
		Total Cool Cap.	Comp. Motor Input	Sensible To Total Ratio (S/T)			Total Cool Cap.	Comp. Motor Input	Sensible To Total Ratio (S/T)			Total Cool Cap.	Comp. Motor Input	Sensible To Total Ratio (S/T)			Total Cool Cap.	Comp. Motor Input	Sensible To Total Ratio (S/T)		
				Dry Bulb					Dry Bulb					Dry Bulb					Dry Bulb		
L/s	kW	kW	24°C	27°C	29°C	kW	kW	24°C	27°C	29°C	kW	kW	24°C	27°C	29°C	kW	kW	24°C	27°C	29°C	
17.2°C	850	18.2	3.81	0.74	0.89	1.00	16.4	4.52	0.76	0.92	1.00	14.5	5.39	0.79	0.97	1.00	12.4	6.42	0.84	1.00	1.00
	1085	19.3	3.86	0.81	0.97	1.00	17.4	4.57	0.84	1.00	1.00	15.6	5.46	0.88	1.00	1.00	13.4	6.47	0.94	1.00	1.00
	1320	20.3	3.89	0.87	1.00	1.00	18.5	4.62	0.90	1.00	1.00	16.4	5.49	0.96	1.00	1.00	14.1	6.51	1.00	1.00	1.00
19.4°C	850	19.4	3.85	0.58	0.72	0.86	17.5	4.57	0.58	0.74	0.89	15.4	5.43	0.59	0.77	0.94	13.0	6.45	0.61	0.82	1.00
	1085	20.4	3.89	0.62	0.79	0.94	18.4	4.62	0.63	0.82	0.98	16.2	5.48	0.65	0.86	1.00	13.7	6.48	0.68	0.92	1.00
	1320	21.1	3.92	0.66	0.85	1.00	19.0	4.65	0.68	0.89	1.00	16.7	5.50	0.70	0.94	1.00	14.2	6.53	0.74	1.00	1.00
21.7°C	850	20.5	3.89	0.43	0.57	0.70	18.6	4.63	0.42	0.57	0.72	16.4	5.49	0.41	0.58	0.75	14.0	6.50	0.41	0.60	0.80
	1085	21.6	3.95	0.45	0.61	0.77	19.5	4.67	0.45	0.62	0.80	17.2	5.52	0.44	0.64	0.84	14.6	6.54	0.44	0.68	0.90
	1320	22.3	3.98	0.47	0.65	0.83	20.1	4.70	0.47	0.67	0.87	17.7	5.56	0.47	0.70	0.92	15.0	6.57	0.47	0.74	0.99

Entering Wet Bulb Temperature	Total Air Volume	Outdoor Air Temperature Entering Outdoor Coil														
		46°C					48°C					50°C				
		Total Cool Cap.	Comp. Motor Input	Sensible To Total Ratio (S/T)			Total Cool Cap.	Comp. Motor Input	Sensible To Total Ratio (S/T)			Total Cool Cap.	Comp. Motor Input	Sensible To Total Ratio (S/T)		
				Dry Bulb					Dry Bulb					Dry Bulb		
L/s	kW	kW	24°C	27°C	29°C	kW	kW	24°C	27°C	29°C	kW	kW	24°C	27°C	29°C	
17.2°C	850	13.8	5.70	0.80	0.99	1.00	13.3	5.93	0.81	1.00	1.00	12.8	6.19	0.83	1.00	1.00
	1085	14.9	5.76	0.89	1.00	1.00	14.4	6.00	0.91	1.00	1.00	13.9	6.25	0.93	1.00	1.00
	1320	15.7	5.80	0.98	1.00	1.00	15.2	6.05	0.99	1.00	1.00	14.7	6.29	1.00	1.00	1.00
19.4°C	850	14.7	5.74	0.60	0.78	0.96	14.2	5.99	0.60	0.79	0.97	13.6	6.22	0.60	0.80	0.99
	1085	15.4	5.77	0.66	0.88	1.00	14.8	6.02	0.66	0.89	1.00	14.2	6.26	0.67	0.91	1.00
	1320	16.0	5.81	0.71	0.96	1.00	15.4	6.05	0.72	0.97	1.00	14.7	6.29	0.73	0.99	1.00
21.7°C	850	15.7	5.79	0.41	0.59	0.76	15.1	6.03	0.41	0.59	0.77	14.5	6.29	0.41	0.60	0.78
	1085	16.4	5.84	0.44	0.65	0.85	15.8	6.08	0.44	0.66	0.87	15.1	6.31	0.44	0.67	0.88
	1320	16.9	5.86	0.47	0.71	0.94	16.2	6.09	0.47	0.72	0.96	15.6	6.33	0.47	0.73	0.98

21.0 KW - ZHB072S4 - HEATING CAPACITY

Indoor Coil Air Volume 70°F Dry Bulb	Air Temperature Entering Outdoor Coil									
	18°C		7°C		-4°C		-15°C		-26°C	
	Total Heating Capacity	Comp. Motor Input	Total Heating Capacity	Comp. Motor Input	Total Heating Capacity	Comp. Motor Input	Total Heating Capacity	Comp. Motor Input	Total Heating Capacity	Comp. Motor Input
L/s	kW	kW	kW	kW	kW	kW	kW	kW	kW	kW
850	22.1	4.47	16.9	4.1	11.8	3.72	7.1	3.26	3.6	2.45
1085	22.4	4.26	17.2	3.89	12.1	3.52	7.4	3.05	3.9	2.24
1320	22.6	4.16	17.5	3.78	12.3	3.41	7.6	2.95	4.2	2.13

BLOWER DATA - BELT DRIVE - ZHA036 - DOWNFLOW

BLOWER TABLE INCLUDES RESISTANCE FOR BASE UNIT ONLY WITH DRY INDOOR COIL AND AIR FILTERS IN PLACE.
FOR ALL UNITS ADD:

1 - Any factory installed options air resistance (heat section, economizer, wet coil, etc.).

2 - Any field installed accessories air resistance (duct resistance, diffuser, etc.).

See page 33 for blower motors and drives and wet coil and options/accessory air resistance data.

Air Volume		External Static - Pa (in. w.g.)																							
		25 (0.10)		50 (0.20)		75 (0.30)		100 (0.40)		125 (0.50)		150 (0.60)		175 (0.70)		200 (0.80)									
L/s	cfm	Rev/ min	kW	BHP	Rev/ min	kW	BHP	Rev/ min	kW	BHP	Rev/ min	kW	BHP	Rev/ min	kW	BHP	Rev/ min	kW	BHP						
425	900	562	0.12	0.16	629	0.13	0.18	699	0.14	0.19	771	0.15	0.20	840	0.16	0.22	904	0.18	0.24	962	0.19	0.26	1015	0.22	0.29
472	1000	586	0.13	0.18	654	0.15	0.20	725	0.16	0.21	796	0.17	0.23	864	0.19	0.25	927	0.20	0.27	983	0.22	0.30	1034	0.25	0.33
519	1100	612	0.15	0.20	681	0.16	0.22	752	0.18	0.24	823	0.19	0.26	890	0.21	0.28	950	0.23	0.31	1004	0.25	0.34	1054	0.28	0.37
566	1200	641	0.17	0.23	711	0.19	0.25	783	0.20	0.27	852	0.22	0.29	917	0.24	0.32	975	0.26	0.35	1027	0.29	0.39	1074	0.31	0.42
613	1300	673	0.19	0.25	744	0.21	0.28	815	0.22	0.30	882	0.25	0.33	944	0.27	0.36	1000	0.30	0.40	1050	0.33	0.44	1096	0.36	0.48
661	1400	709	0.22	0.29	779	0.24	0.32	849	0.25	0.34	914	0.28	0.37	973	0.31	0.41	1026	0.34	0.45	1074	0.37	0.49	1118	0.40	0.53
708	1500	747	0.25	0.33	816	0.27	0.36	883	0.29	0.39	945	0.31	0.42	1001	0.34	0.46	1052	0.38	0.51	1098	0.41	0.55	1141	0.44	0.59

External Static - Pa (in. w.g.)

Air Volume		External Static - Pa (in. w.g.)																							
		225 (0.90)		250 (1.00)		275 (1.10)		300 (1.20)		325 (1.30)		350 (1.40)		375 (1.50)		400 (1.60)									
L/s	cfm	Rev/ min	kW	BHP	Rev/ min	kW	BHP	Rev/ min	kW	BHP	Rev/ min	kW	BHP	Rev/ min	kW	BHP	Rev/ min	kW	BHP						
425	900	1065	0.24	0.32	1112	0.26	0.35	1158	0.28	0.38	1202	0.31	0.41	1243	0.33	0.44	1284	0.36	0.48	1323	0.39	0.52	1364	0.41	0.55
472	1000	1082	0.27	0.36	1128	0.29	0.39	1173	0.31	0.42	1216	0.34	0.45	1257	0.37	0.49	1297	0.40	0.53	1336	0.43	0.57	1375	0.45	0.60
519	1100	1100	0.30	0.40	1145	0.33	0.44	1189	0.35	0.47	1231	0.38	0.51	1272	0.40	0.54	1311	0.43	0.58	1349	0.46	0.62	1388	0.49	0.66
566	1200	1119	0.34	0.45	1163	0.37	0.49	1206	0.39	0.52	1247	0.42	0.56	1287	0.45	0.60	1326	0.48	0.64	1364	0.51	0.68	1402	0.54	0.72
613	1300	1139	0.38	0.51	1182	0.41	0.55	1224	0.43	0.58	1265	0.46	0.62	1304	0.49	0.66	1342	0.53	0.71	1379	0.56	0.75	1416	0.59	0.79
661	1400	1160	0.43	0.57	1202	0.46	0.61	1243	0.48	0.65	1283	0.51	0.69	1322	0.54	0.73	1359	0.58	0.78	1396	0.61	0.82	1432	0.65	0.87
708	1500	1182	0.48	0.64	1223	0.51	0.68	1263	0.54	0.72	1303	0.57	0.76	1341	0.60	0.81	1378	0.63	0.85	1414	0.67	0.90	1449	0.70	0.94

BLOWER DATA - BELT DRIVE - ZHA036 - HORIZONTAL

BLOWER TABLE INCLUDES RESISTANCE FOR BASE UNIT ONLY WITH DRY INDOOR COIL AND AIR FILTERS IN PLACE.
FOR ALL UNITS ADD:

1 - Any factory installed options air resistance (heat section, economizer, wet coil, etc.).

2 - Any field installed accessories air resistance (duct resistance, diffuser, etc.).

See page 33 for blower motors and drives and wet coil and options/accessory air resistance data.

Air Volume		External Static - Pa (in. w.g.)																							
		25 (0.10)		50 (0.20)		75 (0.30)		100 (0.40)		125 (0.50)		150 (0.60)		175 (0.70)		200 (0.80)									
L/s	cfm	Rev/ min	kW	BHP	Rev/ min	kW	BHP	Rev/ min	kW	BHP	Rev/ min	kW	BHP	Rev/ min	kW	BHP	Rev/ min	kW	BHP						
425	900	580	0.10	0.14	649	0.13	0.17	721	0.14	0.19	794	0.16	0.22	868	0.18	0.24	938	0.20	0.27	998	0.22	0.30	1045	0.25	0.33
472	1000	612	0.13	0.17	681	0.14	0.19	752	0.16	0.22	825	0.19	0.25	897	0.20	0.27	963	0.22	0.30	1017	0.25	0.33	1061	0.28	0.37
519	1100	647	0.15	0.20	717	0.17	0.23	788	0.19	0.26	858	0.21	0.28	926	0.23	0.31	986	0.25	0.34	1036	0.28	0.38	1077	0.31	0.41
566	1200	687	0.17	0.23	757	0.19	0.26	826	0.22	0.29	893	0.24	0.32	955	0.26	0.35	1008	0.29	0.39	1054	0.31	0.42	1095	0.34	0.46
613	1300	730	0.20	0.27	798	0.22	0.30	864	0.25	0.33	926	0.28	0.37	982	0.30	0.40	1030	0.33	0.44	1073	0.35	0.47	1116	0.38	0.51
661	1400	775	0.23	0.31	840	0.25	0.34	902	0.28	0.38	959	0.31	0.42	1009	0.34	0.46	1054	0.37	0.50	1096	0.40	0.53	1140	0.42	0.56
708	1500	820	0.27	0.36	881	0.30	0.40	939	0.33	0.44	993	0.37	0.49	1039	0.40	0.53	1082	0.42	0.56	1124	0.44	0.59	1168	0.46	0.62

Air Volume		External Static - Pa (in. w.g.)																							
		225 (0.90)		250 (1.00)		275 (1.10)		300 (1.20)		325 (1.30)		350 (1.40)		375 (1.50)		400 (1.60)									
L/s	cfm	Rev/ min	kW	BHP	Rev/ min	kW	BHP	Rev/ min	kW	BHP	Rev/ min	kW	BHP	Rev/ min	kW	BHP	Rev/ min	kW	BHP						
425	900	1091	0.27	0.36	1140	0.28	0.38	1188	0.30	0.40	1232	0.32	0.43	1272	0.34	0.46	1309	0.37	0.49	1346	0.40	0.53	1383	0.43	0.57
472	1000	1105	0.30	0.40	1154	0.31	0.42	1201	0.34	0.45	1245	0.35	0.47	1284	0.37	0.50	1321	0.40	0.54	1357	0.43	0.58	1394	0.46	0.62
519	1100	1121	0.33	0.44	1169	0.35	0.47	1216	0.37	0.49	1259	0.39	0.52	1298	0.42	0.56	1335	0.45	0.60	1370	0.48	0.64	1406	0.51	0.69
566	1200	1139	0.37	0.49	1187	0.39	0.52	1234	0.40	0.54	1276	0.43	0.58	1314	0.46	0.62	1350	0.49	0.66	1385	0.53	0.71	1421	0.56	0.75
613	1300	1161	0.40	0.54	1208	0.43	0.57	1254	0.45	0.60	1295	0.48	0.64	1332	0.51	0.69	1366	0.54	0.73	1401	0.58	0.78	1436	0.62	0.83
661	1400	1185	0.44	0.59	1232	0.47	0.63	1276	0.50	0.67	1315	0.53	0.71	1351	0.57	0.76	1384	0.60	0.81	1419	0.64	0.86	1454	0.67	0.90
708	1500	1212	0.49	0.66	1257	0.52	0.70	1299	0.55	0.74	1337	0.59	0.79	1371	0.63	0.84	1404	0.66	0.89	1438	0.70	0.94	1473	0.74	0.99

BLOWER DATA - BELT DRIVE - ZHA048 - DOWNFLOW

BLOWER TABLE INCLUDES RESISTANCE FOR BASE UNIT ONLY WITH DRY INDOOR COIL AND AIR FILTERS IN PLACE.
FOR ALL UNITS ADD:

1 - Any factory installed options air resistance (heat section, economizer, wet coil, etc.).

2 - Any field installed accessories air resistance (duct resistance, diffuser, etc.).

See page 33 for blower motors and drives and wet coil and options/accessory air resistance data.

Air Volume		External Static - Pa (in. w.g.)																							
		25 (0.10)		50 (0.20)		75 (0.30)		100 (0.40)		125 (0.50)		150 (0.60)		175 (0.70)		200 (0.80)									
L/s	cfm	Rev/ min	kW	BHP	Rev/ min	kW	BHP	Rev/ min	kW	BHP	Rev/ min	kW	BHP	Rev/ min	kW	BHP	Rev/ min	kW	BHP						
566	1200	641	0.17	0.23	711	0.19	0.25	783	0.20	0.27	852	0.22	0.29	917	0.24	0.32	975	0.26	0.35	1027	0.29	0.39	1074	0.31	0.42
613	1300	673	0.19	0.25	744	0.21	0.28	815	0.22	0.30	882	0.25	0.33	944	0.27	0.36	1000	0.30	0.40	1050	0.33	0.44	1096	0.36	0.48
661	1400	709	0.22	0.29	779	0.24	0.32	849	0.25	0.34	914	0.28	0.37	973	0.31	0.41	1026	0.34	0.45	1074	0.37	0.49	1118	0.40	0.53
708	1500	747	0.25	0.33	816	0.27	0.36	883	0.29	0.39	945	0.31	0.42	1001	0.34	0.46	1052	0.38	0.51	1098	0.41	0.55	1141	0.44	0.59
755	1600	787	0.28	0.38	854	0.31	0.41	918	0.33	0.44	976	0.36	0.48	1030	0.39	0.52	1078	0.42	0.56	1123	0.46	0.61	1164	0.49	0.66
802	1700	827	0.32	0.43	892	0.34	0.46	952	0.37	0.49	1007	0.40	0.53	1058	0.43	0.58	1105	0.47	0.63	1148	0.51	0.68	1189	0.54	0.73
849	1800	868	0.36	0.48	929	0.39	0.52	986	0.41	0.55	1038	0.44	0.59	1087	0.48	0.64	1132	0.51	0.69	1174	0.56	0.75	1214	0.60	0.8
897	1900	907	0.40	0.54	966	0.43	0.58	1019	0.46	0.62	1069	0.49	0.66	1116	0.53	0.71	1160	0.57	0.77	1200	0.61	0.82	1240	0.66	0.88
944	2000	946	0.45	0.60	1001	0.48	0.65	1053	0.51	0.69	1101	0.55	0.74	1146	0.59	0.79	1188	0.63	0.85	1228	0.68	0.91	1267	0.73	0.98

Air Volume		External Static - Pa (in. w.g.)																							
		225 (0.90)		250 (1.00)		275 (1.10)		300 (1.20)		325 (1.30)		350 (1.40)		375 (1.50)		400 (1.60)									
L/s	cfm	Rev/ min	kW	BHP	Rev/ min	kW	BHP	Rev/ min	kW	BHP	Rev/ min	kW	BHP	Rev/ min	kW	BHP	Rev/ min	kW	BHP						
566	1200	1119	0.34	0.45	1163	0.37	0.49	1206	0.39	0.52	1247	0.42	0.56	1287	0.45	0.60	1326	0.48	0.64	1364	0.51	0.68	1402	0.54	0.72
613	1300	1139	0.38	0.51	1182	0.41	0.55	1224	0.43	0.58	1265	0.46	0.62	1304	0.49	0.66	1342	0.53	0.71	1379	0.56	0.75	1416	0.59	0.79
661	1400	1160	0.43	0.57	1202	0.46	0.61	1243	0.48	0.65	1283	0.51	0.69	1322	0.54	0.73	1359	0.58	0.78	1396	0.61	0.82	1432	0.65	0.87
708	1500	1182	0.48	0.64	1223	0.51	0.68	1263	0.54	0.72	1303	0.57	0.76	1341	0.60	0.81	1378	0.63	0.85	1414	0.67	0.90	1449	0.70	0.94
755	1600	1205	0.52	0.70	1245	0.56	0.75	1284	0.59	0.79	1323	0.63	0.84	1361	0.66	0.88	1397	0.69	0.93	1432	0.73	0.98	1467	0.77	1.03
802	1700	1228	0.58	0.78	1268	0.61	0.82	1307	0.65	0.87	1345	0.69	0.92	1382	0.72	0.97	1417	0.76	1.02	1452	0.80	1.07	1486	0.83	1.11
849	1800	1253	0.63	0.85	1292	0.68	0.91	1331	0.72	0.96	1368	0.75	1.01	1404	0.79	1.06	1439	0.83	1.11	1473	0.87	1.16	1506	0.90	1.21
897	1900	1279	0.70	0.94	1317	0.75	1.00	1355	0.78	1.05	1392	0.82	1.10	1427	0.87	1.16	1461	0.90	1.21	1494	0.94	1.26	1527	0.98	1.31
944	2000	1305	0.78	1.04	1343	0.82	1.10	1380	0.86	1.15	1416	0.90	1.21	1450	0.94	1.26	1484	0.98	1.32	1516	1.02	1.37	1549	1.06	1.42

BLOWER DATA - BELT DRIVE - ZHA048 - HORIZONTAL

BLOWER TABLE INCLUDES RESISTANCE FOR BASE UNIT ONLY WITH DRY INDOOR COIL AND AIR FILTERS IN PLACE.

FOR ALL UNITS ADD:

1 - Any factory installed options air resistance (heat section, economizer, wet coil, etc.).

2 - Any field installed accessories air resistance (duct resistance, diffuser, etc.).

See page 33 for blower motors and drives and wet coil and options/accessory air resistance data.

Air Volume		External Static - Pa (in. w.g.)																							
		25 (0.10)		50 (0.20)		75 (0.30)		100 (0.40)		125 (0.50)		150 (0.60)		175 (0.70)		200 (0.80)									
L/s	cfm	Rev/ min	kW	BHP	Rev/ min	kW	BHP	Rev/ min	kW	BHP	Rev/ min	kW	BHP	Rev/ min	kW	BHP	Rev/ min	kW	BHP						
566	1200	687	0.17	0.23	757	0.19	0.26	826	0.22	0.29	893	0.24	0.32	955	0.26	0.35	1008	0.29	0.39	1054	0.31	0.42	1095	0.34	0.46
613	1300	730	0.20	0.27	798	0.22	0.30	864	0.25	0.33	926	0.28	0.37	982	0.30	0.40	1030	0.33	0.44	1073	0.35	0.47	1116	0.38	0.51
661	1400	775	0.23	0.31	840	0.25	0.34	902	0.28	0.38	959	0.31	0.42	1009	0.34	0.46	1054	0.37	0.50	1096	0.40	0.53	1140	0.42	0.56
708	1500	820	0.27	0.36	881	0.30	0.40	939	0.33	0.44	993	0.37	0.49	1039	0.40	0.53	1082	0.42	0.56	1124	0.44	0.59	1168	0.46	0.62
755	1600	864	0.31	0.42	921	0.34	0.46	976	0.38	0.51	1027	0.42	0.56	1072	0.45	0.60	1113	0.47	0.63	1155	0.49	0.66	1198	0.51	0.69
802	1700	907	0.36	0.48	961	0.40	0.53	1013	0.43	0.58	1061	0.47	0.63	1105	0.50	0.67	1146	0.52	0.70	1187	0.54	0.73	1230	0.57	0.77
849	1800	948	0.42	0.56	999	0.46	0.61	1049	0.49	0.66	1096	0.53	0.71	1139	0.56	0.75	1180	0.58	0.78	1221	0.61	0.82	1262	0.64	0.86
897	1900	987	0.48	0.64	1037	0.51	0.69	1086	0.55	0.74	1132	0.59	0.79	1174	0.62	0.83	1214	0.64	0.86	1255	0.67	0.90	1295	0.71	0.95
944	2000	1028	0.54	0.73	1076	0.58	0.78	1123	0.62	0.83	1168	0.65	0.87	1210	0.68	0.91	1250	0.72	0.96	1289	0.75	1.00	1328	0.79	1.06

Air Volume		External Static - Pa (in. w.g.)																							
		225 (0.90)		250 (1.00)		275 (1.10)		300 (1.20)		325 (1.30)		350 (1.40)		375 (1.50)		400 (1.60)									
L/s	cfm	Rev/ min	kW	BHP	Rev/ min	kW	BHP	Rev/ min	kW	BHP	Rev/ min	kW	BHP	Rev/ min	kW	BHP	Rev/ min	kW	BHP						
566	1200	1139	0.37	0.49	1187	0.39	0.52	1234	0.40	0.54	1276	0.43	0.58	1314	0.46	0.62	1350	0.49	0.66	1385	0.53	0.71	1421	0.56	0.75
613	1300	1161	0.40	0.54	1208	0.43	0.57	1254	0.45	0.60	1295	0.48	0.64	1332	0.51	0.69	1366	0.54	0.73	1401	0.58	0.78	1436	0.62	0.83
661	1400	1185	0.44	0.59	1232	0.47	0.63	1276	0.50	0.67	1315	0.53	0.71	1351	0.57	0.76	1384	0.60	0.81	1419	0.64	0.86	1454	0.67	0.90
708	1500	1212	0.49	0.66	1257	0.52	0.70	1299	0.55	0.74	1337	0.59	0.79	1371	0.63	0.84	1404	0.66	0.89	1438	0.70	0.94	1473	0.74	0.99
755	1600	1242	0.54	0.73	1284	0.57	0.77	1324	0.61	0.82	1360	0.66	0.88	1394	0.69	0.93	1426	0.74	0.99	1460	0.78	1.04	1495	0.81	1.08
802	1700	1272	0.60	0.81	1312	0.64	0.86	1350	0.69	0.92	1385	0.73	0.98	1418	0.78	1.04	1451	0.81	1.09	1485	0.85	1.14	1519	0.89	1.19
849	1800	1302	0.67	0.90	1341	0.72	0.96	1377	0.76	1.02	1411	0.81	1.08	1444	0.86	1.15	1477	0.90	1.20	1510	0.93	1.25	1544	0.97	1.30
897	1900	1334	0.75	1.01	1371	0.80	1.07	1406	0.84	1.13	1439	0.90	1.20	1471	0.94	1.26	1504	0.98	1.32	1537	1.02	1.37	1571	1.05	1.41
944	2000	1365	0.84	1.12	1401	0.89	1.19	1435	0.93	1.25	1468	0.98	1.32	1500	1.03	1.38	1532	1.07	1.44	1565	1.11	1.49	1598	1.14	1.53

BLOWER DATA - BELT DRIVE - ZHA060 - DOWNFLOW

BLOWER TABLE INCLUDES RESISTANCE FOR BASE UNIT ONLY WITH DRY INDOOR COIL AND AIR FILTERS IN PLACE.

FOR ALL UNITS ADD:

- 1 - Any factory installed options air resistance (heat section, economizer, wet coil, etc.).
- 2 - Any field installed accessories air resistance (duct resistance, diffuser, etc.).

See page 33 for blower motors and drives and wet coil and options/accessory air resistance data.

Air Volume		External Static - Pa (in. w.g.)																							
		25 (0.10)		50 (0.20)		75 (0.30)		100 (0.40)		125 (0.50)		150 (0.60)		175 (0.70)		200 (0.80)									
L/s	cfm	Rev/min	BHP	Rev/min	BHP	Rev/min	BHP	Rev/min	BHP	Rev/min	BHP	Rev/min	BHP	Rev/min	BHP	Rev/min	BHP								
755	1600	764	0.26	0.35	822	0.29	0.39	880	0.31	0.42	936	0.34	0.46	991	0.38	0.51	1042	0.41	0.45	1091	0.45	0.60	1136	0.48	0.64
802	1700	801	0.30	0.40	857	0.33	0.44	913	0.36	0.48	968	0.39	0.52	1020	0.43	0.57	1070	0.46	0.61	1117	0.49	0.66	1162	0.53	0.71
849	1800	838	0.34	0.46	893	0.37	0.50	947	0.40	0.54	1000	0.43	0.58	1051	0.47	0.63	1099	0.51	0.68	1145	0.54	0.73	1188	0.58	0.78
897	1900	876	0.39	0.52	929	0.42	0.56	982	0.46	0.61	1033	0.48	0.65	1082	0.52	0.70	1129	0.56	0.75	1173	0.60	0.80	1215	0.63	0.85
944	2000	914	0.44	0.59	966	0.47	0.63	1017	0.51	0.68	1067	0.54	0.72	1115	0.57	0.77	1160	0.62	0.83	1203	0.66	0.88	1244	0.70	0.94
991	2100	953	0.49	0.66	1004	0.53	0.71	1054	0.57	0.76	1102	0.60	0.81	1148	0.64	0.86	1192	0.69	0.92	1233	0.73	0.98	1273	0.78	1.04
1038	2200	993	0.55	0.74	1042	0.59	0.79	1090	0.63	0.85	1137	0.67	0.90	1181	0.72	0.96	1224	0.76	1.02	1264	0.81	1.09	1303	0.86	1.15
1085	2300	1033	0.62	0.83	1081	0.66	0.89	1128	0.70	0.94	1173	0.75	1.01	1216	0.80	1.07	1257	0.85	1.14	1296	0.90	1.20	1334	0.95	1.27
1133	2400	1074	0.69	0.93	1120	0.74	0.99	1166	0.78	1.05	1209	0.84	1.12	1251	0.89	1.19	1291	0.94	1.26	1329	0.99	1.33	1366	1.05	1.41

Air Volume		325 (1.30)												350 (1.40)												375 (1.50)												400 (1.60)											
		225 (0.90)		250 (1.00)		275 (1.10)		300 (1.20)		325 (1.30)		350 (1.40)		375 (1.50)		400 (1.60)		225 (0.90)		250 (1.00)		275 (1.10)		300 (1.20)		325 (1.30)		350 (1.40)		375 (1.50)		400 (1.60)																	
L/s	cfm	Rev/min	BHP	Rev/min	BHP	Rev/min	BHP	Rev/min	BHP	Rev/min	BHP	Rev/min	BHP	Rev/min	BHP	Rev/min	BHP	Rev/min	BHP	Rev/min	BHP	Rev/min	BHP	Rev/min	BHP	Rev/min	BHP	Rev/min	BHP	Rev/min	BHP																		
755	1600	1180	0.51	0.68	1222	0.54	0.72	1263	0.57	0.76	1303	0.60	0.80	1341	0.63	0.85	1378	0.67	0.90	1414	0.70	0.94	1449	0.74	0.99	1488	0.87	1.17	1531	1.03	1.38																		
802	1700	1204	0.56	0.75	1245	0.59	0.79	1285	0.63	0.84	1325	0.66	0.88	1362	0.69	0.93	1398	0.73	0.98	1434	0.77	1.03	1468	0.81	1.08	1498	0.99	1.33	1554	1.12	1.50																		
849	1800	1229	0.62	0.83	1270	0.65	0.87	1309	0.69	0.92	1347	0.72	0.97	1384	0.76	1.02	1420	0.80	1.07	1454	0.84	1.12	1488	0.87	1.17	1509	1.23	1.57	1578	1.21	1.62																		
897	1900	1256	0.68	0.91	1296	0.72	0.96	1334	0.75	1.01	1371	0.80	1.07	1407	0.84	1.12	1442	0.87	1.17	1476	0.92	1.23	1509	0.95	1.28	1531	1.33	1.67	1602	1.31	1.75																		
944	2000	1284	0.75	1.00	1322	0.79	1.06	1360	0.83	1.11	1396	0.87	1.17	1431	0.92	1.23	1465	0.95	1.28	1498	0.99	1.33	1531	1.03	1.38	1554	1.45	1.81	1628	1.41	1.89																		
991	2100	1312	0.82	1.10	1350	0.87	1.16	1386	0.91	1.22	1422	0.95	1.28	1456	1.00	1.34	1489	1.04	1.40	1521	1.08	1.45	1554	1.12	1.50	1578	1.57	2.01	1652	1.51	2.01																		
1038	2200	1341	0.91	1.22	1378	0.95	1.28	1414	1.00	1.34	1448	1.05	1.41	1481	1.09	1.46	1513	1.13	1.52	1546	1.17	1.57	1578	1.21	1.62	1602	1.70	2.21	1682	1.61	2.16																		
1085	2300	1371	1.00	1.34	1407	1.05	1.41	1442	1.10	1.47	1475	1.15	1.54	1507	1.19	1.59	1539	1.23	1.65	1571	1.27	1.70	1602	1.31	1.75	1628	1.84	2.41	1712	1.71	2.28																		
1133	2400	1402	1.10	1.48	1436	1.16	1.55	1470	1.20	1.61	1503	1.25	1.67	1535	1.29	1.73	1566	1.34	1.79	1597	1.37	1.84	1628	1.41	1.89	1652	2.01	2.61	1741	1.89	2.48																		

BLOWER DATA - BELT DRIVE - ZHA060 - HORIZONTAL

BLOWER TABLE INCLUDES RESISTANCE FOR BASE UNIT ONLY WITH DRY INDOOR COIL AND AIR FILTERS IN PLACE.
FOR ALL UNITS ADD:

1 - Any factory installed options air resistance (heat section, economizer, wet coil, etc.).

2 - Any field installed accessories air resistance (duct resistance, diffuser, etc.).

See page 33 for blower motors and drives and wet coil and options/accessory air resistance data.

Air Volume		External Static - Pa (in. w.g.)																							
		25 (0.10)		50 (0.20)		75 (0.30)		100 (0.40)		125 (0.50)		150 (0.60)		175 (0.70)		200 (0.80)									
L/s	cfm	Rev/min	kW	BHP	Rev/min	kW	BHP	Rev/min	kW	BHP	Rev/min	kW	BHP	Rev/min	kW	BHP	Rev/min	kW	BHP						
755	1600	783	0.28	0.38	844	0.31	0.41	902	0.33	0.44	957	0.36	0.48	1008	0.39	0.52	1056	0.42	0.56	1100	0.45	0.6	1142	0.48	0.64
802	1700	825	0.33	0.44	882	0.35	0.47	938	0.37	0.5	989	0.40	0.54	1038	0.43	0.57	1083	0.46	0.62	1126	0.49	0.66	1166	0.53	0.71
849	1800	866	0.37	0.50	921	0.40	0.53	973	0.42	0.56	1021	0.45	0.6	1067	0.48	0.64	1111	0.51	0.68	1152	0.54	0.73	1191	0.58	0.78
897	1900	907	0.42	0.56	959	0.44	0.59	1008	0.47	0.63	1054	0.49	0.66	1098	0.53	0.71	1139	0.56	0.75	1179	0.60	0.8	1217	0.64	0.86
944	2000	948	0.47	0.63	996	0.49	0.66	1042	0.52	0.7	1086	0.55	0.74	1128	0.58	0.78	1168	0.62	0.83	1207	0.66	0.89	1244	0.70	0.94
991	2100	987	0.52	0.70	1033	0.55	0.74	1077	0.58	0.78	1119	0.61	0.82	1159	0.65	0.87	1198	0.69	0.93	1235	0.74	0.99	1272	0.78	1.05
1038	2200	1026	0.58	0.78	1070	0.61	0.82	1112	0.65	0.87	1152	0.69	0.92	1191	0.73	0.98	1228	0.77	1.03	1265	0.82	1.1	1301	0.87	1.16
1085	2300	1064	0.66	0.88	1106	0.69	0.92	1147	0.72	0.97	1186	0.77	1.03	1223	0.81	1.09	1260	0.86	1.15	1295	0.91	1.22	1331	0.95	1.28
1133	2400	1102	0.73	0.98	1143	0.77	1.03	1182	0.81	1.08	1220	0.86	1.15	1256	0.90	1.21	1292	0.95	1.28	1327	1.01	1.35	1362	1.06	1.42

Air Volume		325 (1.30)												350 (1.40)			375 (1.50)			400 (1.60)					
		Rev/min	kW	BHP	Rev/min	kW	BHP	Rev/min	kW	BHP	Rev/min	kW	BHP	Rev/min	kW	BHP	Rev/min	kW	BHP						
755	1600	1183	0.51	0.68	1223	0.54	0.72	1263	0.57	0.76	1302	0.60	0.81	1340	0.64	0.86	1377	0.68	0.91	1413	0.71	0.95	1448	0.75	1
802	1700	1205	0.56	0.75	1245	0.59	0.79	1284	0.63	0.84	1322	0.66	0.89	1360	0.70	0.94	1396	0.74	0.99	1431	0.78	1.04	1465	0.81	1.09
849	1800	1230	0.62	0.83	1268	0.65	0.87	1306	0.69	0.92	1344	0.73	0.98	1380	0.77	1.03	1416	0.81	1.08	1450	0.84	1.13	1483	0.89	1.19
897	1900	1255	0.68	0.91	1292	0.72	0.96	1330	0.76	1.02	1367	0.80	1.07	1402	0.84	1.13	1437	0.88	1.18	1470	0.93	1.24	1503	0.96	1.29
944	2000	1281	0.75	1	1318	0.79	1.06	1355	0.84	1.12	1391	0.88	1.18	1425	0.92	1.23	1459	0.96	1.29	1492	1.01	1.35	1524	1.04	1.4
991	2100	1308	0.83	1.11	1345	0.87	1.17	1381	0.92	1.23	1416	0.96	1.29	1450	1.01	1.35	1482	1.05	1.41	1514	1.09	1.46	1546	1.13	1.52
1038	2200	1337	0.92	1.23	1372	0.96	1.29	1408	1.01	1.35	1442	1.06	1.42	1475	1.10	1.47	1507	1.14	1.53	1538	1.19	1.59	1569	1.22	1.64
1085	2300	1366	1.01	1.35	1401	1.06	1.42	1435	1.11	1.49	1469	1.16	1.55	1501	1.20	1.61	1532	1.25	1.67	1563	1.28	1.72	1594	1.32	1.77
1133	2400	1396	1.11	1.49	1431	1.16	1.56	1464	1.22	1.63	1496	1.26	1.69	1528	1.31	1.75	1559	1.35	1.81	1589	1.39	1.86	1619	1.42	1.91

BLOWER DATA - BELT DRIVE - ZHB036 - DOWNFLOW

BLOWER TABLE INCLUDES RESISTANCE FOR BASE UNIT ONLY WITH DRY INDOOR COIL AND AIR FILTERS IN PLACE.
FOR ALL UNITS ADD:

1 - Any factory installed options air resistance (heat section, economizer, wet coil, etc.).

2 - Any field installed accessories air resistance (duct resistance, diffuser, etc.).

See page 33 for blower motors and drives and wet coil and options/accessory air resistance data.

Air Volume		External Static - Pa (in. w.g.)																										
		25 (0.10)		50 (0.20)		75 (0.30)		100 (0.40)		125 (0.50)		150 (0.60)		175 (0.70)		200 (0.80)												
L/s	cfm	Rev/ min	kW	BHP	Rev/ min	kW	BHP	Rev/ min	kW	BHP	Rev/ min	kW	BHP	Rev/ min	kW	BHP	Rev/ min	kW	BHP									
425	900	562	0.08	0.11	621	0.10	0.13	0.16	0.13	0.16	685	0.12	0.16	752	0.13	0.18	818	0.16	0.21	883	0.18	0.24	944	0.20	0.27	1001	0.22	0.30
472	1000	584	0.10	0.13	644	0.12	0.16	0.18	0.16	0.21	707	0.13	0.18	773	0.16	0.21	838	0.18	0.24	901	0.20	0.27	960	0.22	0.30	1015	0.25	0.33
519	1100	609	0.12	0.16	669	0.13	0.18	0.21	0.18	0.24	732	0.16	0.21	796	0.18	0.24	860	0.20	0.27	921	0.22	0.30	978	0.25	0.34	1031	0.28	0.37
566	1200	635	0.14	0.19	696	0.16	0.21	0.24	0.20	0.27	758	0.18	0.24	821	0.20	0.27	883	0.23	0.31	942	0.25	0.34	997	0.28	0.38	1049	0.31	0.42
613	1300	664	0.16	0.22	725	0.19	0.25	0.28	0.23	0.31	786	0.21	0.28	848	0.23	0.31	908	0.26	0.35	965	0.29	0.39	1018	0.32	0.43	1068	0.35	0.47
661	1400	696	0.19	0.26	756	0.22	0.29	0.32	0.27	0.36	816	0.24	0.32	876	0.27	0.36	935	0.30	0.40	989	0.33	0.44	1041	0.36	0.48	1089	0.39	0.52
708	1500	729	0.22	0.30	788	0.25	0.33	0.37	0.31	0.41	848	0.28	0.37	906	0.31	0.41	962	0.34	0.45	1015	0.37	0.50	1065	0.40	0.54	1112	0.43	0.58

External Static - Pa (in. w.g.)

Air Volume		External Static - Pa (in. w.g.)																							
		225 (0.90)		250 (1.00)		275 (1.10)		300 (1.20)		325 (1.30)		350 (1.40)		375 (1.50)		400 (1.60)									
L/s	cfm	Rev/ min	kW	BHP	Rev/ min	kW	BHP	Rev/ min	kW	BHP	Rev/ min	kW	BHP	Rev/ min	kW	BHP	Rev/ min	kW	BHP						
425	900	1053	0.24	0.32	1103	0.26	0.35	1149	0.28	0.38	1193	0.31	0.41	1234	0.32	0.43	1274	0.35	0.47	1312	0.37	0.50	1351	0.40	0.53
472	1000	1066	0.27	0.36	1114	0.29	0.39	1160	0.31	0.42	1204	0.34	0.45	1245	0.36	0.48	1284	0.38	0.51	1322	0.40	0.54	1361	0.43	0.58
519	1100	1081	0.30	0.40	1128	0.32	0.43	1173	0.34	0.46	1216	0.37	0.49	1257	0.40	0.53	1296	0.42	0.56	1334	0.45	0.60	1372	0.47	0.63
566	1200	1097	0.34	0.45	1144	0.36	0.48	1188	0.38	0.51	1231	0.40	0.54	1271	0.43	0.58	1310	0.46	0.62	1347	0.49	0.66	1385	0.51	0.69
613	1300	1115	0.37	0.50	1161	0.40	0.53	1204	0.42	0.56	1246	0.45	0.60	1286	0.48	0.64	1325	0.51	0.68	1362	0.54	0.72	1399	0.57	0.76
661	1400	1135	0.42	0.56	1179	0.44	0.59	1222	0.46	0.62	1264	0.49	0.66	1303	0.52	0.70	1341	0.56	0.75	1378	0.59	0.79	1415	0.62	0.83
708	1500	1157	0.46	0.62	1200	0.48	0.65	1242	0.51	0.69	1282	0.54	0.73	1321	0.57	0.77	1359	0.61	0.82	1396	0.64	0.86	1431	0.68	0.91

BLOWER DATA - BELT DRIVE - ZHB036 - HORIZONTAL

BLOWER TABLE INCLUDES RESISTANCE FOR BASE UNIT ONLY WITH DRY INDOOR COIL AND AIR FILTERS IN PLACE.
FOR ALL UNITS ADD:

1 - Any factory installed options air resistance (heat section, economizer, wet coil, etc.).

2 - Any field installed accessories air resistance (duct resistance, diffuser, etc.).

See page 33 for blower motors and drives and wet coil and options/accessory air resistance data.

Air Volume		External Static - Pa (in. w.g.)																							
		25 (0.10)		50 (0.20)		75 (0.30)		100 (0.40)		125 (0.50)		150 (0.60)		175 (0.70)		200 (0.80)									
L/s	cfm	Rev/ min	kW	BHP	Rev/ min	kW	BHP	Rev/ min	kW	BHP	Rev/ min	kW	BHP	Rev/ min	kW	BHP	Rev/ min	kW	BHP						
425	900	560	0.12	0.16	624	0.13	0.18	692	0.15	0.20	761	0.16	0.21	830	0.17	0.23	896	0.19	0.25	956	0.20	0.27	1012	0.22	0.29
472	1000	583	0.13	0.18	647	0.15	0.20	715	0.16	0.22	783	0.18	0.24	850	0.19	0.25	914	0.20	0.27	972	0.22	0.30	1025	0.25	0.33
519	1100	609	0.15	0.20	673	0.16	0.22	740	0.18	0.24	808	0.19	0.26	873	0.21	0.28	934	0.23	0.31	990	0.25	0.34	1041	0.28	0.37
566	1200	637	0.17	0.23	702	0.19	0.25	769	0.20	0.27	835	0.22	0.29	898	0.24	0.32	956	0.26	0.35	1009	0.28	0.38	1058	0.31	0.41
613	1300	669	0.19	0.26	734	0.21	0.28	800	0.22	0.30	863	0.25	0.33	924	0.27	0.36	979	0.29	0.39	1030	0.32	0.43	1077	0.34	0.46
661	1400	704	0.22	0.29	768	0.24	0.32	832	0.26	0.35	894	0.28	0.37	951	0.31	0.41	1004	0.33	0.44	1052	0.36	0.48	1097	0.39	0.52
708	1500	742	0.25	0.33	805	0.27	0.36	867	0.29	0.39	925	0.31	0.42	980	0.34	0.46	1030	0.37	0.50	1076	0.40	0.54	1119	0.43	0.58

Air Volume		External Static - Pa (in. w.g.)																							
		225 (0.90)		250 (1.00)		275 (1.10)		300 (1.20)		325 (1.30)		350 (1.40)		375 (1.50)		400 (1.60)									
L/s	cfm	Rev/ min	kW	BHP	Rev/ min	kW	BHP	Rev/ min	kW	BHP	Rev/ min	kW	BHP	Rev/ min	kW	BHP	Rev/ min	kW	BHP						
425	900	1064	0.24	0.32	1114	0.26	0.35	1162	0.28	0.38	1208	0.31	0.41	1251	0.34	0.45	1293	0.37	0.49	1333	0.39	0.52	1373	0.42	0.56
472	1000	1076	0.27	0.36	1124	0.29	0.39	1170	0.31	0.42	1216	0.34	0.46	1259	0.37	0.49	1300	0.40	0.53	1340	0.43	0.57	1379	0.46	0.61
519	1100	1089	0.30	0.40	1136	0.32	0.43	1181	0.34	0.46	1225	0.37	0.50	1268	0.40	0.54	1308	0.43	0.58	1347	0.46	0.62	1386	0.49	0.66
566	1200	1104	0.34	0.45	1150	0.36	0.48	1194	0.38	0.51	1237	0.41	0.55	1279	0.44	0.59	1319	0.47	0.63	1357	0.50	0.67	1394	0.53	0.71
613	1300	1121	0.37	0.50	1165	0.40	0.53	1209	0.43	0.57	1251	0.46	0.61	1292	0.48	0.65	1331	0.51	0.69	1368	0.54	0.73	1405	0.58	0.78
661	1400	1140	0.42	0.56	1183	0.44	0.59	1225	0.47	0.63	1266	0.50	0.67	1306	0.53	0.71	1345	0.57	0.76	1382	0.60	0.80	1417	0.63	0.85
708	1500	1161	0.46	0.62	1202	0.48	0.65	1243	0.51	0.69	1284	0.54	0.73	1323	0.58	0.78	1360	0.62	0.83	1396	0.65	0.87	1432	0.69	0.92

BLOWER DATA - BELT DRIVE - ZHB048 - DOWNFLOW

BLOWER TABLE INCLUDES RESISTANCE FOR BASE UNIT ONLY WITH DRY INDOOR COIL AND AIR FILTERS IN PLACE.
FOR ALL UNITS ADD:

1 - Any factory installed options air resistance (heat section, economizer, wet coil, etc.).

2 - Any field installed accessories air resistance (duct resistance, diffuser, etc.).

See page 33 for blower motors and drives and wet coil and options/accessory air resistance data.

Air Volume		External Static - Pa (in. w.g.)																							
		25 (0.10)		50 (0.20)		75 (0.30)		100 (0.40)		125 (0.50)		150 (0.60)		175 (0.70)		200 (0.80)									
L/s	cfm	Rev/ min	kW	BHP	Rev/ min	kW	BHP	Rev/ min	kW	BHP	Rev/ min	kW	BHP	Rev/ min	kW	BHP	Rev/ min	kW	BHP						
566	1200	620	0.17	0.23	681	0.22	0.29	744	0.25	0.34	809	0.29	0.39	875	0.32	0.43	941	0.35	0.47	1004	0.38	0.51	1060	0.40	0.54
613	1300	652	0.21	0.28	713	0.25	0.34	775	0.29	0.39	839	0.33	0.44	903	0.36	0.48	967	0.38	0.51	1025	0.41	0.55	1078	0.44	0.59
661	1400	687	0.25	0.33	747	0.29	0.39	809	0.33	0.44	871	0.37	0.49	934	0.40	0.53	994	0.43	0.57	1048	0.46	0.61	1098	0.48	0.64
708	1500	724	0.30	0.40	784	0.34	0.45	844	0.37	0.50	905	0.40	0.54	965	0.44	0.59	1021	0.46	0.62	1071	0.49	0.66	1118	0.52	0.70
755	1600	764	0.34	0.46	823	0.38	0.51	882	0.42	0.56	940	0.45	0.60	997	0.48	0.65	1048	0.51	0.69	1094	0.54	0.72	1140	0.56	0.75
802	1700	806	0.40	0.53	863	0.43	0.58	919	0.46	0.62	975	0.50	0.67	1028	0.53	0.71	1075	0.56	0.75	1119	0.58	0.78	1164	0.60	0.81
849	1800	849	0.45	0.60	903	0.48	0.65	957	0.51	0.69	1010	0.55	0.74	1058	0.58	0.78	1102	0.61	0.82	1145	0.63	0.85	1189	0.66	0.88
897	1900	892	0.51	0.68	944	0.54	0.72	995	0.57	0.77	1045	0.61	0.82	1089	0.64	0.86	1131	0.66	0.89	1174	0.69	0.92	1217	0.71	0.95
944	2000	935	0.57	0.76	984	0.60	0.81	1033	0.64	0.86	1079	0.68	0.91	1122	0.71	0.95	1163	0.72	0.97	1204	0.75	1.00	1247	0.77	1.03
Air Volume		External Static - Pa (in. w.g.)																							
		225 (0.90)		250 (1.00)		275 (1.10)		300 (1.20)		325 (1.30)		350 (1.40)		375 (1.50)		400 (1.60)									
L/s	cfm	Rev/ min	kW	BHP	Rev/ min	kW	BHP	Rev/ min	kW	BHP	Rev/ min	kW	BHP	Rev/ min	kW	BHP	Rev/ min	kW	BHP	Rev/ min	kW	BHP	Rev/ min	kW	BHP
566	1200	1111	0.43	0.58	1156	0.45	0.60	1199	0.46	0.62	1241	0.47	0.63	1284	0.48	0.65	1326	0.50	0.67	1367	0.53	0.71	1408	0.55	0.74
613	1300	1127	0.46	0.62	1172	0.48	0.65	1214	0.49	0.66	1256	0.51	0.68	1299	0.52	0.70	1341	0.54	0.73	1381	0.57	0.77	1421	0.60	0.81
661	1400	1145	0.51	0.68	1189	0.52	0.70	1231	0.54	0.72	1274	0.55	0.74	1316	0.57	0.76	1357	0.59	0.79	1397	0.62	0.83	1436	0.66	0.88
708	1500	1164	0.54	0.73	1208	0.56	0.75	1251	0.58	0.78	1293	0.60	0.80	1334	0.62	0.83	1374	0.64	0.86	1413	0.68	0.91	1451	0.71	0.95
755	1600	1185	0.59	0.79	1229	0.60	0.81	1271	0.63	0.84	1313	0.64	0.86	1354	0.67	0.90	1393	0.70	0.94	1431	0.73	0.98	1468	0.77	1.03
802	1700	1208	0.63	0.84	1252	0.65	0.87	1294	0.67	0.90	1335	0.70	0.94	1375	0.73	0.98	1413	0.76	1.02	1449	0.80	1.07	1485	0.84	1.12
849	1800	1233	0.68	0.91	1276	0.70	0.94	1318	0.73	0.98	1358	0.76	1.02	1397	0.79	1.06	1434	0.83	1.11	1469	0.87	1.16	1504	0.90	1.21
897	1900	1261	0.73	0.98	1303	0.76	1.02	1343	0.79	1.06	1382	0.83	1.11	1420	0.87	1.16	1455	0.90	1.21	1490	0.94	1.26	1525	0.98	1.31
944	2000	1289	0.80	1.07	1330	0.83	1.11	1370	0.87	1.16	1407	0.90	1.21	1444	0.95	1.27	1478	0.98	1.32	1513	1.02	1.37	1547	1.06	1.42

BLOWER DATA - BELT DRIVE - ZHBO48 - HORIZONTAL

BLOWER TABLE INCLUDES RESISTANCE FOR BASE UNIT ONLY WITH DRY INDOOR COIL AND AIR FILTERS IN PLACE.
FOR ALL UNITS ADD:

1 - Any factory installed options air resistance (heat section, economizer, wet coil, etc.).

2 - Any field installed accessories air resistance (duct resistance, diffuser, etc.).

See page 33 for blower motors and drives and wet coil and options/accessory air resistance data.

Air Volume		External Static - Pa (in. w.g.)																							
		25 (0.10)		50 (0.20)		75 (0.30)		100 (0.40)		125 (0.50)		150 (0.60)		175 (0.70)		200 (0.80)									
L/s	cfm	Rev/ min	kW	BHP	Rev/ min	kW	BHP	Rev/ min	kW	BHP	Rev/ min	kW	BHP	Rev/ min	kW	BHP	Rev/ min	kW	BHP						
566	1200	614	0.16	0.21	681	0.19	0.25	752	0.22	0.30	821	0.25	0.34	888	0.29	0.39	950	0.32	0.43	1006	0.34	0.46	1057	0.37	0.49
613	1300	644	0.18	0.24	712	0.22	0.29	782	0.25	0.34	850	0.29	0.39	915	0.32	0.43	974	0.35	0.47	1027	0.38	0.51	1076	0.40	0.53
661	1400	677	0.22	0.29	746	0.25	0.34	814	0.29	0.39	880	0.33	0.44	942	0.36	0.48	998	0.39	0.52	1049	0.41	0.55	1097	0.43	0.58
708	1500	714	0.25	0.34	781	0.30	0.40	848	0.34	0.45	911	0.37	0.49	970	0.40	0.53	1023	0.43	0.57	1072	0.45	0.60	1119	0.47	0.63
755	1600	752	0.30	0.40	818	0.34	0.45	882	0.37	0.50	943	0.41	0.55	999	0.44	0.59	1050	0.46	0.62	1097	0.49	0.66	1142	0.51	0.69
802	1700	792	0.34	0.46	855	0.39	0.52	917	0.42	0.56	975	0.46	0.61	1028	0.48	0.64	1077	0.51	0.68	1123	0.54	0.72	1166	0.56	0.75
849	1800	832	0.40	0.53	894	0.43	0.58	952	0.47	0.63	1007	0.50	0.67	1058	0.52	0.70	1105	0.55	0.74	1149	0.58	0.78	1192	0.61	0.82
897	1900	873	0.45	0.60	932	0.48	0.65	988	0.51	0.69	1040	0.54	0.73	1088	0.57	0.77	1134	0.60	0.81	1177	0.63	0.85	1219	0.67	0.90
944	2000	914	0.50	0.67	970	0.54	0.72	1023	0.57	0.76	1073	0.60	0.80	1120	0.63	0.85	1163	0.66	0.89	1205	0.70	0.94	1246	0.74	0.99

Air Volume		External Static - Pa (in. w.g.)																							
		225 (0.90)		250 (1.00)		275 (1.10)		300 (1.20)		325 (1.30)		350 (1.40)		375 (1.50)		400 (1.60)									
L/s	cfm	Rev/ min	kW	BHP	Rev/ min	kW	BHP	Rev/ min	kW	BHP	Rev/ min	kW	BHP	Rev/ min	kW	BHP	Rev/ min	kW	BHP						
566	1200	1105	0.38	0.51	1152	0.40	0.53	1197	0.41	0.55	1240	0.43	0.58	1280	0.46	0.61	1320	0.48	0.64	1358	0.51	0.68	1395	0.54	0.72
613	1300	1123	0.41	0.55	1169	0.43	0.57	1213	0.45	0.60	1255	0.47	0.63	1295	0.50	0.67	1334	0.52	0.70	1372	0.55	0.74	1409	0.59	0.79
661	1400	1142	0.45	0.60	1187	0.47	0.63	1230	0.49	0.66	1272	0.51	0.69	1312	0.54	0.73	1350	0.57	0.77	1388	0.61	0.82	1424	0.64	0.86
708	1500	1163	0.49	0.66	1207	0.51	0.69	1249	0.54	0.72	1290	0.57	0.76	1330	0.60	0.80	1368	0.63	0.85	1405	0.67	0.90	1441	0.70	0.94
755	1600	1185	0.54	0.72	1228	0.56	0.75	1270	0.59	0.79	1310	0.62	0.83	1349	0.66	0.88	1387	0.69	0.93	1423	0.73	0.98	1459	0.77	1.03
802	1700	1209	0.58	0.78	1251	0.61	0.82	1292	0.65	0.87	1331	0.69	0.92	1370	0.72	0.97	1407	0.76	1.02	1443	0.80	1.07	1478	0.84	1.12
849	1800	1234	0.64	0.86	1275	0.68	0.91	1315	0.72	0.96	1354	0.75	1.01	1391	0.79	1.06	1428	0.83	1.11	1463	0.87	1.17	1498	0.91	1.22
897	1900	1260	0.71	0.95	1300	0.75	1.00	1340	0.78	1.05	1377	0.83	1.11	1414	0.87	1.16	1450	0.91	1.22	1485	0.95	1.27	1519	0.98	1.32
944	2000	1287	0.78	1.04	1326	0.82	1.10	1365	0.87	1.16	1402	0.90	1.21	1437	0.95	1.27	1472	0.99	1.33	1507	1.03	1.38	1541	1.07	1.43

BLOWER DATA - BELT DRIVE - ZHBO60 - DOWNFLOW

BLOWER TABLE INCLUDES RESISTANCE FOR BASE UNIT ONLY WITH DRY INDOOR COIL AND AIR FILTERS IN PLACE.
FOR ALL UNITS ADD:

1 - Any factory installed options air resistance (heat section, economizer, wet coil, etc.).

2 - Any field installed accessories air resistance (duct resistance, diffuser, etc.).

See page 33 for blower motors and drives and wet coil and options/accessory air resistance data.

Air Volume		External Static - Pa (in. w.g.)																							
		25 (0.10)		50 (0.20)		75 (0.30)		100 (0.40)		125 (0.50)		150 (0.60)		175 (0.70)		200 (0.80)									
L/s	cfm	Rev/min	kW	BHP	Rev/min	kW	BHP	Rev/min	kW	BHP	Rev/min	kW	BHP	Rev/min	kW	BHP	Rev/min	kW	BHP						
755	1600	522	0.20	0.27	552	0.24	0.32	585	0.28	0.37	619	0.32	0.43	656	0.36	0.48	693	0.40	0.53	732	0.44	0.59	771	0.48	0.64
802	1700	539	0.24	0.32	570	0.28	0.37	603	0.32	0.43	638	0.36	0.48	674	0.40	0.53	711	0.44	0.59	749	0.48	0.64	787	0.51	0.69
849	1800	558	0.28	0.38	589	0.32	0.43	623	0.36	0.48	658	0.40	0.54	694	0.44	0.59	730	0.48	0.64	767	0.52	0.70	803	0.56	0.75
897	1900	578	0.33	0.44	610	0.37	0.49	643	0.40	0.54	678	0.45	0.60	714	0.48	0.65	749	0.52	0.70	785	0.57	0.76	819	0.61	0.82
944	2000	600	0.37	0.50	632	0.42	0.56	665	0.46	0.61	699	0.49	0.66	734	0.53	0.71	769	0.57	0.77	803	0.62	0.83	837	0.67	0.90
991	2100	623	0.43	0.57	655	0.46	0.62	688	0.51	0.68	721	0.54	0.73	755	0.59	0.79	789	0.63	0.84	822	0.68	0.91	854	0.73	0.98
1038	2200	647	0.48	0.65	678	0.52	0.70	711	0.56	0.75	743	0.60	0.81	776	0.64	0.86	809	0.69	0.93	841	0.75	1.00	872	0.79	1.06
1085	2300	671	0.54	0.73	702	0.58	0.78	734	0.62	0.83	766	0.66	0.89	798	0.71	0.95	829	0.76	1.02	860	0.81	1.09	890	0.87	1.16
1133	2400	696	0.60	0.81	726	0.65	0.87	757	0.69	0.92	788	0.73	0.98	819	0.78	1.04	850	0.83	1.11	880	0.89	1.19	909	0.94	1.26

Air Volume		External Static - Pa (in. w.g.)																							
		225 (0.90)		250 (1.00)		275 (1.10)		300 (1.20)		325 (1.30)		350 (1.40)		375 (1.50)		400 (1.60)									
L/s	cfm	Rev/min	kW	BHP	Rev/min	kW	BHP	Rev/min	kW	BHP	Rev/min	kW	BHP	Rev/min	kW	BHP	Rev/min	kW	BHP						
755	1600	809	0.51	0.69	844	0.55	0.74	877	0.60	0.80	908	0.63	0.85	936	0.68	0.91	963	0.72	0.97	989	0.76	1.02	1014	0.81	1.08
802	1700	823	0.56	0.75	857	0.60	0.80	889	0.64	0.86	919	0.69	0.92	947	0.72	0.97	973	0.77	1.03	999	0.81	1.09	1024	0.85	1.14
849	1800	838	0.60	0.81	870	0.65	0.87	901	0.69	0.92	931	0.73	0.98	958	0.78	1.04	984	0.82	1.10	1009	0.87	1.16	1034	0.91	1.22
897	1900	853	0.66	0.88	885	0.70	0.94	915	0.74	0.99	944	0.78	1.05	971	0.83	1.11	996	0.87	1.17	1021	0.92	1.23	1045	0.96	1.29
944	2000	869	0.72	0.96	899	0.75	1.01	929	0.80	1.07	957	0.84	1.13	984	0.89	1.19	1009	0.93	1.25	1033	0.98	1.31	1058	1.03	1.38
991	2100	885	0.78	1.04	915	0.82	1.10	944	0.86	1.15	971	0.91	1.22	997	0.95	1.28	1022	1.00	1.34	1046	1.04	1.40	1070	1.09	1.46
1038	2200	902	0.84	1.13	931	0.89	1.19	959	0.93	1.24	986	0.98	1.31	1012	1.02	1.37	1036	1.07	1.43	1060	1.12	1.50	1084	1.16	1.56
1085	2300	920	0.92	1.23	948	0.96	1.29	975	1.01	1.35	1001	1.05	1.41	1027	1.10	1.47	1051	1.14	1.53	1075	1.19	1.60	1098	1.24	1.66
1133	2400	938	0.99	1.33	965	1.04	1.39	992	1.08	1.45	1017	1.13	1.52	1042	1.18	1.58	1066	1.22	1.64	1090	1.27	1.70	1113	1.32	1.77

BLOWER DATA - BELT DRIVE - ZHBO60 - HORIZONTAL

BLOWER TABLE INCLUDES RESISTANCE FOR BASE UNIT ONLY WITH DRY INDOOR COIL AND AIR FILTERS IN PLACE.
FOR ALL UNITS ADD:

1 - Any factory installed options air resistance (heat section, economizer, wet coil, etc.).

2 - Any field installed accessories air resistance (duct resistance, diffuser, etc.).

See page 33 for blower motors and drives and wet coil and options/accessory air resistance data.

Air Volume		External Static - Pa (in. w.g.)																							
		25 (0.10)		50 (0.20)		75 (0.30)		100 (0.40)		125 (0.50)		150 (0.60)		175 (0.70)		200 (0.80)									
L/s	cfm	Rev/ min	kW	BHP	Rev/ min	kW	BHP	Rev/ min	kW	BHP	Rev/ min	kW	BHP	Rev/ min	kW	BHP	Rev/ min	kW	BHP						
755	1600	525	0.22	0.30	561	0.25	0.34	597	0.29	0.39	635	0.32	0.43	673	0.35	0.47	711	0.38	0.51	748	0.42	0.56	784	0.46	0.61
802	1700	543	0.25	0.34	578	0.29	0.39	615	0.32	0.43	653	0.36	0.48	691	0.39	0.52	728	0.43	0.57	765	0.46	0.62	800	0.50	0.67
849	1800	561	0.29	0.39	597	0.33	0.44	635	0.37	0.49	672	0.40	0.53	710	0.43	0.58	746	0.47	0.63	782	0.51	0.68	816	0.54	0.73
897	1900	581	0.33	0.44	618	0.37	0.49	655	0.40	0.54	692	0.44	0.59	729	0.48	0.64	765	0.51	0.69	800	0.56	0.75	833	0.60	0.80
944	2000	602	0.37	0.50	639	0.41	0.55	676	0.46	0.61	713	0.49	0.66	749	0.53	0.71	784	0.57	0.76	818	0.61	0.82	850	0.66	0.88
991	2100	625	0.43	0.57	661	0.46	0.62	698	0.50	0.67	735	0.54	0.73	770	0.58	0.78	804	0.63	0.84	837	0.67	0.90	868	0.72	0.96
1038	2200	648	0.48	0.64	685	0.51	0.69	721	0.56	0.75	757	0.60	0.80	791	0.64	0.86	824	0.69	0.92	856	0.73	0.98	886	0.78	1.05
1085	2300	673	0.53	0.71	709	0.57	0.77	745	0.62	0.83	780	0.66	0.88	813	0.70	0.94	845	0.75	1.01	876	0.81	1.08	905	0.86	1.15
1133	2400	699	0.59	0.79	734	0.63	0.85	769	0.68	0.91	803	0.72	0.97	835	0.78	1.04	866	0.83	1.11	896	0.88	1.18	924	0.93	1.25

Air Volume		External Static - Pa (in. w.g.)																							
		225 (0.90)		250 (1.00)		275 (1.10)		300 (1.20)		325 (1.30)		350 (1.40)		375 (1.50)		400 (1.60)									
L/s	cfm	Rev/ min	kW	BHP	Rev/ min	kW	BHP	Rev/ min	kW	BHP	Rev/ min	kW	BHP	Rev/ min	kW	BHP	Rev/ min	kW	BHP						
755	1600	819	0.49	0.66	851	0.54	0.72	883	0.57	0.77	913	0.62	0.83	943	0.66	0.89	971	0.71	0.95	998	0.75	1.01	1024	0.80	1.07
802	1700	833	0.54	0.72	865	0.58	0.78	896	0.63	0.84	926	0.67	0.90	954	0.72	0.96	982	0.76	1.02	1009	0.81	1.08	1034	0.85	1.14
849	1800	848	0.59	0.79	880	0.63	0.85	910	0.69	0.92	939	0.73	0.98	967	0.78	1.04	994	0.82	1.10	1020	0.87	1.16	1045	0.92	1.23
897	1900	864	0.65	0.87	895	0.69	0.93	924	0.74	0.99	953	0.79	1.06	980	0.84	1.12	1007	0.88	1.18	1032	0.93	1.25	1056	0.98	1.31
944	2000	881	0.71	0.95	911	0.75	1.01	940	0.81	1.08	967	0.85	1.14	994	0.90	1.21	1020	0.95	1.27	1044	1.00	1.34	1068	1.04	1.40
991	2100	898	0.77	1.03	927	0.82	1.10	955	0.87	1.17	982	0.92	1.23	1008	0.97	1.30	1033	1.02	1.37	1057	1.07	1.43	1080	1.12	1.50
1038	2200	916	0.84	1.12	944	0.89	1.19	971	0.94	1.26	998	0.99	1.33	1023	1.04	1.40	1047	1.10	1.47	1071	1.15	1.54	1093	1.19	1.60
1085	2300	934	0.91	1.22	961	0.96	1.29	988	1.01	1.36	1014	1.07	1.43	1038	1.12	1.50	1062	1.18	1.58	1085	1.23	1.65	1107	1.28	1.71
1133	2400	952	0.98	1.32	979	1.04	1.40	1005	1.10	1.47	1030	1.15	1.54	1054	1.21	1.62	1077	1.26	1.69	1099	1.31	1.76	1121	1.37	1.83

BLOWER DATA - BELT DRIVE - ZHB072 - DOWNFLOW

BLOWER TABLE INCLUDES RESISTANCE FOR BASE UNIT ONLY WITH DRY INDOOR COIL AND AIR FILTERS IN PLACE.
FOR ALL UNITS ADD:

1 - Any factory installed options air resistance (heat section, economizer, wet coil, etc.).

2 - Any field installed accessories air resistance (duct resistance, diffuser, etc.).

See page 33 for blower motors and drives and wet coil and options/accessory air resistance data.

Air Volume		External Static - Pa (in. w.g.)																							
		25 (0.10)		50 (0.20)		75 (0.30)		100 (0.40)		125 (0.50)		150 (0.60)		175 (0.70)		200 (0.80)									
L/s	cfm	Rev/ min	kW	BHP	Rev/ min	kW	BHP	Rev/ min	kW	BHP	Rev/ min	kW	BHP	Rev/ min	kW	BHP	Rev/ min	kW	BHP						
850	1800	558	0.28	0.38	589	0.32	0.43	623	0.36	0.48	658	0.40	0.54	694	0.44	0.59	730	0.48	0.64	767	0.52	0.70	803	0.56	0.75
895	1900	578	0.33	0.44	610	0.37	0.49	643	0.40	0.54	678	0.45	0.60	714	0.48	0.65	749	0.52	0.70	785	0.57	0.76	819	0.61	0.82
945	2000	600	0.37	0.50	632	0.42	0.56	665	0.46	0.61	699	0.49	0.66	734	0.53	0.71	769	0.57	0.77	803	0.62	0.83	837	0.67	0.90
990	2100	623	0.43	0.57	655	0.46	0.62	688	0.51	0.68	721	0.54	0.73	755	0.59	0.79	789	0.63	0.84	822	0.68	0.91	854	0.73	0.98
1040	2200	647	0.48	0.65	678	0.52	0.70	711	0.56	0.75	743	0.60	0.81	776	0.64	0.86	809	0.69	0.93	841	0.75	1.00	872	0.79	1.06
1085	2300	671	0.54	0.73	702	0.58	0.78	734	0.62	0.83	766	0.66	0.89	798	0.71	0.95	829	0.76	1.02	860	0.81	1.09	890	0.87	1.16
1135	2400	696	0.60	0.81	726	0.65	0.87	757	0.69	0.92	788	0.73	0.98	819	0.78	1.04	850	0.83	1.11	880	0.89	1.19	909	0.94	1.26
1180	2500	720	0.67	0.90	750	0.71	0.95	780	0.75	1.01	811	0.80	1.07	841	0.85	1.14	871	0.91	1.22	900	0.97	1.30	929	1.02	1.37
1225	2600	745	0.74	0.99	774	0.78	1.05	804	0.83	1.11	834	0.87	1.17	864	0.93	1.25	893	0.99	1.33	921	1.05	1.41	949	1.11	1.49
1275	2700	770	0.81	1.09	799	0.86	1.15	828	0.90	1.21	858	0.95	1.28	887	1.01	1.36	916	1.07	1.44	943	1.14	1.53	969	1.20	1.61
1320	2800	795	0.89	1.19	824	0.93	1.25	853	0.99	1.33	882	1.04	1.40	911	1.10	1.48	939	1.16	1.56	965	1.23	1.65	990	1.29	1.73
1370	2900	820	0.97	1.30	849	1.02	1.37	878	1.08	1.45	907	1.14	1.53	935	1.20	1.61	962	1.27	1.70	988	1.33	1.78	1012	1.39	1.86
Air Volume		225 (0.90)		250 (1.00)		275 (1.10)		300 (1.20)		325 (1.30)		350 (1.40)		375 (1.50)		400 (1.60)									
		Rev/ min	kW	BHP	Rev/ min	kW	BHP	Rev/ min	kW	BHP	Rev/ min	kW	BHP	Rev/ min	kW	BHP	Rev/ min	kW	BHP						
850	1800	838	0.60	0.81	870	0.65	0.87	901	0.69	0.92	931	0.73	0.98	958	0.78	1.04	984	0.82	1.10	1009	0.87	1.16	1034	0.91	1.22
895	1900	853	0.66	0.88	885	0.70	0.94	915	0.74	0.99	944	0.78	1.05	971	0.83	1.11	996	0.87	1.17	1021	0.92	1.23	1045	0.96	1.29
945	2000	869	0.72	0.96	899	0.75	1.01	929	0.80	1.07	957	0.84	1.13	984	0.89	1.19	1009	0.93	1.25	1033	0.98	1.31	1058	1.03	1.38
990	2100	885	0.78	1.04	915	0.82	1.10	944	0.86	1.15	971	0.91	1.22	997	0.95	1.28	1022	1.00	1.34	1046	1.04	1.40	1070	1.09	1.46
1040	2200	902	0.84	1.13	931	0.89	1.19	959	0.93	1.24	986	0.98	1.31	1012	1.02	1.37	1036	1.07	1.43	1060	1.12	1.50	1084	1.16	1.56
1085	2300	920	0.92	1.23	948	0.96	1.29	975	1.01	1.35	1001	1.05	1.41	1027	1.10	1.47	1051	1.14	1.53	1075	1.19	1.60	1098	1.24	1.66
1135	2400	938	0.99	1.33	965	1.04	1.39	992	1.08	1.45	1017	1.13	1.52	1042	1.18	1.58	1066	1.22	1.64	1090	1.27	1.70	1113	1.32	1.77
1180	2500	956	1.07	1.44	983	1.13	1.51	1009	1.17	1.57	1034	1.22	1.63	1059	1.26	1.69	1082	1.31	1.75	1105	1.36	1.82	1128	1.40	1.88
1225	2600	975	1.16	1.56	1001	1.22	1.63	1026	1.26	1.69	1051	1.31	1.75	1075	1.35	1.81	1098	1.40	1.87	1121	1.44	1.93	1143	1.49	2.00
1275	2700	995	1.25	1.68	1020	1.31	1.75	1044	1.35	1.81	1069	1.40	1.87	1092	1.44	1.93	1114	1.48	1.99	1136	1.54	2.06	1158	1.59	2.13
1320	2800	1015	1.35	1.81	1039	1.40	1.87	1063	1.45	1.94	1086	1.49	2.00	1109	1.54	2.06	1131	1.58	2.12	1152	1.63	2.19	1174	1.69	2.26
1370	2900	1035	1.45	1.94	1058	1.49	2.00	1081	1.54	2.07	1104	1.59	2.13	1126	1.63	2.19	1147	1.69	2.26	1168	1.74	2.33	1189	1.79	2.40

BLOWER DATA - BELT DRIVE - ZHB072 - HORIZONTAL

BLOWER TABLE INCLUDES RESISTANCE FOR BASE UNIT ONLY WITH DRY INDOOR COIL AND AIR FILTERS IN PLACE.
FOR ALL UNITS ADD:

1 - Any factory installed options air resistance (heat section, economizer, wet coil, etc.).

2 - Any field installed accessories air resistance (duct resistance, diffuser, etc.).

See page 33 for blower motors and drives and wet coil and options/accessory air resistance data.

Air Volume		External Static - Pa (in. w.g.)																							
		25 (0.10)			50 (0.20)			75 (0.30)			100 (0.40)			125 (0.50)			150 (0.60)			175 (0.70)			200 (0.80)		
L/s	cfm	Rev/ min	BHP	kW	Rev/ min	BHP	kW	Rev/ min	BHP	kW	Rev/ min	BHP	kW	Rev/ min	BHP	kW	Rev/ min	BHP	kW	Rev/ min	BHP	kW	Rev/ min	BHP	kW
850	1800	561	0.29	0.33	597	0.39	0.44	635	0.37	0.49	672	0.40	0.53	710	0.43	0.58	746	0.47	0.63	782	0.51	0.68	816	0.54	0.73
895	1900	581	0.33	0.37	618	0.44	0.49	655	0.40	0.54	692	0.44	0.59	729	0.48	0.64	765	0.51	0.69	800	0.56	0.75	833	0.60	0.80
945	2000	602	0.37	0.41	639	0.50	0.55	676	0.46	0.61	713	0.49	0.66	749	0.53	0.71	784	0.57	0.76	818	0.61	0.82	850	0.66	0.88
990	2100	625	0.43	0.46	661	0.57	0.62	698	0.50	0.67	735	0.54	0.73	770	0.58	0.78	804	0.63	0.84	837	0.67	0.90	868	0.72	0.96
1040	2200	648	0.48	0.51	685	0.64	0.69	721	0.56	0.75	757	0.60	0.80	791	0.64	0.86	824	0.69	0.92	856	0.73	0.98	886	0.78	1.05
1085	2300	673	0.53	0.57	709	0.71	0.77	745	0.62	0.83	780	0.66	0.88	813	0.70	0.94	845	0.75	1.01	876	0.81	1.08	905	0.86	1.15
1135	2400	699	0.59	0.63	734	0.79	0.85	769	0.68	0.91	803	0.72	0.97	835	0.78	1.04	866	0.83	1.11	896	0.88	1.18	924	0.93	1.25
1180	2500	725	0.66	0.68	759	0.88	0.94	793	0.75	1.00	826	0.80	1.07	857	0.85	1.14	887	0.90	1.21	916	0.95	1.28	944	1.01	1.36
1225	2600	752	0.72	0.78	785	0.97	1.04	818	0.82	1.10	850	0.87	1.17	880	0.93	1.25	909	0.98	1.32	937	1.04	1.40	964	1.10	1.48
1275	2700	779	0.80	0.85	811	1.07	1.14	843	0.90	1.21	873	0.96	1.29	902	1.02	1.37	931	1.07	1.44	958	1.13	1.52	984	1.19	1.60
1320	2800	805	0.88	0.94	837	1.18	1.26	868	0.99	1.33	897	1.05	1.41	925	1.11	1.49	952	1.17	1.57	979	1.24	1.66	1004	1.30	1.74
1370	2900	832	0.97	1.03	863	1.30	1.38	892	1.09	1.46	921	1.15	1.54	948	1.22	1.63	974	1.28	1.71	1000	1.34	1.80	1024	1.40	1.88
Air Volume		225 (0.90)			250 (1.00)			275 (1.10)			300 (1.20)			325 (1.30)			350 (1.40)			375 (1.50)			400 (1.60)		
		Rev/ min	BHP	kW	Rev/ min	BHP	kW	Rev/ min	BHP	kW	Rev/ min	BHP	kW	Rev/ min	BHP	kW	Rev/ min	BHP	kW	Rev/ min	BHP	kW	Rev/ min	BHP	kW
850	1800	848	0.59	0.79	880	0.63	0.85	910	0.69	0.92	939	0.73	0.98	967	0.78	1.04	994	0.82	1.10	1020	0.87	1.16	1045	0.92	1.23
895	1900	864	0.65	0.87	895	0.69	0.93	924	0.74	0.99	953	0.79	1.06	980	0.84	1.12	1007	0.88	1.18	1032	0.93	1.25	1056	0.98	1.31
945	2000	881	0.71	0.95	911	0.75	1.01	940	0.81	1.08	967	0.85	1.14	994	0.90	1.21	1020	0.95	1.27	1044	1.00	1.34	1068	1.04	1.40
990	2100	898	0.77	1.03	927	0.82	1.10	955	0.87	1.17	982	0.92	1.23	1008	0.97	1.30	1033	1.02	1.37	1057	1.07	1.43	1080	1.12	1.50
1040	2200	916	0.84	1.12	944	0.89	1.19	971	0.94	1.26	998	0.99	1.33	1023	1.04	1.40	1047	1.10	1.47	1071	1.15	1.54	1093	1.19	1.60
1085	2300	934	0.91	1.22	961	0.96	1.29	988	1.01	1.36	1014	1.07	1.43	1038	1.12	1.50	1062	1.18	1.58	1085	1.23	1.65	1107	1.28	1.71
1135	2400	952	0.98	1.32	979	1.04	1.40	1005	1.10	1.47	1030	1.15	1.54	1054	1.21	1.62	1077	1.26	1.69	1099	1.31	1.76	1121	1.37	1.83
1180	2500	971	1.07	1.43	997	1.13	1.51	1022	1.19	1.59	1046	1.24	1.66	1069	1.30	1.74	1092	1.35	1.81	1114	1.40	1.88	1135	1.45	1.95
1225	2600	990	1.16	1.55	1015	1.22	1.63	1039	1.28	1.71	1063	1.34	1.79	1086	1.39	1.86	1108	1.45	1.94	1129	1.50	2.01	1150	1.54	2.07
1275	2700	1009	1.25	1.68	1034	1.31	1.76	1057	1.37	1.84	1080	1.43	1.92	1102	1.48	1.99	1124	1.54	2.07	1145	1.60	2.14	1166	1.65	2.21
1320	2800	1028	1.36	1.82	1052	1.42	1.90	1075	1.48	1.98	1097	1.54	2.06	1119	1.59	2.13	1140	1.65	2.21	1161	1.70	2.28	1182	1.75	2.34
1370	2900	1048	1.46	1.96	1071	1.52	2.04	1093	1.58	2.12	1115	1.64	2.20	1136	1.70	2.28	1157	1.75	2.35	1177	1.81	2.42	1198	1.85	2.48

BLOWER DATA

DRIVE KIT SPECIFICATIONS - ZHA/ZHB 036-060

Model No.	Motor kW (HP)		No. of Speeds	Drive Kits and Rev/Min Range					
	Nominal	Maximum		ZA07	ZA08	ZA09	ZA10	¹ ZA11	² ZA12
ZHA/ZHB 036	0.62 (0.83)	0.71 (0.95)	1	705 - 1077	---	---	---	---	---
	0.93 (1.25)	1.07 (1.43)	1	---	---	---	1025 - 1391	---	---
ZHA/ZHB 048	0.62 (0.83)	0.71 (0.95)	1	---	759 - 1158	---	---	---	---
	0.93 (1.25)	1.07 (1.43)	1	---	---	---	---	1111 - 1437	---
ZHA060	0.93 (1.25)	1.07 (1.43)	1	---	---	919 - 1247	---	---	---
	1.24 (1.66)	1.42 (1.91)	1	---	---	---	---	---	1190 - 1540

NOTE - Using total air volume and system static pressure requirements determine from blower performance tables rev/min and motor size required. Maximum usable size of motors furnished are shown. If motors of comparable size are used, be sure to keep within the service factor limitations outlined on the motor nameplate.

¹ ZA11 drive kits require the 0.93 kW (1.25 hp) motor.

² ZA12 drive kit requires the 1.24 kW (1.66 hp) motor.

DRIVE KIT SPECIFICATIONS - ZHB060-072

Model No.	Motor kW (HP)		No. of Speeds	Drive Kits and Rev/Min Range			
	Nominal	Maximum		ZAA02	ZAA03	ZAA04	ZAA05
ZHB060	0.93 (1.25)	1.07 (1.43)	1	527 - 729	---	---	---
	1.24 (1.66)	1.42 (1.91)	1	---	665 - 921	768 - 1023	---
ZHB072	0.93 (1.25)	1.07 (1.43)	1	---	665 - 921	768 - 1023	---
	1.24 (1.66)	1.42 (1.91)	1	---	665 - 921	768 - 1023	921 - 1177

NOTE - Using total air volume and system static pressure requirements determine from blower performance tables rev/min and motor size required. Maximum usable size of motors furnished are shown. If motors of comparable size are used, be sure to keep within the service factor limitations outlined on the motor nameplate.

OPTIONS / ACCESSORIES AIR RESISTANCE

Air Volume		Wet Indoor Coil								Electric Heat		Economizer			
		ZHA036, ZHA048		ZHA060, ZHB036		ZHB048, ZHB060		ZHB072				Downflow		Horizontal	
L/s	cfm	Pa	in. w.g.	Pa	in. w.g.	Pa	in. w.g.	Pa	in. w.g.	Pa	in. w.g.	Pa	in. w.g.	Pa	in. w.g.
425	900	2	0.01	2	0.01	---	---	---	---	12	0.05	7	0.03	10	0.04
472	1000	5	0.02	2	0.01	---	---	---	---	15	0.06	7	0.03	12	0.05
519	1100	5	0.02	5	0.02	---	---	---	---	20	0.08	10	0.04	12	0.05
566	1200	5	0.02	5	0.02	2	0.01	---	---	22	0.09	12	0.05	15	0.06
613	1300	7	0.03	5	0.02	5	0.02	---	---	30	0.12	12	0.05	17	0.07
661	1400	7	0.03	7	0.03	5	0.02	---	---	42	0.17	15	0.06	20	0.08
708	1500	10	0.04	7	0.03	5	0.02	---	---	55	0.22	17	0.07	20	0.08
755	1600	10	0.04	7	0.03	7	0.03	7	0.03	65	0.26	20	0.08	22	0.09
802	1700	12	0.05	10	0.04	7	0.03	7	0.03	75	0.30	22	0.09	25	0.10
849	1800	12	0.05	10	0.04	7	0.03	7	0.03	82	0.33	25	0.10	27	0.11
897	1900	15	0.06	12	0.05	10	0.04	10	0.04	82	0.33	27	0.11	30	0.12
944	2000	15	0.06	12	0.05	10	0.04	10	0.04	77	0.31	30	0.12	32	0.13
991	2100	---	---	15	0.06	12	0.05	12	0.05	67	0.27	32	0.13	35	0.14
1038	2200	---	---	15	0.06	12	0.05	12	0.05	72	0.29	35	0.14	37	0.15
1085	2300	---	---	17	0.07	12	0.05	12	0.05	77	0.31	37	0.15	40	0.16
1133	2400	---	---	17	0.07	15	0.06	15	0.06	80	0.32	40	0.16	45	0.18
1180	2500	---	---	---	---	---	---	15	0.06	85	0.34	45	0.18	47	0.19
1227	2600	---	---	---	---	---	---	17	0.07	94	0.38	47	0.19	50	0.20
1274	2700	---	---	---	---	---	---	17	0.07	104	0.42	50	0.20	52	0.21
1321	2800	---	---	---	---	---	---	17	0.07	112	0.45	55	0.22	57	0.23
1369	2900	---	---	---	---	---	---	20	0.08	122	0.49	57	0.23	60	0.24

BLOWER DATA

POWER EXHAUST FAN PERFORMANCE

Return Air System Static Pressure		Air Volume Exhausted	
Pa	in. w.g.	L/s	cfm
0	0.00	880	1865
12	0.05	842	1785
25	0.10	807	1710
37	0.15	769	1630
50	0.20	729	1545
62	0.25	684	1450
75	0.30	637	1350
87	0.35	585	1240

CEILING DIFFUSERS AIR RESISTANCE

Air Volume		RTD9-65S Step-Down Diffuser						FD9-65S Flush Diffuser		RTD11-95S Step-Down Diffuser						FD11-95S Flush Diffuser	
		2 Ends Open		1 Side & 2 Ends Open		All Ends & Sides Open				2 Ends Open		1 Side & 2 Ends Open		All Ends & Sides Open			
L/s	cfm	Pa	in. w.g.	Pa	in. w.g.	Pa	in. w.g.	Pa	in. w.g.	Pa	in. w.g.	Pa	in. w.g.	Pa	in. w.g.	Pa	in. w.g.
375	800	37	0.15	32	0.13	27	0.11	27	0.11	---	---	---	---	---	---	---	---
470	1000	47	0.19	40	0.16	35	0.14	35	0.14	---	---	---	---	---	---	---	---
565	1200	62	0.25	50	0.20	42	0.17	42	0.17	---	---	---	---	---	---	---	---
660	1400	82	0.33	65	0.26	50	0.20	50	0.20	---	---	---	---	---	---	---	---
755	1600	107	0.43	80	0.32	50	0.20	50	0.24	---	---	---	---	---	---	---	---
850	1800	139	0.56	99	0.40	75	0.30	75	0.30	32	0.13	27	0.11	22	0.09	22	0.09
945	2000	182	0.73	124	0.50	90	0.36	90	0.36	37	0.15	32	0.13	27	0.11	25	0.10
1040	2200	236	0.95	157	0.63	109	0.44	109	0.44	45	0.18	37	0.15	30	0.12	30	0.12
1130	2400	---	---	---	---	---	---	---	---	52	0.21	45	0.18	37	0.15	35	0.14
1225	2600	---	---	---	---	---	---	---	---	60	0.24	52	0.21	45	0.18	42	0.17
1320	2800	---	---	---	---	---	---	---	---	67	0.27	60	0.24	52	0.21	50	0.20
1415	3000	---	---	---	---	---	---	---	---	80	0.32	72	0.29	62	0.25	62	0.25
1510	3200	---	---	---	---	---	---	---	---	102	0.41	92	0.37	80	0.32	77	0.31
1605	3400	---	---	---	---	---	---	---	---	124	0.50	112	0.45	97	0.39	92	0.37
1700	3600	---	---	---	---	---	---	---	---	152	0.61	134	0.54	119	0.48	109	0.44

CEILING DIFFUSER AIR THROW DATA

Air Volume		1 Effective Throw			
Model No.		RTD9-65S		FD9-65S	
L/s	cfm	m	ft.	m	ft.
375	800	3 - 5	10 - 17	4 - 5	14 - 18
470	1000	3 - 5	10 - 17	5 - 6	15 - 20
565	1200	3 - 5	11 - 18	5 - 7	16 - 22
660	1400	4 - 6	12 - 19	5 - 7	17 - 24
755	1600	4 - 6	12 - 20	5 - 8	18 - 25
850	1800	4 - 6	13 - 21	6 - 9	20 - 28
945	2000	4 - 7	14 - 23	6 - 9	21 - 29
1040	2200	5 - 8	16 - 25	7 - 9	22 - 30
Model No.		RTD11-95S		FD11-95S	
1225	2600	7 - 9	24 - 29	6 - 7	19 - 24
1320	2800	8 - 9	25 - 30	6 - 9	20 - 28
1415	3000	8 - 10	27 - 33	6 - 9	21 - 29
1510	3200	9 - 11	28 - 35	7 - 9	22 - 29
1605	3400	9 - 11	30 - 37	7 - 9	22 - 30
1700	3600	8 - 10	25 - 33	7 - 8	22 - 24

¹ Effective throw based on terminal velocities of 23 m per minute (75 ft. per minute).

ELECTRICAL/ELECTRIC HEAT DATA - ZHA

		ZHA036S4		ZHA048S4		ZHA060S4	
¹ Voltage - 50hz with Neutral		380/420V - 3 Ph		380/420V - 3 Ph		380/420V - 3 Ph	
Compressor	Rated Load Amps	4		5.5		8	
	Locked Rotor Amps	31		37		59	
Outdoor Fan Motor	Full Load Amps	0.9		0.9		1	
Power Exhaust (1) 0.37 kW	Full Load Amps	0.6		0.6		0.6	
Indoor Blower Motor	kW	0.62	0.93	0.62	0.93	0.93	1.24
	Full Load Amps	1.5	2	1.6	2	2	2.9
² Maximum Overcurrent Protection	Unit Only	15	15	15	15	20	20
	With (1) 0.37 kW Power Exhaust	15	15	15	15	20	20
³ Minimum Circuit Ampacity	Unit Only	8	8	10	10	13	14
	With (1) 0.37 kW Power Exhaust	9	9	10	11	14	15

ELECTRIC HEAT DATA

Electric Heat Voltage			420V	420V	420V	420V	420V	420V
² Maximum Overcurrent Protection	Unit+ ⁴ Electric Heat	3.8 kW	15	15	20	20	25	25
		5.7 kW	20	20	20	20	25	25
		7.7 kW	25	25	25	25	30	30
		11.5 kW	30	30	30	30	35	35
		17.2 kW	---	---	40	40	45	45
³ Minimum Circuit Ampacity	Unit+ ⁴ Electric Heat	3.8 kW	15	15	16	17	20	21
		5.7 kW	18	18	20	20	23	24
		7.7 kW	21	22	23	23	27	28
		11.5 kW	28	28	30	30	33	34
		17.2 kW	---	---	39	40	43	44
² Maximum Overcurrent Protection	Unit+ ⁴ Electric Heat and (1) 0.37 kW Power Exhaust	3.8 kW	15	20	20	20	25	25
		5.7 kW	20	20	20	25	25	30
		7.7 kW	25	25	25	25	30	30
		11.5 kW	30	30	30	35	35	35
		17.2 kW	---	---	40	40	45	45
³ Minimum Circuit Ampacity	Unit+ ⁴ Electric Heat and (1) 0.37 kW Power Exhaust	3.8 kW	15	16	17	17	21	22
		5.7 kW	18	19	20	21	24	25
		7.7 kW	22	22	24	24	27	28
		11.5 kW	28	29	30	31	34	35
		17.2 kW	---	---	40	40	44	45

ELECTRIC HEAT ACCESSORIES

Unit Fuse Block	Unit Only	10A29	10A29	10A29	10A29	10A29	10A29
	Unit + Power Exhaust	10A29	10A29	10A29	10A29	10A29	10A29

¹ Extremes of operating range are plus and minus 10% of line voltage.

² Heating, Air Conditioning, Refrigeration type breaker or fuse.

³ Refer to local electrical code to determine wire, fuse and disconnect size requirements.

⁴ Nominal kW based on 420V-3ph-50hz.

ELECTRICAL/ELECTRIC HEAT DATA - ZHB

		ZHB036S4		ZHB048S4		ZHB060S4		ZHB072S4	
¹ Voltage - 50hz with Neutral		380/420V - 3 Ph		380/420V - 3 Ph		380/420V - 3 Ph		380/420V - 3 Ph	
Compressor	Rated Load Amps	4		5.5		8		10.6	
	Locked Rotor Amps	31		37		59		74	
Outdoor Fan Motor	Full Load Amps	0.6		0.9		1		1.3	
Power Exhaust (1) 0.37 kW	Full Load Amps	0.6		0.6		0.6		0.6	
Indoor Blower Motor	kW	0.62	0.93	0.62	0.93	0.93	1.24	0.93	1.24
	Full Load Amps	1.6	2	1.6	2	2	2.9	2	2.9
² Maximum Overcurrent Protection	Unit Only	15	15	15	15	20	20	25	25
	With (1) 0.37 kW Power Exhaust	15	15	15	15	20	20	25	25
³ Minimum Circuit Ampacity	Unit Only	8	8	10	10	13	14	17	18
	With (1) 0.37 kW Power Exhaust	8	8	10	11	14	15	18	19

ELECTRIC HEAT DATA

Electric Heat Voltage			420V	420V	420V	420V	420V	420V	420V	420V
² Maximum Overcurrent Protection	⁴ Electric Heat	Unit+ 3.8 kW	15	15	20	20	25	25	---	---
		5.7 kW	20	20	20	20	25	25	35	35
		7.7 kW	25	25	25	25	30	30	35	35
		11.5 kW	30	30	30	30	35	35	40	40
		17.2 kW	---	---	40	40	45	45	50	50
		23 kW	---	---	---	---	---	---	60	60
³ Minimum Circuit Ampacity	⁴ Electric Heat	Unit+ 3.8 kW	14	15	16	17	20	21	---	---
		5.7 kW	18	18	20	20	23	24	27	28
		7.7 kW	21	21	23	23	27	28	30	31
		11.5 kW	27	28	30	30	33	34	37	38
		17.2 kW	---	---	39	40	43	44	47	48
		23 kW	---	---	---	---	---	---	57	57
² Maximum Overcurrent Protection	⁴ Electric Heat and (1) 0.37 Power Exhaust	Unit+ 3.8 kW	15	15	20	20	25	25	---	---
		5.7 kW	20	20	20	25	25	30	35	35
		7.7 kW	25	25	25	25	30	30	35	35
		11.5 kW	30	30	30	35	35	35	40	40
		17.2 kW	---	---	40	40	45	45	50	50
		23 kW	---	---	---	---	---	---	60	60
³ Minimum Circuit Ampacity	⁴ Electric Heat and (1) 0.37 Power Exhaust	Unit+ 3.8 kW	15	15	17	17	21	22	---	---
		5.7 kW	18	19	20	21	24	25	28	28
		7.7 kW	21	22	24	24	27	28	31	32
		11.5 kW	28	28	30	31	34	35	37	38
		17.2 kW	---	---	40	40	44	45	47	48
		23 kW	---	---	---	---	---	---	57	58

ELECTRIC HEAT ACCESSORIES

Unit Fuse Block	Unit Only	10A29	10A29	10A29	10A29	10A29	10A29	10A29	10A29
	Unit + Power Exhaust	10A29	10A29	10A29	10A29	10A29	10A29	10A29	10A29

¹ Extremes of operating range are plus and minus 10% of line voltage.

² Heating, Air Conditioning, Refrigeration type breaker or fuse.

³ Refer to local electrical code to determine wire, fuse and disconnect size requirements.

⁴ Nominal kW based on 420V-3ph-50hz.

ELECTRIC HEAT CAPACITIES

Input Voltage	3.8 kW			5.7 kW			7.7 kW		
	No of Stages	kW input	Btuh Output	No of Stages	kW input	Btuh Output	No of Stages	kW input	Btuh Output
380	1	3.1	10 700	1	4.7	16 000	1	6.3	21 400
400	1	3.5	11 800	1	5.2	17 800	1	6.9	23 700
420	1	3.8	13 100	1	5.7	19 600	1	7.7	26 100
Input Voltage	11.5 kW			17.2 kW			23 kW		
	No of Stages	kW input	Btuh Output	No of Stages	kW input	Btuh Output	No of Stages	kW input	Btuh Output
380	1	9.4	32 100	1	14.1	48 100	1	18.8	64 200
400	1	10.4	35 500	1	15.6	53 300	1	20.9	71 400
420	1	11.5	39 200	1	17.2	58 800	1	23.0	78 500

OUTDOOR SOUND DATA

Unit Model No.	Octave Band Sound Power Levels dBA, re 10 ⁻¹² Watts - Center Frequency - Hz							1 Sound Rating Number (dBA)
	125	250	500	1000	2000	4000	8000	
ZHA036	82	79	78	74	70	66	61	79
ZHA048	82	79	78	74	70	66	61	79
ZHA060	86	83	82	77	73	70	67	83
ZHB036	82	79	78	74	70	66	61	79
ZHB048	77	77	76	72	67	63	57	77
ZHB060	85	81	81	76	71	69	67	82
ZHB072	85	85	84	80	75	72	70	86

¹ Sound Rating Number according to AHRI Standard 270-2008. Sound Rating Number is the overall A-Weighted Sound Power Level, (LWA), dBA (100 Hz to 10,000 Hz).

UNIT CLEARANCES

UNIT WITH DOWNFLOW ECONOMIZER

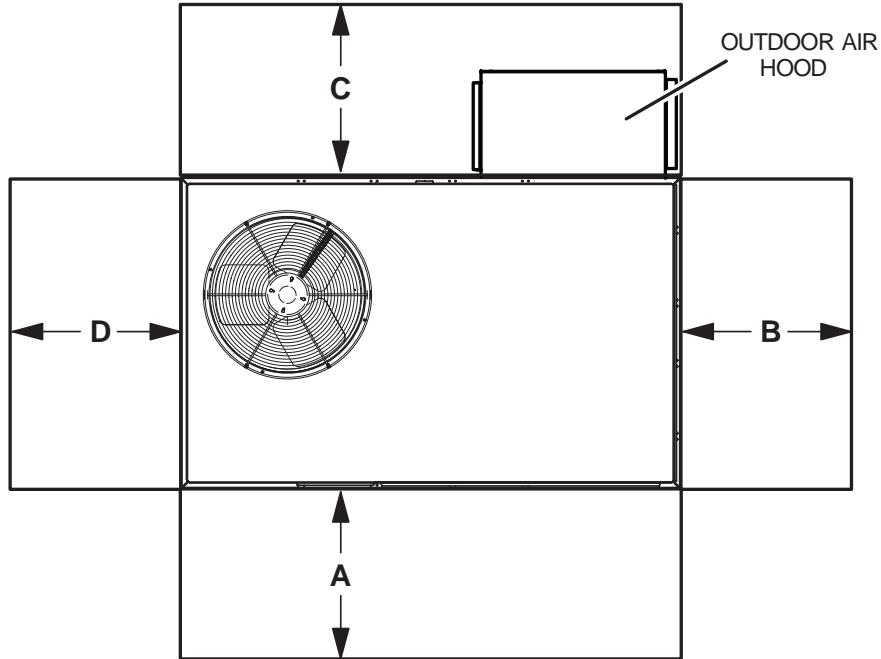

UNIT WITH HORIZONTAL ECONOMIZER

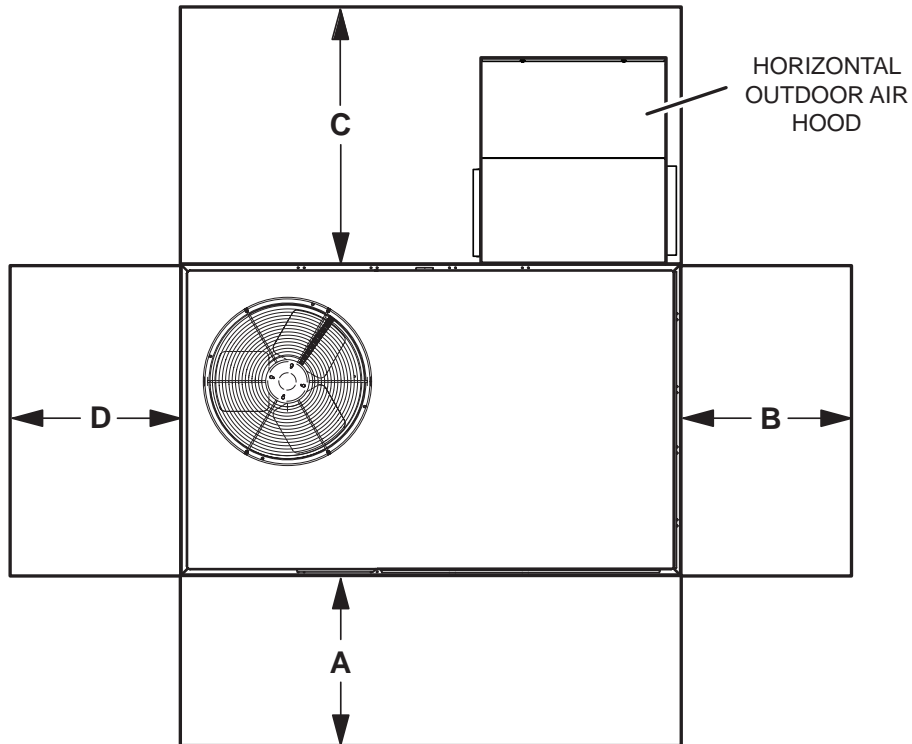

¹ Unit Clearance	A		B		C Downflow		C Horizontal		D		Top Clearance
	mm	in.	mm	in.	mm	in.	mm	in.	mm	in.	
Service Clearance	914	36	914	36	914	36	1524	60	914	36	Unobstructed
Minimum Operation Clearance	914	36	914	36	914	36	1524	60	914	36	

NOTE - Entire perimeter of unit base requires support when elevated above the mounting surface.

¹ Service Clearance - Required for removal of serviceable parts.

Minimum Operation Clearance - Required clearance for proper unit operation.

OPTIONAL CONVENTIONAL TEMPERATURE CONTROL SYSTEMS

Item	Model No.	Catalog No.
<p>7-DAY PROGRAMMABLE THERMOSTAT - BACNET COMPATIBLE WITH REHEAT FUNCTION</p>  <ul style="list-style-type: none"> • For units with or without ¹ Dehumidification Option • BTL listed MS/TP ensures compatibility with any BACnet system • Built-in control programs for conventional and heat pump applications • Conventional systems up to 3-stage heat and 3-stage cool • Heat pumps with 1 or 2 compressors and up to 2-stage auxiliary heat • On-board temperature and humidity sensor • Multiple configurable inputs and outputs enable advanced control strategies • Set-up Wizard enables rapid system configuration • No special tools required for installation or commissioning • Seven-day (2, 4 or 6 event) occupancy scheduling per day • Backlit 5-inch LCD touchscreen 	---	Y8241

¹ BACnet Thermostat (Y8241) will control units with and without dehumidification. If there is a mix of units equipped with and without dehumidification on the same site, this thermostat can be used for all units if desired.

BACnet Controls (no reheat capability)	BACnet® Module (factory or field installed)	K0CTRL31A-2	16X70
	BACnet® Room Sensor with Display (field installed)	K0SNSR01FF1	97W23
	BACnet® Room Sensor without Display (field installed)	K0SNSR00FF1	97W24
Optional Accessories	Plenum Cable (RJ45/CAT5 75 ft.)	K0MISC00FF1	97W25

WEIGHT DATA

Model Number	Net				Shipping			
	Base		Max.		Base		Max.	
	kg	lbs.	kg	lbs.	kg	lbs.	kg	lbs.
ZHA036S	240	530	264	581	243	535	266	586
ZHB036S	263	580	288	634	265	585	290	639
ZHA048S	244	539	268	590	247	544	270	595
ZHB048S	265	585	290	639	268	590	292	644
ZHA060S	265	585	290	639	268	590	292	644
ZHB060S	277	610	301	664	279	615	303	669
ZHB072S	310	683	318	702	324	715	333	735

Base Unit - The unit with NO OPTIONS.

Max. Unit - The unit with ALL OPTIONS Installed. (Economizer, etc.)

OPTIONS / ACCESSORIES

		Shipping Weights	
		kg	lbs.
ECONOMIZER			
Economizer			
Economizer, Includes Outdoor Air Hood and Barometric Relief Dampers with Hood	Downflow	34	75
	Horizontal	46	102
OUTDOOR AIR			
Outdoor Air Dampers			
Motorized		18	39
Manual		13	29
POWER EXHAUST			
Standard Static	Downflow	24	54
	Horizontal	19	41
ELECTRIC HEAT			
	3.8 kW	11	25
	5.7 kW	12	26
	7.7 kW	12	27
	11.5 kW	12	27
	17.2 kW	13	29
	23 kW	14	30
ROOF CURBS			
Hybrid Roof Curbs, Downflow			
203 mm height	Z1CURB70A-1	29	63
356 mm height	Z1CURB71A-1	38	83
457 mm height	Z1CURB72A-1	42	93
610 mm height	Z1CURB73A-1	51	113
CEILING DIFFUSERS			
Step-Down	RTD9-65S	36	80
	RTD11-95S	54	118
Flush	FD9-65S	36	80
	FD11-95S	54	118

DIMENSIONS - UNIT - ZHA

Model No.	CORNER WEIGHTS																CENTER OF GRAVITY							
	AA				BB				CC				DD				EE				FF			
	Base		Max.		Base		Max.		Base		Max.		Base		Max.		Base		Max.		Base		Max.	
	kg	lbs.	kg	lbs.	kg	lbs.	kg	lbs.	kg	lbs.	kg	lbs.	kg	lbs.	kg	lbs.	mm	in.	mm	in.	mm	in.	mm	in.
036	62	136	69	152	57	126	71	157	58	129	62	138	63	139	61	134	1003	39.5	953	37.5	591	23.25	635	25.0
048	63	139	70	155	58	128	72	159	59	131	63	140	64	142	62	136	1003	39.5	953	37.5	591	23.25	635	25.0
060	78	172	86	190	63	139	77	171	56	123	60	132	69	151	67	147	1067	42.0	1016	40.0	635	25.00	673	26.5

Base Unit - The unit with NO OPTIONS.

Max. Unit - The unit with ALL OPTIONS Installed. (Economizer, largest blower motor, etc.).

BOTTOM POWER ENTRY

Holes required for Optional Bottom Power Entry Kit

	Threaded Conduit Fittings (Provided in Kit)	Wire Use	Hole Diameter Required in Unit Base (Max.)
A	1/2	ACC	23 (7/8)
B	1/2	24V	23 (7/8)
C	3/4	POWER	29 (1-1/8)

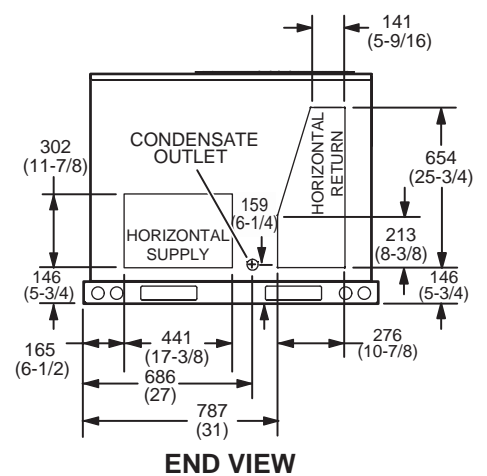
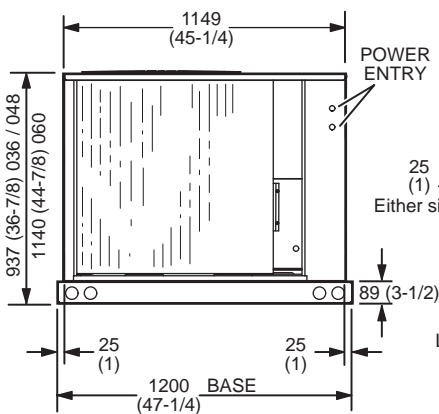
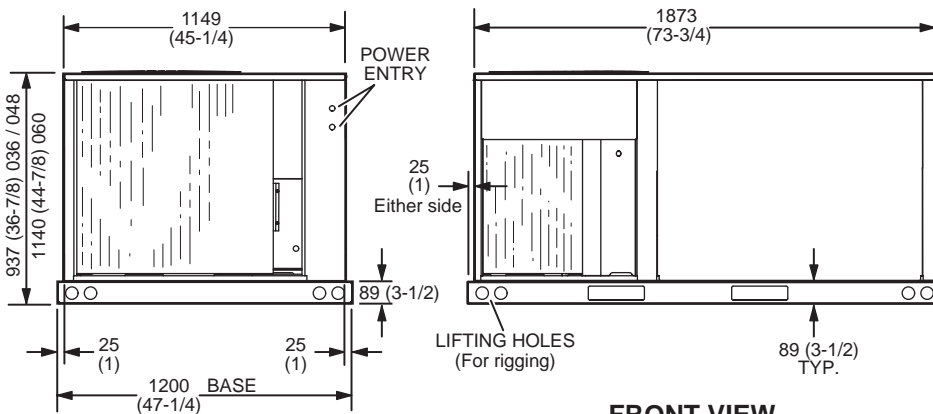
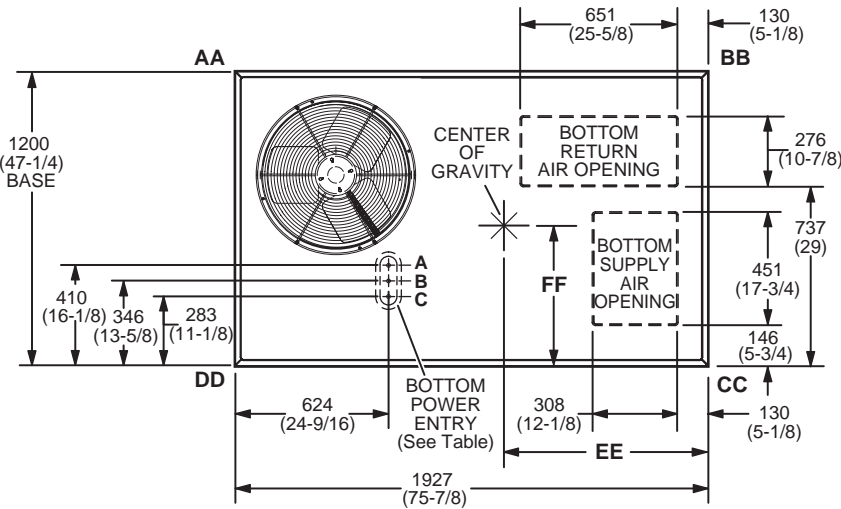

DIMENSIONS - UNIT - ZHB

Model No.	CORNER WEIGHTS																CENTER OF GRAVITY							
	AA				BB				CC				DD				EE				FF			
	Base		Max.		Base		Max.		Base		Max.		Base		Max.		Base		Max.		Base		Max.	
	kg	lbs.	kg	lbs.	kg	lbs.	kg	lbs.	kg	lbs.	kg	lbs.	kg	lbs.	mm	in.	mm	in.	mm	in.	mm	in.	mm	in.
036	72	158	78	173	60	133	66	145	56	124	61	135	67	147	73	160	1048	41.25	997	39.25	622	24.5	654	25.75
048	76	168	83	183	62	136	67	148	54	120	59	130	67	148	73	161	1067	42	1016	40	635	25	673	26.5
060	74	163	80	177	64	142	70	155	64	142	70	155	74	163	80	177	1029	40.5	978	38.5	597	23.5	635	25
072	68	149	65	143	91	200	91	200	87	191	95	209	65	143	68	150	1067	42	1041	41	610	24	584	23

Base Unit - The unit with NO OPTIONS.

Max. Unit - The unit with ALL OPTIONS Installed. (Economizer, largest blower motor, etc.)

BOTTOM POWER ENTRY

Holes required for Optional Bottom Power Entry Kit

	Threaded Conduit Fittings (Provided in Kit)	Wire Use	Hole Diameter Required in Unit Base (Max.)
E	1/2	ACC	23 (7/8)
F	1/2	24V	23 (7/8)
G	3/4	POWER	29 (1-1/8)

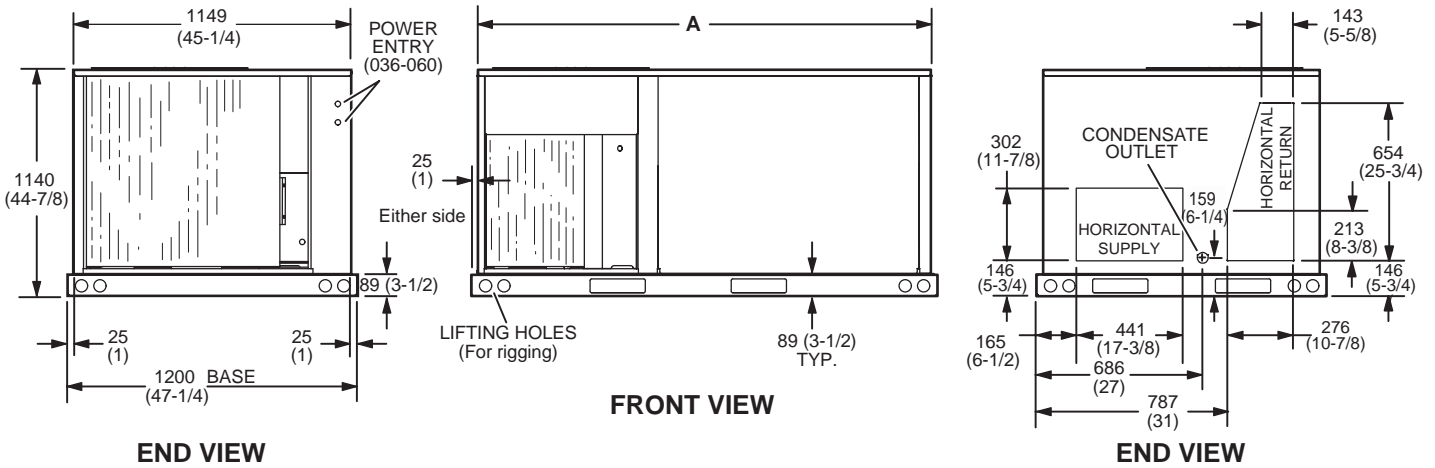
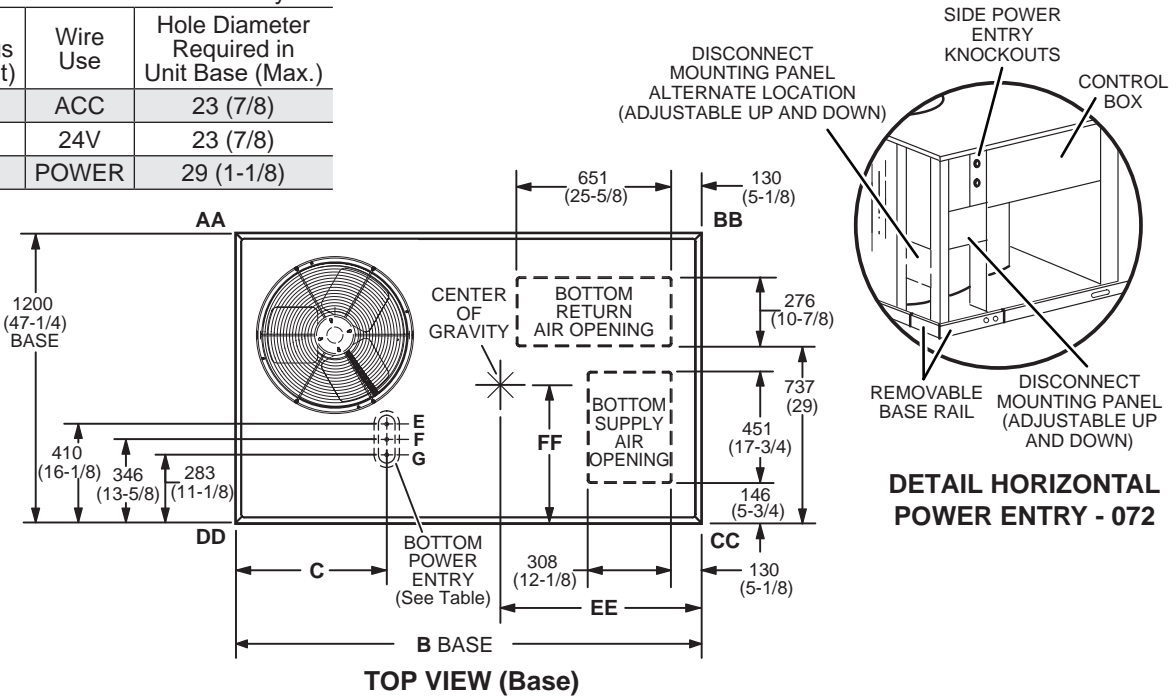

Model Number	A		B		C	
	mm	in.	mm	in.	mm	in.
ZHB036, 048	1873	73-3/4	1927	75-7/8	625	24-5/8
ZHB060	1873	73-3/4	1927	75-7/8	625	24-5/8
ZHB072	2115	83-1/4	2165	85-1/4	864	34

DIMENSIONS - ACCESSORIES

OUTDOOR AIR HOOD DETAIL FOR OPTIONAL ECONOMIZER (Downflow Applications)

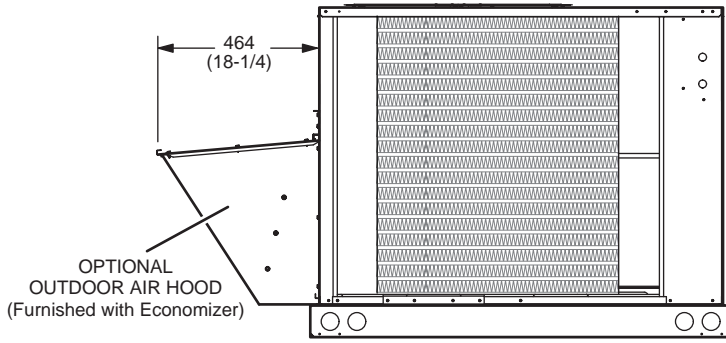

SIDE VIEW

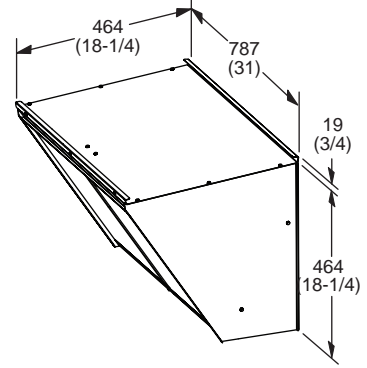

OUTDOOR AIR DAMPER HOOD DETAIL (Downflow or Horizontal Applications)

MANUAL OUTDOOR AIR HOOD

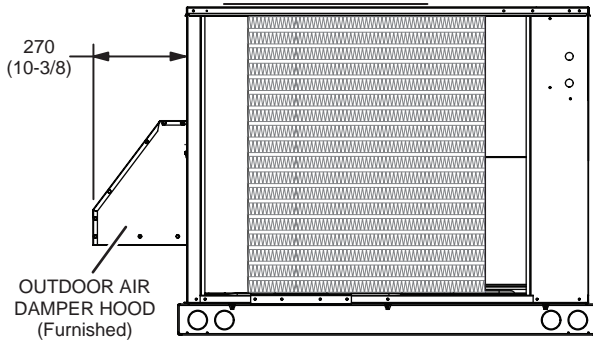

END VIEW

MOTORIZED OUTDOOR AIR HOOD

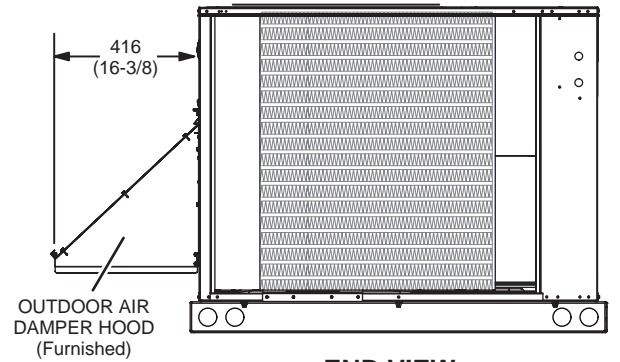

END VIEW

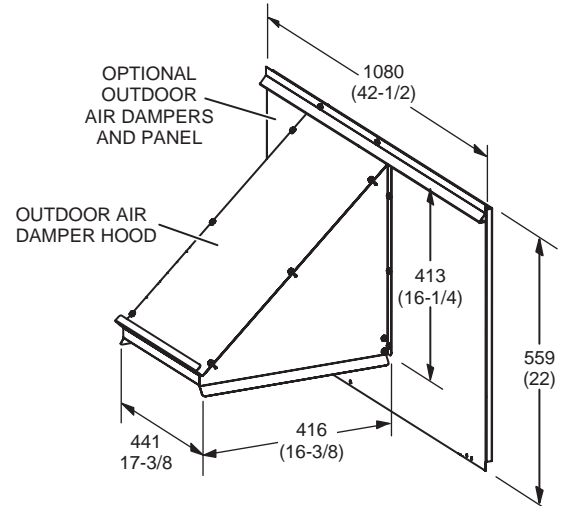
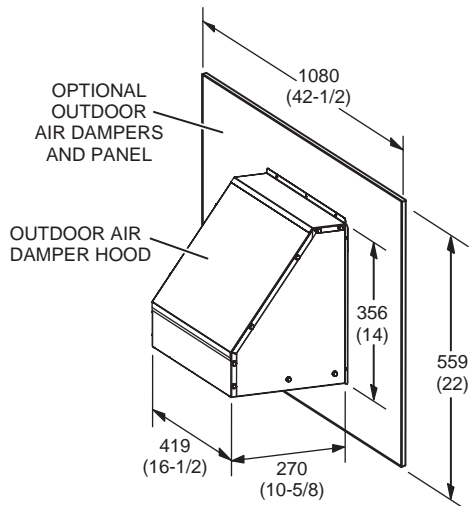

DIMENSIONS - ACCESSORIES

OUTDOOR AIR HOOD DETAIL WITH OPTIONAL ECONOMIZER AND BAROMETRIC RELIEF DAMPERS (Horizontal Applications)

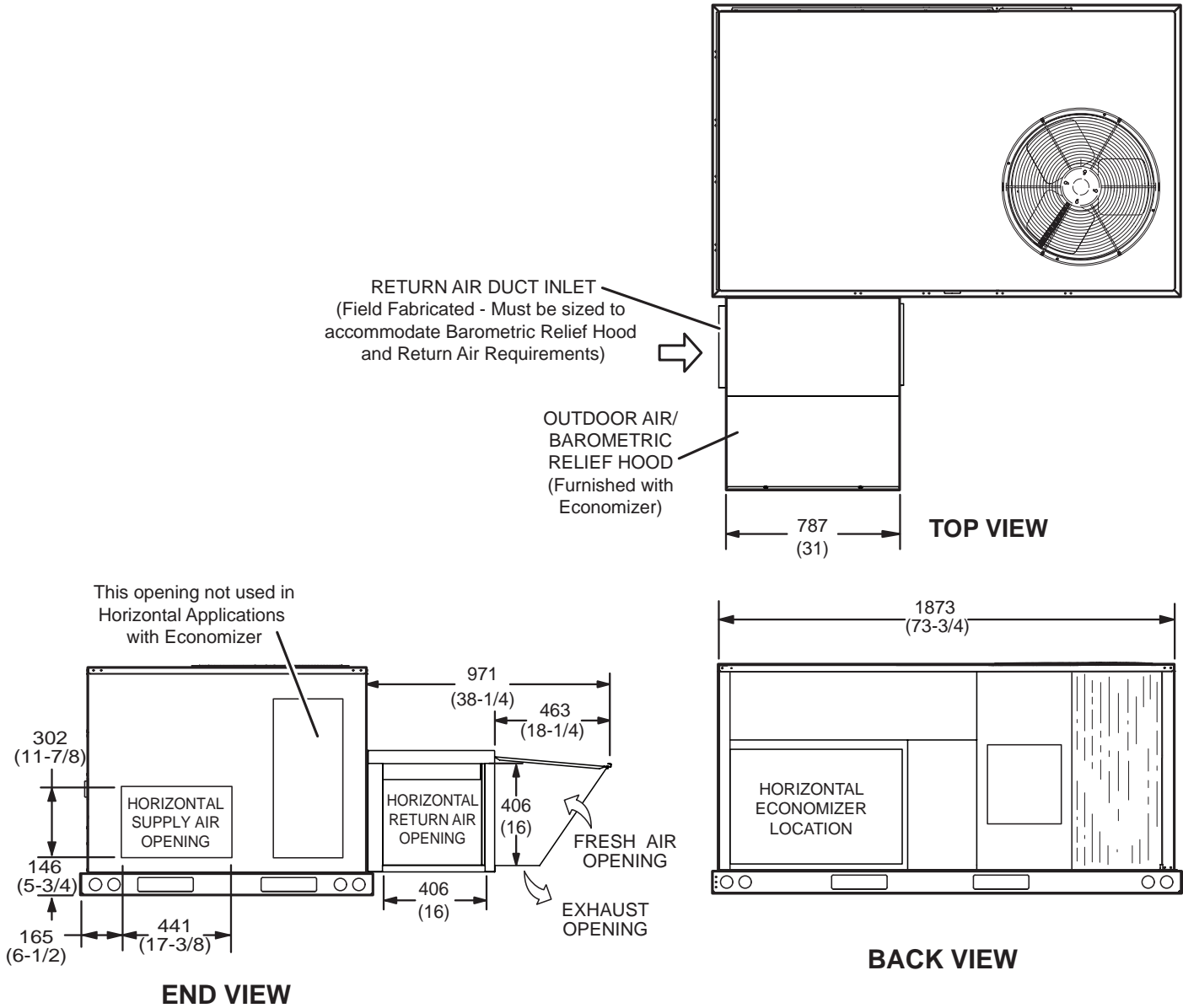

Note - Return Air Duct and Transition must be supported.

DIMENSIONS - ACCESSORIES

HYBRID ROOF CURBS - DOUBLE DUCT OPENING

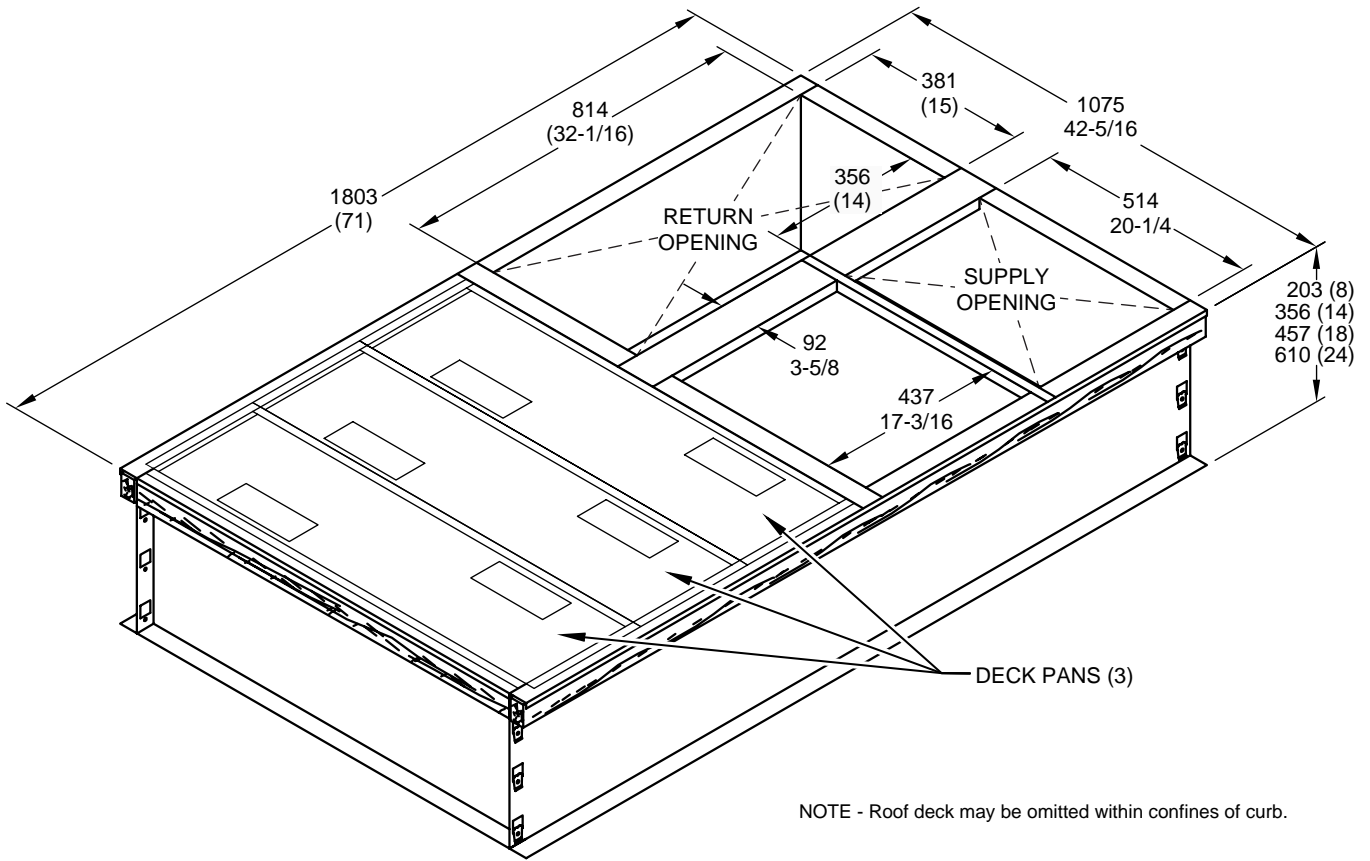

TYPICAL FLASHING DETAIL FOR ROOF CURB

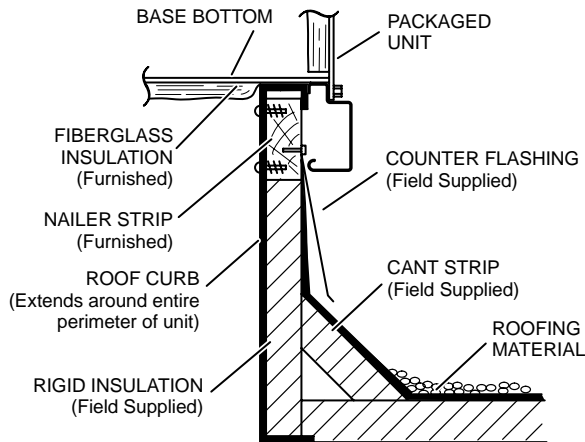

DETAIL ROOF CURB

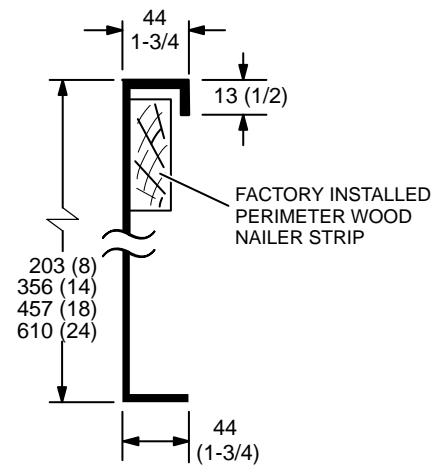

DIMENSIONS - ACCESSORIES

COMBINATION CEILING SUPPLY AND RETURN DIFFUSERS

STEP-DOWN CEILING DIFFUSER

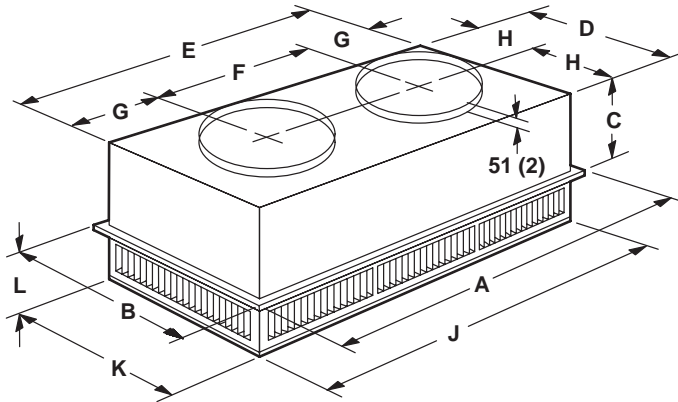

FLUSH CEILING DIFFUSER

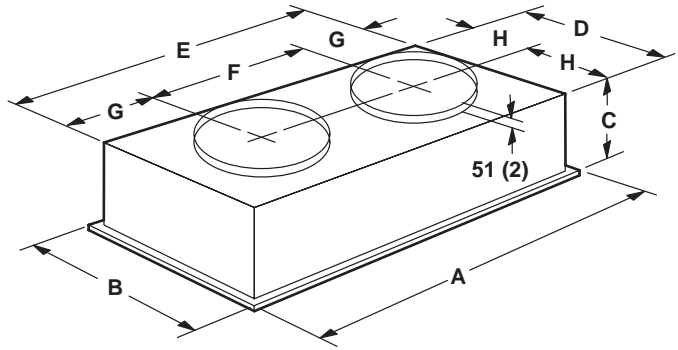

Model Number		RTD9-65S	RTD11-95S
A	mm	1159	1159
	in.	47-5/8	47-5/8
B	mm	600	752
	in.	23-5/8	29-5/8
C	mm	289	365
	in.	11-3/8	14-3/8
D	mm	546	699
	in.	21-1/2	27-1/2
E	mm	1156	1158
	in.	45-1/2	45-1/2
F	mm	572	572
	in.	22-1/2	22-1/2
G	mm	292	292
	in.	11-1/2	11-1/2
H	mm	273	349
	in.	10-3/4	13-3/4
J	mm	1156	1156
	in.	45-1/2	45-1/2
K	mm	546	699
	in.	21-1/2	27-1/2
L	mm	181	206
	in.	7-1/8	8-1/8
Duct Size	mm	457 round	508 round
	in.	18 round	20 round

Model Number		FD9-65S	FD11-95S
A	mm	1159	1159
	in.	47-5/8	47-5/8
B	mm	600	752
	in.	23-5/8	29-5/8
C	mm	343	422
	in.	13-1/2	16-5/8
D	mm	533	686
	in.	21	27
E	mm	1143	1143
	in.	45	45
F	mm	572	572
	in.	22-1/2	22-1/2
G	mm	286	286
	in.	11-1/4	11-1/4
H	mm	267	343
	in.	10-1/2	13-1/2
Duct Size	mm	457 round	508 round
	in.	18 round	20 round

REVISIONS

Section	Description
Optional Conventional Temperature Control Systems	Added BACnet Thermostat, Controls and optional accessories.



Visit us at www.allied-commercial.com

For the latest technical information, visit us at www.allied-commercial.com

Contact us at 1-800-738-4000

NOTE - Due to Allied Commercial ongoing commitment to quality, Specifications, Ratings and Dimensions subject to change without notice and without incurring liability. Improper installation, adjustment, alteration, service or maintenance can cause property damage or personal injury. Installation and service must be performed by a qualified installer and servicing agency.

©2019 Allied Air Enterprises LLC, a Lennox International Inc. Company