

**INSTALLATION INSTRUCTIONS FOR GERMICIDAL LIGHT KIT C1UVCL10A-2 (21A92; 106881-01)
USED WITH LG/LC/LH/KG/KC/KH 024-074 UNITS**

⚠ WARNING

Improper installation, adjustment, alteration, service or maintenance can cause property damage, personal injury or loss of life. Installation and service must be performed by a licensed professional installer (or equivalent), service agency or the gas supplier.

⚠ WARNING  

WARNING UV LIGHT SOURCE

Ultraviolet (UVC) Radiation Hazard.

This cover is provided with an Interlock to reduce the risk of ultraviolet radiation exposure. Any exposure will cause eye and skin damage. Do not look into UV light source. Access panels must be in place during appliance operation. Disconnect all power sources from UV Light, the Air Handling Equipment or Duct System.

Shipping & Packing List

Package 1 of 1 contains the following:

- 1 - Germicidal light
 - 1- UVC light assembly
 - 1- UVC lamp
 - 1- UVC light shield (triangular)
 - 1- Ballast
 - 1- Ballast bracket
- 13- Convoluted tubing (varying lengths)
- 1 - Bag assembly containing:
 - 1- Warranty sheet
 - 1- UVC Danger label
- 53- Wire ties
- 8- #10-16 x 5/8" sheet metal screws
- 1- #10-32 x 1/2" green ground screw
- 2- Dual quick connect adapters
- 2- Wire harnesses
- 2- Wiring diagrams
- 1- Door switch
- 1- Door bracket
- 2- #10-32 x 1/2" Self drilling screws
- 1- UVC field kit label

An additional, separately ordered T49 transformer is required on LCH/KC/KH, 460/575V units which do NOT have a T3 transformer (unless powered directly).

NOTE - Not all components provided in kit are used in each application.

Check packaging for shipping damage. Contact the last carrier immediately if any shipping damage is found.

⚠ CAUTION

As with any mechanical equipment, contact with sharp sheet metal edges can result in personal injury. Take care while handling this equipment and wear gloves and protective clothing.

General

Germicidal lights emit ultraviolet (UVC) energy that has been proven effective in reducing microbial life forms (viruses, bacteria, yeasts, and molds) in the air.

UVC germicidal lamps greatly reduce the growth and proliferation of mold and other bio-aerosols (bacteria and viruses) on illuminated surfaces.

Germicidal lamps are NOT intended to be used for removal of active mold growth. Existing mold growth must be appropriately removed PRIOR to installation of the germicidal lamp.

A door switch is provided which de-energizes the UVC light when the door is opened.

IMPORTANT - Cotton gloves or a cotton cloth must be used when handling the new UVC lamp.

Application

The UVC light kit is specifically designed for LG/LC/KG/KC/KH 024-074 units. In addition, the light is equipped with shields to focus the UVC light on the coil surface where it is needed and reduce the exposure of light on other components and access panels for improved safety and overall effectiveness.

Enhanced rapid start ballast provides UVC lamp operation at a full range of operating conditions. LED's on ballast show lamp operation status:

Green LED indicates power on.

Blue LED indicates lamp operation.

Lamps operate on 110-230V single-phase power supply. Alternately, 110V power supply may be used to directly power the UVC ballast(s). Be sure to wire the interlock door switch which interrupts power to the UVC light; see Ballast Supply Cable section.

⚠ WARNING

Potential Mold Spore Release.

Application of UVC lamps to existing mold growth can cause respiratory irritation and allergic symptoms.

Do not use UVC lamps where active mold growth exists. Remove active mold growth from surfaces prior to operation of UVC lamps.



NOTICE

Potential odor emissions.

Odors may be present when some materials are exposed to UV light.

These materials may include Technicoated or E-Coated Coils. Other materials may include chemicals, solvents, polymers and organic materials.

Some occupants may notice irritation or discomfort.

If odors are present, the UV Lights should be turned off and fresh air should be introduced into the occupied space immediately. Contact your Independent Lennox Dealer.

⚠ CAUTION

Potential Risk of Degradation of Materials.

Potential of degraded wire insulation may cause human injury through electrical shock.

UVC light may damage plastics and rubber materials. May cause fabric discoloration.

Avoid UVC light exposure to plastic drain pans, wire insulation, flex duct or other plastic/rubber components.

Before installation, confirm that any corrosion-resistant coating (if applied to the coil) will not be negatively impacted by the UVC light exposure.

Specifications

| | |
|--|---|
| Enhanced ballast dimension | 11.75" L x 2.75" W x 1.625" H (298mm x 70mm x 42mm) |
| Lamp assembly dimension | 40.75" L x 2" W x 2.75" H (1035mm x 51mm x 60mm) |
| Triangular sheet metal panel dimension | 30" L x 12" W x 1" H (762mm x 305mm x 25mm) |
| Electrical power supply | 110/230V, 50/60Hz, 0.5A |

NOTE - For 460V & 575V LGH, LCH, KG, KC and KH units, order separate step-down T49 transformers.

| | |
|-------------------|----------|
| Power consumption | 51 Watts |
|-------------------|----------|

Lamp/Ballast Operating Environment (All models)

| | |
|--------------------------------|------------------------------|
| Temperature (outside of duct): | 5°F to 140°F (-15°C to 60°C) |
| Relative humidity | <95%. |

Listings:

ETL Safety Listing File #2002554

This device complies with FCC - CFR47 Part 18 Consumer (Class A and B).

FIFRA (Federal Insecticide Fungicide Rodenticide Act) - File No. 73316.

U.S. Patent Nos: (PENDING)

Specifications subject to change without notice.

| Part No. | Replacement Part Description |
|----------|------------------------------|
|----------|------------------------------|

| | |
|-------|------------------|
| 50W91 | UVC lamp |
| 50W92 | Enhanced ballast |

Before Installation

- Turn off power to the rooftop unit.
- Open access to the control box, blower compartment and the filter section.

⚠ WARNING



Electric shock hazard.

Can cause injury or death.

Disconnect all remote power supplies before opening any unit access panels.

Unit may have multiple power supplies.

Do not operate without access panels in place.

UVC Exposure Protection

The UVC light is equipped with a unique directional shield to focus the UVC light on the coil surface and drain pan where it is needed and reduce the exposure of light on other components such as wiring, plastic parts etc. For shielding of electrical wiring in the rooftop unit, black convoluted tubing is provided in the unit. However, if there is any concern, aluminum foil tape can be used to cover up any exposed component.

⚠ WARNING

Potential Risk of Fire.

Dust, lint and other debris may cause fire if allowed to come in contact with illuminated UVC lamp.

Remove any dust, lint or other debris from lamps and surrounding duct system.

Install Ballast

1- Units With Disconnect Box -

Install the ballast onto the side of the disconnect box; discard ballast bracket. See figure 1. Align holes in ballast with pre-punched mounting holes in the disconnect box. Secure with #10-16X $\frac{5}{8}$ " screws included in the kit.

2- No Disconnect Box -

Install the ballast bracket on the compressor section mullion. See figure 2. Align bracket holes with pre-punched mounting holes on the mullion. Install the ballast on the ballast bracket.

Install Door Switch

Install bracket and switch on front of blower deck as shown in figure 3 and 4.

Route Ballast Cable

Route the ballast cable through the divider panel into the blower section. See figure 4. Wire tie the cable at multiple locations along the refrigerant line.

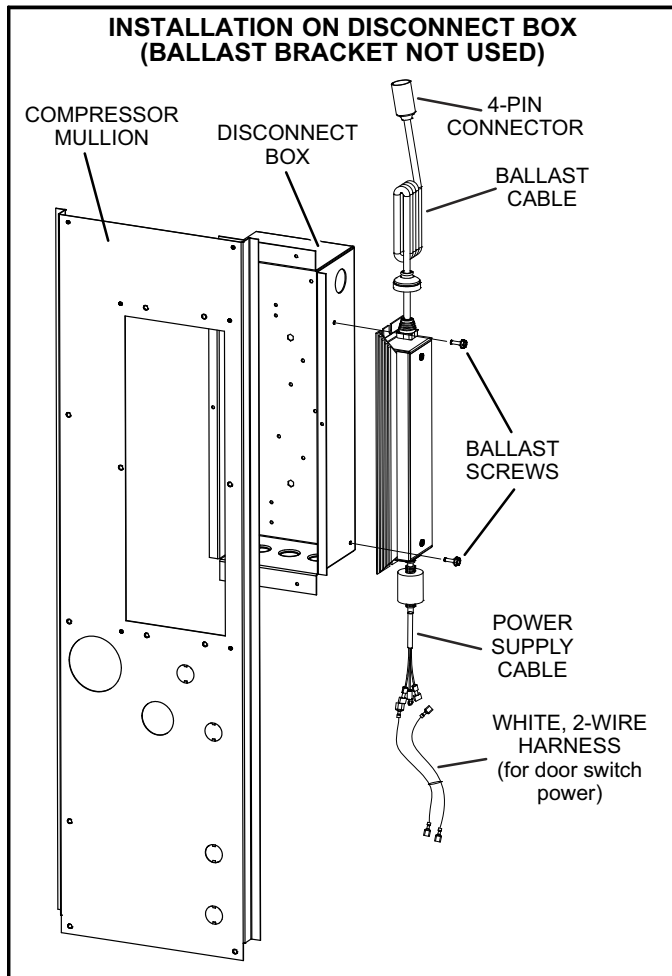

FIGURE 1

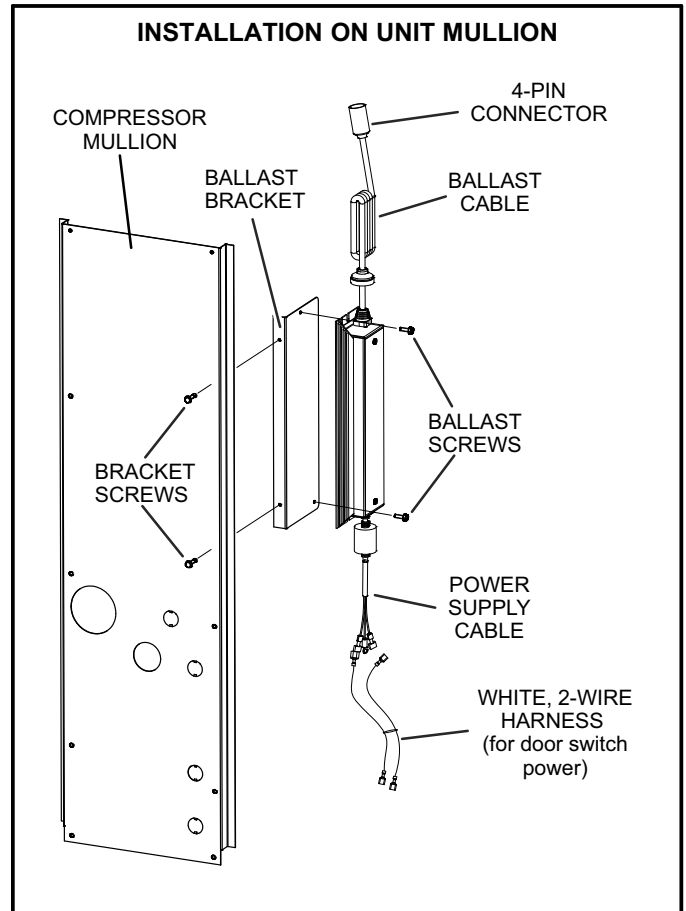

FIGURE 2

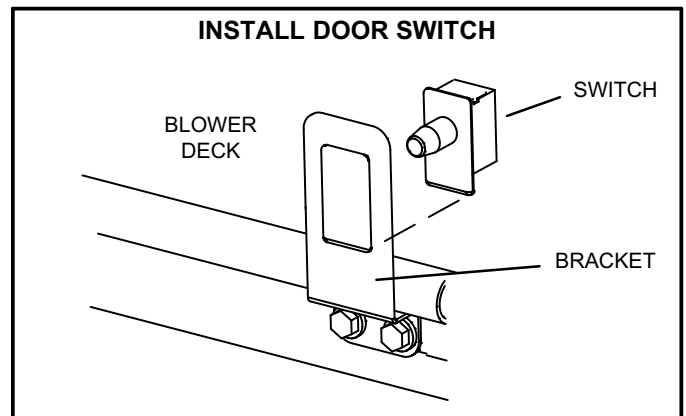

FIGURE 3

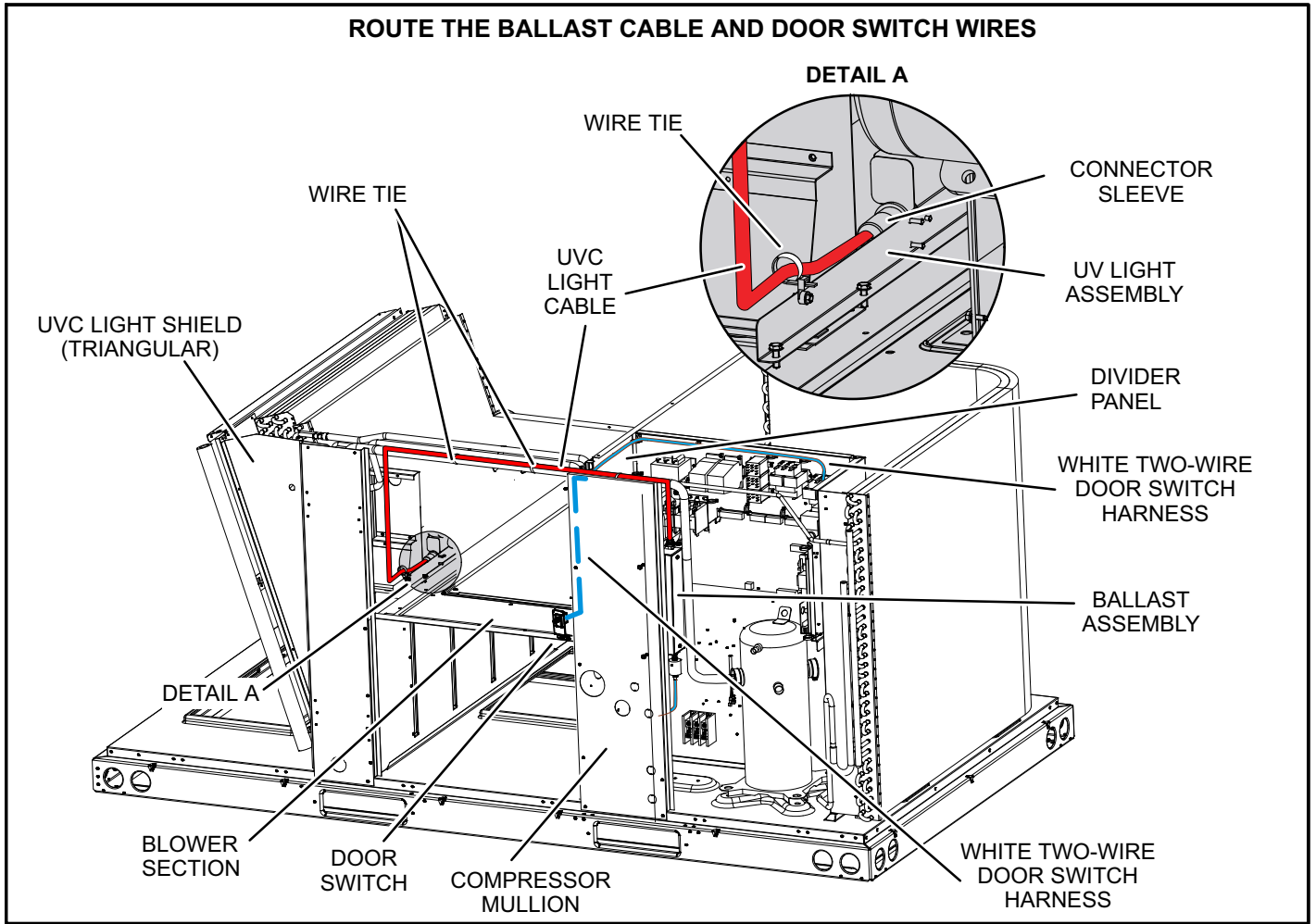

FIGURE 4

Ballast Power Supply Cable

- 1- Route the power supply cable as shown in
 - Figure 5 - 230V LGH/LCH/KG/KC/KH
 - Figure 6 - 460/575V LGH/LCH/KG/KC/KH
 - Figure 10 - 230V LGM/LCM
 - Figure 11 - 460/575V LGM*
 - Figure 12 - 460/575V LCM

- 2- Make wiring connections as shown in:
 - Figure 7 - 230V LGH/LCH/KG/KC/KH
 - Figure 8 - 460/575V LGH/KG with T3
 - Figure 9 - 460/575V LGH/LCH/KG/KC/KH with T49
 - Figure 10 - 230V LGM/LCM
 - Figure 11 - 460/575V LGM*
 - Figure 12 - 460/575V LCM

*Kit harnesses not used.

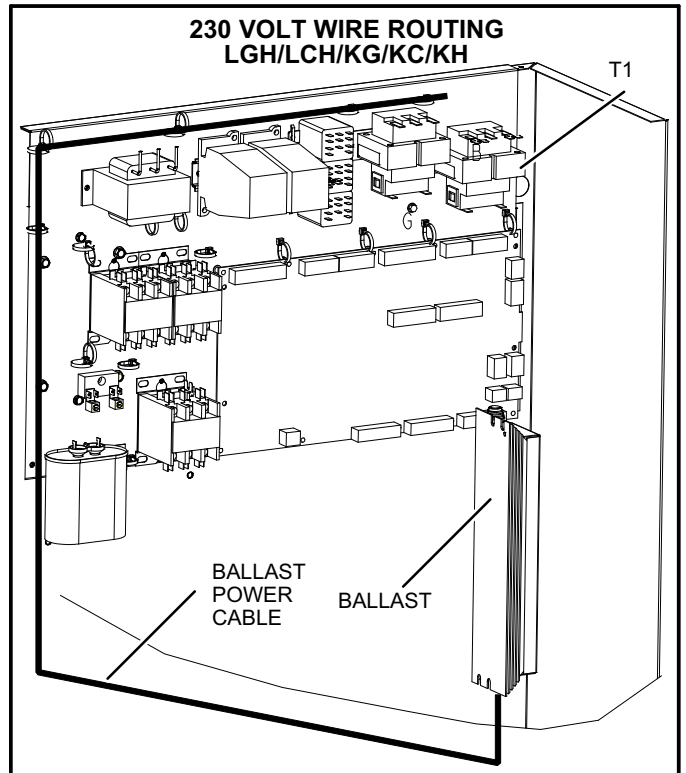

FIGURE 5

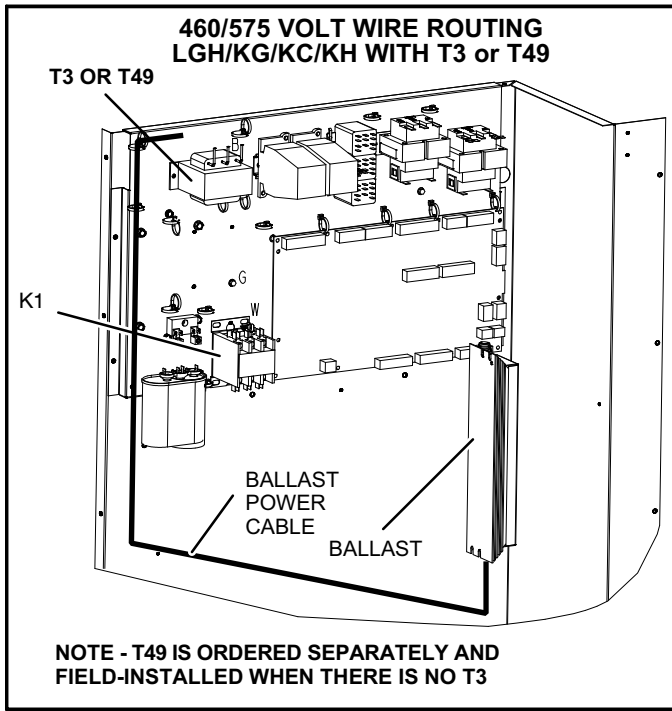

FIGURE 6

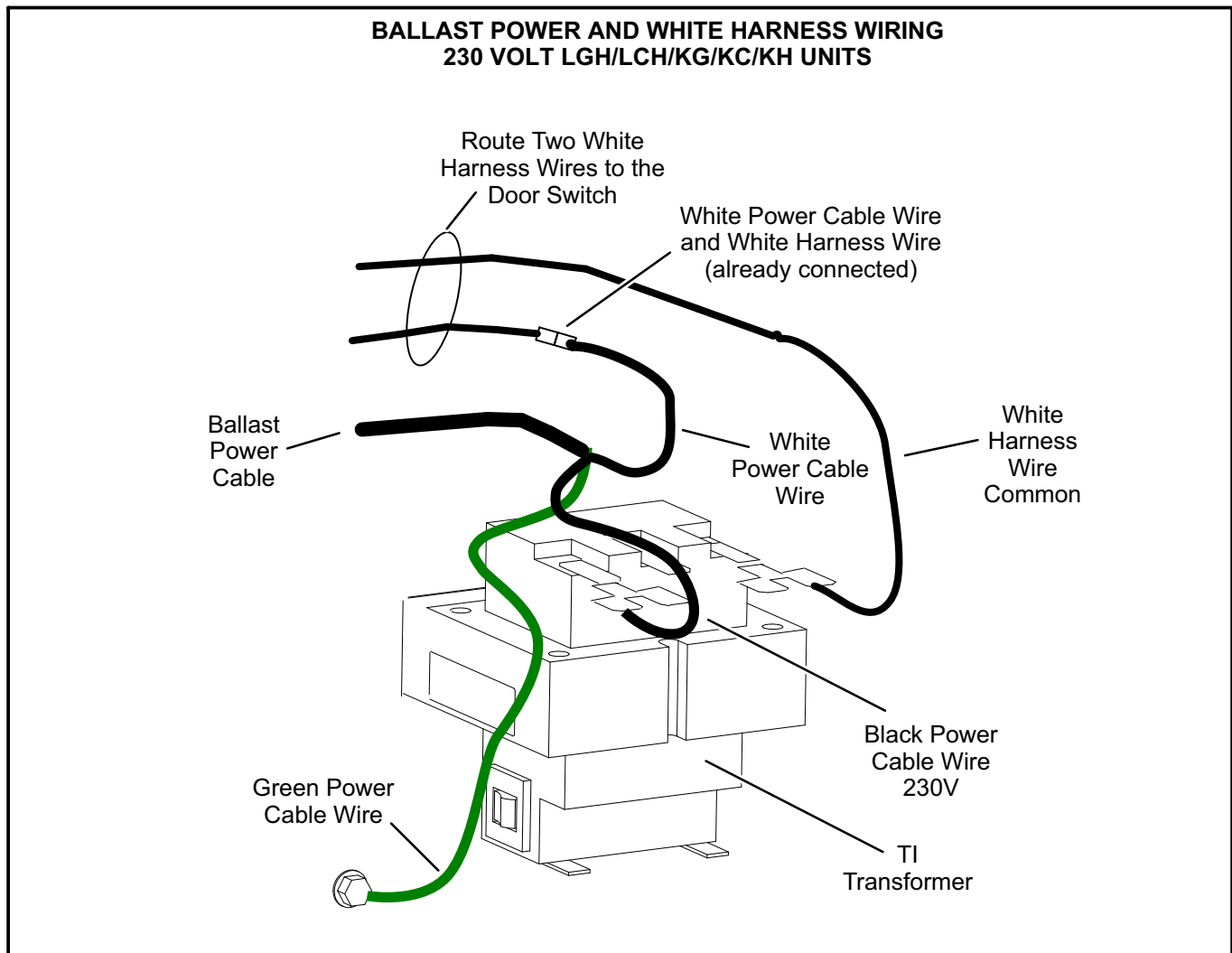

FIGURE 7

**BALLAST POWER AND HARNESS WIRING
460/575 VOLT LGH/KG UNITS
FACTORY-INSTALLED T3**

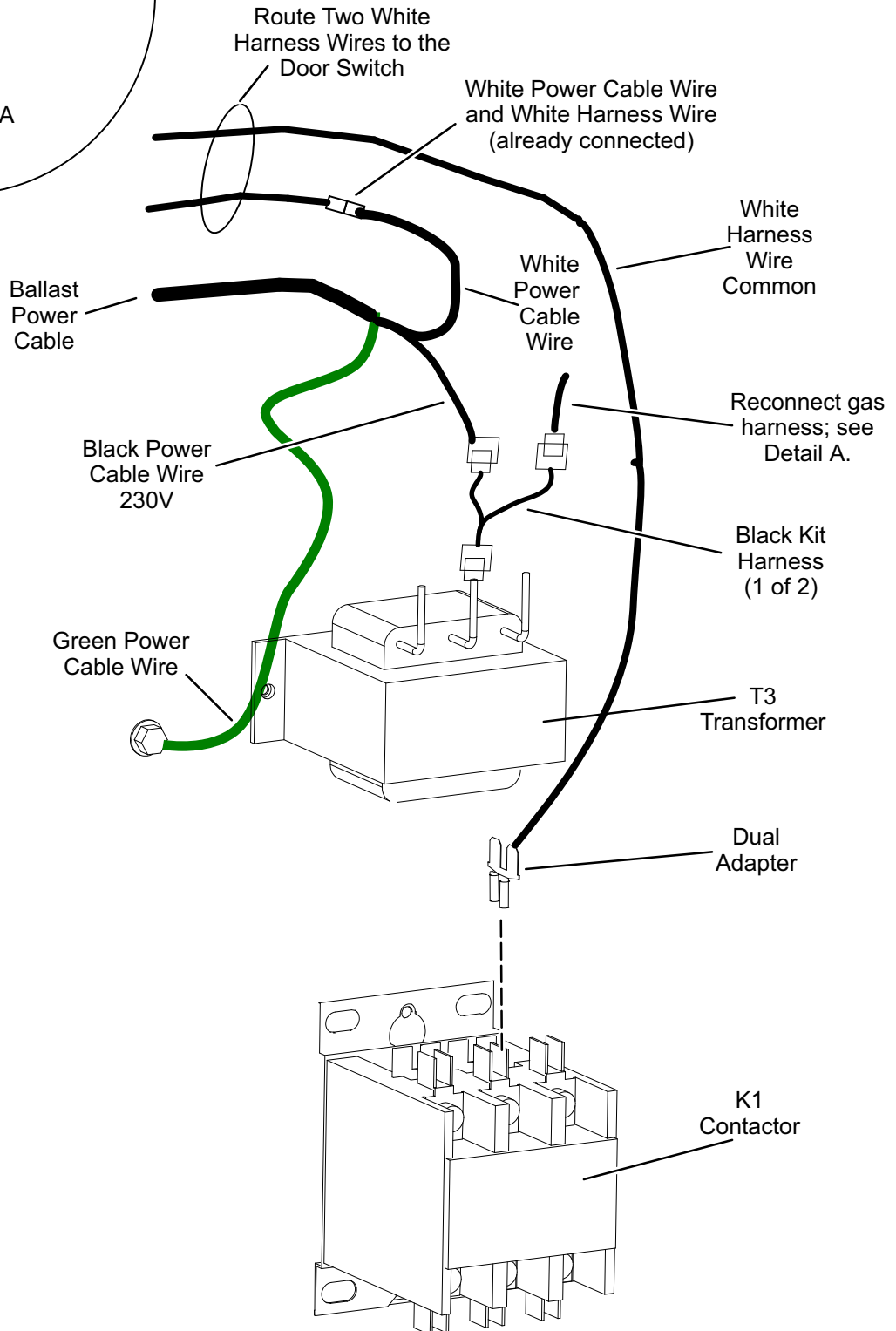
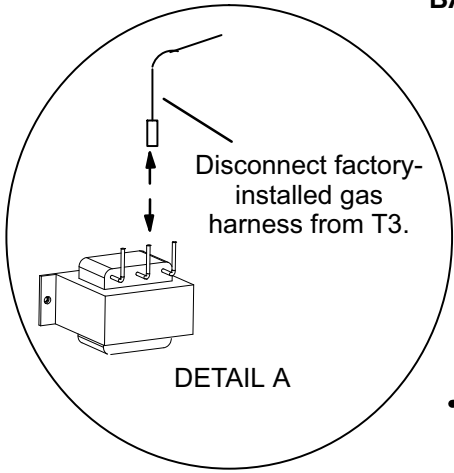

FIGURE 8

**BALLAST POWER AND WHITE HARNESS WIRING
460/575 VOLT LGH/LCH/KG/KC/KH UNITS
WITH SEPARATELY ORDERED AND INSTALLED T49 TRANSFORMER**

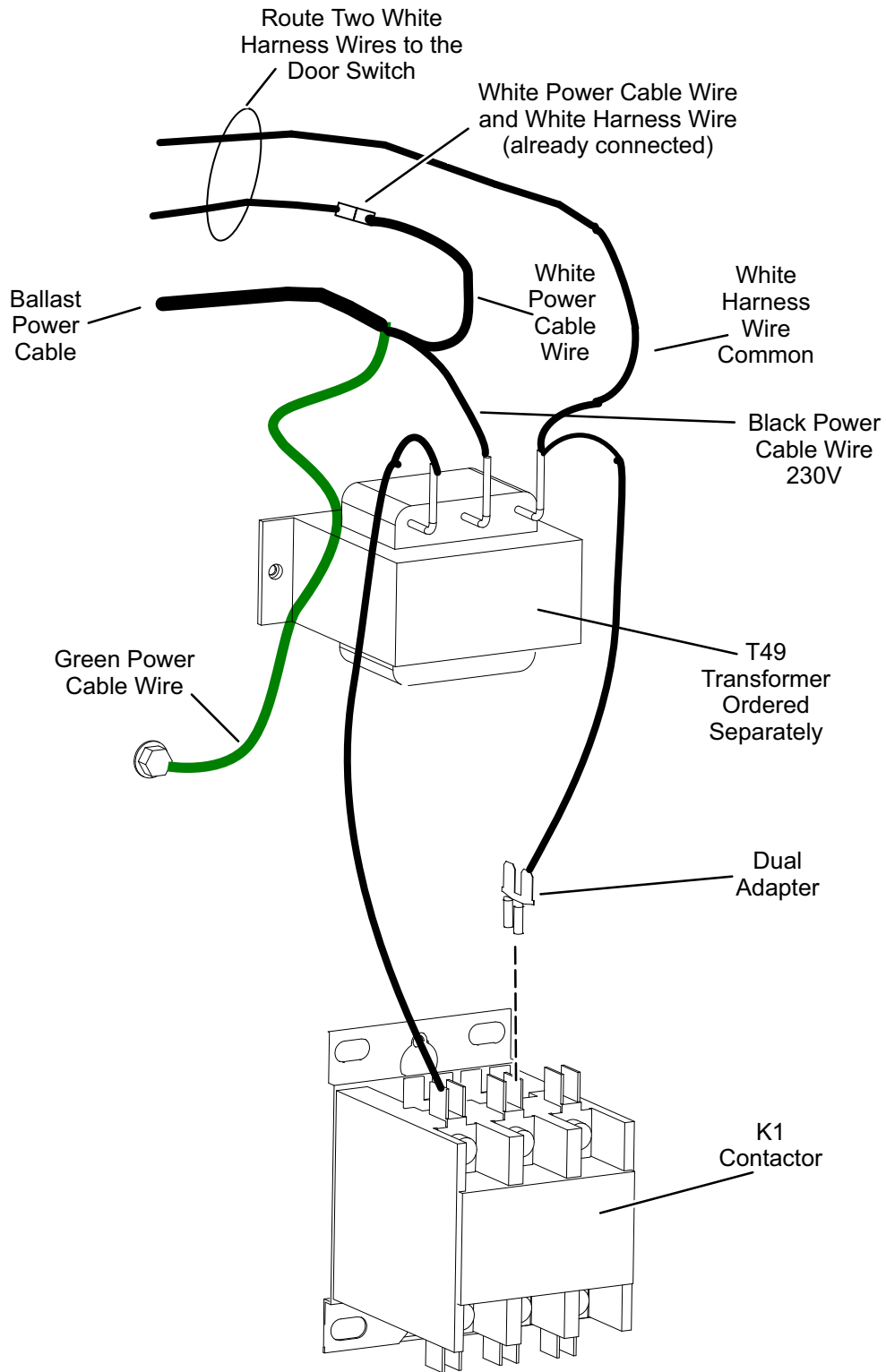
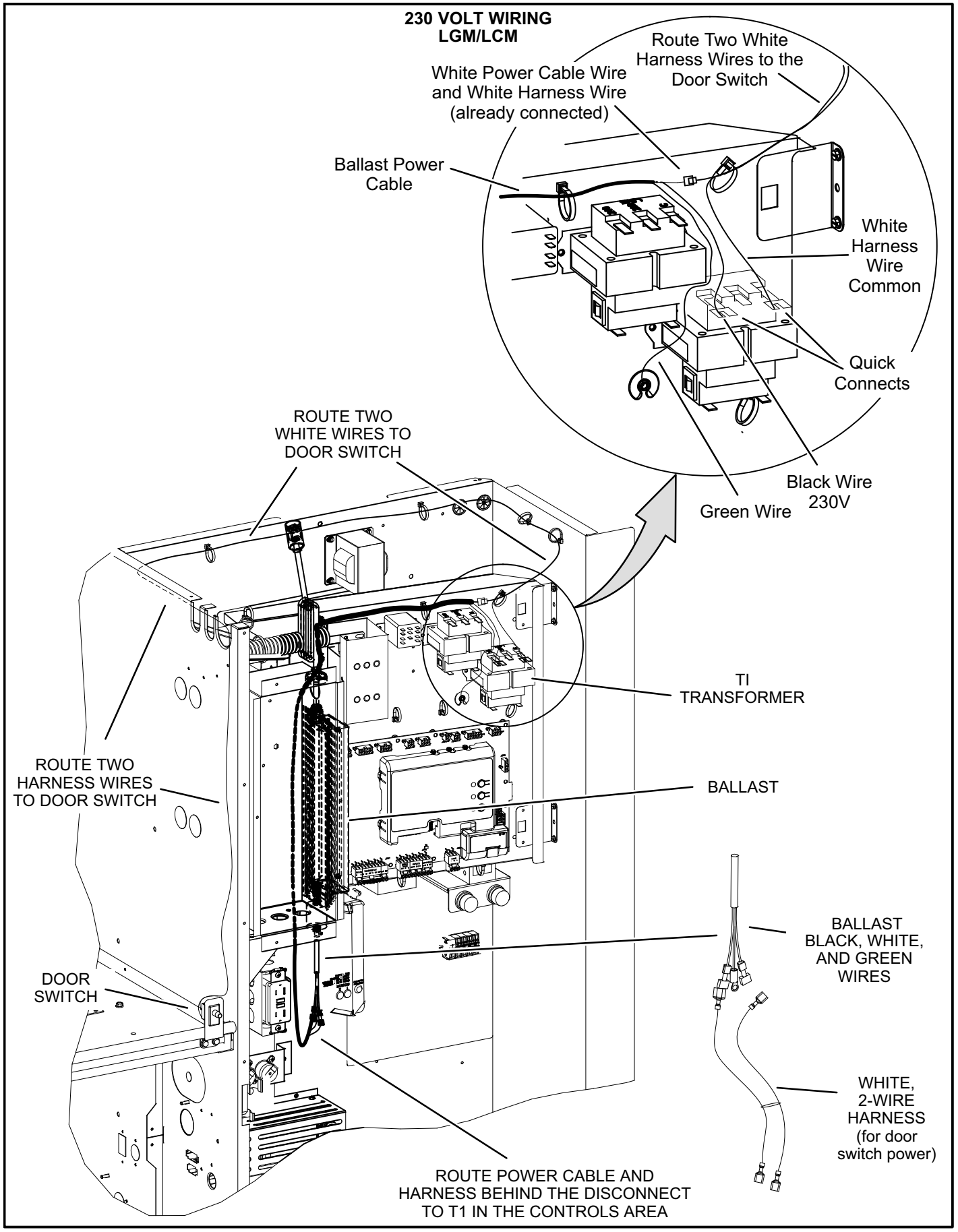

FIGURE 9



**230 VOLT WIRING
LGM/LCM**

White Power Cable Wire
and White Harness Wire
(already connected)

Route Two White
Harness Wires to the
Door Switch

Ballast Power
Cable

White
Harness
Wire
Common

Quick
Connects

ROUTE TWO
WHITE WIRES TO
DOOR SWITCH

Black Wire
230V
Green Wire

T1
TRANSFORMER

BALLAST

ROUTE TWO
HARNESS WIRES
TO DOOR SWITCH

BALLAST
BLACK, WHITE,
AND GREEN
WIRES

DOOR
SWITCH

WHITE,
2-WIRE
HARNESS
(for door
switch power)

ROUTE POWER CABLE AND
HARNESS BEHIND THE DISCONNECT
TO T1 IN THE CONTROLS AREA

FIGURE 10

**460/575 VOLT WIRING WITH T5
LGM**

- 1- Discard kit two-wire jumper harnesses and quick connect adapters.
- 2- A three-wire jumper harness is factory-installed on each of the red wires (230V output) coming from the T5 transformer. One leg powers the Combustion Air Inducer, one leg powers the Outdoor Fan, and the 3rd leg is open for the optional UVC kit. Refer to the pictorial shown here for wiring.
- 3- Connect the power cable wires to the black and white harness wires as shown. Connect the green ground wire.

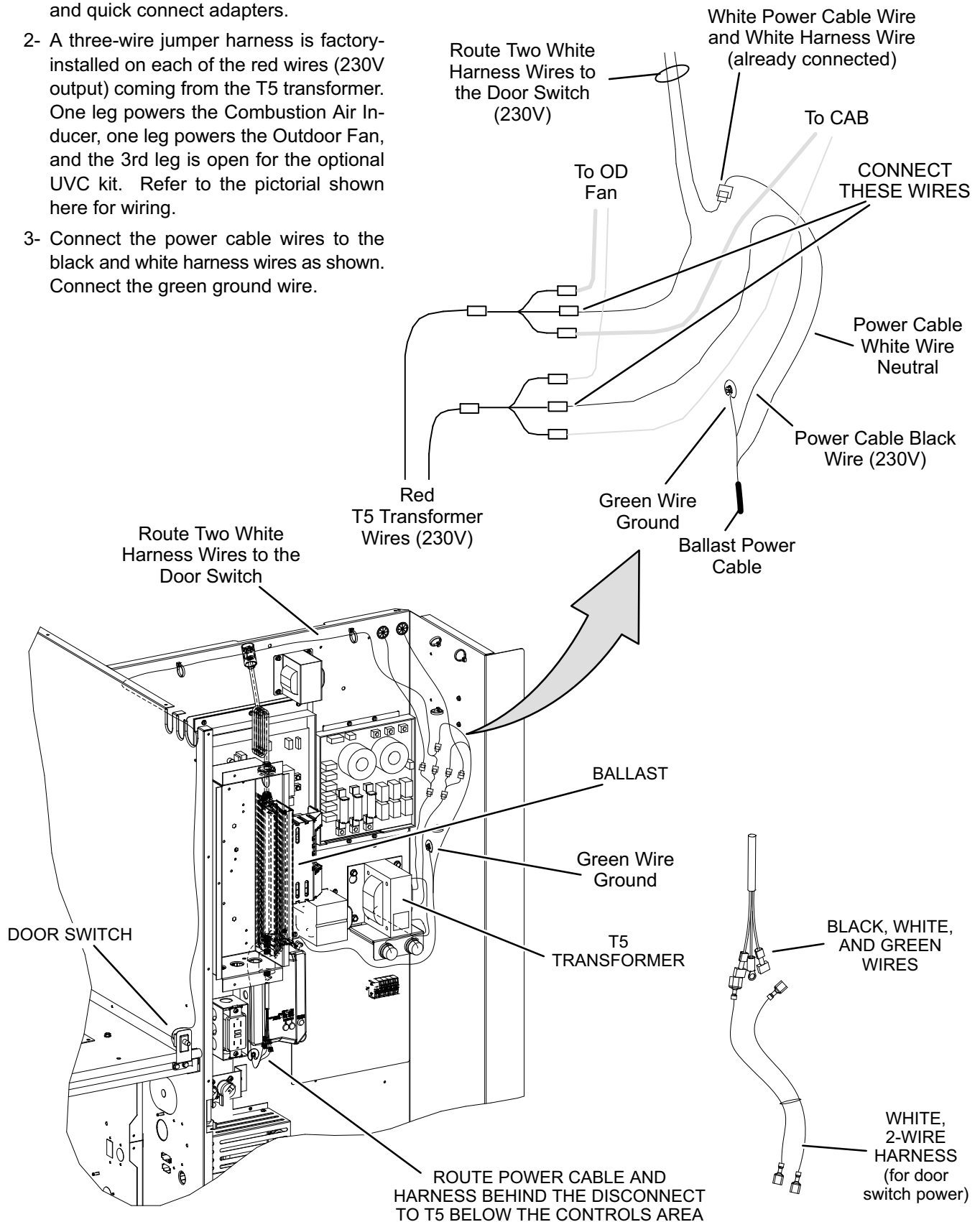

FIGURE 11

**460/575 VOLT WIRING WITH T5
LCM**

- 1- Connect the power cable wires to the black and white harness wires as shown. Connect the green ground wire.
- 2- Disconnect two T5 transformer red wires from outdoor fan wires.
- 3- Install dual quick connect adapters on transformer wires.
- 4- Install the black harnesses, provided in this kit, as shown.

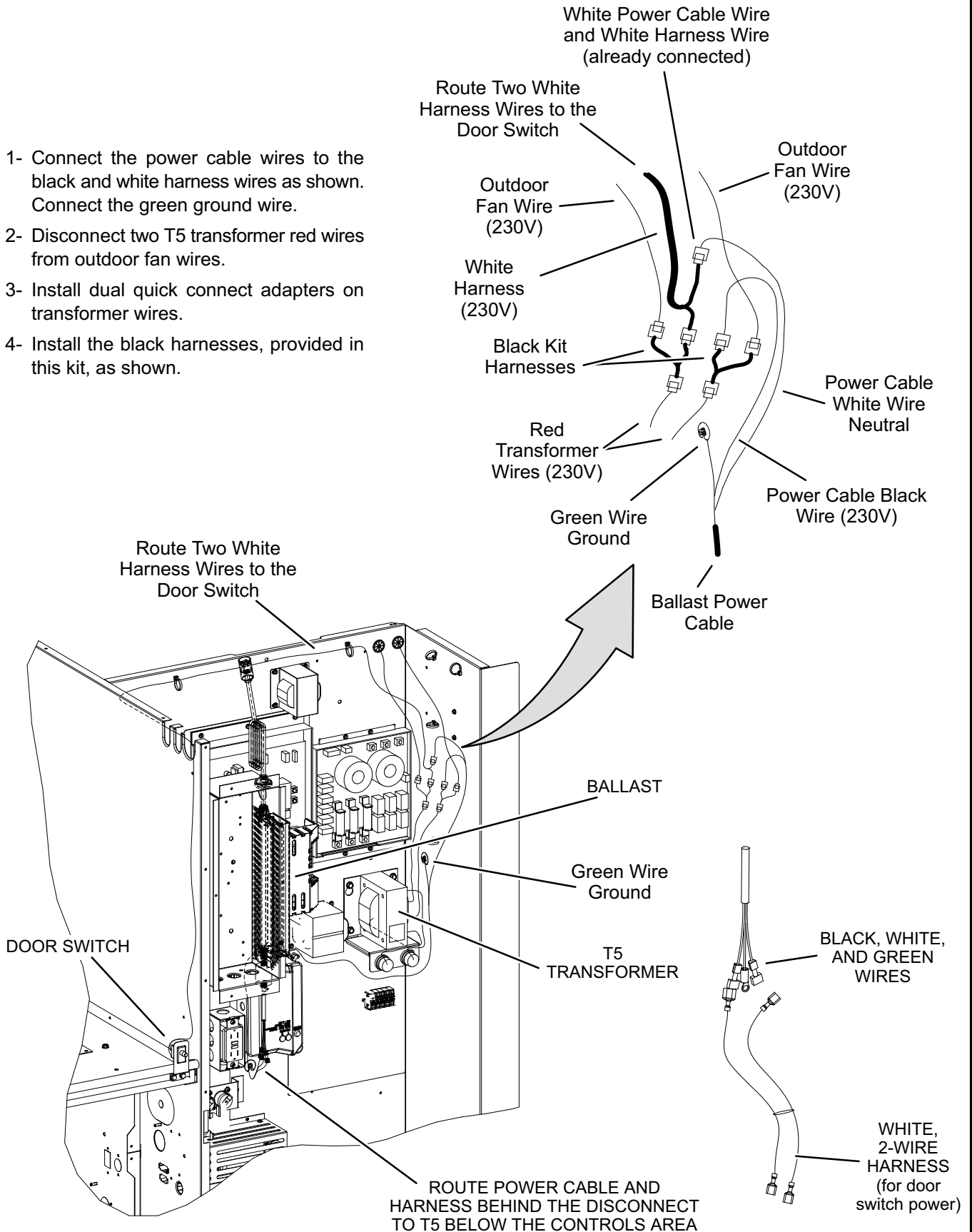

FIGURE 12

Install UVC Light Assembly

The lamp for the UVC light assembly comes separately packaged in a foam sleeve.

- 1- Wear cotton gloves or use a cotton cloth when handling the new lamp. Place the lamp in the holder clips of the UVC sub-assembly (see figure 13). Verify that the lamp flange at the connector end is positioned between the lamp holder clip and the sheet-metal end stop (see detail A in figure 13).

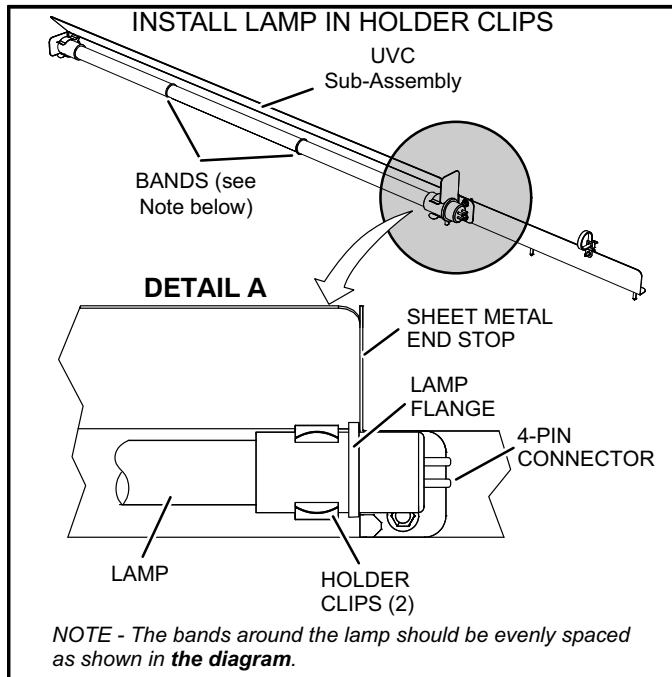

FIGURE 13

- 2- Carefully place the UVC assembly on the blower deck. Line up the mounting holes on the UVC assembly with the mounting holes on the blower deck (see figure 14). Use the #10 screws provided to attach the UVC assembly in place.

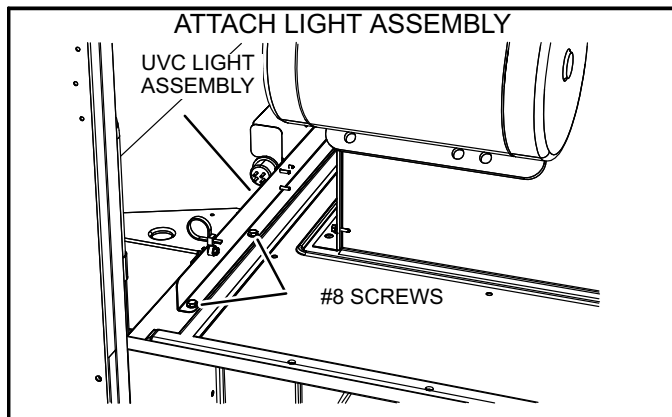

FIGURE 14

Install Lamp Cable

- 1- Run the UVC lamp cable through the open loop of wire tie attached to the UVC assembly (see figure 15).

NOTE:- The cable should not extend past the UVC assembly to be in direct line of sight of UVC lamp.

- 2- Firmly connect the 4-pin connector to the pin end of the lamp. Make sure that the connector sleeve is pushed on the lamp end. Tighten the wire tie loop to strain relief the lamp cable. Trim the wire tie.

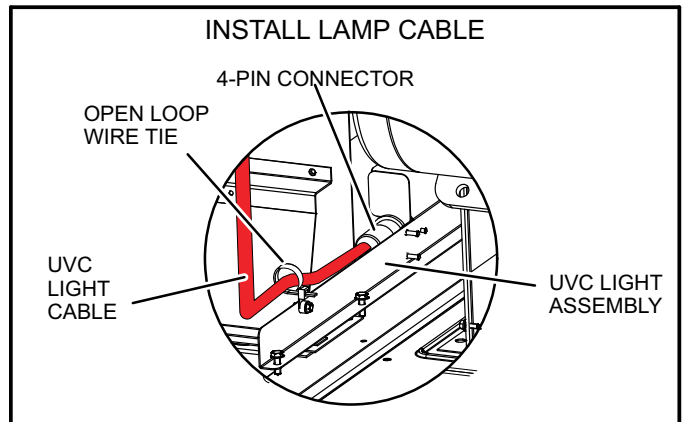

FIGURE 15

Install Convolved Tubing

Install convolved tubing (included in the kit) to shield electrical wiring and components. The tubing is split type making it easy to slip on the wiring. Black wire ties are provided to tie the tubing in place. See figure 16. Not all tubing is used depending on unit options.

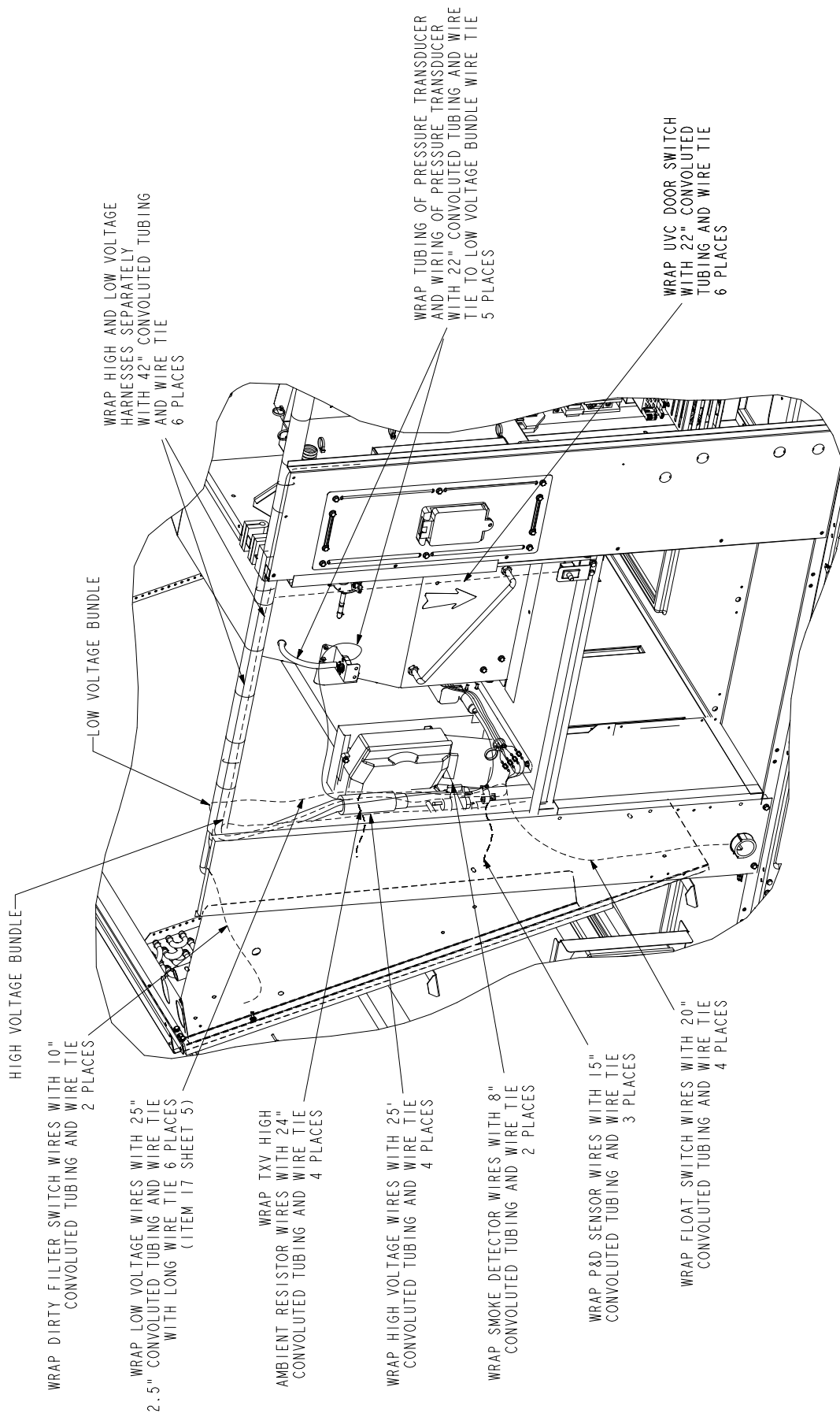

FIGURE 16

Install Triangular UV Shield

To block the UVC light from reaching the filter access door, install the triangular sheet-metal panel (see figure 17).

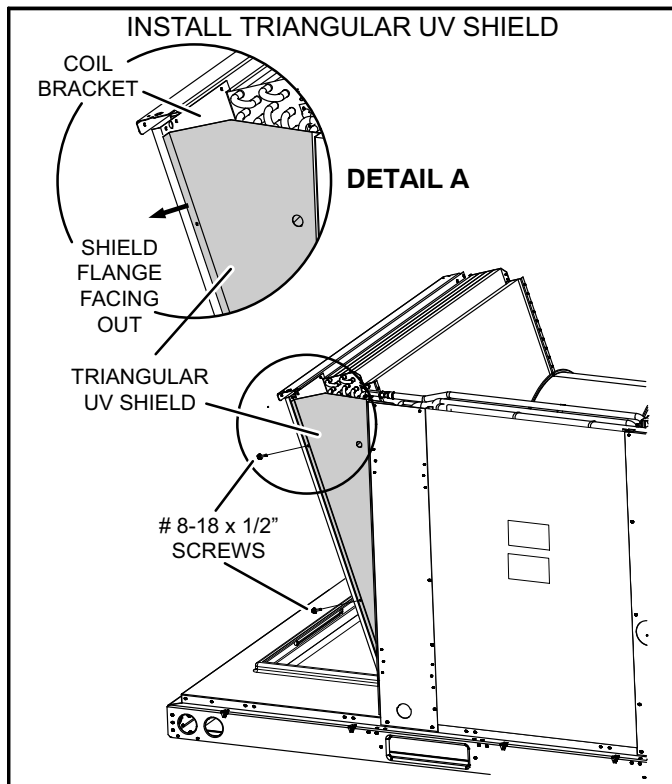

FIGURE 17

With the left flange of the triangular sheet metal panel facing out (see Detail A in figure 17), insert and lower the bottom of the panel through the opening in the filter access door, to the right of the coil and ahead of the refrigerant lines. Slide the panel against the coil bracket and align the holes of the panel with the pre-punched holes on the coil bracket. Use #8-18 x 1/2" screws (included) to attach the panel to the coil bracket. See figure 17.

NOTE - The view port in the triangular panel provides a visual verification when the UVC lamp is turned on. Do not remove the view port as it shields UVC light and protects eyes from UVC exposure.

Finish Installation

Close all access doors before powering UVC lamp. Apply UVC Danger label and UVC Field Kit label to blower access door so that it is clearly visible. See figure 18.

Configure M4 For UVC Light

1- Use the following mobile service app menu to configure the Unit Controller.

SETUP > INSTALL > RTU INFORMATION >
CONFIGURATION ID2

2- Set position 6 to to the appropriate setting to enable the UVC:

2=UV Lamp Only Installed

3=Both UV Lamp and Ionizer Installed

M3 Unit Controller Configuration

Configure the Unit Controller to enable the UVC Lamp using the following menu:

SETUP . INSTALL

Navigate through the various setup questions until **Configuration ID 2** appears. Set position six to the following to enable the UVC feature:

1=UV Lamp only installed

3=BOTH UV Lamp and Ionizer installed.

Operation

For optimal performance, continuous operation of the UVC germicidal lamp is recommended.

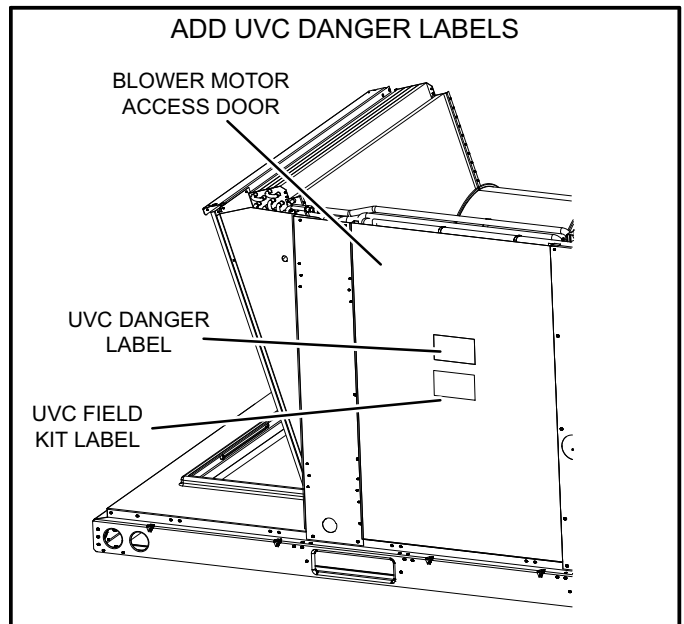

FIGURE 18

Maintenance

⚠ WARNING



Electric shock hazard. Can cause injury or death. Before attempting to perform any service or maintenance, turn the electrical power to unit OFF at disconnect switch(es). Unit may have multiple power supplies.

- For all maintenance, contact a qualified HVAC technician.
- Read the maintenance instructions before opening unit panels.
- Unintended use of the unit or damage to the unit housing may result in the escape of dangerous UVC radiation. UVC radiation may, even in small doses, cause harm to the eyes and skin.
- Do not operate units that are obviously damaged.
- Do not discard the triangular UVC light shield or any barriers with an ultraviolet radiation symbol.
- Do not override the door interlock switch that interrupts power to the UVC light.
- Do not operate the UVC light outside of the unit.

LED(s) not illuminated

Power status LED not lit—Check that the lamp unit is connected to the proper power source and is wired correctly.

Lamp status LED(s) not lit—

- 1- Check that lamp 4-pin connectors are properly engaged.
- 2- Ohm-check across the lamp pins to check for continuity of lamp filaments (see figure 20).

Troubleshooting charts are provided to aid in determining the cause of any problems encountered (figures 19 and 20).

Annual Lamp Replacement

⚠ WARNING

Personal Burn Hazard.

Personal injury may result from hot lamps. During replacement, allow lamp to cool for 10 minutes before removing lamp from fixture.

The lamp should be replaced every 12 months, as UVC energy production diminishes over time.

- 1- Obtain the correct replacement lamp for your germicidal light model.
- 2- Disconnect power to the rooftop unit before servicing the UVC kit.
- 3- Open the blower access door.
- 4- Remove the screw in wire tie from the UVC assembly and disconnect the 4-pin connector from the lamp end.
- 5- Remove the (2) mounting screws of the UVC assembly. Carefully slide the complete UVC assembly out through the blower access door.
- 6- Allow 10 minutes before touching the lamps. Then, carefully remove the old lamp from the lamp holder clips.
- 7- Wear cotton gloves or use a cotton cloth when handling the new lamp. Place the new lamp in the holder clips of the UVC assembly. Verify that the lamp flange at the connector end is sandwiched between the lamp holder clip and the sheet-metal end stop (see figure 13).
- 8- Carefully place the UVC assembly on the blower deck. Line up the mounting holes on the UVC assembly with the mounting holes on the blower deck (see figure 14). Use the #10 screws provided to attach the UVC assembly in place.
- 9- Close the blower access door.
- 10- Reconnect power to the rooftop unit.
- 11- Open the filter access door and look through the view port in the triangular sheet-metal panel to verify that the UVC light is on.

Lamp Disposal

Hg-LAMP Contains Mercury.—Manage in accordance with local, state and federal disposal laws. Refer to www.lamprecycle.org or call 1-800-9-LENNOX.

Proper Clean-up Technique in Case of Lamp Breakage

Wear protective gloves, eye wear and mask.

Sweep the broken glass and debris into a plastic bag, seal the bag, and dispose of properly. Contact your local waste management office for proper disposal.

Do not use a vacuum cleaner. Do not incinerate.

⚠ DANGER

Ultraviolet (UVC) Radiation hazard.
Any exposure will cause significant eye damage and may cause skin damage.
DO NOT look into UVC light source.
Access panels must be in place during appliance operation.

UVC LIGHT TROUBLESHOOTING - POWER

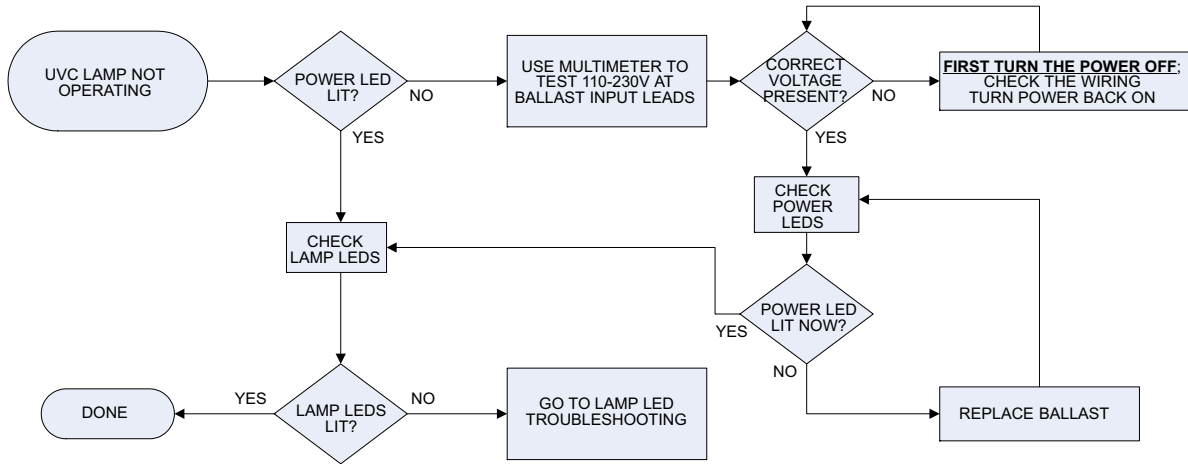

FIGURE 19

UVC LIGHT TROUBLESHOOTING - LAMP

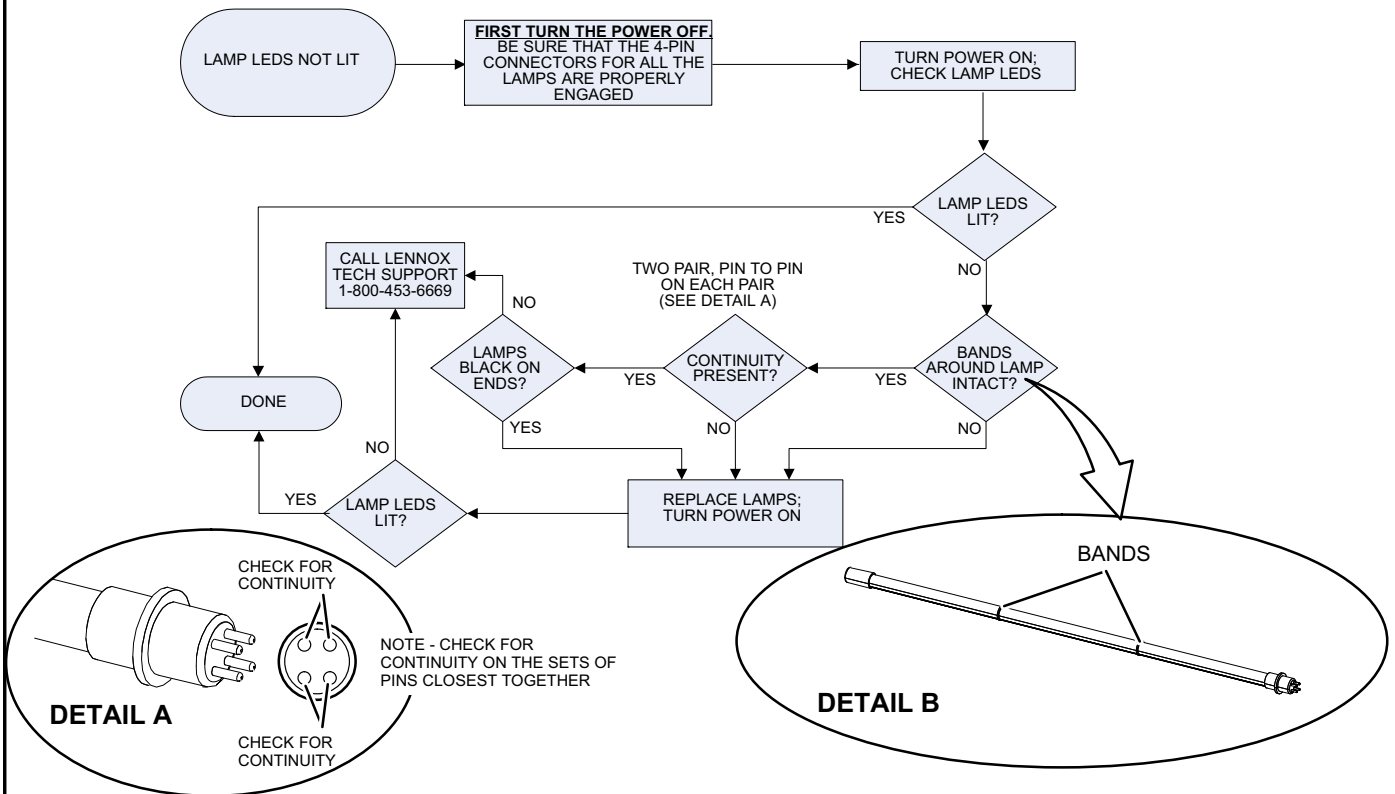

FIGURE 20