



PACKAGED GAS UNITS KITS AND ACCESSORIES

506110-02
5/2022
Supersedes 12/2020

VENT EXTENSION KIT

INSTALLATION INSTRUCTIONS (LB-100525E, LB-115012A & B; 73M72, 31W62, & 42W16) USED ON LG/LD/SG/KG/ZG 024-360 GAS PACKAGED UNITS

Shipping and Packing List

31W62 (LB-115012A) Used on LG/LD/KG/ZG
024-090, ZG 092-150 & SG 036, 060 Units AND
73M72 (LB-100525E) Used on SG 120 Units

Package 1 of 1 contains:

- 1- Vent transition
- 1- Drain cap
- 2- Bracket assemblies
- 2- Vent straps
- 18- #10 - 16 X 5/8" SDST screws
- 2- 1/4-20 X 1.5 Screws
- 2- 1/4-20 Nuts
- 2- Split lockwashers
- 1- Gasket
- 1- Label (73M72 only)

The following field-provided, agency-approved parts are required to complete this installation:

- 2- Lengths of 3" diameter B vent pipe (4" on 73M72)
- 1-3" B Vent tee (4" on 73M72)
- 1-3" Vent cap (4" on 73M72)

42W16 (LB-115012B)

Used on LG/LD/KG 092-360 and SG 240 Units

Package 1 of 1 contains:

- 1- Vent transition
- 1- B vent tee (4" X 4" X 3")
- 1- Drain cap
- 2- Bracket assemblies
- 2- Vent straps
- 18- #10 - 16 X 5/8" SDST screws
- 2- 1/4-20 X 1.5 Screws
- 2- 1/4-20 Nuts
- 2- Split lockwashers
- 1- Gasket

The following field-provided, agency-approved parts are required to complete this installation:

- 2- Lengths of 4" diameter B vent pipe
- 1-4" Vent cap

Check packaging for shipping damage. Contact the last carrier immediately if any shipping damage is found.

⚠ WARNING

Improper installation, adjustment, alteration, service or maintenance can cause property damage, personal injury or loss of life. Installation and service must be performed by a licensed professional HVAC installer or equivalent, service agency, or the gas supplier

⚠ CAUTION

As with any mechanical equipment, contact with sharp sheet metal edges can result in personal injury. Take care while handling this equipment and wear gloves and protective clothing.

Application

The Vent Extension Kit is used when unit vent is too close to fresh air intakes per building codes. The vent kit also prevents ice formation on intake louvers.

This kit is approved for installations where the vent pipe extends no further than 3 ft. (.92m) above the top of the unit.

These instructions are intended as a general guide and do not supersede local codes in any way. Authorities having jurisdiction should be consulted before installation.

Installation

IMPORTANT - Vent assembly must be removed to allow access to heat and blower section. Leave this instruction with the unit to ensure proper reinstallation of vent extension.

- 1- Disconnect all power to unit.
- 2- Remove bird screen from vent opening.
- 3- Install vent transition in field-provided B vent tee as shown in figure 1 for SG 120 units. See figure 2 for all other units.
- 4- Assemble the vent strap and bracket as shown in figure 3. Do not tighten screw. On LG/LD/KG/ZG/SG 024-090 units, turn the bracket 180 degrees to allow clearance for the door handle. See figure 4.



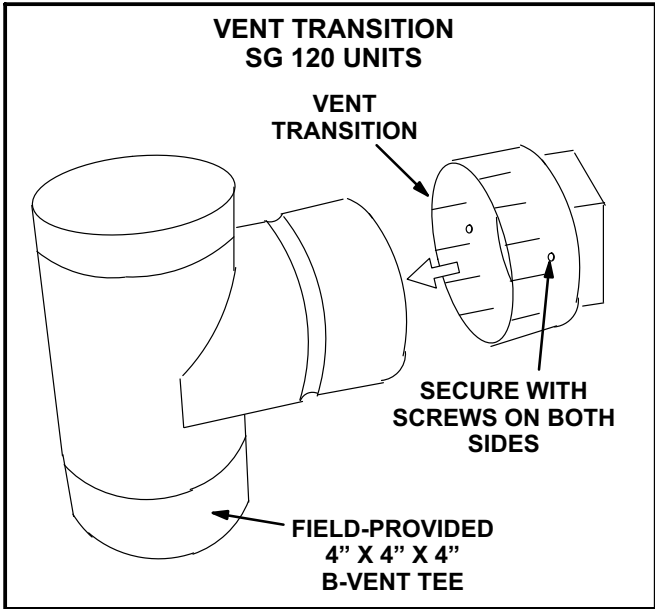

FIGURE 1

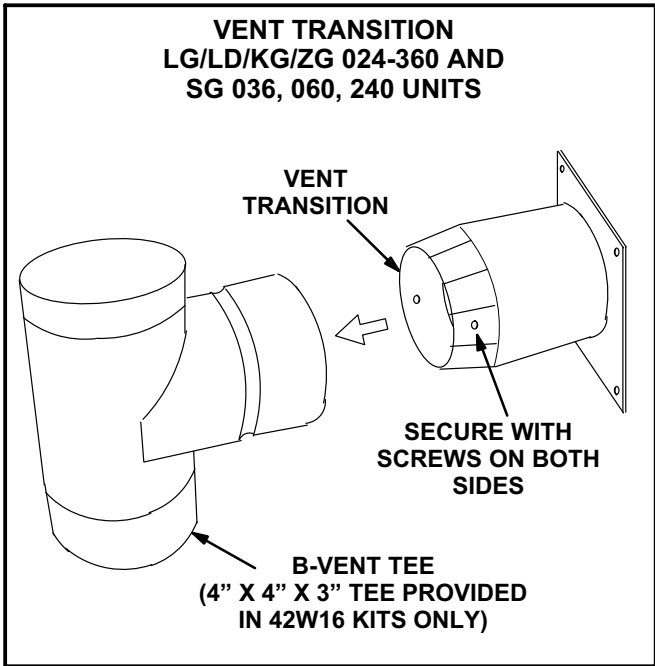

FIGURE 2

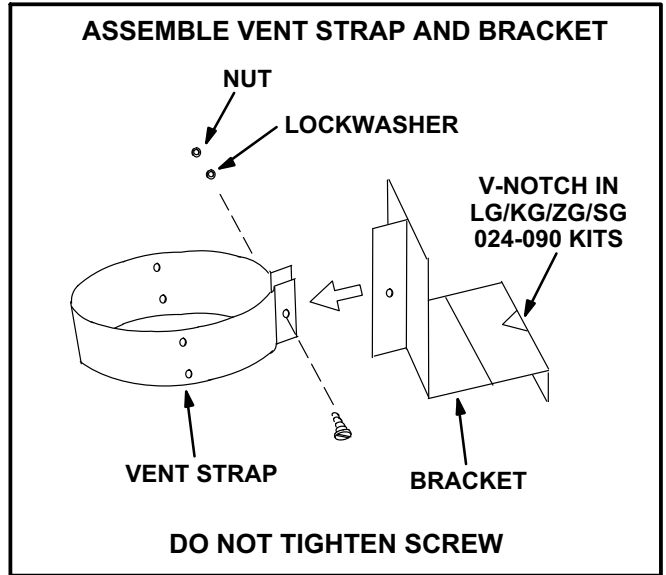

FIGURE 3

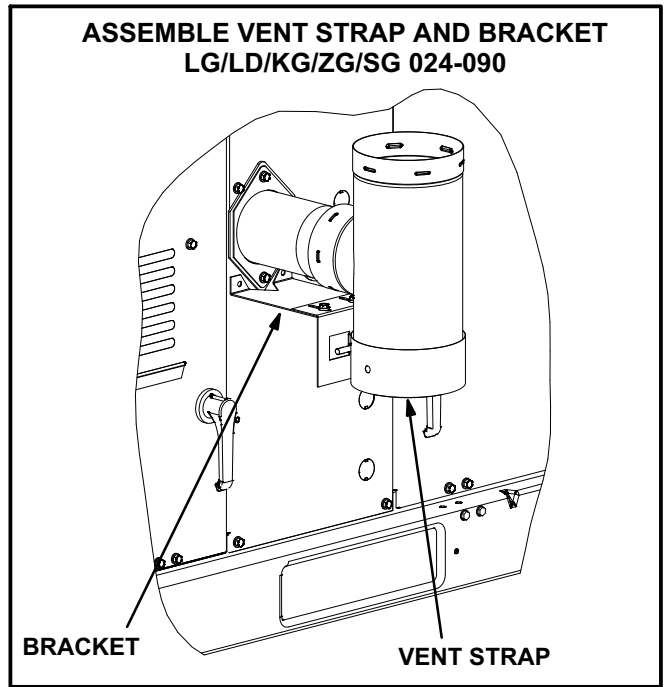

FIGURE 4

5- SG 120 Units -

The opening on the vent transition is offset to avoid overlapping the combustion air intake louvers. The tee must be oriented to ensure proper positioning of the offset. Determine the bottom of the tee using figure 5.

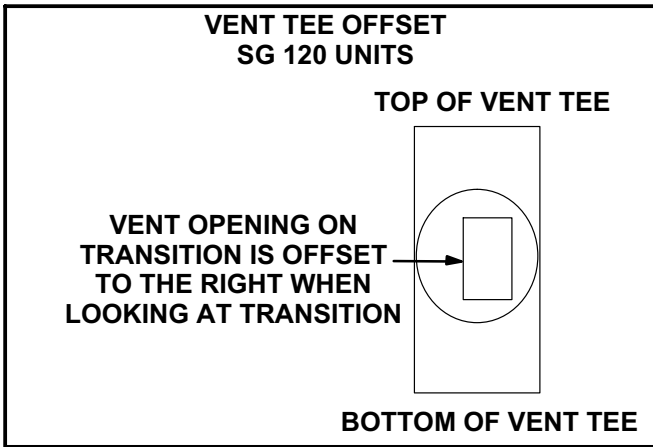

FIGURE 5

- 6- Slide vent strap over bottom of tee and fit the drain cap in the bottom of the tee. See figure 6. Tighten screw in bracket flange. Secure strap and cap with screws on both sides.
- 7- Install vent tee assembly as shown in figures 7 and 8. Make sure the gasket between the transition and the unit forms a good seal to prevent leaks.

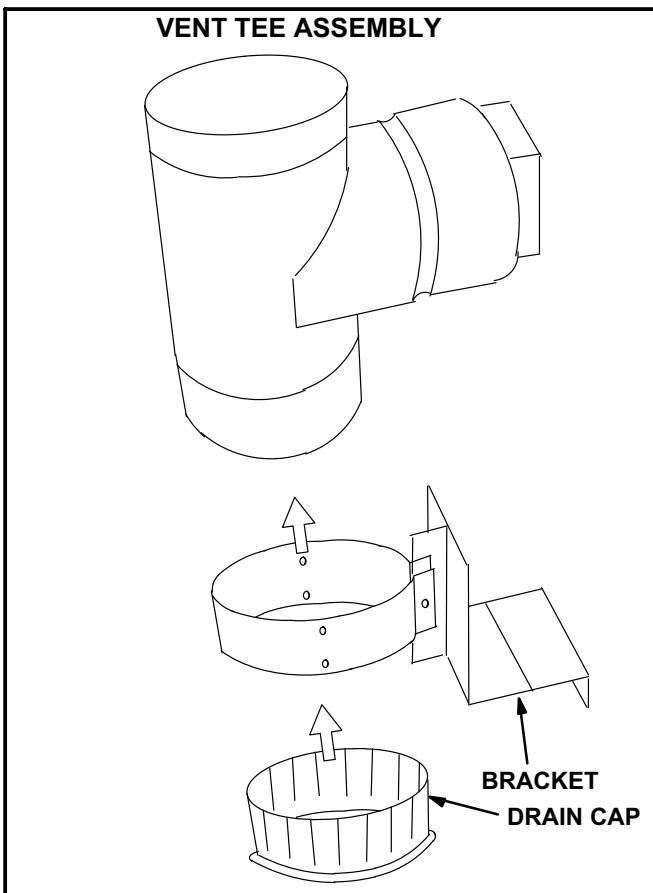

FIGURE 6

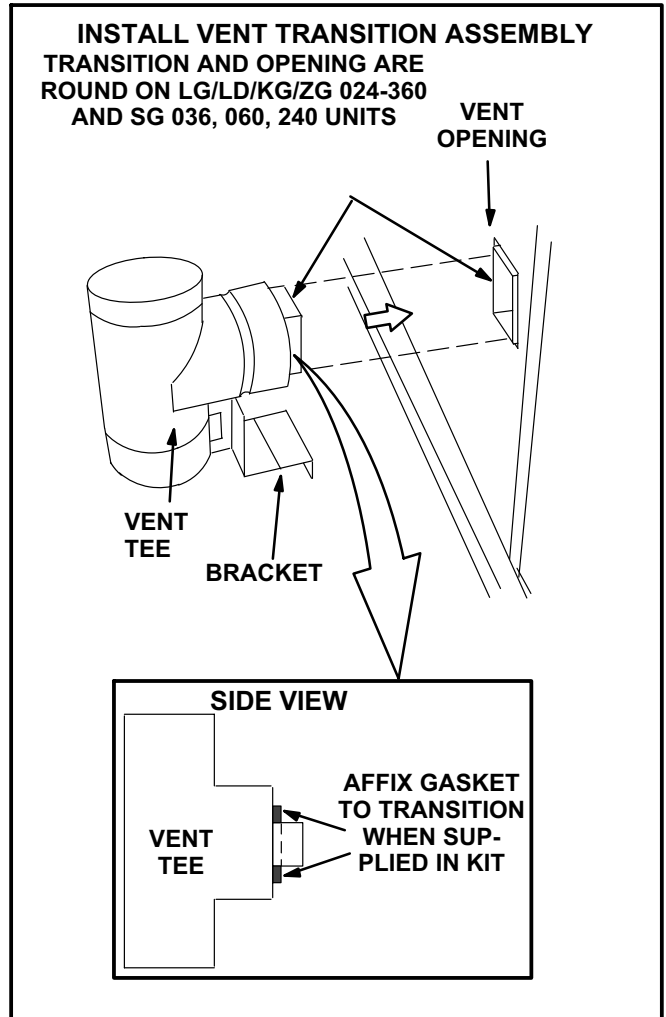

FIGURE 7

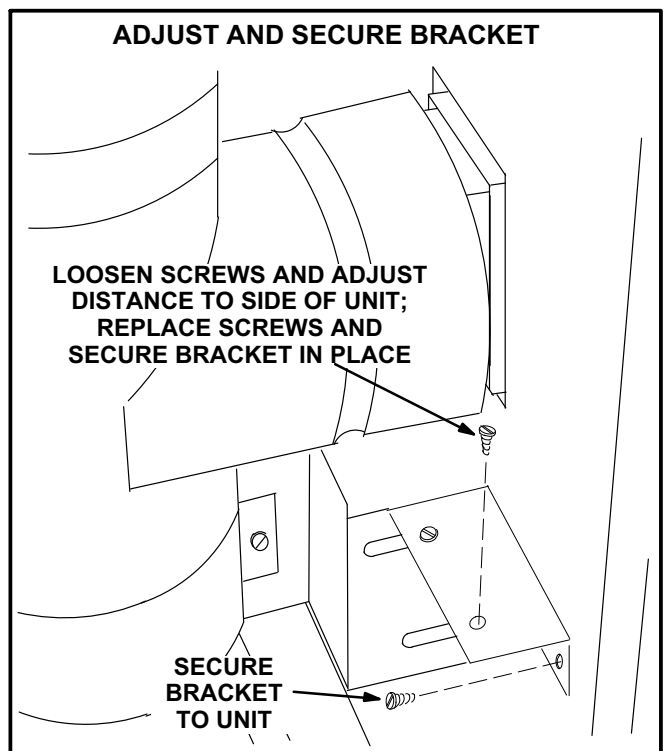

FIGURE 8

- 8- Insert one of two field-provided B vent pipes into tee and secure in place with two sheet metal screws.
- 9- Assemble vent strap and bracket as shown in figure 3 without tightening screw.
- 10- Slide bracket assembly over the top of installed vent pipe. Secure as shown in figure 9. Make sure bracket is as high on the door as possible but beneath unit top flange.

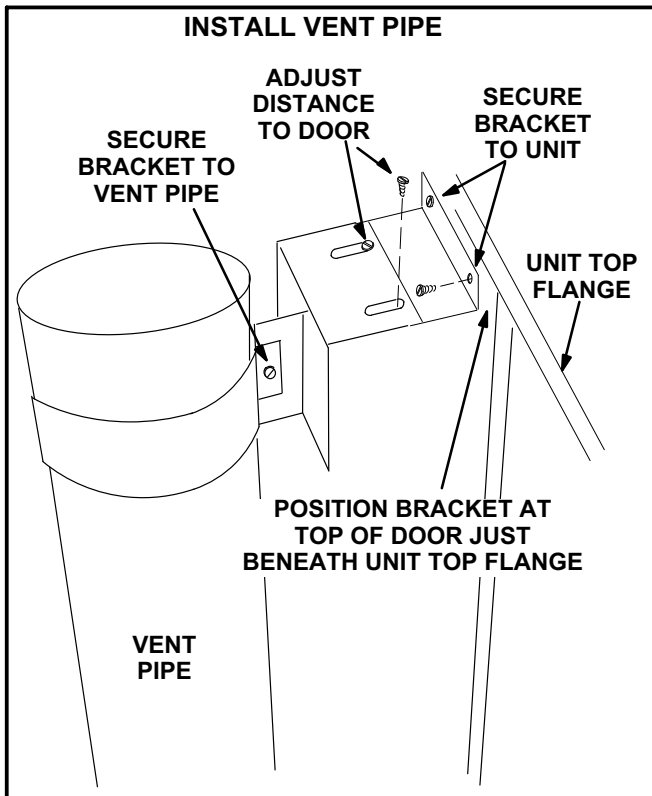

FIGURE 9

- 11- Install field-provided vent cap on the second vent pipe. Secure in place with two screws. Insert the vent pipe into the vent pipe which is already installed on the unit. Secure with two screws. See figure 10.

- 12- SG 120 and ZG 036-150 Units - Affix label near the handle on the heat section access doors. The label instructs that the vent assembly must be removed to allow access to heat and blower sections.

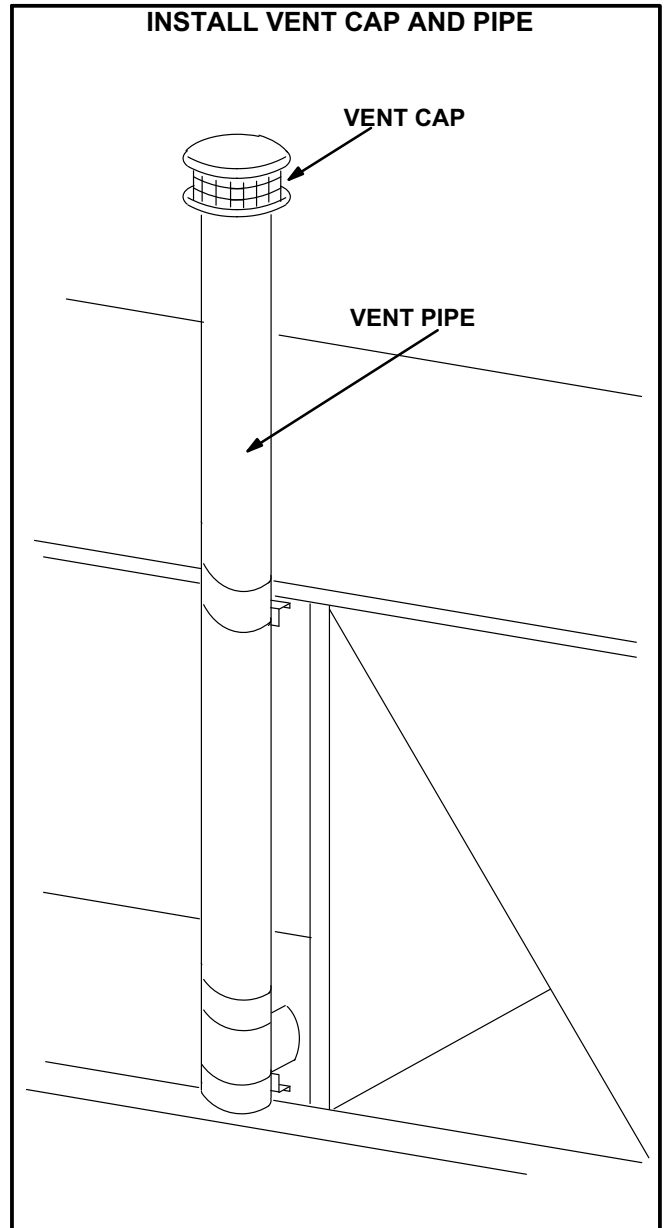

FIGURE 10