

FEATURES

- Over 50 years of unit expertise and design
- Self-contained Heating and Cooling Packaged Unit
 - No need for outdoor units, line sets, or separate venting
 - Pre-wired and pre-charged

REFRIGERANT SYSTEM

- High-efficiency compressor standard on all models
- HWC***-7-11-30P includes a two-stage high-efficiency compressor
- Copper tubing with enhanced aluminum fin coils
- Slide-out Cooling chassis for ease of service
- Anti-microbial evaporative drain pan
- Freeze Shield™ condensate trap on all HWC9 models†

HEAT EXCHANGER

- AFUE ratings up to 95%
- Stainless steel primary heat exchanger on all models
- Stainless steel secondary heat exchanger and transition box on HWC9 models
- Direct vent/sealed combustion

BLOWER

- Multi-speed blower motor for diverse airflow range
- Resilient motor mounts for smooth and quiet operation
- Internal washable filter is standard

CONTROLS

- Conventional 24V thermostat
 - One Stage Cool/Heat required up to 2 tons
 - Two Stage Cool/One Stage Heat for 2.5-ton model
- Color-coded wiring for ease of installation and service
- Diagnostic LED
- Easily accessible control box
- Optional field installed refrigerant detection system

WARRANTY

- Five (5) Year Limited Parts Warranty
- Twenty (20) Year Limited Stainless-Steel Heat Exchanger Warranty

HWC MODEL UNITS GAS HEATING / ELECTRIC COOLING PACKAGED UNITS



† Patent Pending

NOTE: HWC8 not for sale in Canada

MODEL NUMBER GUIDE

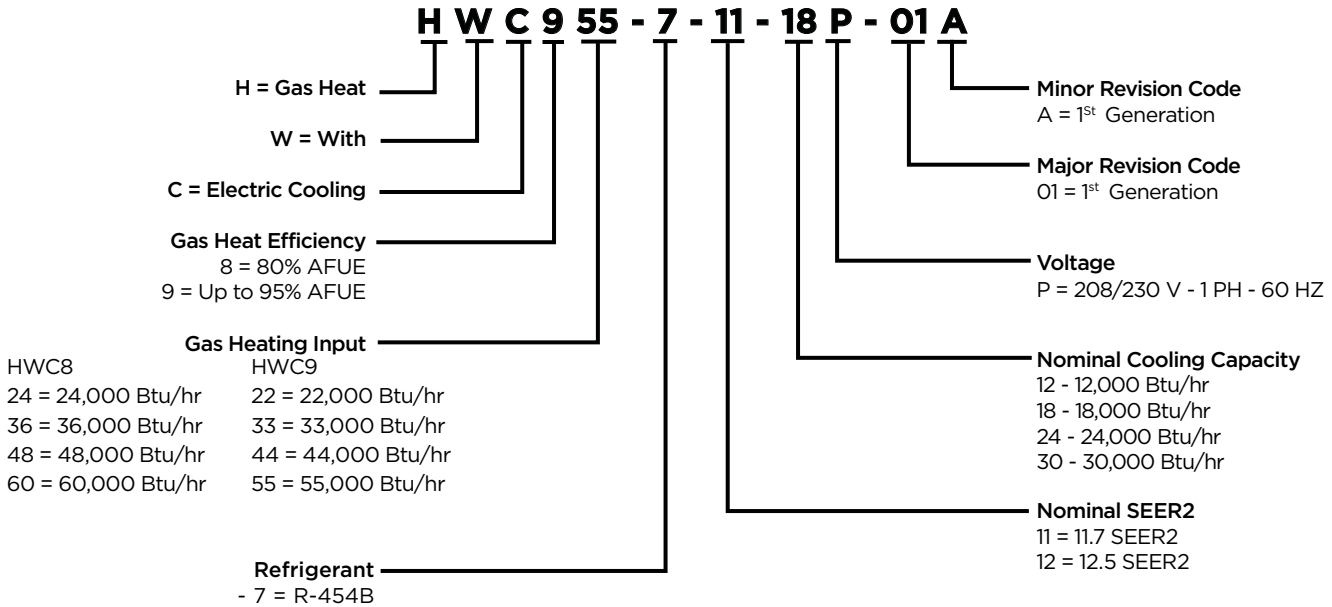

ELECTRICAL AND PHYSICAL DATA

Model	Voltage/Hz/ Phase	Voltage Range	Min. Circuit Amps	Max. Fuse/ HACR Brkr.	Compressor		Outside Fan				Indoor Blower			R454B Charge	Approx. Weight (lbs.)					
					Rated Load Amps	Locked Rotor Amps	Dia	Nominal RPM	Full Load Amps	HP	Wheel Dia. x Width	Full Load Amps	HP							
HWC824-7-11-12P-01A	208-230/60/1	197-253	9.6	15	4.9	27.0	18.0	1075	0.9	1/8	10 x 4.375	4.1	1/2	36	284					
HWC836-7-11-12P-01A			9.6	15																
HWC824-7-12-12P-01A			9.3	15																
HWC836-7-12-12P-01A			9.3	15																
HWC836-7-11-18P-01A			12.0	15	6.3	37.5		1075	1.4	1/4		4.1		53						
HWC848-7-11-18P-01A			12.0	15																
HWC860-7-11-18P-01A			12.0	15																
HWC836-7-12-18P-01A			12.2	15																
HWC848-7-12-18P-01A			12.2	15	12.7	61.6		1100	2.8	1/3		3.7		57						
HWC860-7-12-18P-01A			12.2	15																
HWC836-7-11-24P-01A			19.6	25																
HWC848-7-11-24P-01A			19.6	25																
HWC860-7-11-24P-01A			19.6	25	16.2	78.1		1200	2.8	1/3		4.1		50						
HWC848-7-11-30P-01A			24.0	30																
HWC860-7-11-30P-01A			24.0	30																
HWC836-7-11-24P-01A			19.6	25												208-230/60/1	197-253	18.0	1075	0.9
HWC933-7-11-12P-01A	9.6	15																		
HWC922-7-12-12P-01A	9.3	15																		
HWC933-7-12-12P-01A	9.3	15																		
HWC933-7-11-18P-01A	12.0	15	6.3	37.5	1075	1.4	1/4	4.1	53											
HWC944-7-11-18P-01A	12.0	15																		
HWC955-7-11-18P-01A	12.0	15																		
HWC933-7-12-18P-01A	12.2	15																		
HWC944-7-12-18P-01A	12.2	15	12.7	61.6	1100	2.8	1/3	3.7	57											
HWC955-7-12-18P-01A	12.2	15																		
HWC933-7-11-24P-01A	19.6	25																		
HWC944-7-11-24P-01A	19.6	25																		
HWC955-7-11-24P-01A	19.6	25	16.2	78.1	1200	2.8	1/3	4.1	50											
HWC944-7-11-30P-01A	24.0	30																		
HWC955-7-11-30P-01A	24.0	30																		
HWC933-7-11-24P-01A	19.6	25																		

PERFORMANCE

Model	Cooling			Heating			
	Btuh	SEER2	S/T	Input Btuh	Output Btuh	AFUE	Temp. Rise Range °F
HWC824-7-11-12P-01A	12,000	11.7	0.75	24,000	19,000	80	25-55
HWC836-7-11-12P-01A				36,000	28,500		35-65
HWC824-7-12-12P-01A		12.5	0.75	24,000	19,000		25-55
HWC836-7-11-12P-01A				36,000	28,500		35-65
HWC836-7-11-18P-01A	17,000	11.7	0.78	36,000	28,500		25-55
HWC848-7-11-18P-01A				48,000	38,000		35-65
HWC860-7-11-18P-01A				60,000	47,500		45-75
HWC836-7-12-18P-01A	16,800	12.4	0.77	36,000	28,500		25-55
HWC848-7-12-18P-01A				48,000	38,000		35-65
HWC860-7-12-18P-01A				60,000	47,500		45-75
HWC836-7-11-24P-01A	22,200	11.7	0.73	36,000	28,500		25-55
HWC848-7-11-24P-01A				48,000	38,000		35-65
HWC860-7-11-24P-01A				60,000	47,500	45-75	
HWC848-7-11-30P-01A	26,800	11.7	0.73	48,000	38,000	30-60	
HWC860-7-11-30P-01A				60,000	47,500	45-75	
HWC922-7-11-12P-01A	12,000	11.7	0.75	22,000	20,500	95	25-55
HWC933-7-11-12P-01A				33,000	31,000		35-65
HWC922-7-12-12P-01A		12.5		22,000	20,500		25-55
HWC933-7-12-12P-01A				33,000	31,000		35-65
HWC933-7-11-18P-01A	17,000	11.7	0.78	33,000	31,000	95	30-60
HWC944-7-11-18P-01A				44,000	41,000	95	35-65
HWC955-7-11-18P-01A				55,000	51,500	93	45-75
HWC933-7-12-18P-01A	16,800	12.4	0.77	33,000	31,000	95	30-60
HWC944-7-12-18P-01A				44,000	41,000	95	35-65
HWC955-7-12-18P-01A				55,000	51,500	93	45-75
HWC933-7-11-24P-01A	22,200	11.7	0.73	33,000	31,000	95	30-60
HWC944-7-11-24P-01A				44,000	41,000	95	35-65
HWC955-7-11-24P-01A				55,000	51,500	93	45-75
HWC944-7-11-30P-01A	26,800	11.7	0.73	44,000	41,000	95	35-65
HWC955-7-11-30P-01A				55,000	51,500	93	45-75

NOTE: For most up to date ratings and values, please view AHRI listing

FACTORY FILTER SIZE (IN.) AND PRESSURE DROP (IN. W.C.)

Model	Filter Size	Supply Airflow (CFM)							
		300	400	500	600	700	800	900	1000
All HWC	16.5 x 25	0.01	0.01	0.02	0.03	0.03	0.04	0.05	0.06

Performance based on factory-provided washable filter installed in the unit. If a higher resistance filter is installed in the unit, the added resistance must be included in the external static pressure and must not exceed 0.4 in. w.c. including ductwork.

ACCESSORIES

Description	Kit #	Where Used
LP KIT (0 - 4,500 FT)	ALPKT842	HWC8 Only
High Altitude Kit (NAT 4,500 - 8,000 ft.)	AHAKT01	
Decorative External Louver Clear Anodized Aluminum	ALVR42	
Decorative External Louver Painted Aluminum	ALVR42P	
LP KIT (0 - 4,500 FT)	ALPKT843	HWC9 Only
High Altitude Kit (NAT 4,500 - 8,000 ft.)	AHAKT02	
Decorative External Louver Clear Anodized Aluminum	ALVR43	
Decorative External Louver Painted Aluminum	ALVR43P	
Wall Sleeve	CA239	All HWCs
Refrigerant Detection System (RDS) MagicPak V-Series Kit	ARDSKTV	All HWCs

HWC9 COMBUSTION INDUCER ORIFICE

Model	Orifice Color
HWC9N22	Blue
HWC9N33	Black
HWC9N44	Gray
HWC9N55	Brown

FURNACE CONDENSATE PER HOUR OF CONTINUOUS HEATING OPERATION*

Model	Gal./Hr.
HWC9N22	0.15
HWC9N33	0.20
HWC9N44	0.25
HWC9N55	0.30

* Approximate at 65°F and 80% RH

COOLING PERFORMANCE EXTENDED RATINGS

Model	Indoor Temp DB/ WB °F	Outdoor Temperature - DB °F (0.3" w.c. External Static Pressure)														
		65			85			95			105			115		
		Btuh	S/T	kW	Btuh	S/T	kW	Btuh	S/T	kW	Btuh	S/T	kW	Btuh	S/T	kW
HWC8**-7-11-12P	85/72	15,300	0.61	0.95	14,600	0.63	1.09	13,100	0.69	1.24	12,400	0.71	1.36	11,000	0.76	1.48
	80/67	14,300	0.68	0.95	13,700	0.72	1.09	12,000	0.75	1.23	11,400	0.80	1.35	10,200	0.85	1.47
	75/63	13,500	0.72	0.95	12,300	0.76	1.07	11,300	0.81	1.22	10,000	0.85	1.32	9,500	0.93	1.45
	75/57	12,400	1.00	0.94	11,600	1.00	1.12	11,100	1.00	1.21	9,400	1.00	1.30	9,000	1.00	1.43
HWC8**-7-12-12P	85/72	15,300	0.61	0.95	14,600	0.63	1.09	13,100	0.69	1.24	12,400	0.71	1.36	11,000	0.76	1.48
	80/67	14,300	0.68	0.95	13,700	0.72	1.09	12,000	0.75	1.23	11,400	0.80	1.35	10,200	0.85	1.47
	75/63	13,500	0.72	0.95	12,300	0.76	1.07	11,300	0.81	1.22	10,000	0.85	1.32	9,500	0.93	1.45
	75/57	12,400	1.00	0.94	11,600	1.00	1.12	11,100	1.00	1.21	9,400	1.00	1.30	9,000	1.00	1.43
HWC8**-7-11-18P	85/72	21,000	0.59	1.28	19,700	0.60	1.52	18,400	0.62	1.68	16,800	0.64	1.80	15,400	0.72	2.10
	80/67	19,300	0.72	1.24	18,500	0.75	1.46	17,000	0.78	1.65	15,400	0.81	1.79	13,800	0.85	1.99
	75/63	18,500	0.76	1.21	17,300	0.79	1.51	15,500	0.81	1.67	14,100	0.85	1.79	12,300	0.89	1.95
	75/57	16,800	1.00	1.20	15,500	1.00	1.50	14,100	1.00	1.67	12,900	1.00	1.78	11,200	1.00	1.94
HWC8**-7-12-18P	85/72	21,000	0.64	1.20	20,000	0.65	1.45	18,900	0.67	1.59	17,200	0.71	1.71	15,200	0.74	1.86
	80/67	19,200	0.72	1.16	18,400	0.74	1.38	16,800	0.77	1.55	15,400	0.80	1.68	13,800	0.85	1.84
	75/63	18,200	0.76	1.14	17,100	0.70	1.44	15,200	0.79	1.58	13,500	0.83	1.66	11,500	0.90	1.82
	75/57	16,700	1.00	1.12	15,900	1.00	1.43	13,800	1.00	1.56	12,600	1.00	1.65	11,000	1.00	1.81
HWC8**-7-11-24P	85/72	29,500	0.63	1.74	27,400	0.63	2.03	25,000	0.64	2.35	22,800	0.66	2.57	20,500	0.70	2.87
	80/67	27,300	0.68	1.69	24,600	0.70	2.02	22,200	0.73	2.32	20,300	0.77	2.55	18,700	0.80	2.86
	75/63	25,500	0.71	1.66	22,800	0.73	2.00	20,600	0.75	2.26	18,800	0.80	2.53	16,900	0.81	2.84
	75/57	22,000	1.00	1.65	20,300	1.00	1.97	19,200	1.00	2.25	17,800	1.00	2.53	16,100	1.00	2.80
HWC8**-7-11-30P	85/72	35,900	0.62	2.41	30,900	0.66	2.75	30,000	0.66	3.11	27,000	0.60	3.34	24,700	0.73	3.56
	80/67	32,500	0.69	2.37	29,900	0.70	2.73	26,800	0.73	3.05	24,300	0.77	3.27	22,500	0.79	3.67
	75/63	29,900	0.71	2.34	28,500	0.86	2.72	24,600	0.77	3.02	22,100	0.80	3.25	19,700	0.85	3.45
	75/57	26,400	1.00	2.33	27,300	1.00	2.71	22,900	1.00	2.99	20,800	1.00	3.23	18,700	1.00	3.43
HWC9**-7-11-12P	85/72	15,300	0.61	0.95	14,600	0.63	1.09	13,100	0.69	1.24	12,400	0.71	1.36	11,000	0.76	1.48
	80/67	14,300	0.68	0.95	13,700	0.72	1.09	12,000	0.75	1.23	11,400	0.80	1.35	10,200	0.85	1.47
	75/63	13,500	0.72	0.95	12,300	0.76	1.07	11,300	0.81	1.22	10,000	0.85	1.32	9,500	0.93	1.45
	75/57	12,400	1.00	0.94	11,600	1.00	1.12	11,100	1.00	1.21	9,400	1.00	1.30	9,000	1.00	1.43
HWC9**-7-12-12P	85/72	15,300	0.61	0.95	14,600	0.63	1.09	13,100	0.69	1.24	12,400	0.71	1.36	11,000	0.76	1.48
	80/67	14,300	0.68	0.95	13,700	0.72	1.09	12,000	0.75	1.23	11,400	0.80	1.35	10,200	0.85	1.47
	75/63	13,500	0.72	0.95	12,300	0.76	1.07	11,300	0.81	1.22	10,000	0.85	1.32	9,500	0.93	1.45
	75/57	12,400	1.00	0.94	11,600	1.00	1.12	11,100	1.00	1.21	9,400	1.00	1.30	9,000	1.00	1.43

COOLING PERFORMANCE EXTENDED RATINGS

Model	Indoor Temp DB/ WB °F	Outdoor Temperature - DB °F (0.3" w.c. External Static Pressure)														
		65			85			95			105			115		
		Btuh	S/T	kW	Btuh	S/T	kW	Btuh	S/T	kW	Btuh	S/T	kW	Btuh	S/T	kW
HWC9**-7-11-18P	85/72	21,000	0.59	1.28	19,700	0.60	1.52	18,400	0.62	1.68	16,800	0.64	1.80	15,400	0.72	2.10
	80/67	19,300	0.72	1.24	18,500	0.75	1.46	17,000	0.78	1.65	15,400	0.81	1.79	13,800	0.85	1.99
	75/63	18,500	0.76	1.21	17,300	0.79	1.51	15,500	0.81	1.67	14,100	0.85	1.79	12,300	0.89	1.95
	75/57	16,800	1.00	1.20	15,500	1.00	1.50	14,100	1.00	1.67	12,900	1.00	1.78	11,200	1.00	1.94
HWC9**-7-12-18P	85/72	21,000	0.64	1.20	20,000	0.65	1.45	18,900	0.67	1.59	17,200	0.71	1.71	15,200	0.74	1.86
	80/67	19,200	0.72	1.16	18,400	0.74	1.38	16,800	0.77	1.55	15,400	0.80	1.68	13,800	0.85	1.84
	75/63	18,200	0.76	1.14	17,100	0.70	1.44	15,200	0.79	1.58	13,500	0.83	1.66	11,500	0.90	1.82
	75/57	16,700	1.00	1.12	15,900	1.00	1.43	13,800	1.00	1.56	12,600	1.00	1.65	11,000	1.00	1.81
HWC9**-7-11-24P	85/72	29,500	0.63	1.74	27,400	0.63	2.03	25,000	0.64	2.35	22,800	0.66	2.57	20,500	0.70	2.87
	80/67	27,300	0.68	1.69	24,600	0.70	2.02	22,200	0.73	2.32	20,300	0.77	2.55	18,700	0.80	2.86
	75/63	25,500	0.71	1.66	22,800	0.73	2.00	20,600	0.75	2.26	18,800	0.80	2.53	16,900	0.81	2.84
	75/57	22,000	1.00	1.65	20,300	1.00	1.97	19,200	1.00	2.25	17,800	1.00	2.53	16,100	1.00	2.80
HWC9**-7-11-30P	85/72	35,900	0.62	2.41	30,900	0.66	2.75	30,000	0.66	3.11	27,000	0.60	3.34	24,700	0.73	3.56
	80/67	32,500	0.69	2.37	29,900	0.70	2.73	26,800	0.73	3.05	24,300	0.77	3.27	22,500	0.79	3.67
	75/63	29,900	0.71	2.34	28,500	0.86	2.72	24,600	0.77	3.02	22,100	0.80	3.25	19,700	0.85	3.45
	75/57	26,400	1.00	2.33	27,300	1.00	2.71	22,900	1.00	2.99	H32:P36	1.00	3.23	18,700	1.00	3.43

HWC8 BLOWER PERFORMANCE

SUPPLY AIRFLOW PERFORMANCE (SCFM) AS A FUNCTION OF EXTERNAL STATIC PRESSURE												
Model	Rise Range (°F)	Mid Rise (°F)	Indoor Blower Speed	Unit Voltage (V)	0.1" w.c.		0.2" w.c.		0.3" w.c.		0.4" w.c.	
					SCFM	Temp Rise (°F)	SCFM	Temp Rise (°F)	SCFM	Temp Rise (°F)	SCFM	Temp Rise (°F)
HWC824-7-11-12P HWC824-7-12-12P	25-55	40	TAP 1 (COOL) [†]	208 OR 230	480		460		440		415	
			TAP 2 (COOL)	208 OR 230	530		505		485		460	
			TAP 3 (HEAT)*	208 OR 230	455	39	415	43	385	46	355	50
			TAP 4 (HEAT)	208 OR 230	570	31	540	33	510	35	485	37
			TAP 5 (HEAT)	208 OR 230	655	27	625	28	595	30	575	31
HWC836-7-11-12P HWC836-7-12-12P	35-65	50	TAP 1 (COOL) [†]	208 OR 230	480		460		440		415	
			TAP 2 (COOL)	208 OR 230	530		505		485		460	
			TAP 3 (HEAT)	208 OR 230	455	59	415	N/A	385	N/A	355	N/A
			TAP 4 (HEAT)*	208 OR 230	570	47	540	50	510	53	485	55
			TAP 5 (HEAT)	208 OR 230	655	41	625	43	595	45	575	47
HWC836-7-11-18P HWC836-7-12-18P	25-55	40	TAP 1 (COOL) [†]	208 OR 230	635		610		600		570	
			TAP 2 (COOL)	208 OR 230	670		645		625		605	
			TAP 3 (HEAT)*	208 OR 230	630	42	600	44	570	47	550	48
			TAP 4 (HEAT)	208 OR 230	770	35	740	36	715	37	690	39
			TAP 5 (HEAT)	208 OR 230	885	30	855	31	830	32	810	33
HWC848-7-11-18P HWC848-7-12-18P	35-65	50	TAP 1 (COOL) [†]	208 OR 230	635		610		600		570	
			TAP 2 (COOL)	208 OR 230	670		645		625		605	
			TAP 3 (HEAT)	208 OR 230	630	56	600	59	570	62	550	N/A
			TAP 4 (HEAT)*	208 OR 230	770	46	740	48	715	50	690	52
			TAP 5 (HEAT)	208 OR 230	885	40	855	42	830	43	810	44
HWC860-7-11-18P HWC860-7-12-18P	45-75	60	TAP 1 (COOL) [†]	208 OR 230	635		610		600		570	
			TAP 2 (COOL)	208 OR 230	670		645		625		605	
			TAP 3 (HEAT)	208 OR 230	630	71	600	N/A	570	N/A	550	N/A
			TAP 4 (HEAT)	208 OR 230	770	58	740	60	715	62	690	64
			TAP 5 (HEAT)*	208 OR 230	885	50	855	52	830	54	810	55
HWC836-7-11-24P	25-55	40	TAP 1 (COOL) [†]	208 OR 230	770		750		730		710	
			TAP 2 (COOL)	208 OR 230	820		790		770		750	
			TAP 3 (HEAT)*	208 OR 230	645	42	615	44	590	47	565	48
			TAP 4 (HEAT)	208 OR 230	780	35	755	36	730	37	710	39
			TAP 5 (HEAT)	208 OR 230	900	30	875	31	855	32	835	33
HWC848-7-11-24P	35-65	50	TAP 1 (COOL) [†]	208 OR 230	770		750		730		710	
			TAP 2 (COOL)	208 OR 230	820		790		770		750	
			TAP 3 (HEAT)	208 OR 230	645	55	615	58	590	60	565	63
			TAP 4 (HEAT)*	208 OR 230	780	46	755	47	730	49	710	50
			TAP 5 (HEAT)	208 OR 230	900	40	875	41	855	42	835	43

N/A: Do not operate unit in heating mode using this blower speed at this external static pressure outside of the proper temperature rise range.

NOTE: HWC**30B models shipped with Low and High stage Cooling taps connected for use of the two-stage system.

* As shipped speed for Heating operation

† As shipped speed for Cooling operation

HWC8 BLOWER PERFORMANCE

SUPPLY AIRFLOW PERFORMANCE (SCFM) AS A FUNCTION OF EXTERNAL STATIC PRESSURE												
Model	Rise Range (°F)	Mid Rise (°F)	Indoor Blower Speed	Unit Voltage (V)	0.1" w.c.		0.2" w.c.		0.3" w.c.		0.4" w.c.	
					SCFM	Temp Rise (°F)	SCFM	Temp Rise (°F)	SCFM	Temp Rise (°F)	SCFM	Temp Rise (°F)
HWC860-7-11-24P	45-75	60	TAP 1 (COOL)†	208 OR 230	770		750		730		710	
			TAP 2 (COOL)	208 OR 230	820		790		770		750	
			TAP 3 (HEAT)	208 OR 230	645	69	615	72	590	N/A	565	N/A
			TAP 4 (HEAT)	208 OR 230	780	57	755	59	730	61	710	63
			TAP 5 (HEAT)*	208 OR 230	900	49	875	51	855	52	835	53
HWC848-7-11-30P	30-60	45	TAP 1 (COOL)†	208 OR 230	530		510		490		465	
			TAP 2 (COOL)	208 OR 230	570		545		530		505	
			TAP 3 (COOL)†	208 OR 230	950		920		900		885	
			TAP 4 (HEAT)*	208 OR 230	780	46	755	47	730	49	710	50
			TAP 5 (HEAT)	208 OR 230	900	40	875	41	855	42	835	43
HWC860-7-11-30P	45-75	60	TAP 1 (COOL)†	208 OR 230	530		510		490		465	
			TAP 2 (COOL)	208 OR 230	570		545		530		505	
			TAP 3 (COOL)†	208 OR 230	950		920		900		885	
			TAP 4 (HEAT)	208 OR 230	780	57	755	59	730	61	710	63
			TAP 5 (HEAT)*	208 OR 230	900	49	875	51	855	52	835	53

N/A: Do not operate unit in heating mode using this blower speed at this external static pressure outside of the proper temperature rise range.

NOTE: HWC**30B models shipped with Low and High stage Cooling taps connected for use of the two-stage system.

* As shipped speed for Heating operation

† As shipped speed for Cooling operation

HWC9 BLOWER PERFORMANCE

SUPPLY AIRFLOW PERFORMANCE (SCFM) AS A FUNCTION OF EXTERNAL STATIC PRESSURE												
Model	Rise Range (°F)	Mid Rise (°F)	Indoor Blower Speed	Unit Voltage (V)	0.1" w.c.		0.2" w.c.		0.3" w.c.		0.4" w.c.	
					SCFM	Temp Rise (°F)	SCFM	Temp Rise (°F)	SCFM	Temp Rise (°F)	SCFM	Temp Rise (°F)
HWC922-7-11-12P HWC922-7-12-12P	25-55	40	TAP 1 (COOL)†	208 OR 230	480		460		440		415	
			TAP 2 (COOL)	208 OR 230	530		505		485		460	
			TAP 3 (HEAT)*	208 OR 230	455	42	415	46	385	50	355	54
			TAP 4 (HEAT)	208 OR 230	570	34	540	36	510	38	485	40
			TAP 5 (HEAT)	208 OR 230	655	29	625	31	595	32	575	33
HWC933-7-11-12P HWC933-7-12-12P	36-65	50	TAP 1 (COOL)†	208 OR 230	480		460		440		415	
			TAP 2 (COOL)	208 OR 230	530		505		485		460	
			TAP 3 (HEAT)	208 OR 230	455	63	415	N/A	385	N/A	355	N/A
			TAP 4 (HEAT)*	208 OR 230	570	50	540	53	510	56	485	59
			TAP 5 (HEAT)	208 OR 230	655	44	625	46	595	48	575	50
HWC933-7-11-18P HWC933-7-12-18P	30-60	45	TAP 1 (COOL)†	208 OR 230	635		610		600		570	
			TAP 2 (COOL)	208 OR 230	670		645		625		605	
			TAP 3 (HEAT)*	208 OR 230	630	45	600	48	570	50	550	52
			TAP 4 (HEAT)	208 OR 230	770	37	740	39	715	40	690	42
			TAP 5 (HEAT)	208 OR 230	885	32	855	34	830	35	810	35
HWC944-7-11-18P HWC944-7-12-18P	35-65	50	TAP 1 (COOL)†	208 OR 230	635		610		600		570	
			TAP 2 (COOL)	208 OR 230	670		645		625		605	
			TAP 3 (HEAT)	208 OR 230	630	61	600	64	570	N/A	550	N/A
			TAP 4 (HEAT)*	208 OR 230	770	50	740	52	715	54	690	56
			TAP 5 (HEAT)	208 OR 230	885	43	855	45	830	46	810	47

N/A: Do not operate unit in heating mode using this blower speed at this external static pressure outside of the proper temperature rise range.

NOTE: HWC**30B models shipped with Low and High stage Cooling taps connected for use of the two-stage system.

* As shipped speed for Heating operation

† As shipped speed for Cooling operation

HWC9 BLOWER PERFORMANCE

SUPPLY AIRFLOW PERFORMANCE (SCFM) AS A FUNCTION OF EXTERNAL STATIC PRESSURE												
Model	Rise Range (°F)	Mid Rise (°F)	Indoor Blower Speed	Unit Voltage (V)	0.1" w.c.		0.2" w.c.		0.3" w.c.		0.4" w.c.	
					SCFM	Temp Rise (°F)	SCFM	Temp Rise (°F)	SCFM	Temp Rise (°F)	SCFM	Temp Rise (°F)
HWC955-7-11-18P HWC955-7-12-18P	45-75	60	TAP 1 (COOL)†	208 OR 230	635		610		600		570	
			TAP 2 (COOL)	208 OR 230	670		645		625		605	
			TAP 3 (HEAT)	208 OR 230	630	N/A	600	N/A	570	N/A	550	N/A
			TAP 4 (HEAT)	208 OR 230	770	61	740	64	715	66	690	68
			TAP 5 (HEAT)*	208 OR 230	885	53	855	55	830	57	810	58
HWC9N33-7-11-24P	30-60	45	TAP 1 (COOL)†	208 OR 230	770		750		730		710	
			TAP 2 (COOL)	208 OR 230	820		790		770		750	
			TAP 3 (HEAT)*	208 OR 230	645	44	615	47	590	49	565	51
			TAP 4 (HEAT)	208 OR 230	780	37	755	38	730	39	710	40
			TAP 5 (HEAT)	208 OR 230	900	32	875	33	855	34	835	34
HWC944-7-11-24P	25-55	40	TAP 1 (COOL)†	208 OR 230	770		750		730		710	
			TAP 2 (COOL)	208 OR 230	820		590		770		750	
			TAP 3 (HEAT)	208 OR 230	645	59	615	62	590	65	565	N/A
			TAP 4 (HEAT)*	208 OR 230	780	49	755	51	730	52	710	54
			TAP 5 (HEAT)	208 OR 230	900	43	875	44	855	45	835	46
HWC955-7-11-24P	35-65	50	TAP 1 (COOL)†	208 OR 230	770		750		730		710	
			TAP 2 (COOL)	208 OR 230	820		790		770		750	
			TAP 3 (HEAT)	208 OR 230	645	73	615	N/A	590	N/A	565	N/A
			TAP 4 (HEAT)	208 OR 230	780	61	755	63	730	65	710	67
			TAP 5 (HEAT)*	208 OR 230	900	53	875	54	855	55	835	57
HWC944-7-11-30P	35-65	50	TAP 1 (COOL)†	208 OR 230	530		510		490		465	
			TAP 2 (COOL)	208 OR 230	570		545		530		505	
			TAP 3 (COOL)†	208 OR 230	950		920		900		885	
			TAP 4 (HEAT)*	208 OR 230	780	49	755	51	730	52	710	54
			TAP 5 (HEAT)	208 OR 230	900	43	875	44	855	45	835	46
HWC955-7-11-30P	45-75	60	TAP 1 (COOL)†	208 OR 230	530		510		490		465	
			TAP 2 (COOL)	208 OR 230	570		545		530		505	
			TAP 3 (COOL)†	208 OR 230	950		920		900		885	
			TAP 4 (HEAT)	208 OR 230	780	61	755	63	730	65	710	67
			TAP 5 (HEAT)*	208 OR 230	900	53	875	54	855	55	835	57

N/A: Do not operate unit in heating mode using this blower speed at this external static pressure outside of the proper temperature rise range.

NOTE: HWC**30B models shipped with Low and High stage Cooling taps connected for use of the two-stage system.

* As shipped speed for Heating operation

† As shipped speed for Cooling operation

UNIT DIMENSIONS

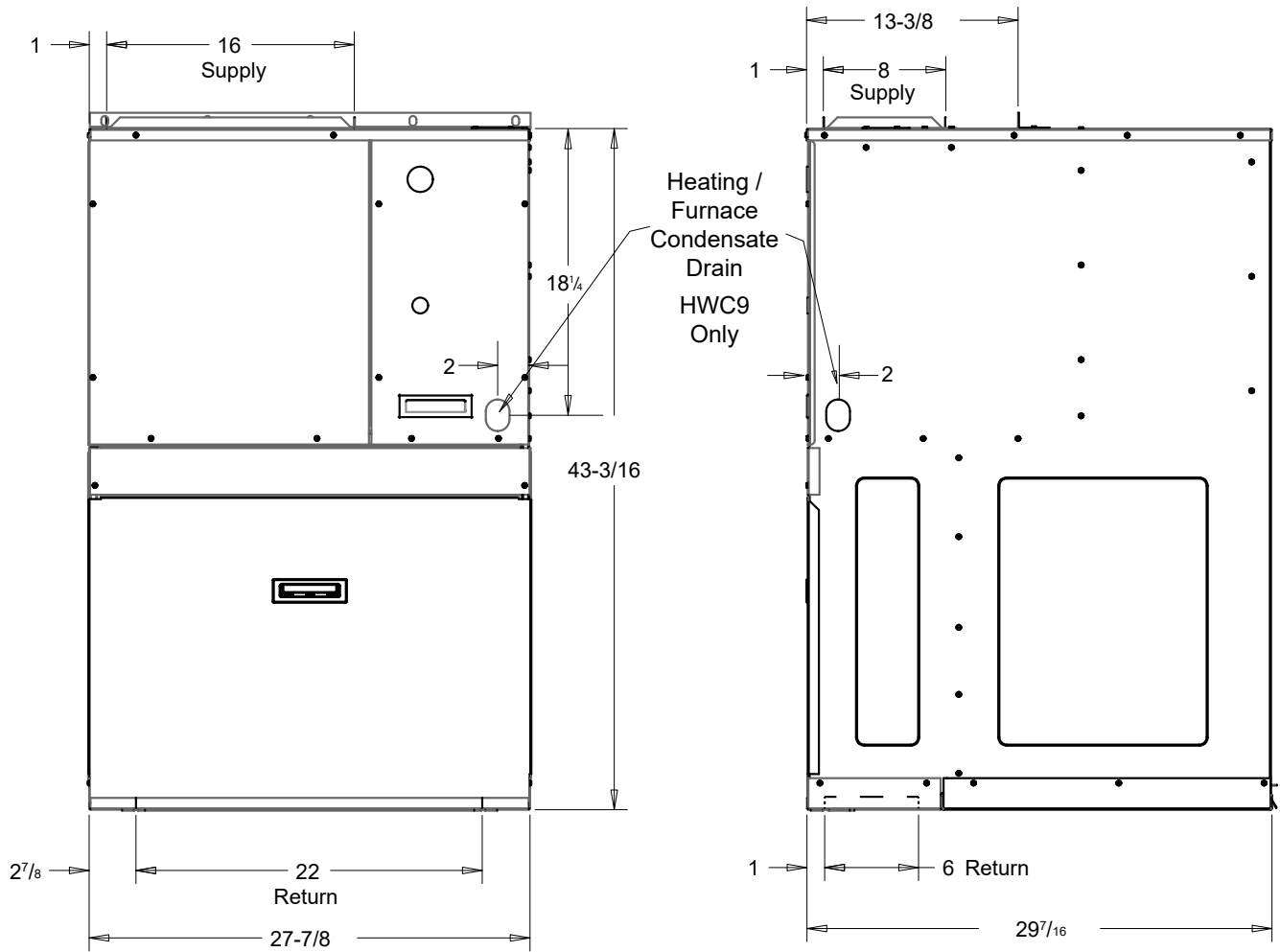
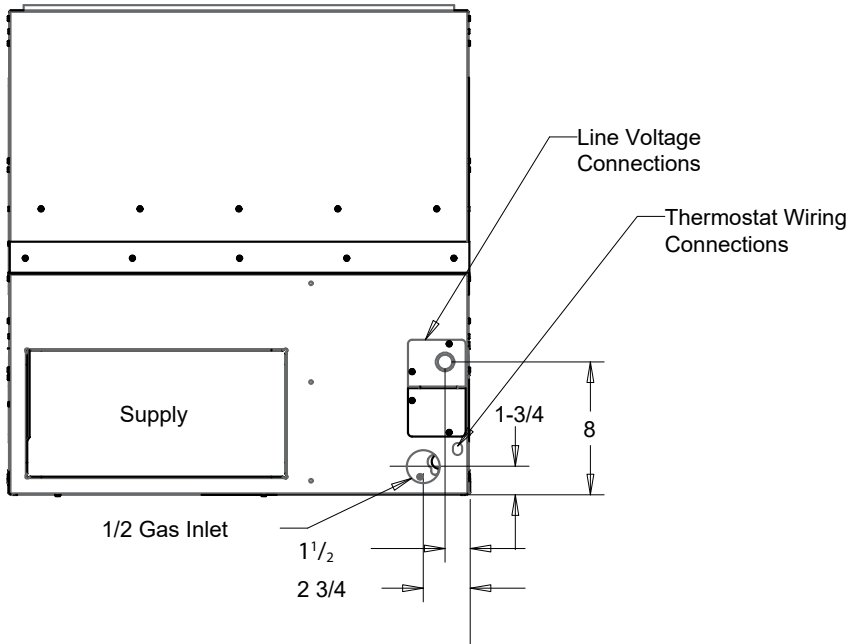

WALL SLEEVE DIMENSIONS

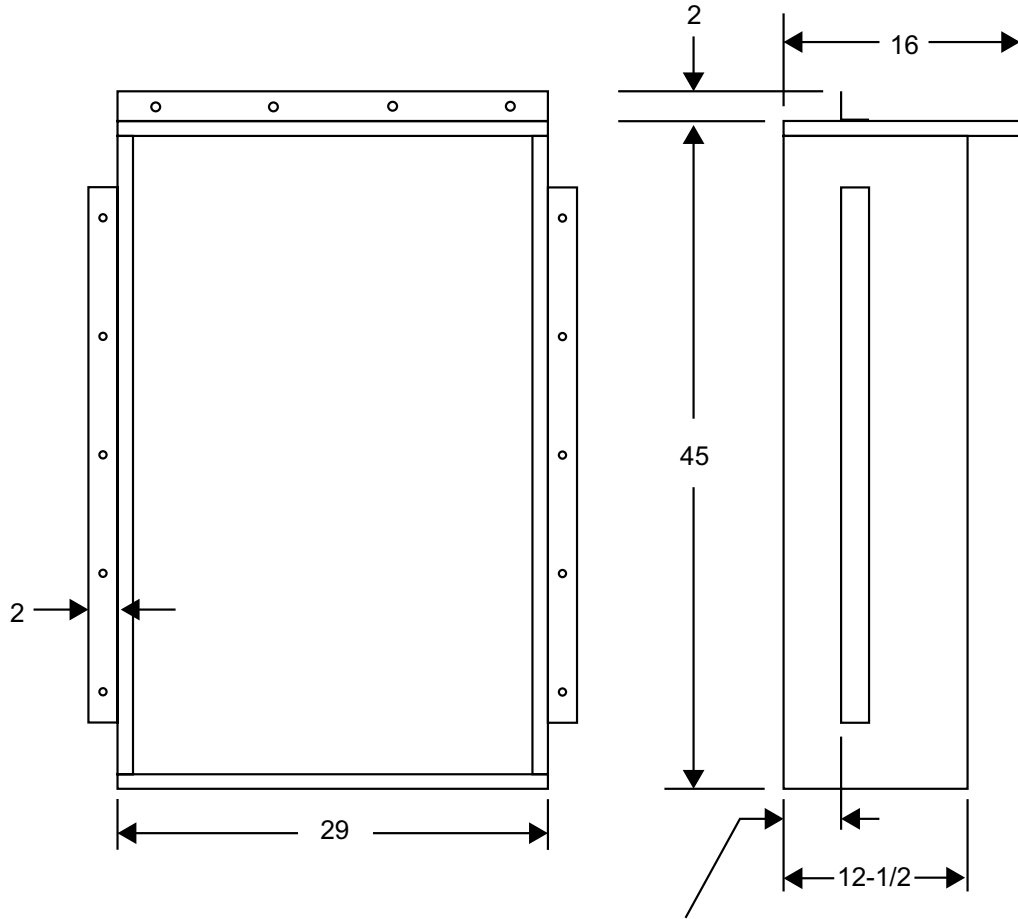

Flange may be assembled
1" or 3-3/4" from front of sleeve

VENT LOCATION

HWC8

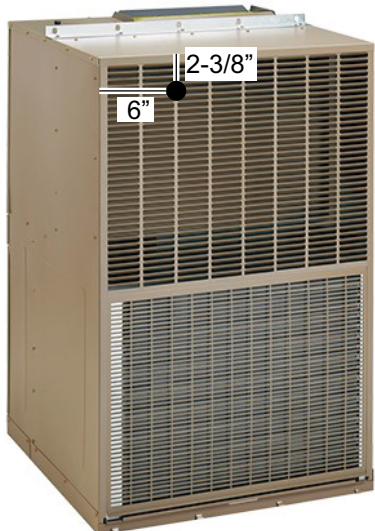

HWC9





215 Metropolitan Drive | West Columbia, SC 29170
800-448-5872
Product Support 866-282-7257
www.magic-pak.com

All specifications and illustrations subject to change
without notice and without incurring obligations.