



INSTALLATION AND MAINTENANCE INSTRUCTIONS

MCE*-7-11/13-* Series

Electric Cooling / Electric Heating Packaged Unit

Save these instructions for future reference



This is a safety alert symbol and should never be ignored. When you see this symbol on labels or in manuals, be alert to the potential for personal injury or death.

Installation

WARNING

These units are not approved for mobile home applications. Such use could result in property damage, personal injury, or death.

Table of Contents

Installation	1
Operation.....	13
Maintenance	14
Accessories	16
Refrigerant Detection System.....	18
Wiring Diagrams	22
Decommissioning	26

General

These instructions explain the recommended method of installation of the MagicPak All-In-One™ HVAC system model MCE4 electric cooling unit and associated electrical wiring. This unit is designed for use with R-454B refrigerant only.

These instructions, and any instructions packaged with mating components and/or accessories, should be carefully read prior to beginning installation. Note particularly any **CAUTIONS** or **WARNINGS** in these instructions and all labels on the units.

WARNING

Improper installation, adjustment, alteration, service or maintenance can cause property damage, personal injury or loss of life. Installation and service must be performed by a licensed professional installer (or equivalent), service agency or the gas supplier.

Manufactured By
Allied Air Enterprises LLC
215 Metropolitan Drive
West Columbia, SC 29170



(P) 508598-01

CAUTION

The installation of this appliance must conform to the requirements of the National Fire Protection Association; the National Electrical Code, ANSI/NFPA No. 70 (latest edition) in the United States; the Canadian Electrical Code Part 1, CSA 22.2 (latest edition) in Canada; and any state or provincial laws or local ordinances. Local authorities having jurisdiction should be consulted before installation is made. Such applicable regulations or requirements take precedence over the general instructions in this manual.

Check that equipment complies with all applicable building codes, laws, and regulations for its intended use prior to installation.

The MCE4 unit is a self-contained electric cooling unit with optional epoxy-coated coils. This unit has been examined for compliance with Canadian Standards Association CAN/CSA-C22.2 No. 236 (latest edition) and Underwriters Laboratories UL 1995. This unit is also in compliance with AHRI Performance Standard 210/240. Any alterations of internal wiring will void these listings and warranties.

These instructions are intended as a general guide only, for use by qualified personnel and do not supersede any national or local codes in any way. Compliance with all local, state, provincial, or national codes pertaining to this type of equipment should be determined prior to installation.

Units certified for less than 2% cabinet leakage using ANSI/ASHRAE 193 (complies with IECC 2015) are identified on the rating plate.

⚠ WARNING

Installation and servicing of air conditioning equipment can be hazardous due to internal refrigerant pressure and live electrical components. Only trained and qualified service personnel should install or service this equipment. Installation and service performed by unqualified persons can result in property damage, personal injury, or death.

⚠ WARNING

For your safety, do not store or use gasoline or other flammable vapors and liquids in the vicinity of this or any other appliance. Such actions could result in property damage, personal injury, or death.

⚠ WARNING

The unit must be installed with approved wall sleeve and louver accessories for safe operation. Improper installations could result in property damage, personal injury, or death. Refer to the **Accessories** section for additional details on wall sleeves and louvers.

Inspection

Upon receipt of equipment, carefully inspect it for possible shipping damage. If damage is found, it should be noted on the carrier's freight bill. Take special care to examine the unit inside the carton if the carton is damaged. File a claim with the transportation company. **If any damage is discovered and reported to the carrier, do not install the unit, as claim may be denied.**

Check the unit rating plate to confirm specifications are as ordered.

Limitations

The unit should be installed in accordance with all national and local safety codes.

Limitations of the unit and appropriate accessories must also be observed.

The outdoor fan is designed to operate against no more than .10" w.c. static pressure.

Minimum and maximum operation conditions must be observed to assure proper system performance. Refer to Table 1 for the ambient operating limitations of the unit.

Outdoor Ambient Air Temperature °F		
Minimum DB	Maximum DB	
Cool	Cool	Heat
65	115	75

Indoor Ambient Air Temperature °F			
Minimum		Maximum	
DB/WB	DB	DB/WB	DB
Cool	Heat	Cool	Heat
62/57	50	90/72	80

DB = Dry Bulb
WB = Wet Bulb

Table 1. Ambient Temperature Limitations

Location

For information on wall sleeves and louver accessories, see the **Accessories** section.

This unit is designed to be installed in up to the wall (exterior wall) installation only. Refer to Figure 2 for additional details.

The outside of the unit may be flush with the face of the exterior wall, and it should not be obstructed with trees, landscape materials, or building structure. Unit can be installed recessed with appropriate wall sleeve accessories. There is no minimum clearance required on locating the unit to an interior corner of a building.

If the unit is installed in a residential garage, it must be located or protected to avoid physical damage by vehicles. The unit must be installed so that no electrical components are exposed to water.

⚠ CAUTION

This unit must be installed level to allow for proper drainage of the unit base pan and indoor drain pan.

⚠ CAUTION

Servicing shall be performed only as recommended by the manufacturer.

⚠ IMPORTANT

The Clean Air Act of 1990 bans the intentional venting of refrigerant (CFCs, HCFCs and HFCs) as of July 1, 1992. Approved methods of recovery, recycling or reclaiming must be followed. Fines and/or incarceration may be levied for noncompliance.

⚠ WARNING

Ducts connected to an appliance shall not contain a potential ignition source

⚠ WARNING

- Do not use means to accelerate the defrosting process or to clean, other than those recommended by the manufacturer.
- The appliance shall be stored in a room without continuously operating ignition sources (for example: open flames, an operating gas appliance, or an operating electric heater).
- Do not pierce or burn.
- Be aware that refrigerants may not contain an odor.

⚠ WARNING

For appliances using A2L refrigerants connected via an air duct system to one or more rooms, only auxiliary devices approved by the appliance manufacturer or declared suitable with the refrigerant shall be installed in connecting ductwork.

⚠ WARNING

Every working procedure that affects safety means shall only be carried out by competent persons. This appliance is not to be used by persons (including children) with reduced physical, sensory or mental capabilities, or lack of experience and knowledge, unless they have been given supervision or instruction concerning use of the appliance by a person responsible for their safety. Children should be supervised to ensure they do not play with the appliance.

⚠ CAUTION

Leak Detection System installed. Unit must be powered except for service.

⚠ WARNING

Ducts connected to an appliance shall not contain a potential ignition source

⚠ WARNING

Auxiliary devices which may be a potential ignition source shall not be installed in the duct work. Examples of such potential ignition sources are hot surfaces with a temperature exceeding 700°C and electric switching devices.

⚠ WARNING

For duct connected appliances, false ceilings or drop ceilings may be used as a return air plenum if a REFRIGERANT DETECTION SYSTEM is provided in the appliance and any external connections are also provided with a sensor immediately below the return air plenum duct joint.

⚠ CAUTION

Any service personnel installing, decommissioning, or performing maintenance on the unit must be properly trained with A2L refrigerants

⚠ WARNING

If this appliance is conditioning a space with an area smaller than T_{Amin}, then that space must be without continuously operating open flames (e.g. an operating gas appliance) or other potential ignition sources (e.g. an operating electric heater or similar hot surface). A flame-producing device may be installed in the same space if the device is provided with an effective flame arrest system.

T_{Amin} Table

Charge (lb)	< 4	4	6	8	10
Charge (kg)	< 1.8	1.8	2.7	3.6	4.5
Minimum Conditioned Area (ft ²)	N/A*	60	90	120	150
Minimum Conditioned Area (m ²)	N/A*	5.6	8.4	11.2	14.0

⚠ IMPORTANT

Verify cabling will not be subject to wear, corrosion, excessive pressure, vibration, sharp edges or any other adverse environmental effects. The check shall also take into account the effects of aging or continual vibration from sources such as compressors or fans.

Use of Unit During Construction

Use of this unit as a construction heater or air conditioner is not recommended during any phase of construction. Very low return air temperature, harmful vapors and operation of the unit with clogged or misplaced filters will damage the unit.

Units may be used for heating or cooling of buildings or structures under construction if the following conditions are met or the warranty will be void:

- The unit must be permanently installed per these installation instructions.
- A room thermostat must control the unit. The use of fixed jumpers that will provide continuous heating is not allowed.
- Supply and return air duct must be provided and sealed to the unit.
- Return air temperature range between 60°F (16°C) and 80°F (27°C) must be maintained.
- MERV 11 or greater air filters must be installed in the system and must be regularly inspected and maintained (e.g., regular static checks and replaced at end of life) during construction.
- Air filters must be replaced upon construction completion.
- The input rate and temperature rise must be set per the unit rating plate.
- One hundred percent (100%) outdoor air must be provided for combustion air requirements during construction.
- The heat exchanger, components, duct system, air filters and evaporator coils must be thoroughly cleaned following final construction cleanup.
- The unit operating conditions (including airflow, cooling operation, ignition, input rate, temperature rise and venting) must be verified according to these installation instructions.

Unit Dimensions (in.)

Model	A	B*	C	D	E	F	G	H	J	K	L	M	N
MCE*-7-11-09*P MCE*-7-11-12*P MCE*-7-11-18*P	43-7/8	16-7/8	25-1/4	21-1/2	18-5/8	19-1/4	6	8	16	17-1/16	3/4	2-1/4	24-5/8
MCE*-7-11-24*P	47-7/8	18-7/8	27-1/4	24-3/8	20-5/8	21-1/4	6	8	16	19-1/16	3/4	2-5/8	26-5/8
MCE*-7-11-30*P	55-7/8	22-7/8	31-1/4	24-3/8	24-5/8	25-1/4	6	11-3/8	10-7/16	22-7/16	3-3/4	1	30-5/8
MCE*-7-13-36*P	67-7/8	26-7/8	35-1/4	24-3/8	28-5/8	29-1/4	10	11-3/8	10-7/16	22-7/16	3-3/4	1	38-5/8
* Dimension B represents the height of the optional front return air duct opening													

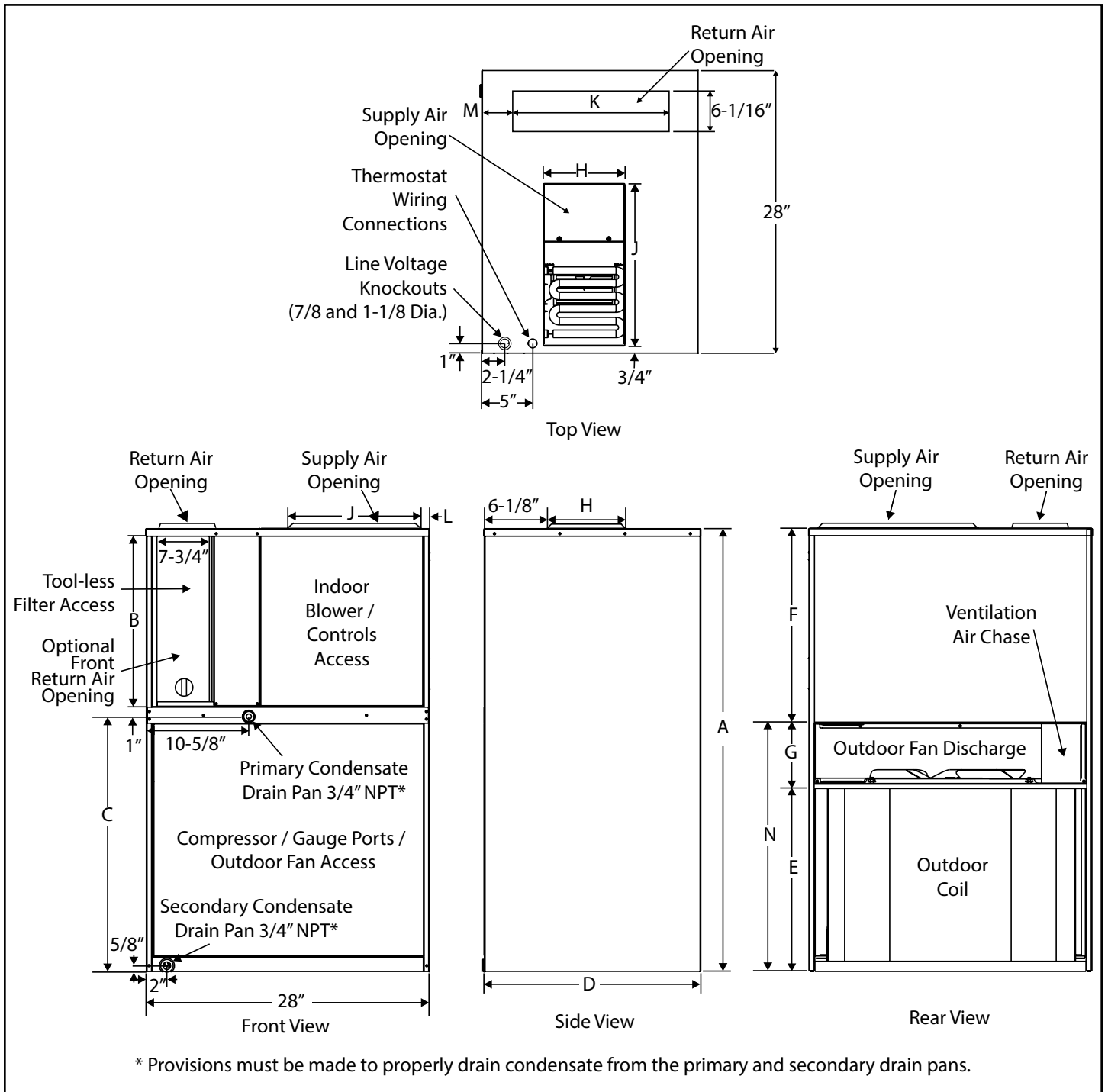

Figure 1.

Accessibility Clearances

The front of the unit must be accessible for service. A minimum clearance of 30" in front of unit is required for service.

If the unit is enclosed, a door or access panel aligned with the front of the unit is the preferred method of providing access. The door or access panel opening must be a minimum of 30" wide (centered on the unit) and be as tall as the unit.

IMPORTANT

The unit must be installed with approved wall sleeve and louver accessories for safe operation. Improper installations could result in property damage, personal injury, or death.

Supply Duct Clearances

Minimum Clearances to Combustible Materials ¹		
Front	Sides	Top
0"	0"	0"

¹ Accessibility clearances take precedence

Unit Clearances

Return Duct Configuration	Unit Height	Minimum Clearances ¹	
		Front	Sides ³
Ducted Top Opening	All	Note 2	1"
Ducted Front Opening ⁵	All	Notes 2 & 4	1"
Non-Ducted/ Free Return	43"	4"	1"
	48" - 68"	5"	1"

¹ Accessibility clearances take precedence

² Clearance must accommodate field-installed condensate drain line / drain trap

³ Additional clearance required if field-installed condensate drain line/drain trap is routed alongside unit

⁴ Consult local codes for other clearance requirements

⁵ If ductwork is attached to the optional front return opening, provisions to service unit filter must be provided

CAUTION

Do not use tools to tighten fitting into drain. Drain lines must be hand tightened.

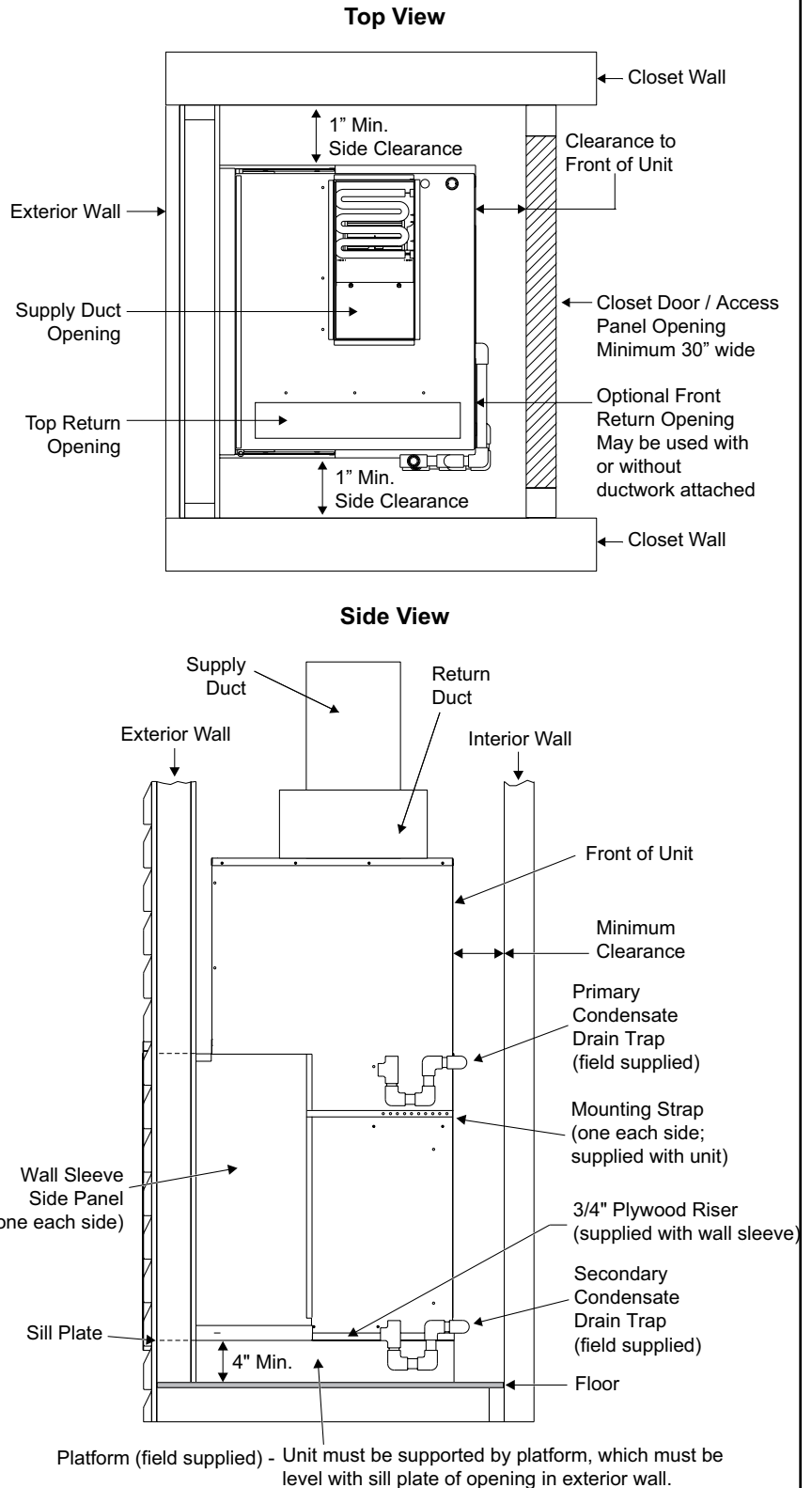

Figure 2. Minimum Clearances

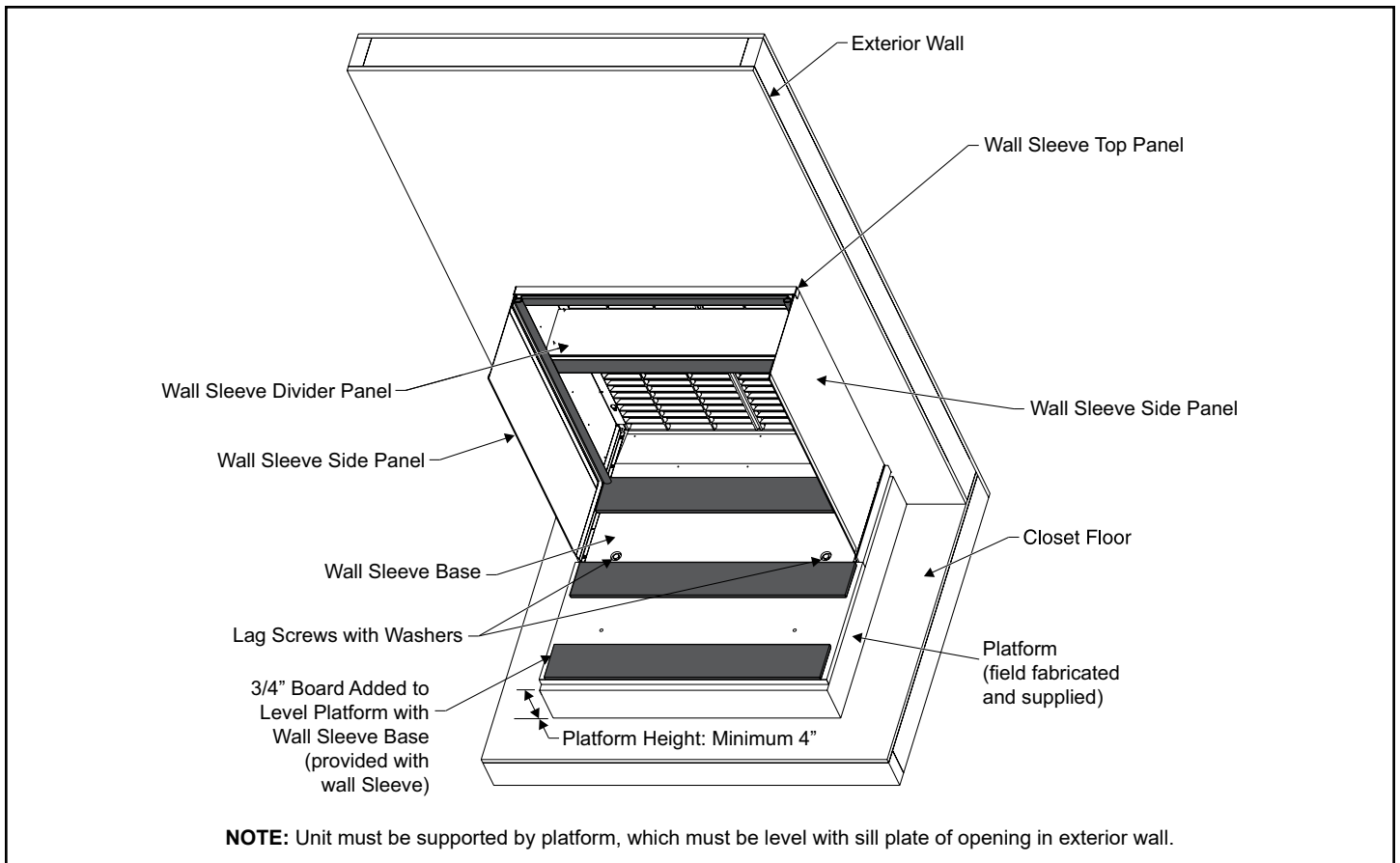

Figure 3. Wall Sleeve and Louver Kit Installation

Wall Sleeve and Louver Installation

Refer to installation instructions included with the wall sleeve kit and the louver along with Figure 3 for guidance in assembling and installing the wall sleeve and louver.

⚠ CAUTION

The sleeve is not intended as the sole support for the unit. An additional support must be provided for adequate support (see Figure 3).

Installing and Securing Unit to Wall Sleeve

1. Before installing and securing the unit to the wall sleeve, make sure that the proper louver is installed.
2. Make sure the gaskets attached to the sleeve are not damaged.
3. Verify divider panel is positioned properly. Refer to Table 2 for wall sleeves that allow for multiple divider panel locations.

Model	ASLEEVE**-2	ASLEEVE**-5	Orientation of Flange
	Two Positions	Three Positions	
MCE*-7-11-09,12,18*	Lower	Lower	Down
MCE*-7-11-24*			
MCE*-7-11-30*	Upper	Middle	Up
MCE*-7-13-36*	N/A	Upper	

Table 2.

4. Place the unit into the wall sleeve. **Lift leading end of unit and walk unit onto the sleeve.** Once in the wall sleeve, lower the unit into position. This prevents damage to the base pads. Assure that the unit is level and completely seated against the gaskets on the wall sleeve. The unit must be supported by a field-supplied base platform.

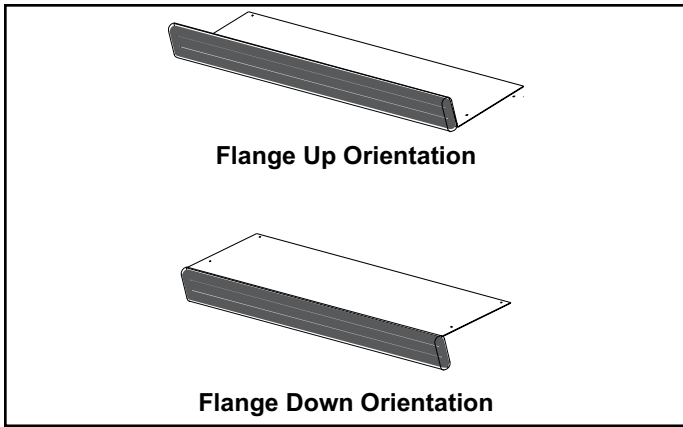

Figure 4. Positioning Divider Panel

5. Use the two installation brackets to secure the unit to the wall sleeve (see Figure 5). The units are shipped with the brackets placed in the return air compartment. Hook each bracket into the front edge of the wall sleeve side. Position the bracket so it can be bent around the front corner of the unit. Remove one of the two screws in that position on the unit. Line up one of the holes in the installation bracket with the screw hole and attach the bracket to the unit with that screw. Make sure to fasten tight enough that the seal is maintained. Trim off excess bracket if applicable.

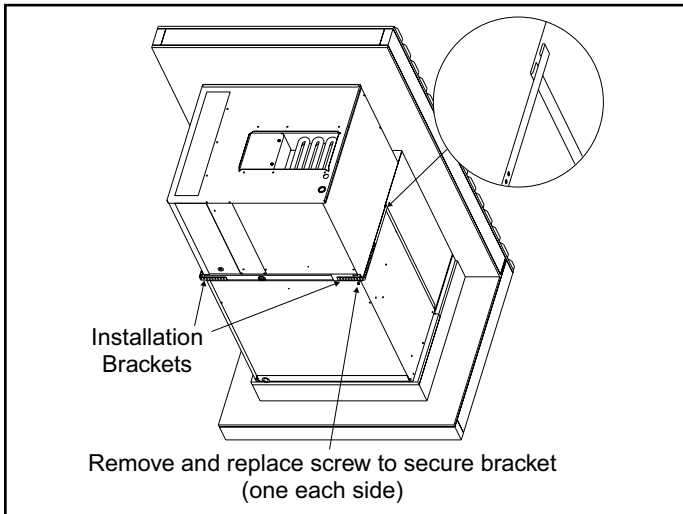

Figure 5. Securing Unit

⚠ CAUTION

Do not screw into the side of the drain pan, the indoor coil or the heat strip, which is located above the installation bracket.

6. Inspect the fit up of the unit to the wall sleeve. Verify that the gaskets of the wall sleeve make a complete seal to the unit paying particular attention to top and bottom corners of unit to sleeve seal. Caulk if needed.

Ductwork

Ductwork should be designed and sized according to the methods in Manual Q of the Air Conditioning Contractors of America (ACCA).

Check unit supply and return air outlets for debris before making ductwork connections.

It is recommended that supply and return duct connections at the unit be made with flexible joints. If flexible ducts are used, a 6" sheet metal starter collar is required.

The supply and return air duct systems should be fabricated per the designed CFM and static requirements of the job (see Table 3). **Ductwork should not be sized to match the dimensions of the duct connections on the unit.** The return duct should be sealed to the unit casing and terminate outside the space containing the unit.

Optional Front Return

As shipped, units are configured for attaching supply and return ductwork to the top of the unit. Return air may be brought in through the optional front return opening. To open the optional front return and close off the top return opening, perform the following steps.

1. Rotate knob to release filter access panel and remove panel.
 - a. For all units except 3-ton models, position filter access panel to close off top return opening. Secure at rear using two sheet metal screws. Secure in front using knob. See Figure 6.
 - b. For 3-ton models, field fabricate a sheet metal panel to close off the top return opening.
2. Seal panel to top of unit with tape or mastic.

NOTE: If ductwork is attached to the optional front return opening, provisions to service unit filter must be provided. Filter may need to be relocated to a suitable location outside the cabinet for ease of service.

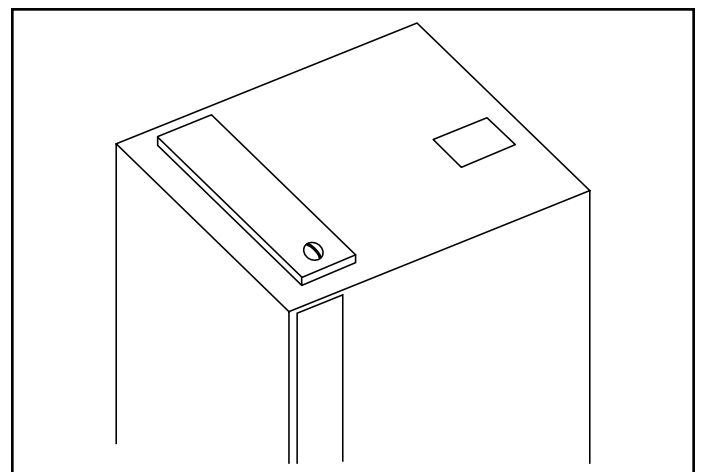

Figure 6. Secure Filter Access Panel

Airflow Performance as a Function of External Static Pressure

Model	Indoor Blower Speed	0.1 "w.c.			0.2 "w.c.			0.3 "w.c.			0.4 "w.c.			0.5 "w.c.			
		SCFM	Watts	HP	SCFM	Watts	HP	SCFM	Watts	HP	SCFM	Watts	HP	SCFM	Watts	HP	
MCE*-7-11-09*P	TAP 1 (FAN)	355	28	0.04	320	31	0.04	275	35	0.05	230	38	0.05	160	42	0.06	
	TAP 2 (COOL)	375	31	0.04	330	33	0.04	285	37	0.05	N/A	N/A	N/A	N/A	N/A	N/A	
	TAP 3 (COOL)†	N/A	N/A	N/A	N/A	N/A	N/A	356	36	0.05	313	40	0.05	280	43	0.06	
	0 kW	TAP 4 (HEAT)*	375	31	0.04	330	33	0.04	285	37	0.05	240	40	0.05	180	44	0.06
		TAP 5 (HEAT)	465	47	0.06	425	51	0.07	390	55	0.07	370	58	0.08	330	62	0.08
	3 kW	TAP 4 (HEAT)*	430	41	0.05	410	45	0.06	385	49	0.07	N/A	N/A	N/A	N/A	N/A	N/A
		TAP 5 (HEAT)	520	58	0.08	500	63	0.08	475	68	0.09	440	73	0.10	400	77	0.10
	5 kW	TAP 4 (HEAT)*	525	59	0.08	505	65	0.09	480	69	0.09	N/A	N/A	N/A	N/A	N/A	N/A
TAP 5 (HEAT)		615	81	0.11	590	88	0.12	560	94	0.13	530	99	0.13	500	103	0.14	
MCE*-7-11-12*P	TAP 1 (FAN)	355	28	0.04	320	31	0.04	275	35	0.05	230	38	0.05	160	42	0.06	
	TAP 2 (COOL)	420	40	0.05	380	42	0.06	355	46	0.06	N/A	N/A	N/A	N/A	N/A	N/A	
	TAP 3 (COOL)†	N/A	N/A	N/A	434	51	0.07	396	55	0.07	356	59	0.08	321	63	0.08	
	0 kW	TAP 4 (HEAT)*	420	40	0.05	380	42	0.06	355	46	0.06	315	50	0.07	275	54	0.07
		TAP 5 (HEAT)	515	58	0.08	480	62	0.08	445	66	0.09	415	70	0.09	380	74	0.10
	3 kW	TAP 4 (HEAT)*	430	41	0.05	410	45	0.06	385	49	0.07	N/A	N/A	N/A	N/A	N/A	N/A
		TAP 5 (HEAT)	520	58	0.08	500	63	0.08	475	68	0.09	440	73	0.10	400	77	0.10
	5 kW	TAP 4 (HEAT)*	525	59	0.08	505	65	0.09	480	69	0.09	N/A	N/A	N/A	N/A	N/A	N/A
TAP 5 (HEAT)		615	81	0.11	590	88	0.12	560	94	0.13	530	99	0.13	500	103	0.14	
MCE*-7-11-18*P	TAP 1 (FAN)	355	28	0.04	320	31	0.04	275	35	0.05	230	38	0.05	160	42	0.06	
	TAP 2 (COOL)	660	103	0.14	640	109	0.15	610	114	0.15	580	119	0.16	550	124	0.17	
	TAP 3 (COOL)†	704	115	0.15	681	121	0.16	658	125	0.17	634	131	0.18	609	135	0.18	
	0 kW	TAP 4 (HEAT)*	660	103	0.14	640	109	0.15	610	114	0.15	580	119	0.16	550	124	0.17
		TAP 5 (HEAT)	725	131	0.18	710	135	0.18	685	140	0.19	660	146	0.20	640	152	0.20
	3 kW	TAP 4 (HEAT)*	430	41	0.05	410	45	0.06	385	49	0.07	N/A	N/A	N/A	N/A	N/A	N/A
		TAP 5 (HEAT)	520	59	0.08	500	63	0.08	475	67	0.09	440	72	0.10	400	77	0.10
	5 kW	TAP 4 (HEAT)*	525	60	0.08	505	65	0.09	480	70	0.09	N/A	N/A	N/A	N/A	N/A	N/A
		TAP 5 (HEAT)	615	81	0.11	590	88	0.12	560	95	0.13	530	100	0.13	500	103	0.14
	7 kW	TAP 4 (HEAT)*	685	108	0.14	670	116	0.16	645	122	0.16	N/A	N/A	N/A	N/A	N/A	N/A
		TAP 5 (HEAT)	N/A	N/A	N/A	770	160	0.21	750	166	0.22	720	172	0.23	700	177	0.24
	10 kW	TAP 4 (HEAT)*	N/A	N/A	N/A	770	160	0.21	750	166	0.22	N/A	N/A	N/A	N/A	N/A	N/A
TAP 5 (HEAT)		N/A	N/A	N/A	N/A	N/A	N/A	N/A	N/A	N/A	820	226	0.30	800	230	0.31	

N/A: Do not operate unit using this blower speed at this external static pressure.

† As shipped speed for Cooling operation. Blower speed must be field adjusted to Speed Tap 2 for lower duct static applications.

* As shipped speed for Heating operation. Blower speed must be field adjusted to Speed Tap 5 for higher duct static applications.

Table 3. Blower Performance (208V or 230V)

Airflow Performance as a Function of External Static Pressure																	
Model	Indoor Blower Speed	0.1 "w.c.			0.2 "w.c.			0.3 "w.c.			0.4 "w.c.			0.5 "w.c.			
		SCFM	Watts	HP	SCFM	Watts	HP	SCFM	Watts	HP	SCFM	Watts	HP	SCFM	Watts	HP	
MCE*-7-11-24*P	TAP 1 (FAN)	455	41	0.05	420	45	0.06	385	49	0.07	365	52	0.07	320	57	0.08	
	TAP 2 (COOL)	810	146	0.20	790	158	0.21	780	166	0.22	755	173	0.23	735	179	0.24	
	TAP 3 (COOL)†	851	177	0.24	829	184	0.25	808	190	0.25	787	197	0.26	758	199	0.27	
	0 kW	TAP 4 (HEAT)*	810	146	0.20	790	158	0.21	780	166	0.22	755	173	0.23	735	179	0.24
		TAP 5 (HEAT)	870	179	0.24	860	184	0.25	845	194	0.26	815	202	0.27	785	206	0.28
	5 kW	TAP 4 (HEAT)*	555	65	0.09	540	69	0.09	510	73	0.10	480	76	0.10	N/A	N/A	N/A
		TAP 5 (HEAT)	645	88	0.12	630	94	0.13	605	100	0.13	580	105	0.14	550	110	0.15
	7 kW	TAP 4 (HEAT)*	775	140	0.19	765	145	0.19	745	150	0.20	725	154	0.21	N/A	N/A	N/A
		TAP 5 (HEAT)	875	184	0.25	865	193	0.26	845	201	0.27	825	208	0.28	800	215	0.29
	10 kW	TAP 4 (HEAT)*	875	184	0.25	865	193	0.26	845	201	0.27	825	208	0.28	N/A	N/A	N/A
		TAP 5 (HEAT)	N/A	N/A	N/A	N/A	N/A	N/A	N/A	N/A	N/A	960	272	0.36	900	276	0.37
	MCE*-7-11-30*P	TAP 1 (FAN)	590	42	0.06	530	48	0.06	430	55	0.07	380	60	0.08	315	65	0.09
TAP 2 (COOL)		1015	152	0.20	985	161	0.22	940	170	0.23	910	177	0.24	875	184	0.25	
TAP 3 (COOL)†		N/A	N/A	N/A	N/A	N/A	N/A	N/A	N/A	N/A	970	227	0.30	950	235	0.32	
0 kW		TAP 4 (HEAT)*	1015	152	0.20	985	161	0.22	940	170	0.23	910	177	0.24	875	184	0.25
		TAP 5 (HEAT)	N/A	N/A	N/A	N/A	N/A	N/A	N/A	N/A	N/A	1015	219	0.29	980	227	0.30
5 kW		TAP 4 (HEAT)*	740	65	0.09	705	74	0.10	640	83	0.11	N/A	N/A	N/A	N/A	N/A	N/A
		TAP 5 (HEAT)	820	81	0.11	790	91	0.12	740	100	0.13	675	109	0.15	600	117	0.16
7 kW		TAP 4 (HEAT)*	860	91	0.12	835	100	0.13	795	108	0.14	N/A	N/A	N/A	N/A	N/A	N/A
		TAP 5 (HEAT)	945	112	0.15	925	122	0.16	885	132	0.18	845	140	0.19	800	148	0.20
10 kW		TAP 4 (HEAT)*	945	112	0.15	925	122	0.16	885	132	0.18	N/A	N/A	N/A	N/A	N/A	N/A
		TAP 5 (HEAT)	N/A	N/A	N/A	N/A	N/A	N/A	980	161	0.22	940	170	0.23	900	179	0.24
MCE*-7-13-36*P		TAP 1 (FAN)	680	61	0.08	630	68	0.09	575	74	0.10	525	79	0.11	460	86	0.12
	TAP 2 (COOL)	1235	260	0.35	1200	272	0.36	1166	284	0.38	1135	295	0.40	1100	305	0.41	
	TAP 3 (COOL)†	N/A	N/A	N/A	N/A	N/A	N/A	1240	302	0.40	1220	314	0.42	1195	326	0.44	
	0 kW	TAP 4 (HEAT)*	1235	260	0.35	1200	272	0.36	1166	284	0.38	1135	295	0.40	1100	305	0.41
		TAP 5 (HEAT)	N/A	N/A	N/A	N/A	N/A	N/A	1250	330	0.44	1215	342	0.46	1180	354	0.47
	5 kW	TAP 4 (HEAT)*	740	75	0.10	695	82	0.11	640	90	0.12	N/A	N/A	N/A	N/A	N/A	N/A
		TAP 5 (HEAT)	815	92	0.12	785	100	0.13	745	108	0.14	700	115	0.15	650	122	0.16
	7 kW	TAP 4 (HEAT)*	815	92	0.12	785	100	0.13	745	108	0.14	N/A	N/A	N/A	N/A	N/A	N/A
		TAP 5 (HEAT)	910	117	0.16	880	126	0.17	840	135	0.18	800	143	0.19	750	150	0.20
	10 kW	TAP 4 (HEAT)*	1010	143	0.19	980	155	0.21	945	166	0.22	N/A	N/A	N/A	N/A	N/A	N/A
		TAP 5 (HEAT)	1085	175	0.23	1065	187	0.25	1030	198	0.27	995	209	0.28	950	219	0.29

N/A: Do not operate unit using this blower speed at this external static pressure.
† As shipped speed for Cooling operation. Blower speed must be field adjusted to Speed Tap 2 for lower duct static applications.
* As shipped speed for Heating operation. Blower speed must be field adjusted to Speed Tap 5 for higher duct static applications.

Table 3. Blower Performance (208V or 230V)

NOTE: This appliance is tested to 0.58 static with a filter and 0.5 static without a filter.

Filter

All return air must be filtered. A washable filter is furnished with the unit, located in the return air compartment. If the optional front return opening is used and a duct is installed, provisions must be made to accommodate filter servicing. **If a filter is installed at a separate central return location, then the factory furnished filter must be removed from the unit.**

The washable filter may be replaced with a disposable filter. Avoid filter with paper frame and media; if it gets wet, it could collapse and block the coil, restricting airflow and causing issues with unit operation. Table 4 lists filter sizes that fit the unit.

Model Number	Filter Size (in.)
MCE*-7-11-09* MCE*-7-11-12* MCE*-7-11-18*	18 x 20 x 1
MCE*-7-11-24*	20 x 22 x 1
MCE*-7-11-30*	22 x 24 x 1
MCE*-7-13-36*	22 x 28 x 1

Table 4. Filter Sizes

When proper duct design is applied, field-provided filters up to MERV 6 can typically be installed in the unit's factory filter location in lieu of a washable filter. If a higher resistance filter is field installed in the unit, the added resistance must be included in the external static pressure and must not exceed 0.5 in. w.c., including ductwork.

If an installation is made in which it is more desirable to mount the filter exterior to the unit, in the return duct work or elsewhere, the washable filter can be used or replaced with a disposable filter. If a disposable filter is used, in lieu of washable filter, use the information provided in Table 5 when sizing the disposable filter.

Model Number	Filter Area (in ²)
MCE*-7-11-09* MCE*-11-12*	250
MCE0*-7-11-18* MCE3*-7-11-18* MCE5*-7-11-18*	310
MCE7*-7-11-18* MCE10*-7-11-18*	380
MCE*-7-11-24*	420
MCE*-7-11-30*	480
MCE*-7-13-36*	575

Table 5. Minimum Required Surface Area for Disposable Filters

Condensate Drain

Provisions must be made to properly drain the primary and secondary drain pans of this appliance.

Primary drain and secondary drain connection: 3/4" NPT to 3/4" PVC fitting (schedule 40 minimum). Both drains must be trapped as shown in Figure 7. The drain line should pitch gradually downward at least 1" per 10' of horizontal run to an open drain.

If local codes require the use of metal condensate lines, do not thread metal fittings into the unit drain pans. Thread a PVC fitting into the unit drain pans and make the field connection to the PVC fitting.

NOTE: *These units are designed with a redundant drain system to handle condensate without the need for an emergency drain pan. Should the indoor coil condensate drain system fail, all water is contained within the unit and the flow is directed into the unit base pan. From there it will drain into the condensate riser. If for some reason the water cannot drain into the main condensate riser, all water is contained in the unit, and the design will allow drainage out through the wall sleeve and louver to the outside of the building.*

CAUTION

Use thread sealant on the threaded fittings. Install threaded fittings by hand only. **Do not over torque the fittings.**

Do not thread metal condensate fittings to unit drain pans.

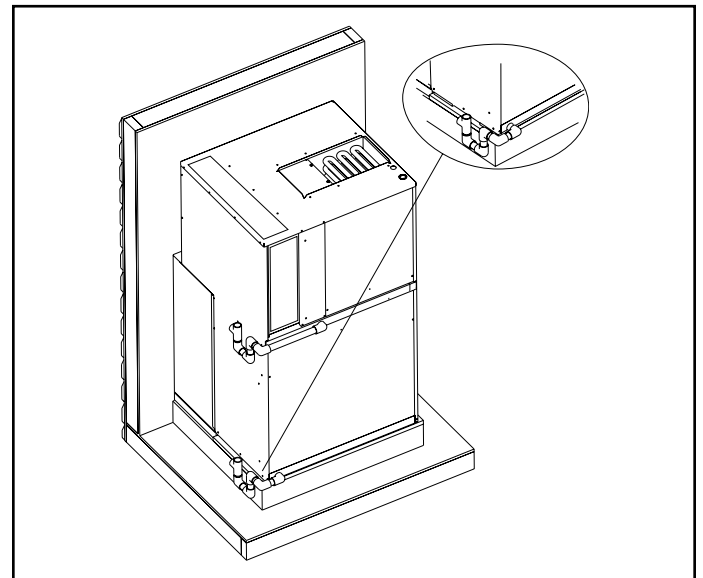

Figure 7. Condensate Drain Installation

Ventilation Air

Units ship with a panel installed that seals the return air compartment at the ventilation air intake. Installers can choose to remove the factory-installed panel and use the field-provided ventilation damper if introduction of ventilation air is desired.

NOTE: *If ventilation air is introduced, the quantity of air and conditions of this air must be accounted for in the load calculations.*

The auxiliary panel has nine knockouts to configure ventilation air flow to installation requirements. Use Table 6 and Figure 8 to determine which knockouts to remove from the auxiliary panel in order to achieve the desired ventilation air flow. Use a flat head screw driver to remove the knockouts. Set the factory-installed panel aside for possible future changes.

⚠ WARNING

The location of ventilation air capable models must conform to the requirements of National Fire Protection Association NFPA No. 54 in regards to proximity of forced air inlets to flue gas terminals. Improper installation could result in personal injury or death.

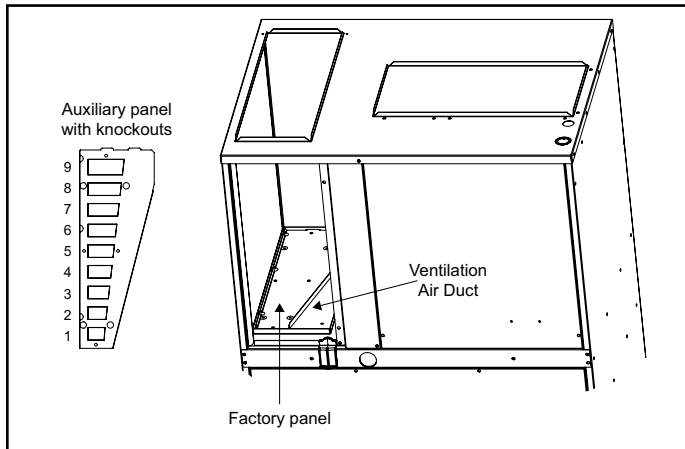

Figure 8. Auxiliary and Factory Panel for Ventilation Air

		Ventilation Air (CFM) *					
		Cumulative Knockouts Removed	Total External Static Pressure (supply + return) **				
			0.1	0.2	0.3	0.4	0.5
0.75, 1.0, 1.5 TON	# 1 Only	7	9	12	15	18	
	#1 thru #2	10	15	20	24	28	
	#1 thru #3	12	18	25	32	38	
	#1 thru #4	18	28	36	45	54	
	#1 thru #5	23	35	46	57	69	
	#1 thru #6	27	41	54	67	80	
	#1 thru #7	32	48	63	78	93	
	#1 thru #8	37	55	73	90	107	
	#1 thru #9	41	61	80	100	118	

2.0, 2.5, 3.0 TON	# 1 Only	21	20	19	17	16
	#1 thru #2	28	27	25	24	22
	#1 thru #3	35	33	32	30	28
	#1 thru #4	45	42	40	38	35
	#1 thru #5	55	52	49	46	43
	#1 thru #6	66	62	59	55	52
	#1 thru #7	79	75	71	66	62
	#1 thru #8	91	86	81	76	71
	#1 thru #9	105	99	94	88	82

* Assumes proper speed tap adjustments to maintain nominal supply air CFM

** Assumes equal supply and return static pressures

Table 6.

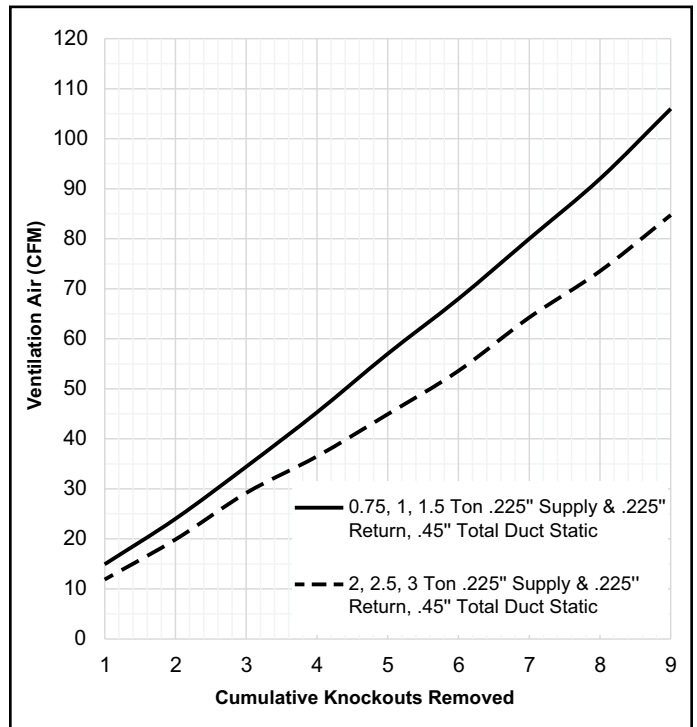

Figure 9. Ventilation Air CFM

Thermostat

The room thermostat should be located on an inside wall where it will not be subject to drafts, sun exposure, or heat from electrical fixtures or appliances. Follow manufacturer's instructions enclosed with the thermostat for general installation procedures. Color-coded insulated wires (#18 AWG) should be used to connect the thermostat to the unit.

Electrical Connections

The unit must be electrically grounded in accordance with local codes or, in the absence of local codes, with the National Electrical Code ANSI/NFPA No. 70 (latest edition) or CSA C22.2 Part 1 (latest edition). Any alteration of internal wiring will void certification and warranty.

Units are factory wired for a 230 volt power supply. If power supply is 208 volts, it will be necessary to change a wire connection on unit transformer from 240 volt terminal to 208 volt terminal as shown on the wiring diagram.

Use wiring with a temperature limitation of 75°F minimum. Run the 208 or 230 volt, single phase, 60 hertz electric power supply through a fused disconnect switch to the control box of the unit and connect as shown in the unit's wiring diagram.

The power supply to the unit must be NEC Class 1 and must comply with all applicable codes. A fused disconnect switch should be field provided for the unit, and must be separate from all other circuits. If any of the wire supplied with the unit must be replaced, replacement wire must be of the type shown on the wiring diagram.

Electrical wiring must be sized to minimum circuit ampacity (MCA) marked on the unit. **Use copper conductors only.** Each unit must be wired with a separate branch circuit and be properly fused.

Operation

Sequence of Operation

Upon initial "power up" to unit, there is a 3-minute time delay to the compressor contactor (R to Y). Any 24V interrupt (R, C) to the defrost control will initiate the 3-minute delay to the contactor.

Cooling

When the thermostat is in the cooling mode, the O circuit is powered which energizes the reversing valve. Upon cooling demand, the thermostat closes circuit R to Y and G. Closing R to Y closes the unit contactor, starting the compressor and outdoor fan, and signaling the indoor blower to run at cooling speed. Upon satisfying cooling demand, the thermostat will open the above circuits and open the main contactor, stopping the compressor and outdoor fan. The unit is equipped with a blower OFF delay; the blower will continue to operate for a fixed 90 seconds after the thermostat is satisfied.

Heating

Upon heating demand, the thermostat closes circuit R to W. On units supplied with heat strips, the sequencers are then energized and bring on the auxiliary electric heat. Units with no factory heat installed contain an auxiliary heat relay that will close, energizing the 24VAC output. This output can be used to control (not power) an auxiliary heat source. The W signal from the thermostat brings the indoor blower on at electric heat speed. Upon satisfying heating demand, the thermostat opens the above circuits and stops unit operation.

The unit is equipped with a blower OFF delay; the blower will continue to operate for a fixed 120 seconds (electric heat) after the thermostat is satisfied.

NOTE 1: *The 7.2 and 10 kW heats strips offer a W1 and W2 thermostat connection. Taking advantage of the two heat strip circuits requires a 2-stage thermostat (W1 for electric heat stage 1 and W2 for electric heat stage 2). If a single stage thermostat is used, "pigtail" W1 and W2 wires together when connecting the thermostat wires at the unit.*

NOTE 2: *The primary thermal cut-out switch(120-35°F cut-off) is self-resetting. The backup thermal cut-out switch (160°F cut-off) is nonself-resetting.*

WARNING

Disconnect all electrical power to the unit before conducting any maintenance procedures. Failure to disconnect the power could result in personal injury or death.

Every working procedure that affects safety means shall only be carried out by competent persons. This appliance is not to be used by persons (including children) with reduced physical, sensory or mental capabilities, or lack of experience and knowledge, unless they have been given supervision or instruction concerning use of the appliance by a person responsible for their safety.

- Work shall be undertaken under a controlled procedure so as to minimize the risk of a flammable gas or vapor being present while the work is being performed.
- The area shall be checked with an appropriate refrigerant detector prior to and during work, to ensure the technician is aware of potentially toxic or flammable atmospheres. Ensure that the leak detection equipment being used is suitable for use with all applicable refrigerants, i. e. non-sparking, adequately sealed or intrinsically safe.
- If any hot work is to be conducted on the refrigerating equipment or any associated parts, the appropriate fire extinguishing equipment shall be available to hand. Have a dry powder or CO₂ fire extinguisher adjacent to the charging area.
- No person carrying out work in relation to a refrigerating system which involves exposing any pipe work shall use any sources of ignition in such a manner that it may lead to the risk of fire or explosion. All possible ignition sources, including cigarette smoking, should be kept sufficiently far away from the site of installation, repairing, removing and disposal, during which refrigerant can possibly be released to the surrounding space. Prior to work taking place, the area around the equipment is to be surveyed to make sure that there are no flammable hazards or ignition risks. "No Smoking" signs shall be displayed.
- Ensure that the area is in the open or that it is adequately ventilated before breaking into the system or conducting any hot work. A degree of ventilation shall continue during the period that the work is carried out.
- Pipe-work including piping material, pipe routing, and installation shall include protection from physical damage in operation and service, and be in compliance with national and local codes and standards

- All field joints shall be accessible for inspection prior to being covered or enclosed
- Where electrical components are being changed, they shall be fit for the purpose and to the correct specification. At all times the manufacturer's maintenance and service guidelines shall be followed. If in doubt, consult the manufacturer's technical department for assistance. The following checks shall be applied to installations using **FLAMMABLE REFRIGERANTS** as applicable:
 1. The actual refrigerant charge is in accordance with the room size within which the refrigerant containing parts are installed.
 2. The ventilation machinery and outlets are operating adequately and are not obstructed.
 3. If an indirect refrigerating circuit is being used, the secondary circuit shall be checked for the presence of refrigerant.
 4. Markings on the equipment should be visible and legible. Markings and signs that are illegible shall be corrected.
 5. Refrigerating pipe or components are installed in a position where they are unlikely to be exposed to any substance which may corrode refrigerant containing components, unless the components are constructed of materials which are inherently resistant to being corroded or are suitably protected against being so corroded.'
- For systems containing refrigerant, all repair and maintenance to electrical components shall include initial safety checks and component inspection procedures such as that capacitors are discharged in a safe manner to avoid possibility of sparking, that no live electrical components and wiring are exposed while charging, recovering, or purging the system, and that there is continuity of earth bonding. If a fault exists that could compromise safety, then no electrical supply shall be connected to the circuit until it is satisfactorily dealt with. If the fault cannot be corrected immediately but it is necessary to continue operation, an adequate temporary solution shall be used that is reported to the owner of the equipment, so all parties are advised.

NOTE – Sealed electrical components shall be replaced, not repaired.

NOTE – Intrinsically safe components must be replaced, not repaired.

NOTE – All maintenance staff and others working in the local area shall be instructed on the nature of work being carried out with work in confined spaces being avoided.

- Under no circumstances shall potential sources of ignition be used in the searching for or detection of refrigerant leaks. A halide torch (or any other detector using a naked flame) shall not be used. The following leak detection methods are deemed acceptable for all refrigerant systems. Electronic leak detectors may be used to detect refrigerant leaks but, in the case of flammable refrigerants, the sensitivity may not be adequate, or may need re-calibration. (Detection equipment shall be calibrated in a refrigerant-free area.) Ensure that the detector is not a potential source of ignition and is suitable for the refrigerant used. Leak detection equipment shall be set at a percentage of the LFL of the refrigerant and shall be calibrated to the refrigerant employed, and that 12.5 % refrigerant is confirmed. Leak detection fluids are also suitable for use with most refrigerants but the use of detergents containing chlorine shall be avoided as the chlorine may react with the refrigerant and corrode the copper pipe-work. If a leak is suspected, all naked flames shall be removed/extinguished. If a leakage of refrigerant is found which requires brazing, all of the refrigerant shall be recovered from the system, or isolated (by means of shut of valves) in a part of the system remote from the leak.
- When breaking into the refrigerant circuit to make repairs – or for any other purpose – conventional procedures shall be used. However, for flammable refrigerants it is important that best practice be followed and, since flammability is a consideration, procedures such as safely remove refrigerant following local and national regulations, purging the circuit with inert gas, evacuating (optional for A2L), purging with inert gas (optional for A2L), or opening the circuit by cutting or brazing be adhered to. The refrigerant charge shall be recovered into the correct recovery cylinders if venting is not allowed by local and national codes. For appliances containing flammable refrigerants, the system shall be purged with oxygen-free nitrogen to render the appliance safe for flammable refrigerants. This process might need to be repeated several times. Compressed air or oxygen shall not be used for purging refrigerant systems. For appliances containing flammable refrigerants, refrigerants purging shall be achieved by breaking the vacuum in the system with oxygen-free nitrogen and continuing to fill until the working pressure is achieved, then venting to atmosphere, and finally pulling down to a vacuum (optional for A2L). This process shall be repeated until no refrigerant is within the system (optional for A2L). When the final oxygen-free nitrogen charge is used, the system shall be vented down to atmospheric pressure to be able to perform the required work. Ensure that the outlet for the vacuum pump is not

close to any potential ignition sources and working area is well ventilated.

The refrigeration system normally requires no maintenance since it is a closed, self-contained system.

Periodic inspection and maintenance normally consists of changing or cleaning filters and (under some conditions) cleaning the coils.

Filter

Inspect the filter once a month. Replace disposable filter or clean the washable filter as necessary (a minimum of three times each heating or cooling season is recommended).

To clean the washable filter, shake filter to remove excess dirt and/or use a vacuum cleaner. Wash filter in soap or detergent water and replace after filter is dry. **Motors**
The indoor and outdoor fan motors are permanently lubricated and require no maintenance.

Outdoor Coil

Foreign material should not be allowed to accumulate on the outdoor coil surface or other parts in the air circuit. Cleaning should be as often as necessary to keep the coil clean. To clean the coil, remove the lower access panel and blow out debris by using compressed air or water. **Be sure power to unit is shut off before using water to clean the coil.**

Care should be used when cleaning the coils so that the coil fins are not damaged.

Primary and Secondary Condensate Drain

Foreign material should not be allowed to clog the drain hole. Inspect and clear drain opening prior to each heating and cooling season.

Accessories

! WARNING

The unit must be installed with approved wall sleeve and louver accessories for safe operation. Improper installations could result in property damage, personal injury, or death.

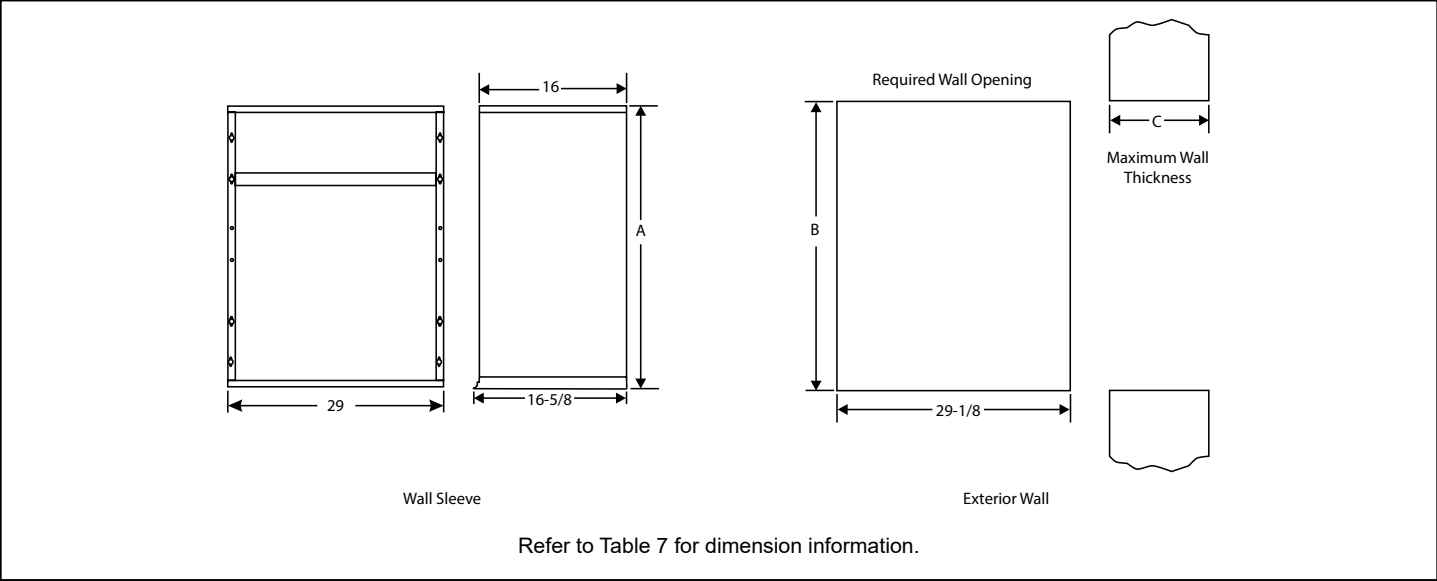

Figure 10.

Wall Sleeves		Louvers			Model						Dimensions (in.)			
Wall Sleeve	Wall Sleeve Extension	Polypropylene Louvers	Aluminum Louvers	Impact Louvers	MCE*-7-11-09*P	MCE*-7-11-12*P	MCE*-7-11-18*P	MCE*-7-11-24*P	MCE*-7-11-30*P	MCE*-7-13-36*P	Wall Sleeve	Wall Opening		
											Height (A)	Height (B)	Depth (C)	
											Height (A)	Height (B)	Sleeve Only	Sleeve Plus Extension
ASLEEVE6-1	---	ALVRP***-1	ALVRAL-1^	ALVRALC-1^	•	•	•	•			29	29-1/8	6	---
ASLEEVE8-1	---	ALVRP***-1	ALVRAL-1^	ALVRALC-1^	•	•	•	•			29	29-1/8	8	---
ASLEEVE10-1	ASLEEVEEXT4-1	ALVRP***-1	ALVRAL-1^	ALVRALC-1^	•	•	•	•			29	29-1/8	10	14
ASLEEVE12-1	ASLEEVEEXT4-1	ALVRP***-1	ALVRAL-1^	ALVRALC-1^	•	•	•	•			29	29-1/8	12	16
ASLEEVE6-2	---	ALVRP***-2	ALVRAL-2^	ALVRALC-2^						•	32-3/4	32-7/8	6	---
ASLEEVE8-2	---	ALVRP***-2	ALVRAL-2^	ALVRALC-2^						•	32-3/4	32-7/8	8	---
ASLEEVE10-2	ASLEEVEEXT4-2	ALVRP***-2	ALVRAL-2^	ALVRALC-2^						•	32-3/4	32-7/8	10	14
ASLEEVE12-2	ASLEEVEEXT4-2	ALVRP***-2	ALVRAL-2^	ALVRALC-2^						•	32-3/4	32-7/8	12	16
ASLEEVE6-2	---	ALVRP***-2	ALVRAL-7^	ALVRALC-7^	◦	◦	◦	◦			32-3/4	32-7/8	6	---
ASLEEVE8-2	---	ALVRP***-2	ALVRAL-7^	ALVRALC-7^	◦	◦	◦	◦			32-3/4	32-7/8	8	---
ASLEEVE10-2	ASLEEVEEXT4-2	ALVRP***-2	ALVRAL-7^	ALVRALC-7^	◦	◦	◦	◦			32-3/4	32-7/8	10	14
ASLEEVE12-2	ASLEEVEEXT4-2	ALVRP***-2	ALVRAL-7^	ALVRALC-7^	◦	◦	◦	◦			32-3/4	32-7/8	12	16
ASLEEVE6-5	---	ALVRP***-3	---	---	◦	◦	◦	◦	◦	•	45	45-1/8	6	---
ASLEEVE8-5	---	ALVRP***-3	---	---	◦	◦	◦	◦	◦	•	45	45-1/8	8	---
ASLEEVE10-5	ASLEEVEEXT4-3	ALVRP***-3	---	---	◦	◦	◦	◦	◦	•	45	45-1/8	10	14
ASLEEVE12-5	ASLEEVEEXT4-3	ALVRP***-3	---	---	◦	◦	◦	◦	◦	•	45	45-1/8	12	16
ASLEEVE6-5	---	---	ALVRAL-3^	ALVRALC-3^	◦	◦	◦	◦			45	45-1/8	6	---
ASLEEVE8-5	---	---	ALVRAL-3^	ALVRALC-3^	◦	◦	◦	◦			45	45-1/8	8	---
ASLEEVE10-5	ASLEEVEEXT4-3	---	ALVRAL-3^	ALVRALC-3^	◦	◦	◦	◦			45	45-1/8	10	14
ASLEEVE12-5	ASLEEVEEXT4-3	---	ALVRAL-3^	ALVRALC-3^	◦	◦	◦	◦			45	45-1/8	12	16
ASLEEVE6-5	---	---	ALVRAL-4^	ALVRALC-4^						◦	45	45-1/8	6	---
ASLEEVE8-5	---	---	ALVRAL-4^	ALVRALC-4^						◦	45	45-1/8	8	---
ASLEEVE10-5	ASLEEVEEXT4-3	---	ALVRAL-4^	ALVRALC-4^						◦	45	45-1/8	10	14
ASLEEVE12-5	ASLEEVEEXT4-3	---	ALVRAL-4^	ALVRALC-4^						◦	45	45-1/8	12	16

Note: Wall Sleeve and Louver size must be coordinated
 *** Louver colors: WHT = white, SAN = sandstone, BGE = beige, TPST = taupestone
 ^ -P: Option to paint standard, aluminum, and impact-resistant louvers
 • Wall sleeve and louver sizes equal to the required wall opening dimensions for the unit size
 ◦ Optional: Wall sleeves and louvers can be oversized to maintain a uniform appearance

Table 7. Accessories

Refrigerant Detection System



FIGURE 11. Example of Clear, Unobstructed Sensor Inlet

Model	RDS Factory Installed	RDS KIT Compatible
MCE*-7-11-09*P		×
MCE*-7-11-12*P		×
MCE*-7-11-18*P		×
MCE*-7-11-24*P	×	
MCE*-7-11-30*P	×	
MCE*-7-13-36*P	×	

Table 8. MCE RDS Table

Sensor Maintenance

It is recommended to check the state of the sensor every 6 months, at the beginning of each cooling and heating season.

- Ensure that the sensor opening is clear and free of debris.
- Check that the sensor cable is in good condition.
- DO NOT use abrasive cleaning solutions or detergents to clean sensor opening.
- DO NOT use flammable compressed air solutions to clean the sensor opening.
- DO NOT vacuum sensor inlet opening, as this could cause damage to the sensor internal components.
- Replace sensor if the opening is not clean or free of debris
- When cleaning the evaporator coil, remove sensor from the coil. Follow recommended coil cleaning guidelines as described in installation instructions.

Modes of Operation

The modes of operation for the RDS Non-Communicating Blower Control Board are Initializing, Normal, Leak Detected, and Fault.

Initializing

The RDS Non-Communicating Blower Control Board is establishing connection with the refrigerant detection sensor and is completing an initial five (5) minute purge sequence.

Normal

The HVAC system is functioning normally. The RDS Non-Communicating Blower Control Board has not detected a refrigerant leak.

Leak Detected

When the RDS Non-Communicating Blower Control Board detects a refrigerant leak:

- 1 - The RDS Non-Communicating Blower Control Board shuts off the (R) input (24VAC power) to the thermostat, which de-energizes the unit compressor and heat sources, such as gas and/or electric strip heat. No heating or cooling demands will be met.
- 2 - The RDS Non-Communicating Blower Control Board activates the blower (high speed). The blower purges refrigerant from the cabinet, plenum, and ductwork.
- 3 - After the RDS Non-Communicating Blower Control Board determines the refrigerant levels are below the safety threshold, the blower will continue to function for an additional seven (7) minutes.
- 4 - After the blower sequence is complete, the HVAC system resumes normal operation.

NOTE – The HVAC system may not maintain a cooling or heating setpoint if a significant leak exists. Any refrigerant leaks that remain unaddressed for an extended time may cause the HVAC system to shut down on a low refrigerant pressure limit condition.

Table 9. Minimum Circulation Airflow

Model	Charge	Qmin		Fan CFM	Minimum Velocity	
	OZ	m3/hr	ft3/min	Tap 1@ 0.1	ft/min	m/s
MCE*-7-11-24*P	64	184	108	455	512	2.60
MCE*-7-11-30*P	64	184	108	590	716	3.64
MCE*-7-13-36*P	82	236	139	680	825	4.19

Fault

When a fault is detected within the RDS Non-Communicating Blower Control Board, the indoor unit blower engages and remains engaged at a constant output until the fault is cleared.

Diagnostic Codes

The RDS Non-Communicating Blower Control Board is equipped with a multi color LED within its enclosure. The LED signals the state of the RDS Non-Communicating Blower Control Board.

See Table 10 to review the diagnostic codes.

TABLE 10. LED Diagnostic Codes

State	LED Diagnostic Code	Action
Initializing	Flashing green ¹	Not Applicable
Monitoring	Solid green with blue flash ²	Not Applicable
Mitigating (Leak Detected)	Flashing blue	Check coil tubes for leak. Repair the issue and restart the equipment.
Fault/Service	Solid blue, interrupted by issue flash code	Refer to Table 16 for troubleshooting steps.

1. A rapid flash indicates the RDSC is in the process of sensor enumeration

2. A blue flash indicates the mitigation process has previously occurred.

Red LED Diagnostic Codes

Red diagnostic codes indicate a specific RDS Non-Communicating Blower Control Board issue. Yellow diagnostic codes indicate the sensor's position (if applicable).

TABLE 11. Red LED Diagnostic Codes

Red Flash	Applies to Individual Sensor(s)	Issue	Action
1	Yes	Sensor indicates fault	Replace the sensor
2	No	Spare Code - Unused	Not Applicable
3	Yes	Incompatible sensor type	Replace with a compatible sensor
4	Yes	Sensor communications issue	Check sensor connection. Ensure connection is clean and tight.
5	No	R-input not available	Check for 24VAC power connection to the R terminal inputs on the RDSC. R-inputs must be energized for the RDSC to function.
6	No	Invalid configuration of sensor count	Verify the DIP switch setting is correct and matches the number of sensors being used.

Test Button Functionality

The RDS Non-Communicating Blower Control Board is equipped with a Test/Reset button. The Test button can be used to complete several functions, depending on the mode of operation of the RDS Non-Communicating Blower Control Board.

Table 12 lists the functions of the Test button during each mode of operation.

TABLE 12. Test Button Function

Mode of Operation	Press the Test Button to...
Normal	Trigger a leak detection response. Verify all equipment is wired correctly into the RDSC (after installation).
Leak Detected	Reset the RDSC to a normal mode of operation after a previous leak has been detected and purged from the HVAC system.
Fault	Reset the RDSC after troubleshooting and resolving a fault condition. If the fault is not resolved, the RDSC will enter the Fault mode again.

Test Button - Additional Functions

Table 13 lists the additional functions of the Test Button while the RDS Non-Communicating Blower Control Board is functioning within the states of Initializing, Monitoring, Leak Detection, Servicing and Fault. Refer to "Table 10. LED Diagnostic Codes".

TABLE 13. Additional Button Functions

State	Press	Action
Initializing	Short	Skips remaining pre-purge after sensors are recognized by the RDSC
Initializing	Long	Reset control
Monitoring	Short	Clear purge-counter if prior mitigation has occurred; Test mitigation
Monitoring	Long	Reset control
Mitigating	Short	If testing mitigation, end test
Servicing	Short	Reevaluate fault condition - if cleared return to monitoring, otherwise update indicator
Servicing	Long	Reset control
Fault	Short	Reevaluate fault condition - if cleared return to monitoring, otherwise update indicator
Fault	Long	Reset control

Thermostat Compatibility

Thermostats that preserve memory settings are compatible with the RDS Non-Communicating Blower Control Board. Examples include:

- Battery-powered thermostats
- Analog thermostats
- Smart thermostats
- Late-model programmable thermostats
- *Early-generation digital and programmable thermostats may not retain the operation mode and temperature setpoints after a power outage.*

The following scenarios are likely to occur when home occupants are not available to adjust the thermostat setpoints as the system is recovering from leak detection and resuming normal operation:

- Heating could be lost during a cold night
- Cooling could be lost during a hot day
- The thermostat could reset to an incorrect temperature setpoint

Compatibility Verification

Complete the following process to determine whether the thermostat is compatible with the RDS Non-Communicating Blower Control Board.

- 1 - Change the thermostat's current setpoint and operating mode.
- 2 - Power cycle the breaker to the furnace.

NOTE – Wait five (5) minutes before supplying power to the furnace breaker.

- 3 - Note whether the thermostat maintained its setpoints and operating mode.
 - a. If the thermostat maintained the settings, the thermostat is compatible with the RDS Non-Communicating Blower Control Board.
 - b. If the thermostat did not maintain its setpoint and/or operating mode, the thermostat is not compatible with the RDS Non-Communicating Blower Control Board. Recommend replacing with a compatible thermostat.

Additional Applications

In zoned applications, all dampers will remain open when the RDS Non-Communicating Blower Control Board is in Fault or Leak Detected mode. Normal heating and cooling demands are permissible, but the blower will remain engaged until the fault condition is addressed.

Zone HVAC System

If the RDS Non-Communicating Blower Control Board is installed in a zone HVAC system, the RDS Non-Communicating Blower Control Board will open all zone dampers if a leak is detected.

NOTE – Proper wiring of the zone panel to the RDS Non-Communicating Blower Control Board is required for all zone dampers to open.

After the purge sequence is complete, the zone system will resume normal operation.

External Alarm

(For applications with external alarms wired directly to the RDS Non-Communicating Blower Control Board.)

The RDS Non-Communicating Blower Control Board triggers the external alarm system when it enters Leak Detected mode. For alarm notifications, the RDS Non-Communicating Blower Control Board provides a dry relay contact that is rated 3A at 30 VAC/DC.

Start Up Test Procedure

The RDS Non-Communicating Blower Control Board is equipped with a Test/Reset button, see "Test Button Functionality" on page 19. After the RDS Non-Communicating Blower Control Board has been mounted and wired, restore power to the HVAC system. The system will then run through a purge sequence for five (5) minutes. After the purge sequence is complete, proceed to testing cooling demand and heating demand.

Cooling Demand

- 1 - Prompt a cooling demand at the thermostat.
- 2 - Press the Test button on the RDS Non-Communicating Blower Control Board.

The system then executes a leak detection response.
- 3 - Observe the following sequence:
 - a. The LED indicator flashes the sequence for leak detection (flashing blue).
 - b. The blower powers up.
 - c. The compressor powers down.
- 4 - Press the Test button to terminate the simulated Leak Detected mode upon test completion.

Heating Demand

- 1 - Prompt a heating demand at the thermostat.
- 2 - Press the Test button on the RDS Non-Communicating Blower Control Board.

The system then executes a leak detection response.
- 3 - Observe the following sequence:
 - a. The LED indicator flashes the sequence for leak detection (flashing blue).
 - b. The blower powers up.
 - c. The gas burners power down.
 - d. The compressor powers down.
- 4 - Press the Test button to terminate the simulated Leak Detected mode upon test completion.

The installation of the RDS Non-Communicating Blower Control Board is complete after both sequences are successfully completed.

NOTE – REFRIGERANT SENSORS for REFRIGERANT DETECTION SYSTEMS shall only be replaced with sensors specified by the appliance manufacture.

Diagnostic Codes and Troubleshooting

TABLE 14. LED Diagnostic Codes

State	LED Diagnostic Code	Action Required
Initializing	Flashing green	None
Monitoring	Solid green. If a prior mitigation occurred, a blue flash interrupts the solid green LED.	None
Mitigating (Leak Detected)	Flashing blue	Check coil tubes for leak. Repair the issue and restart the equipment.
Fault/Service	Solid blue, interrupted by issue diagnostic code	Refer to Table 15 for troubleshooting steps.

TABLE 15. Red LED Diagnostic Codes / Troubleshooting

Red Flash	Applies to Individual Sensor(s)	Issue	Action Required
1	Yes	Sensor indicates fault	Replace the sensor
2	No	Spare Code - Unused	Not Applicable
3	Yes	Incompatible sensor type	Replace the sensor
4	Yes	Sensor communications issue	Check sensor connection. Ensure connection is clean and tight.
5	No	R-input not available	Check sensor connections. Ensure connection is clean and tight.
6	No	Invalid configuration of sensor count	Verify the DIP switch setting is correct and matches the number of sensors being used.

Wiring Diagrams

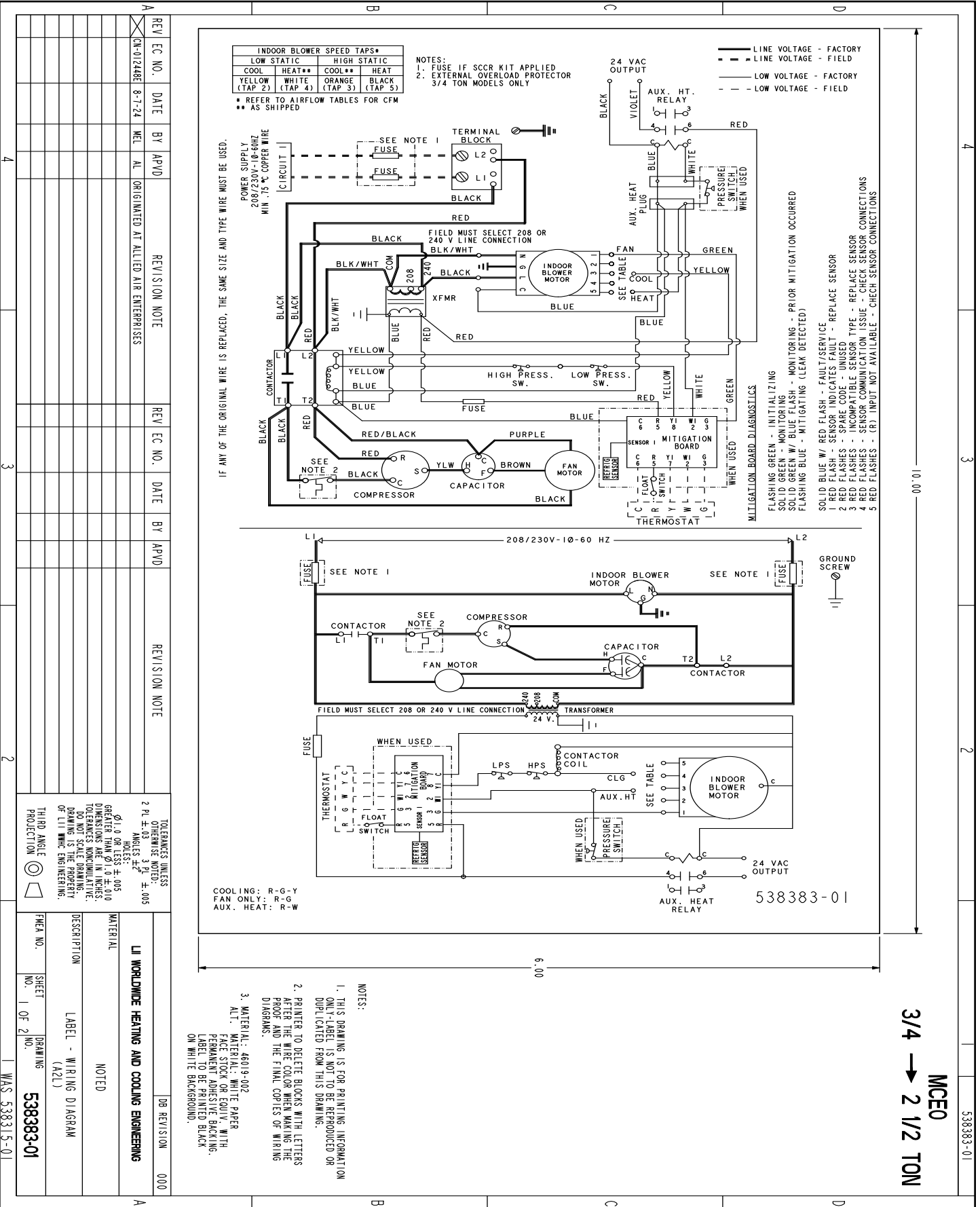

208/230V-10-60 HZ

SEE NOTE 1

INDOOR BLOWER MOTOR

SEE NOTE 1

GROUND SCREW

CONTACTOR

COMPRESSOR

FAN MOTOR

CAPACITOR

FIELD MUST SELECT 208 OR 240 V LINE CONNECTION

TRANSFORMER

24 VAC OUTPUT

AUX. HEAT RELAY

538383-01

NOTES:

1. THIS DRAWING IS FOR PRINTING INFORMATION ONLY. LABEL IS NOT TO BE REPRODUCED OR DUPLICATED FROM THIS DRAWING.
2. PRINTER TO DELETE BLOCKS WITH LETTERS AFTER THE WIRE COLOR WHEN MAKING THE PROOF AND THE FINAL COPIES OF WIRING DIAGRAMS.
3. MATERIAL: 46019-002
ALT. MATERIAL: WHITE PAPER
FACE STOCK OR EQUIV. WITH PERMANENT ADHESIVE BACKING.
LABEL TO BE PRINTED BLACK ON WHITE BACKGROUND.

3. MATERIAL: 46019-002
ALT. MATERIAL: WHITE PAPER
FACE STOCK OR EQUIV. WITH PERMANENT ADHESIVE BACKING.
LABEL TO BE PRINTED BLACK ON WHITE BACKGROUND.

THIRD ANGLE PROJECTION

2 PL ±.005 DIMENSIONS UNLESS OTHERWISE NOTED.
ANGLES ±.4°
HOLEES:
Ø 1.0 OR LESS ±.005
GREATER THAN Ø 1.0 ±.010
DIMENSIONS ARE IN INCHES.
TOLERANCES INDICATED:
DRAWING IS THE PROPERTY
OF LIT. WHICH ENGINEERING.

DESCRIPTION: LABEL - WIRING DIAGRAM (A2L)

FINA NO. SHEET NO. 1 OF 2 NO. 538383-01

OB REVISION 000

LI WORLDWIDE HEATING AND COOLING ENGINEERING

NOTED

538383-01

MAS 538315-01

538383-01

MCE0

3/4 → 2 1/2 TON

Figure 12. Wiring Diagram - MCE without Electric Heat (0.75 Ton through 2.5 Ton)

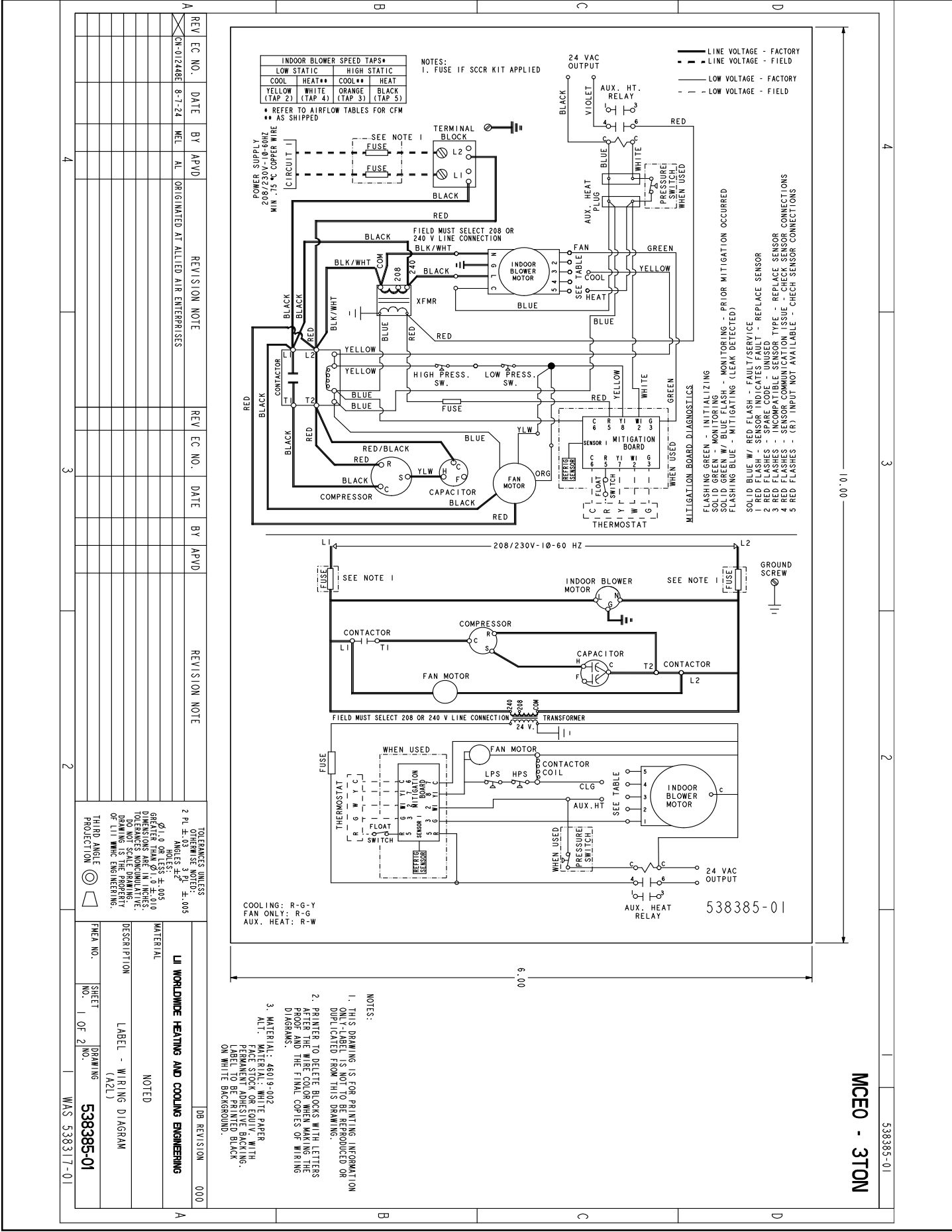

Figure 14. Wiring Diagram - MCEO without Electric Heat (3 Ton)

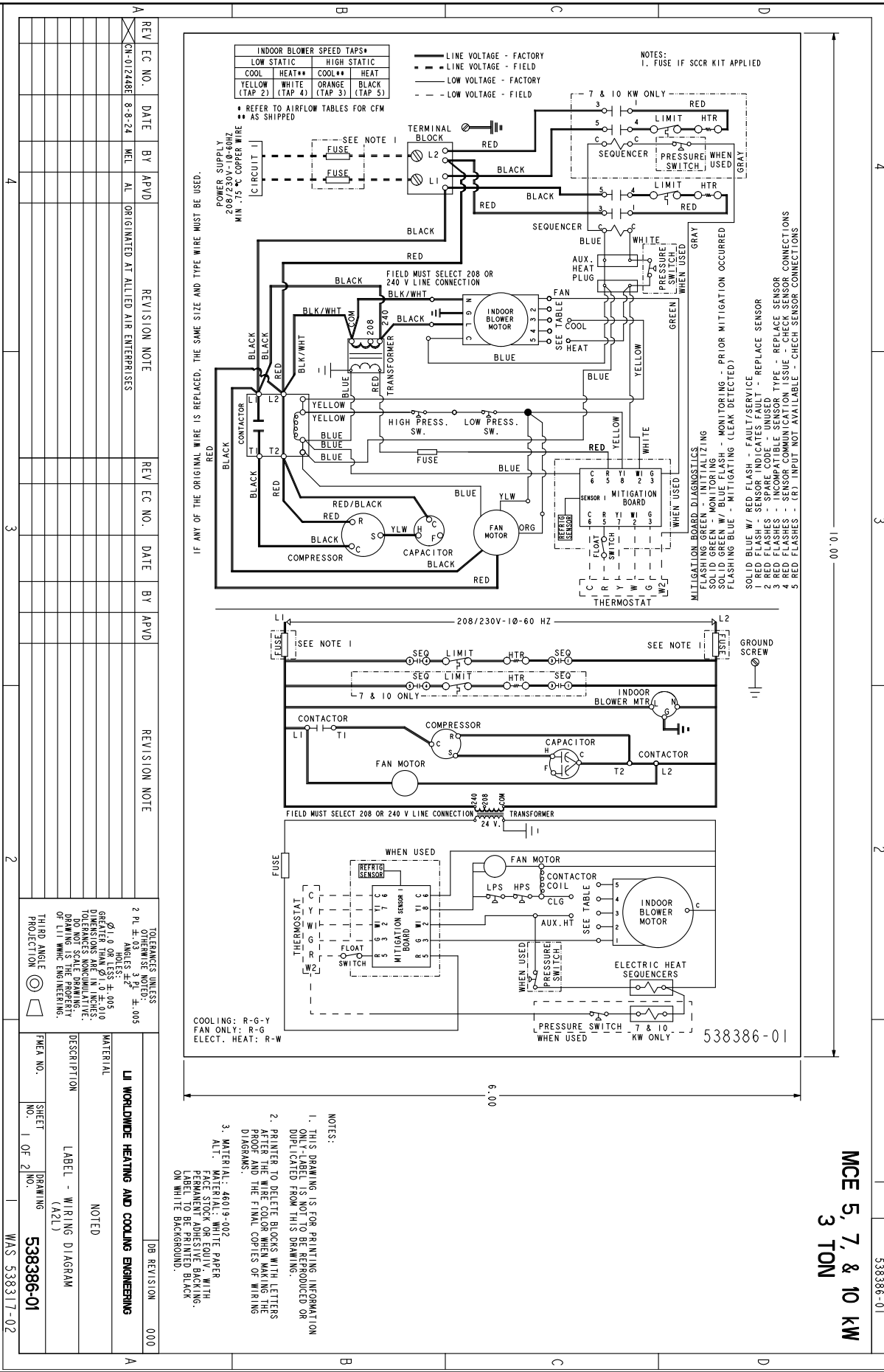

Figure 15. Wiring Diagram - MCE with Factory-Installed Electric Heat (3 Ton)

Decommissioning

Before carrying out this procedure, it is essential that the technician is completely familiar with the equipment and all its detail. It is recommended good practice that all refrigerants are recovered safely.

Prior to the task being carried out, an oil and refrigerant sample shall be taken in case analysis is required prior to re-use of recovered refrigerant. It is essential that electrical power is available before starting decommissioning.

- a) Become familiar with the equipment and its operation.
- b) Isolate system electrically.
- c) Before attempting the procedure, ensure that:
 - mechanical handling equipment is available, if required, for handling refrigerant cylinders;
 - all personal protective equipment is available and being used correctly;
 - the recovery process is supervised at all times by a competent person;
 - recovery equipment and cylinders conform to the appropriate standards.
- d) Pump down refrigerant system, if possible.
- e) If a vacuum is not possible, make a manifold so that refrigerant can be removed from various parts of the system.
- f) Make sure that cylinder is situated on the scales before recovery takes place.
- g) Start the recovery machine and operate in accordance with instructions.
- h) Do not overfill cylinders (no more than 80% volume liquid charge).
- i) Do not exceed the maximum working pressure of the cylinder, even temporarily.
- j) When the cylinders have been filled correctly and the process completed, make sure that the cylinders and the equipment are removed from site promptly and all isolation valves on the equipment are closed off.
- k) Recovered refrigerant shall not be charged into another REFRIGERATING SYSTEM unless it has been cleaned and checked.

NOTE – Equipment shall be labelled stating that it has been decommissioned and emptied of refrigerant. The label shall be dated and signed. For appliances containing FLAMMABLE REFRIGERANTS, ensure that there are labels on the equipment stating the equipment contains FLAMMABLE REFRIGERANT.

Recovery

When removing refrigerant from a system, either for servicing or decommissioning, it is recommended good practice that all refrigerants are removed safely:

- When transferring refrigerant into cylinders, ensure that only appropriate refrigerant recovery cylinders are employed.
- Ensure that the correct number of cylinders for holding the total system charge is available.
- All cylinders to be used are designated for the recovered refrigerant and labelled for that refrigerant (i. e. special cylinders for the recovery of refrigerant).
- Cylinders shall be complete with pressure-relief valve and associated shut-off valves in good working order.
- Empty recovery cylinders are evacuated and, if possible, cooled before recovery occurs.
- The recovery equipment shall be in good working order with a set of instructions concerning the equipment that is at hand and shall be suitable for the recovery of the flammable refrigerant.
- If in doubt, the manufacturer should be consulted. In addition, a set of calibrated weighing scales shall be available and in good working order. Hoses shall be complete with leak-free disconnect couplings and in good condition.
- The recovered refrigerant shall be processed according to local legislation in the correct recovery cylinder, and the relevant waste transfer note arranged. Do not mix refrigerants in recovery units and especially not in cylinders.
- If compressors or compressor oils are to be removed, ensure that they have been evacuated to an acceptable level to make certain that flammable refrigerant does not remain within the lubricant.
- The compressor body shall not be heated by an open flame or other ignition sources to accelerate this process. When oil is drained from a system, it shall be carried out safely.