



## INSTALLATION INSTRUCTIONS

# ATSLEEVE1-1

Transition Sleeve Kit for Retrofit Installation of  
MHP12(24,30), MCE12(30), MHP11(24,30), MCE11(30) Models  
with ASLEEVE\*-1

This manual must be left with the homeowner for future reference.



This is a safety alert symbol and should never be ignored. When you see this symbol on labels or in manuals, be alert to the potential for personal injury or death.

### Shipping and Packing List

Package 1 of 1 contains:

- 1 - Right Side Panel
- 1 - Left Side Panel
- 1 - Top Panel
- 1 - Divider Panel
- 12 - #10 x 1/2" screws
- 10 - #10 x 1-1/2" self-tapping screws
- 1 - Installation Instruction

Check the Kit for shipping damage. If you find any damage, immediately contact the last carrier.

Manufactured By  
**Allied Air Enterprises LLC**  
A Lennox International, Inc. Company  
215 Metropolitan Drive  
West Columbia, SC 29170



(P) 508042-01

### Installation

1. Place top panel on flat surface as shown in Figure 1.

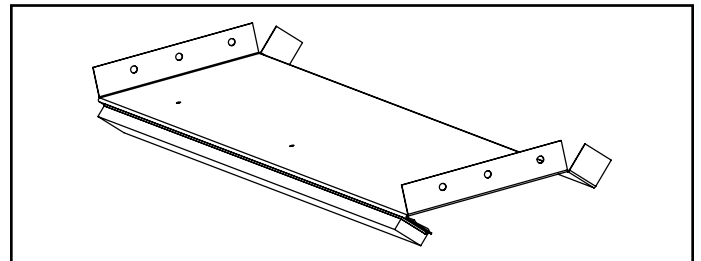

Figure 1.

2. Using 3 #10 x 1/2" screws, attach right side panel to top panel. See Figure 2.

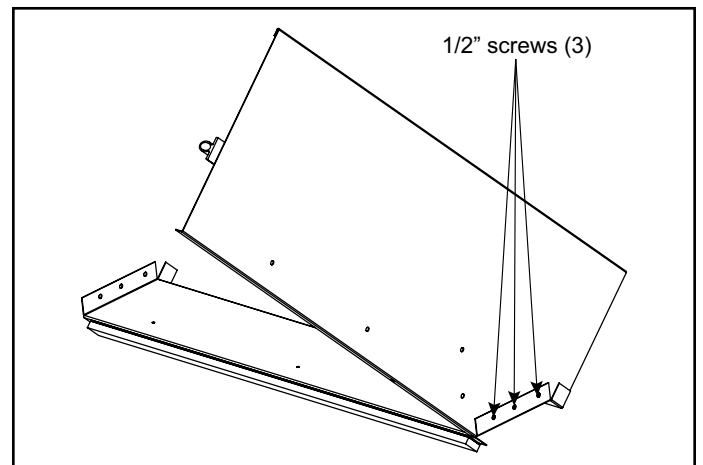
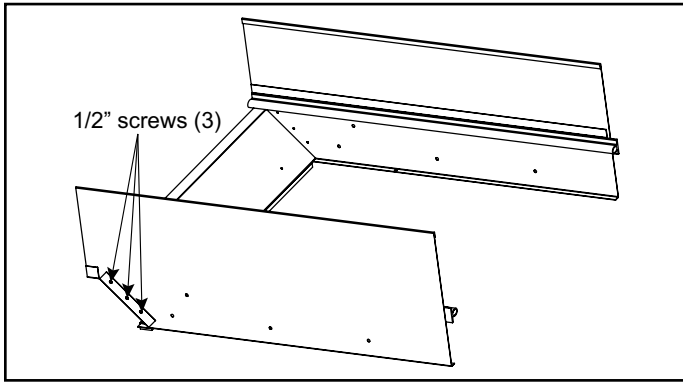

Figure 2.

3. Using 3 #10 x 1/2" screws, attach left side panel to top panel. See Figure 3.



**Figure 3.**

4. Turn assembly over and place divider panel between the side panels (between end flange and center gasket). Using 4 #10 x 1/2" screws, secure divider panel to side panels. See Figure 4.

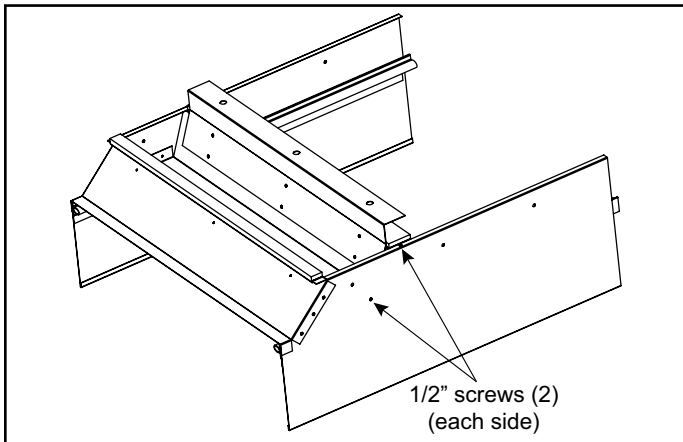

**Figure 4.**

5. Lift transition sleeve assembly into the upright position and hang the assembly onto the vertical flange of the wall sleeve divider panel. See Figure 5.

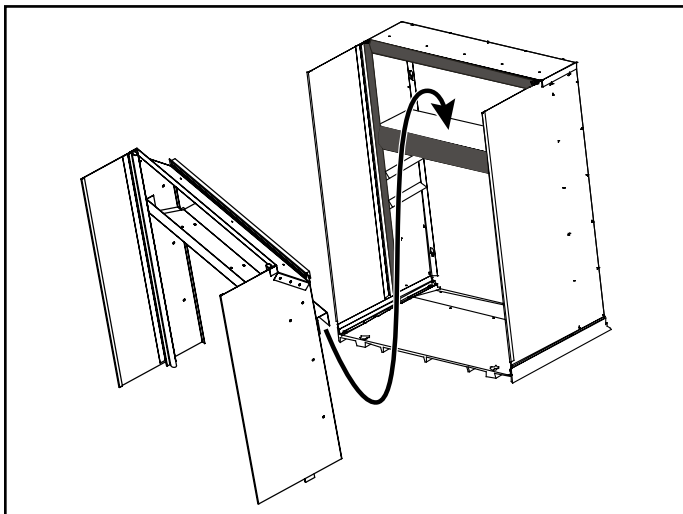

**Figure 5.**

6. Using 3 #10 x 1-1/2" self-tapping screws, secure transition sleeve assembly panel to wall sleeve divider panel. See Figure 6.

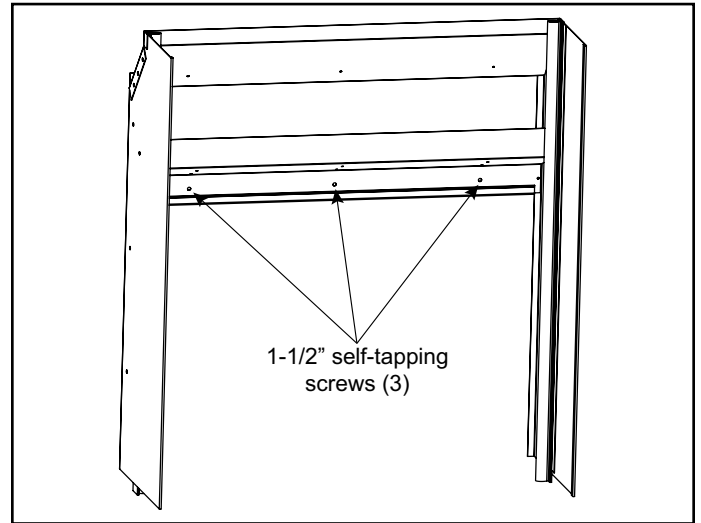

**Figure 6.**

7. Using 6 #10 x 1-1/2" self-tapping screws, secure side panels of transition sleeve assembly to the side panels of the wall sleeve. See Figure 7.

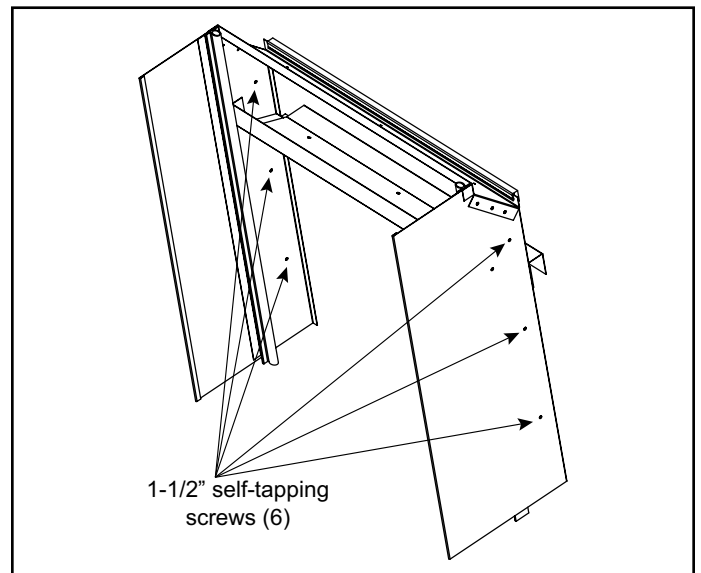

**Figure 7.**