

# RPCE13

## PRODUCT SPECIFICATIONS

13 SEER ELECTRIC / ELECTRIC  
RESIDENTIAL PACKAGED UNIT

FORM NO. RPCE13-100 (06/2014)

### REFRIGERANT SYSTEM

- Environmentally friendly R410A refrigerant
- Copper tubing with enhanced fin coils
- External service gauge ports

### CABINET CONSTRUCTION

- Low profile, with compact footprint
- Insulation to minimize heat loss plus reduce sound
- Baked on pre-painted steel cabinet finish
- Easy service access
- Wire grill protection
- One piece "no leak" top design

### BLOWER

- Insulated compartment to reduce sound
- High efficiency multispeed motor for wide airflow range

### INSTALLATION

- Full perimeter base rail system for easy installation
- Horizontal or down discharge, duct covers provided
- Utility connections on "right side"
- Filter channels for 1" filter field provided

### WARRANTY

10 year limited parts and compressor warranty/lifetime heat exchanger warranty available. See limited warranty document for details.



### Model Number Guide

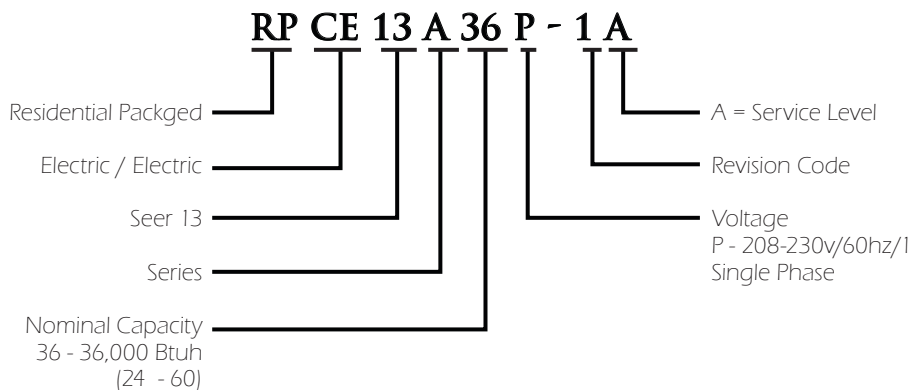

### Electrical and Physical Data

Model	Voltage/HZ/ Phase	Voltage Range 60 hz	Minimum Circuit Amp.	Maximum Over Current Device (amps)	Compressor		Condenser Fan Motor			Indoor Blower Motor		Refrig. Charge	Weight (lbs.)
					Rated Load (amps)	Locked Rotor (amps)	Rated Load (amps)	Rated HP	Nom. RPM	Rated Load (amps)	Rated HP		
RPCE13A24P	208-230/60/1	197-253	15.7	20	8.3	43	1.2	1/4	1075	4.1	1/2	82	345
RPCE13A30P	208-230/60/1	197-253	19.3	25	11.2	54	1.2	1/4	1075	4.1	1/2	82	350
RPCE13A36P	208-230/60/1	197-253	22.9	30	14.1	77	1.2	1/4	1075	4.1	1/2	122	360
RPCE13A42P	208-230/60/1	197-253	27.5	40	16.2	88	1.7	1/3	1075	5.8	3/4	90	435
RPCE13A48P	208-230/60/1	197-253	28.4	40	16.7	84	1.7	1/3	1075	5.8	3/4	96	455
RPCE13A60P	208-230/60/1	197-253	38.7	60	25.0	134	1.7	1/3	1075	5.8	3/4	140	465

### Performance

Model	Cooling				
	SEER	EER	Rated AHRI Capacity <sup>1</sup> BTUH	Rated Sensible Capacity BTUH	CFM
RPCE13A24P	13.0	11.0	22,800	16,000	800
RPCE13A30P	13.0	11.0	28,000	21,000	1000
RPCE13A36P	13.0	11.0	34,000	24,100	1200
RPCE13A42P	13.0	11.0	40,000	30,000	1400
RPCE13A48P	13.0	11.0	46,000	34,500	1600
RPCE13A60P	13.0	11.0	56,000	40,300	1800

## Blower Performance

Model	Blower Tap							
		0.2	0.3	0.4	0.5	0.6	0.7	0.8
RPCE13A24P	1	600	400	310	---	---	---	---
	2	780	740	710	630	590	560	500
	3	900	870	830	800	730	690	640
	4	900	870	830	800	730	690	640
	5	1060	1030	980	960	930	910	860
RPCE13A30P	1	650	550	490	430	---	---	---
	2	1030	1000	970	930	900	860	820
	3	1150	1110	1080	1050	1010	980	960
	4	1110	1070	1040	1000	970	950	920
	5	1150	1110	1080	1050	1010	980	960
RPCE13A36P	1	650	590	500	430	---	---	---
	2	1240	1200	1150	1100	1060	1020	980
	3	1320	1260	1230	1200	1160	1120	1080
	4	1240	1200	1150	1100	1060	1020	980
	5	1320	1260	1230	1200	1160	1120	1080
RPCE13A42P	1	780	690	610	540	---	---	---
	2	1450	1370	1280	1200	1120	1060	990
	3	1650	1570	1510	1440	1360	1260	1160
	4	1510	1430	1380	1290	1220	1150	1090
	5	1650	1570	1510	1440	1360	1260	1160
RPCE13A48P	1	860	760	690	640	---	---	---
	2	1650	1600	1550	1500	1440	1370	1290
	3	1800	1750	1690	1630	1570	1470	1330
	4	1650	1600	1550	1500	1440	1370	1290
	5	1800	1750	1690	1630	1570	1470	1330
RPCE13A60P	1	1000	900	800	750	---	---	---
	2	1820	1790	1730	1670	1630	1530	1380
	3	1950	1910	1860	1800	1700	1560	1360
	4	1820	1790	1730	1670	1630	1530	1380
	5	1950	1910	1860	1800	1700	1560	1360

Subtract .10 Duct Static for Downflow CFM

Taps 4 &amp; 5 are used with Electric Heat. Refer to Heater Label on unit for proper Heat Tap selection

## Cooling Performance Extended Ratings

Model	Indoor Temp DB/WB °F	Outdoor Temp - DB°F														
		65°			82°			95°			105°			115°		
		Btuh	S/T	kW	Btuh	S/T	kW	Btuh	S/T	kW	Btuh	S/T	kW	Btuh	S/T	kW
RPCE13A24P	85/72	27,800	0.59	1.66	25,900	0.61	1.90	24,400	0.63	2.09	22,800	0.67	2.23	21,600	0.71	2.24
	80/67	26,400	0.65	1.65	24,900	0.68	1.89	22,800	0.71	2.07	21,600	0.75	2.19	17,700	0.82	2.18
	75/63	25,100	0.69	1.64	22,500	0.71	1.87	20,500	0.73	2.04	18,100	0.81	2.15	15,000	0.88	2.14
	75/57	23,000	1.00	1.62	21,500	1.00	1.85	20,300	1.00	2.03	18,400	1.00	2.15	15,400	1.00	2.14
RPCE13A30P	85/72	36,100	0.60	2.04	33,200	0.63	2.35	31,100	0.65	2.58	28,200	0.68	2.74	25,300	0.71	2.79
	80/67	34,100	0.67	2.02	31,200	0.71	2.33	28,000	0.74	2.55	25,100	0.80	2.66	21,700	0.82	2.73
	75/63	32,400	0.70	2.01	28,200	0.75	2.29	25,000	0.79	2.51	22,000	0.84	2.65	18,900	0.89	2.68
	75/57	29,700	1.00	1.98	26,900	1.00	2.27	24,900	1.00	2.50	22,100	1.00	2.64	19,300	1.00	2.68
RPCE13A36P	85/72	39,000	0.62	2.35	37,500	0.64	2.77	36,300	0.65	3.10	34,200	0.68	3.43	31,900	0.70	3.48
	80/67	36,800	0.69	2.34	36,100	0.71	2.73	34,000	0.72	3.09	31,000	0.76	3.33	29,000	0.78	3.47
	75/63	35,600	0.72	2.33	32,900	0.75	2.74	30,700	0.77	3.06	28,500	0.80	3.38	26,100	0.83	3.44
	75/57	32,000	1.00	2.29	31,000	1.00	2.71	30,300	1.00	3.03	28,100	1.00	3.35	25,800	1.00	3.40

### Heat Strip Electrical

Model No.	Heater Model	Unit Supply Single Phase	Heater kW	Minimum Circuit Ampacity 1	Maximum Fuse / HACR Brkr. 2 1	Minimum Circuit Ampacity 2	Maximum Fuse / HACR Brkr. 2 2
RPCE13A24P RPCE13A30P RPCE13A36P	AHS05A	240	5.0	31.2	35	----	---
		208	3.7	27.8	30	----	---
	AHS07A	240	7.0	41.7	50	----	---
		208	5.3	36.8	40	----	---
	AHS010A	240	10.0	57.3	60	----	---
		208	7.5	50.3	60	----	---
AHS015A	240	15.0	57.3	60	26	30	
	208	11.3	50.3	60	22.5	25	
RPCE13A42P RPCE13A48P RPCE13A60P	AHS05A	240	5.0	33.3	35	----	---
		208	3.7	29.9	30	----	---
	AHS07A	240	7.0	43.8	50	----	---
		208	5.3	38.9	40	----	---
	AHS010A	240	10.0	59.4	60	----	---
		208	7.5	52.4	60	----	---
	AHS015A	240	15.0	59.4	60	26	30
		208	11.3	52.4	60	22.5	25
	AHS020A	240	20.0	59.4	60	52.1	60
		208	15.0	52.4	60	45.1	50

### Field Provided 1" Filter Dimensions

Small Base	2, 2.5, 3 Ton	24" width 28" height
Large Base	3.5, 4, 5 Ton	30" width 30" height

### Accessories

Description	Where Used	Kit Number
5 kW Electric Heater	All Models	AHS05A-1
7 kW Electric Heater	All Models	AHS07A-1
10 kW Electric Heater	All Models	AHS010A-1
15 kW Electric Heater	All Models	AHS015A-1
20 kW Electric Heater	42, 48 & 60	AHS020A-1
Roof Curbs	24, 30 & 36	ACURB160-1
Roof Curbs	42, 48 & 60	ACURB162-1
Manual Fresh Air Damper	24,30,36	ADMPR145-1
Manual Fresh Air Damper	42,48,60	ADMPR166-1
Motorized Fresh Air Damper	24,30,36	ADMPR146-1
Motorized Fresh Air Damper	42,48,60	ADMPR167-1
Downflow Economizer	24,30,36	AECON825-1
Downflow Economizer	42,48,60	AECON826-1
Horizontal Economizer	24,30,36	AECON827-1
Horizontal Economizer	42,48,60	AECON828-1

### Sound Ratings

Model No.	Sound dBA
RPCE13A24P	78
RPCE13A30P	79
RPCE13A36P	79
RPCE13A42P	80
RPCE13A48P	80
RPCE13A60P	80

Dimensions (in.)

Model No.	A	B	C	D	E	F
RPCE13-24	32-1/2	46-1/2	46-1/2	45-5/8	45-5/8	17-1/2
RPCE13-30						
RPCE13-36						
RPCE13-42	34-1/2	55-1/2	50-1/2	54-5/8	49-5/8	21-1/2
RPCE13-48						
RPCE13-60						

Model No.	G	H	J	K	L
RPCE13-24	11-1/2	5-1/2	1-5/8	4	4
RPCE13-30					
RPCE13-36					
RPCE13-42	12	5-1/2	1-5/8	6-1/4	5-5/8
RPCE13-48					
RPCE13-60					

Model No.	M	N	P	Q	R
RPCE13-24	1-3/4	15-5/8	27-3/4	24-7/8	9-3/4
RPCE13-30					
RPCE13-36					
RPCE13-42	2-3/8	17-1/8	29-3/4	26-7/8	15-1/2
RPCE13-48					
RPCE13-60					

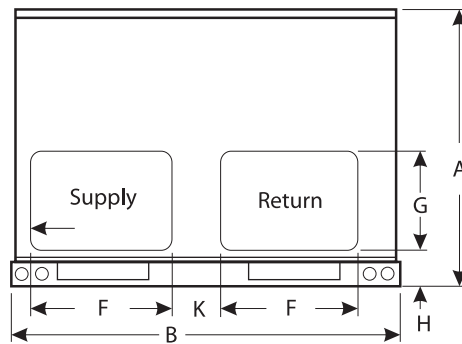

REAR

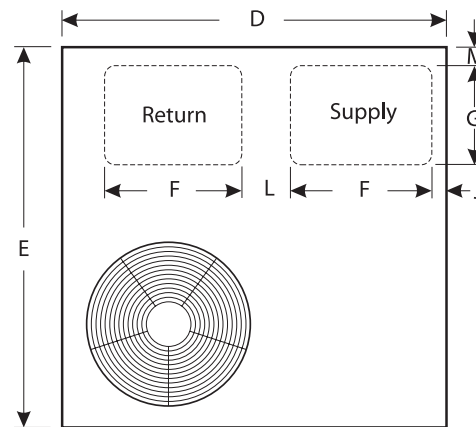

TOP

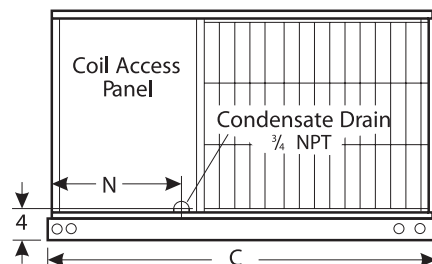

LEFT SIDE

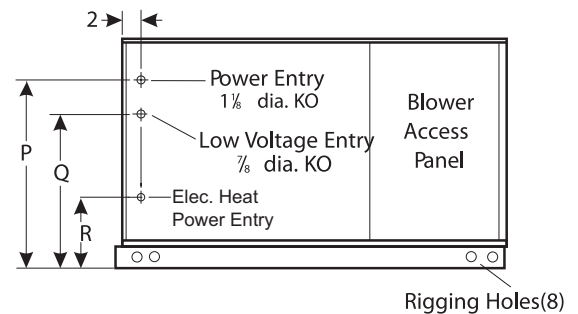

RIGHT SIDE

Accessories Dimensions inches (mm)

**ECONOMIZER DAMPERS - DOWNFLOW**

For 24, 30 and 36 Models

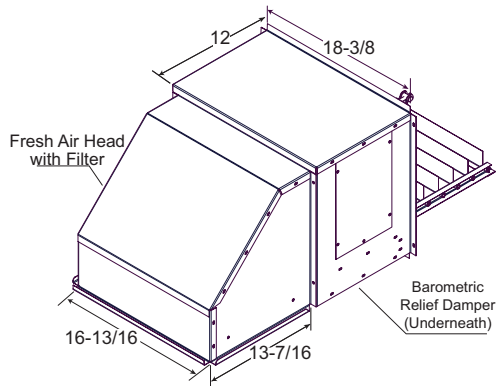

For 42, 48 and 60 Models

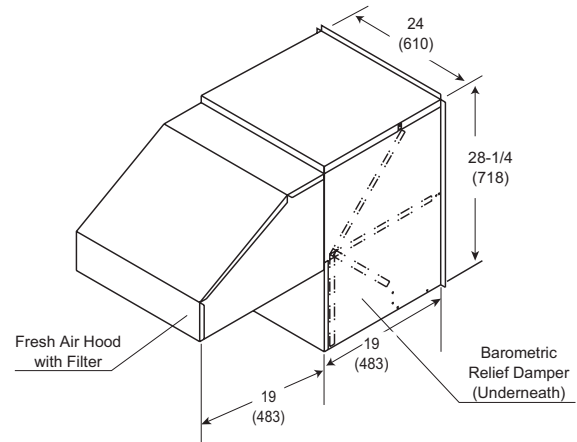

**ECONOMIZER DAMPERS - HORIZONTAL**

Model No.	A		B	
	in	mm	in	mm
RPCE13A 24, 30,36	17-5/8	448	11-1/2	292
RPCE13A 42, 48, 60	21-3/4	552	12-1/4	311

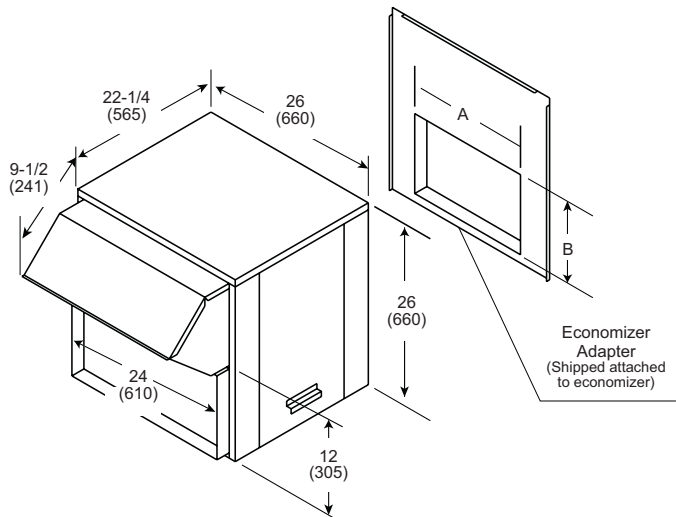

**FRESH AIR DAMPERS**

Manual

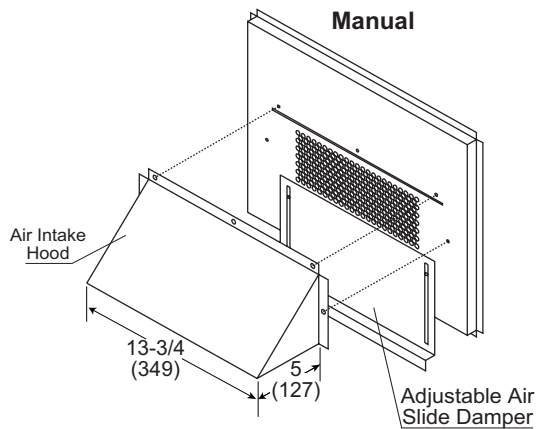

Motorized

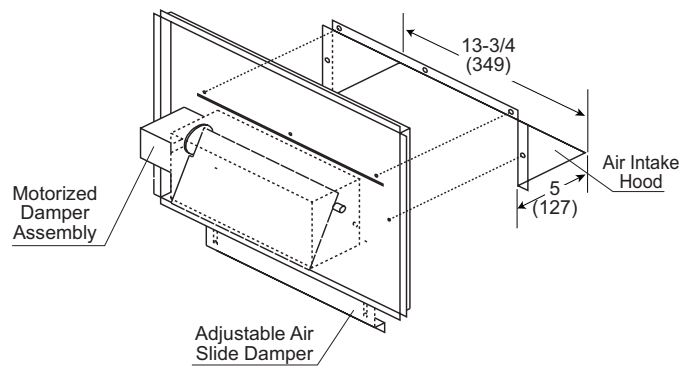

Accessories Dimensions inches (mm)

**ROOF CURB**

Dimensions inches (mm)

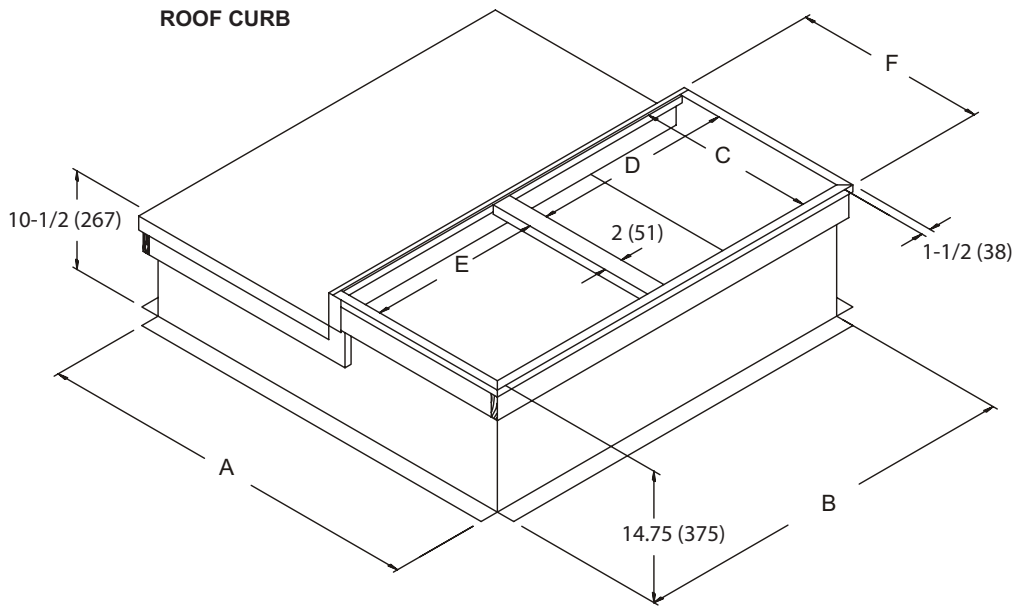

Model No.	A		B		C		D		E		F		G	
	in	mm	in	mm	in	mm	in	mm	in	mm	in	mm	in	mm
RPCE13A 24, 30, 36	43	1092	40	1016	43	1092	40	1016	18	457	20	508	19	483
RPCE13A 42, 48, 60	47-1/8	1197	44-1/8	1121	52	1321	49	1245	23-1/2	597	23-1/2	597	19-1/2	495

Revisions		
Section	Page #	Description
Performance	2	Rating tables revised



1-800-448-5872

All specifications and illustrations subject to change without notice and without incurring obligations.