



# INSTALLATION INSTRUCTIONS A98USMV

## Warm Air Gas Furnace Upflow/Horizontal Left/Right Air Discharge Direct Vent

This manual must be left with the homeowner for future reference.



This is a safety alert symbol and should never be ignored. When you see this symbol on labels or in manuals, be alert to the potential for personal injury or death.

### WARNING

Improper installation, adjustment, alteration, service or maintenance can cause property damage, personal injury or loss of life. Installation and service must be performed by a licensed professional installer (or equivalent), service agency or the gas supplier.

### NOTICE

A thermostat is not included and must be ordered separately.

- A Comfort Sync® thermostat must be used in communicating applications.
- In non-communicating applications, a traditional non-communication thermostat may be used.

In all cases, setup is critical to ensure proper system operation.

Field wiring for both communicating and non-communicating applications is illustrated in these instructions.

### Table of Contents

|  |    |
|--|----|
| Gas Furnace .....                        | 4  |
| Shipping and Packing List .....          | 4  |
| Safety Information .....                 | 4  |
| General.....                             | 6  |
| Installation .....                       | 6  |
| Filters.....                             | 10 |
| Duct System .....                        | 10 |
| Venting Practices.....                   | 12 |
| Gas Piping.....                          | 27 |
| Electrical .....                         | 30 |
| Blower Performance .....                 | 45 |
| Gas Valve Operation .....                | 50 |
| Unit Start-Up.....                       | 50 |
| Other Unit Adjustments.....              | 54 |
| Heating Sequence of Operation .....      | 55 |
| Service.....                             | 56 |
| Integrated Control Diagnostic Codes..... | 58 |
| Repair Parts List.....                   | 65 |

### CAUTION

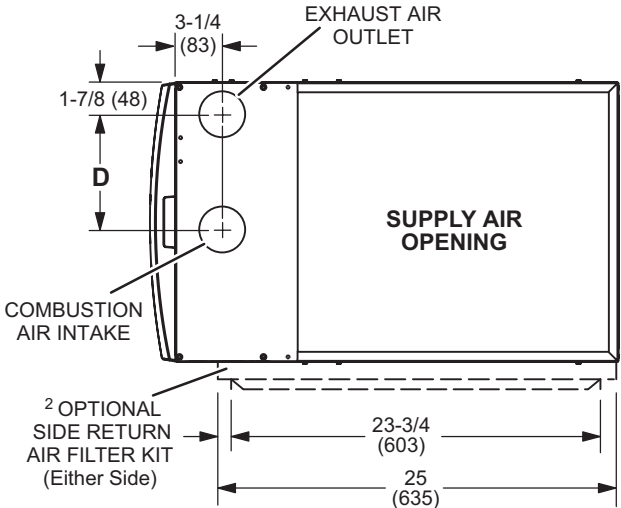
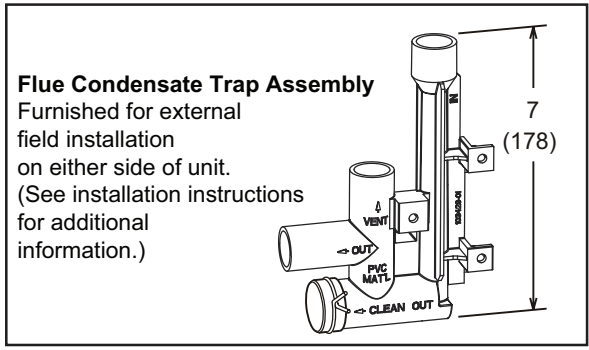
As with any mechanical equipment, personal injury can result from contact with sharp sheet metal edges. Be careful when you handle this equipment.

Manufactured By  
Allied Air Enterprises LLC  
A Lennox International, Inc. Company  
215 Metropolitan Drive  
West Columbia, SC 29170

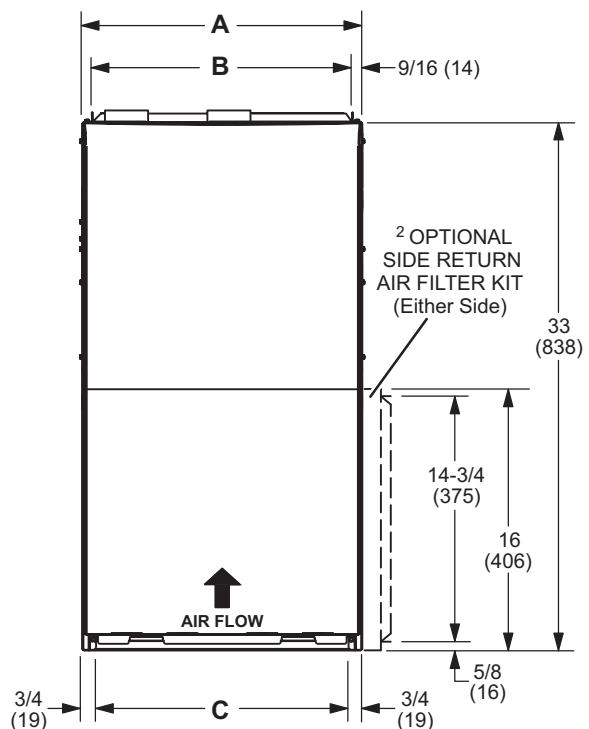


(P) 508364-01

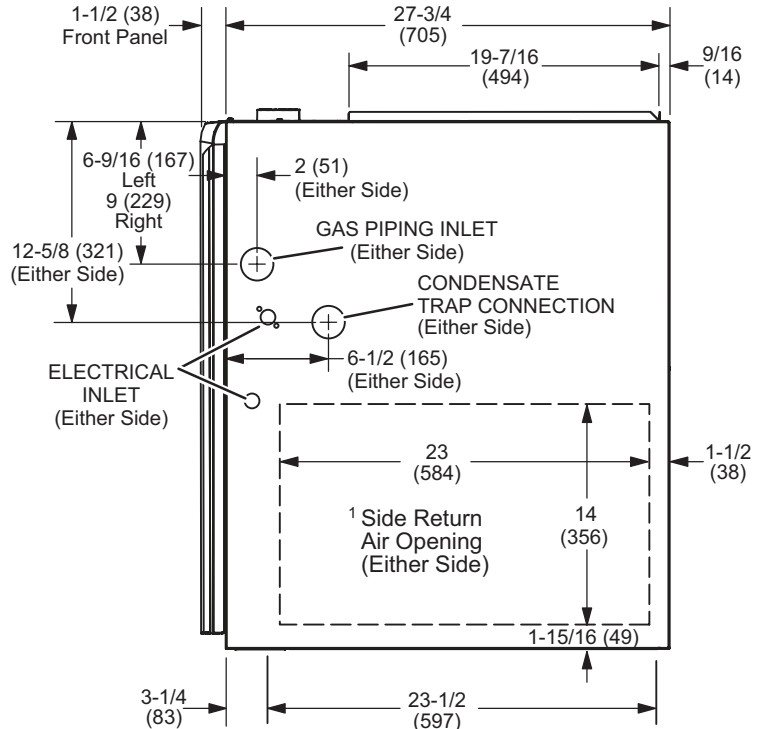
# Unit Dimensions



**TOP VIEW**



**FRONT VIEW**



**SIDE VIEW**

| Unit                                     | A      |     | B      |     | C      |     | D      |     |
|--|--------|-----|--------|-----|--------|-----|--------|-----|
|  | in.    | mm  | in.    | mm  | in.    | mm  | in.    | mm  |
| 070-B12                                  | 17-1/2 | 446 | 16-3/8 | 416 | 16     | 406 | 7-5/8  | 194 |
| 090-C12<br>090-C16<br>090-C20<br>110-C20 | 21     | 533 | 19-7/8 | 505 | 19-1/2 | 495 | 9-3/8  | 238 |
| 135-D20                                  | 24-1/2 | 622 | 23-3/8 | 594 | 23     | 584 | 11-1/8 | 283 |

# Parts Arrangement

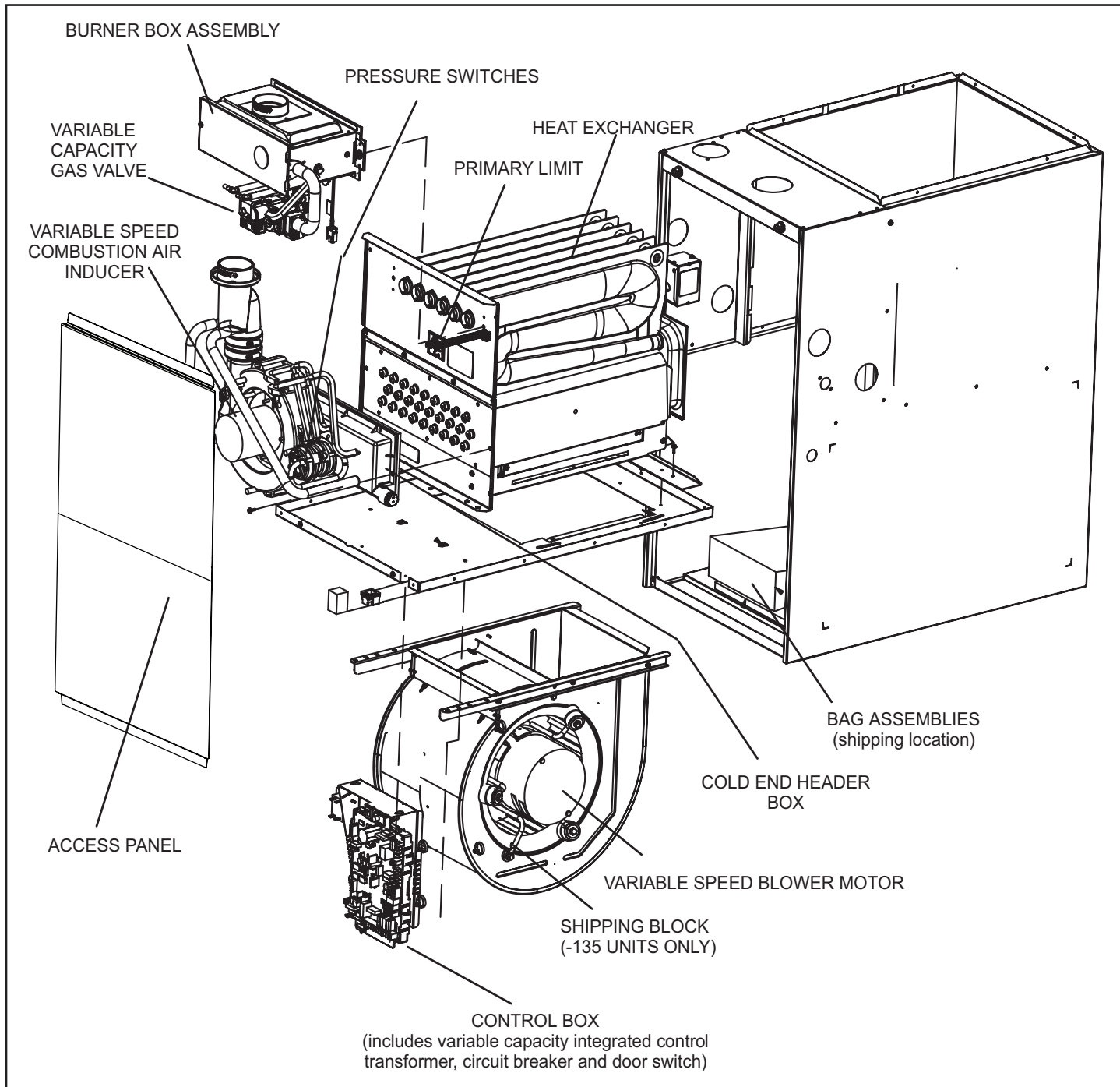


Figure 1.

## Gas Furnace

The A98USMV Category IV gas furnace is equipped with a variable capacity, variable speed integrated control. Each A98USMV is shipped ready for installation in the upflow, horizontal left air discharge or horizontal right air discharge position.

The furnace is equipped for installation in natural gas applications only. A change over kit must be ordered for LP/propane applications.

The A98USMV must be installed only as a Direct Vent gas central furnace

**NOTE:** *In Direct Vent installations, combustion air is taken from outdoors and flue gases are discharged outdoors. See Figure 2 for applications including roof termination.*

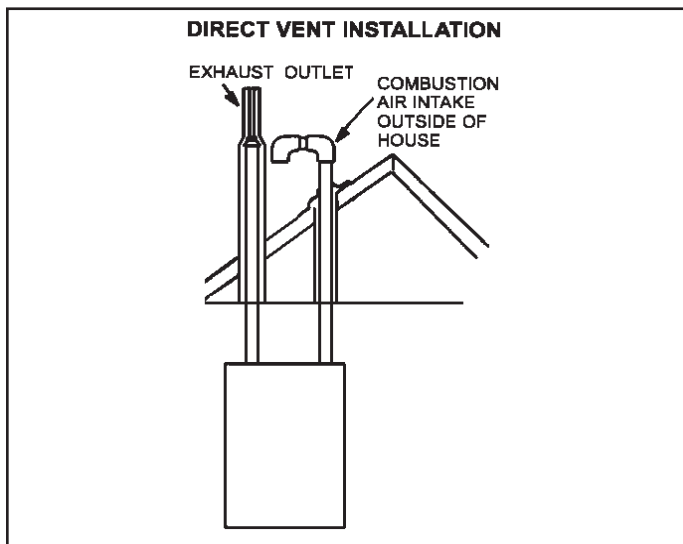


Figure 2.

## Shipping and Packing List

- 1 - Assembled A98USMV unit
- 1 - Bag assembly containing the following:
  - 1 - Snap bushing
  - 1 - Snap Plug
  - 1 - Wire tie
  - 1 - Condensate trap
  - 1 - Condensate trap cap
  - 1 - Condensate trap cap clamp
  - 1 - 3/4" Threaded PVC street elbow

Check equipment for shipping damage. If you find any damage, immediately contact the last carrier.

Please refer to specification sheets for available accessories.

## Safety Information

### **⚠ DANGER**

#### **DANGER OF EXPLOSION!**

There are circumstances in which odorant used with LP/Propane gas can lose its scent. In case of a leak, LP/Propane gas will settle close to the floor and may be difficult to smell. An LP/Propane leak detector should be installed in all LP applications.

### **⚠ WARNING**

Improper installation, adjustment, alteration, service or maintenance can cause property damage, personal injury or loss of life. Installation and service must be performed by a licensed professional installer (or equivalent), service agency or the gas supplier.

### **⚠ CAUTION**

As with any mechanical equipment, personal injury can result from contact with sharp sheet metal edges. Be careful when you handle this equipment.

Use only the type of gas approved for use with this furnace. Refer to unit nameplate.

### **Building Codes**

In the USA, installation of gas furnaces must conform with local building codes. In the absence of local codes, units must be installed according to the current National Fuel Gas Code (ANSI Z223.1/NFPA 54). The National Fuel Gas Code is available from the American National Standards Institute, Inc., 11 West 42nd Street, New York, NY 10036.

In Canada, installation must conform with current National Standard of Canada CSA-B149 Natural Gas and Propane Installation Codes, local plumbing or waste water codes and other applicable local codes.

### **Installed Locations**

The furnace is designed for installation clearances to combustible material as listed on the unit nameplate and in the tables in Figure 5 and Figure 11. Installers should also consider the greater of either accessibility/service clearances or fire protection clearances.

**NOTE:** *For installation on combustible floors, the furnace shall not be installed directly on carpeting, tile, or other combustible material other than wood flooring.*

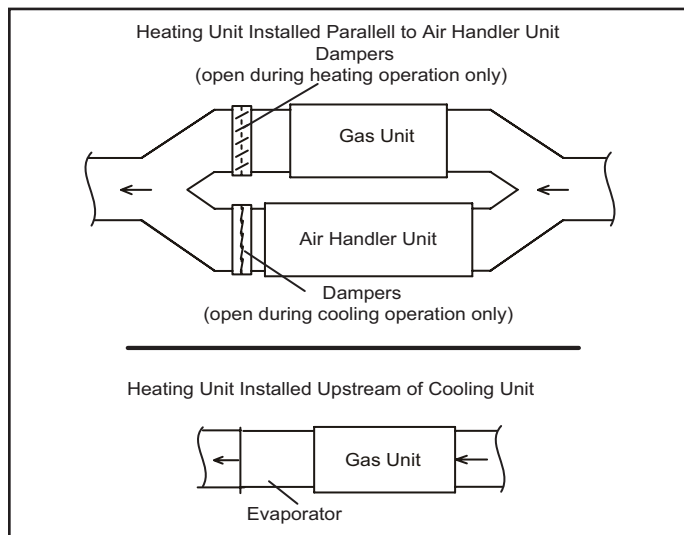
For installation in a residential garage, the furnace must be installed so that the burner(s) and the ignition source are located no less than 18 inches (457 mm) above the floor. The furnace must be located or protected to avoid physical damage by vehicles. When a furnace is installed in a public garage, hangar, or other building that has a hazardous atmosphere, the furnace must be installed according to recommended good practice requirements and current National Fuel Gas Code or CSA B149 standards.

**NOTE:** Furnace must be adjusted to obtain a temperature rise (100% percent capacity) within the range(s) specified on the unit nameplate. Failure to do so may cause erratic limit operation and may also result in premature heat exchanger failure.

This furnace must be installed so that its electrical components are protected from water.

### Installed in Combination with a Cooling Coil

When this furnace is used with cooling units, it shall be installed in parallel with, or on the upstream side of, cooling units to avoid condensation in the heating compartment. With a parallel flow arrangement, a damper (or other means to control the flow of air) must adequately prevent chilled air from entering the furnace. If the damper is manually operated, it must be equipped to prevent operation of either the heating or the cooling unit, unless it is in the full HEAT or COOL setting. See Figure 3.



**Figure 3. Heating Unit Installed Parallel to Air Handler Unit**

When installed, this furnace must be electrically grounded according to local codes. In addition, in the United States, installation must conform with the current National Electric Code, ANSI/NFPA No. 70. The National Electric Code (ANSI/NFPA No. 70) is available from the following address:

National Fire Protection Association  
1 Battery March Park  
Quincy, MA 02269

In Canada, all electrical wiring and grounding for the unit must be installed according to the current regulations of the Canadian Electrical Code Part I (CSA Standard C22.1) and/or local codes.

**NOTE:** This furnace is designed for a minimum continuous return air temperature of 60°F (16°C) or an intermittent operation down to 55°F (13°C) dry bulb for cases where a night setback thermostat is used. Return air temperature must not exceed 85°F (29°C) dry bulb.

The A98USMV furnace may be installed in alcoves, closets, attics, basements, garages, crawl spaces and utility rooms.

**This furnace design has not been CSA Certified for installation in mobile homes, recreational vehicles, or outdoors.**

### Use of Furnace as a Construction Heater

Units may be used for heating of buildings or structures under construction, if the following conditions are met to ensure proper operation.

**DO NOT USE THE UNIT FOR CONSTRUCTION HEAT UNLESS ALL OF THE FOLLOWING CRITERIA ARE MET:**

- a. Furnace must be in its final location. The vent system must be permanently installed per these installation instructions.
- b. Furnace must be installed as a two pipe system and one hundred percent (100%) outdoor air must be provided for combustion air requirements during construction.
- c. A room thermostat must control the furnace. The use of fixed jumpers that will provide continuous heating is prohibited.
- d. The input rate and temperature rise must be set per the furnace rating plate.
- e. Supply and Return air ducts must be provided and sealed to the furnace. Return air must be terminated outside of the space where furnace is installed.
- f. Return air temperature range between 60°F (16°C) and 80°F (27°C) must be maintained.
- g. MERV 11 or greater air filters must be installed in the system and must be regularly inspected and maintained (e.g., regular static checks and replaced at end of life) during construction.
- h. Blower and vestibule access panels must be in place on the furnace at all times.
- i. The furnace heat exchanger, components, duct system, and evaporator coils must be thoroughly cleaned following final construction clean-up.
- j. Air filters must be replaced upon construction completion.

- k. All furnace operating conditions (including ignition, input rate, temperature rise and venting) must be verified in accordance with these installation instructions.

EQUIPMENT MAY EXPERIENCE PREMATURE COMPONENT FAILURE AS A RESULT OF FAILURE TO FOLLOW THE ABOVE INSTALLATION INSTRUCTIONS. FAILURE TO FOLLOW THE ABOVE INSTALLATION INSTRUCTIONS VOIDS THE MANUFACTURER'S EQUIPMENT LIMITED WARRANTY. ALLIED AIR DISCLAIMS ALL LIABILITY IN CONNECTION WITH INSTALLER'S FAILURE TO FOLLOW THE ABOVE INSTALLATION INSTRUCTIONS.

NOTWITHSTANDING THE FOREGOING, INSTALLER IS RESPONSIBLE FOR CONFIRMING THAT THE USE OF CONSTRUCTION HEAT IS CONSISTENT WITH THE POLICIES AND CODES OF ALL REGULATING ENTITIES. ALL SUCH POLICIES AND CODES MUST BE ADHERED TO.

## General

These instructions are intended as a general guide and do not supersede local codes in any way. Consult authorities having jurisdiction before installation.

### CAUTION

These units should not be installed in areas normally subject to freezing temperatures.

In addition to the requirements outlined previously, the following general recommendations must be considered when installing one of these furnaces:

- Place the furnace as close to the center of the air distribution system as possible. The furnace should also be located close to the vent termination point.
- When the furnace is installed in non-direct vent applications, do not install the furnace where drafts might blow directly into it. This could cause improper combustion and unsafe operation.
- When the furnace is installed in non-direct vent applications, do not block the furnace combustion air opening with clothing, boxes, doors, etc. Air is needed for proper combustion and safe unit operation.
- When the furnace is installed in an attic or other insulated space, keep insulation away from the furnace.
- When the furnace is installed in an unconditioned space, consider provisions required to prevent freezing of condensate drain system.

**NOTE:** *The Commonwealth of Massachusetts stipulates these additional requirements:*

- Gas furnaces shall be installed by a licensed plumber or fitter only.
- The gas cock must be "T handle" type.
- When a furnace is installed in an attic, the passageway to and service area surrounding the equipment shall be floored.

## Installation

### Setting Equipment

#### WARNING

Do not connect the return air ducts to the back of the furnace. Doing so will adversely affect the operation of the safety control devices, which could result in personal injury or death.

#### WARNING

Blower access panel must be securely in place when blower and burners are operating. If panels are left off, gas fumes, which could contain carbon monoxide, can be drawn into living space resulting in personal injury or death.

#### WARNING

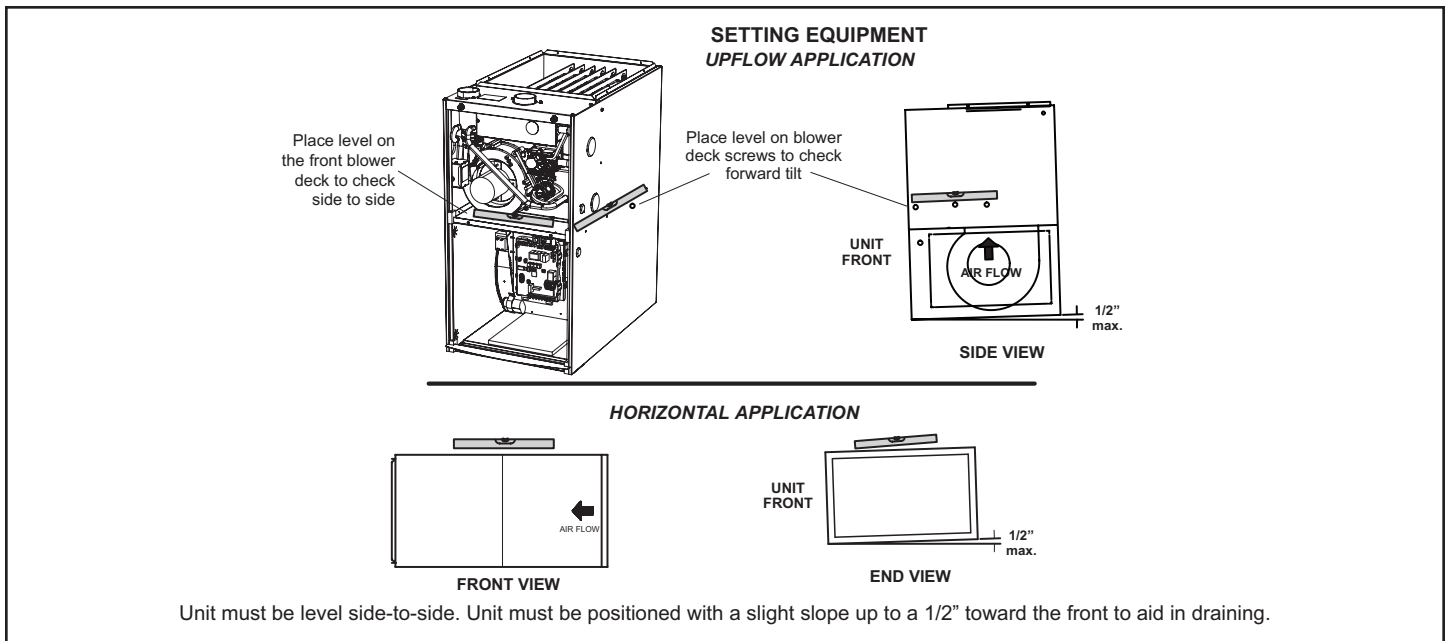
Improper installation of the furnace can result in personal injury or death. Combustion and flue products must never be allowed to enter the return air system or air in the living space. Use sheet metal screws and joint tape to seal return air system to furnace.

In platform installations with furnace return, the furnace should be sealed airtight to the return air plenum. A door must never be used as a portion of the return air duct system. The base must provide a stable support and an airtight seal to the furnace. Allow absolutely no sagging, cracks, gaps, etc.

For no reason should return and supply air duct systems ever be connected to or from other heating devices such as a fireplace or stove, etc. Fire, explosion, carbon monoxide poisoning, personal injury and/or property damage could result.

### Upflow Applications

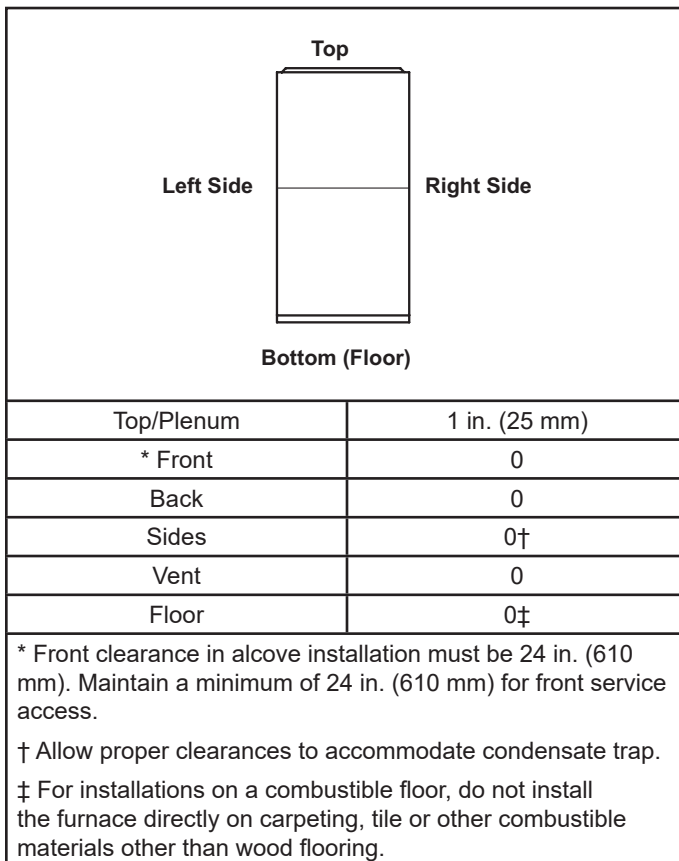
This gas furnace can be installed as shipped in the upflow position. Refer to Figure 5 for clearances.



**Figure 4.**

Allow for clearances to combustible materials as indicated on the unit nameplate. Minimum clearances for closet or alcove installations are shown in Figure 5.

Select a location that allows for the required clearances that are listed on the unit nameplate. Also consider gas supply connections, electrical supply, vent connection, condensate trap and drain connections, and installation and service clearances (24 inches [610 mm] at unit front). The unit must be level from side to side, for proper operation. Tilt the unit slightly (maximum 1/2 in. from level) from back to front to aid in the draining of the heat exchanger. See Figure 4.



**Figure 5. Installation Clearances  
Upflow Applications**

A98USMV applications that include side return air and a condensate trap installed on the same side of the cabinet (trap can be installed remotely within 5 feet) require either a return air base or field fabricated transition to accommodate an optional IAQ accessory taller than 14.5". See Figure 6.

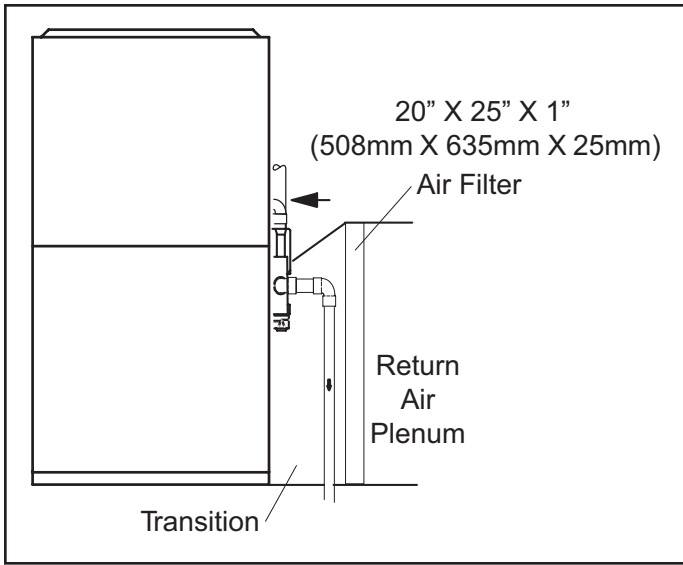
#### **Return Air – Upflow Units**

Return air can be brought in through the bottom or either side of the furnace installed in an upflow application. If the furnace is installed on a platform with bottom return, make an airtight seal between the bottom of the furnace and the platform to ensure that the furnace operates properly and safely. The furnace is equipped with a removable bottom panel to facilitate installation.

Markings are provided on both sides of the furnace cabinet for installations that require side return air. Cut the furnace cabinet at the maximum dimensions shown on Page 2.

#### **Setting an Upflow Unit**

When the side return air inlets are used in an upflow application, it may be necessary to install shims on the bottom of the furnace.



**Figure 6. Side Return Air (with Transition and Filter)**

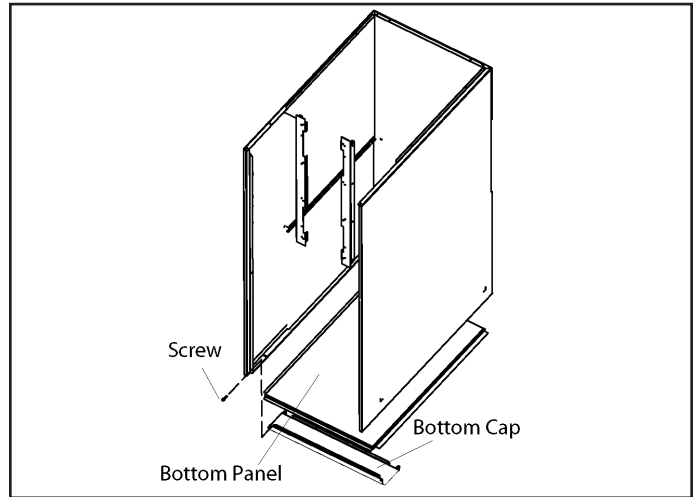
**Removing the Bottom Panel**

Remove the two screws that secure the bottom cap to the furnace. Pivot the bottom cap down to release the bottom panel. Once the bottom panel has been removed, reinstall the bottom cap. See Figure 7.

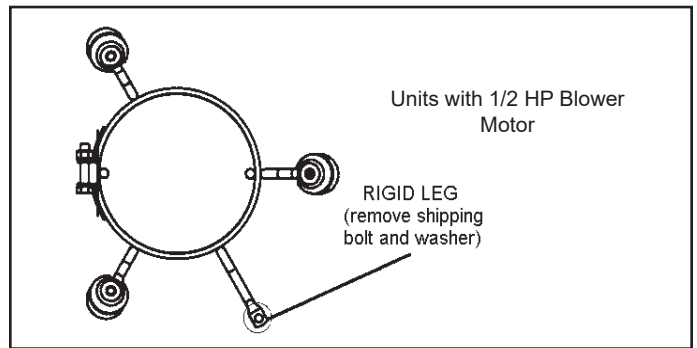
**Shipping Bolt Removal**

Units with 1/2 hp blower motor are equipped with three flexible legs and one rigid leg. The rigid leg is equipped with a shipping bolt and a flat white plastic washer (rather than the rubber mounting grommet used with a flexible mounting leg). See Figure 8. The bolt and washer must be

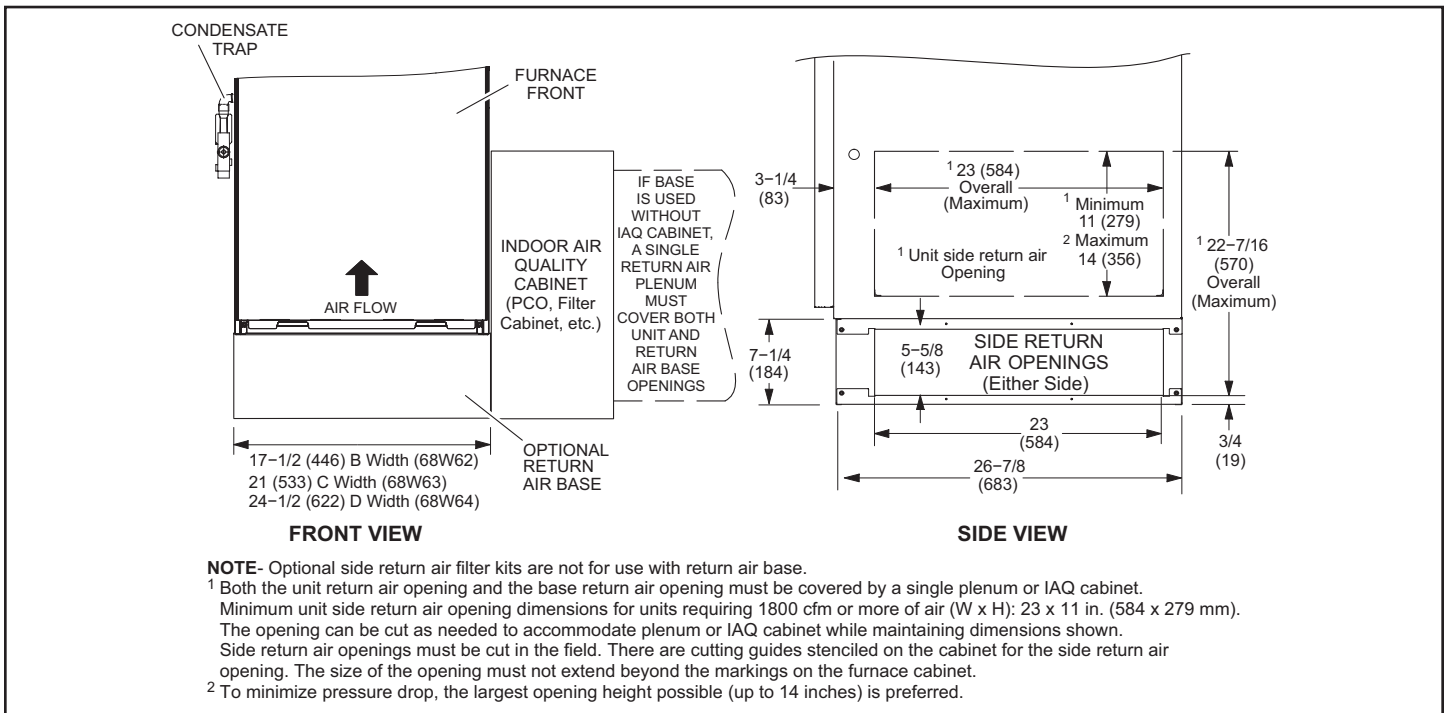
removed before the furnace is placed into operation. After the bolt and washer have been removed, the rigid leg will not touch the blower housing.



**Figure 7. Removing the Bottom Panel**



**Figure 8.**



**Figure 9. Optional Return Air Base (Upflow Applications Only)**



## Horizontal Applications

### WARNING

Do not install the furnace on its front or its back. See Figure 10.

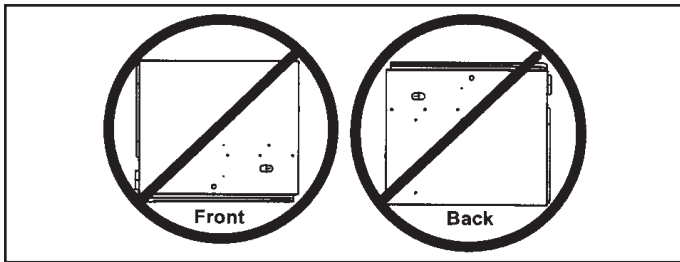


Figure 10.

The A98USMV furnace can be installed in horizontal applications with either right or left hand air discharge.

Refer to Figure 11 for clearances in horizontal applications.

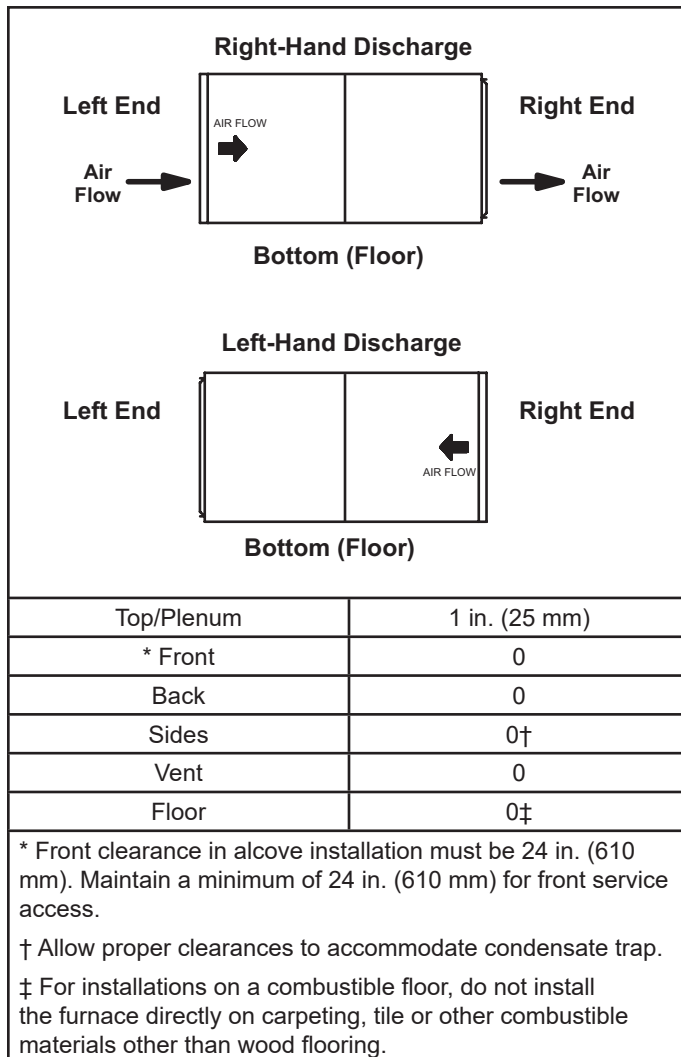


Figure 11. Installation Clearances Horizontal Applications

## Suspended Installation of Horizontal Unit

This furnace may be installed in either an attic or a crawlspace. Either suspend the furnace from roof rafters or floor joists, as shown in Figure 12 or install the furnace on a platform, as shown in Figure 13. A horizontal suspension kit (51W10) may be ordered or use equivalent.

**NOTE:** Heavy gauge sheet metal straps may be used to suspend the unit from roof rafters or ceiling joists. When straps are used to suspend the unit in this way, support must be provided for both the ends. The straps must not interfere with the plenum or exhaust piping installation. Cooling coils and supply and return air plenums must be supported separately.

**NOTE:** When the furnace is installed on a platform in a crawlspace, it must be elevated enough to avoid water damage and to allow the evaporator coil to drain.

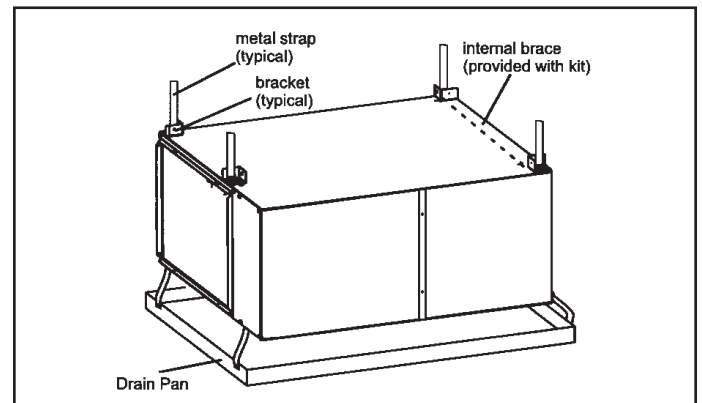


Figure 12. Typical Horizontal Application

## Platform Installation of Horizontal Unit

1. Select location for unit keeping in mind service and other necessary clearances. See Figure 11.
2. Construct a raised wooden frame and cover frame with a plywood sheet. If unit is installed above finished space, fabricate an auxiliary drain pan to be installed under unit. Set unit in drain pan as shown in Figure 13. Leave 8 inches for service clearance below unit for condensate trap, unless trap is installed remotely.
3. Provide a service platform in front of unit. When installing the unit in a crawl space, a proper support platform may be created using cement blocks.
4. Route auxiliary drain line so that water draining from this outlet will be easily noticed by the homeowner.
5. If necessary, run the condensate line into a condensate pump to meet drain line slope requirements. The pump must be rated for use with condensing furnaces. Protect the condensate discharge line from the pump to the outside to avoid freezing.
6. Continue with exhaust, condensate and intake piping installation according to instructions.

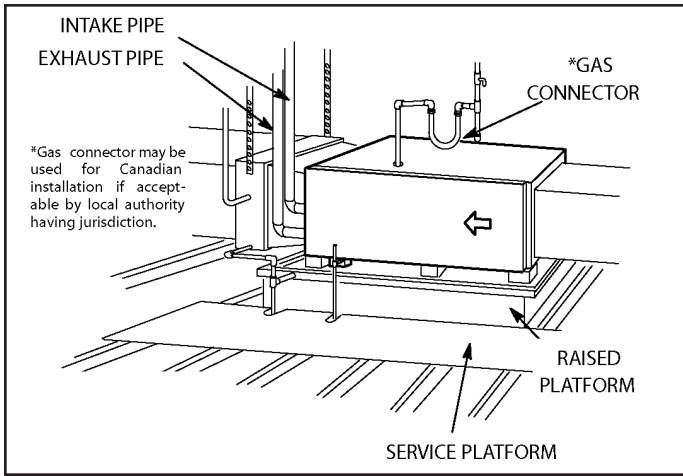


Figure 13.

### Return Air - Horizontal Applications

Return air must be brought in through the end of a furnace installed in the horizontal position. The furnace is equipped with a removable bottom panel to facilitate installation. See Figure 7.

### Filters

This unit is not equipped with a filter or rack. A field provided filter is required for the unit to operate properly. Table 1 lists recommended filter sizes.

**A filter must be in place when the unit is operating!**

**NOTE:** In upflow applications where side return air filter is installed on same side as the condensate trap, make sure that clearance is maintained to ensure future access to the filter access panel.

| Furnace Cabinet Width | Filter Size     |                 |
|-----------------------|-----------------|-----------------|
|                       | Side Return     | Bottom Return   |
| B (17-1/2")           | 16 x 25 x 1 (1) | 16 x 25 x 1 (1) |
| C (21")               |                 | 20 x 25 x 1 (1) |
| D (24-1/2")           |                 | 24 x 25 x 1 (1) |

Table 1.

### Duct System

Use industry approved standards to size and install the supply and return air duct system. This will result in a quiet and low static system that has uniform air distribution.

**NOTE:** Operation of this furnace in heating mode (indoor blower operating at selected heating speed) with an external static pressure that exceeds 0.8 inches w.c. may result in erratic limit operation.

### Supply Air Plenum

If the furnace is installed without a cooling coil, a removable access panel should be installed in the supply air duct. The access panel should be large enough to permit inspection (by reflected light) of the heat exchanger for leaks after the furnace is installed. If present, this access panel must always be in place when the furnace is operating and it must not allow leaks into or from the supply air duct system.

### Return Air Plenum

Return air must not be drawn from a room where this furnace, or any other gas fueled appliance (i.e., water heater), or carbon monoxide producing device (i.e., wood fireplace) is installed. When return air is drawn from a room, a negative pressure is created in the room. If a gas appliance is operating in a room with negative pressure, the flue products can be pulled back down the vent pipe and into the room. This reverse flow of the flue gas may result in incomplete combustion and the formation of carbon monoxide gas. This toxic gas might then be distributed throughout the house by the furnace duct system.

Return air can be brought in through the bottom or either side of the furnace. If a furnace with bottom return air is installed on a platform, make an airtight seal between the bottom of the furnace and the platform to ensure that the unit operates properly and safely. Use fiberglass sealing strips, caulking, or equivalent sealing method between the plenum and the furnace cabinet to ensure a tight seal. If a filter is installed, size the return air duct to fit the filter frame.

### Pipe and Fittings Specifications

All pipe, fittings, primer and solvent cement must conform with American National Standard Institute and the American Society for Testing and Materials (ANSI/ASTM) standards. The solvent shall be free flowing and contain no lumps, undissolved particles or any foreign matter that adversely affects the joint strength or chemical resistance of the cement. The cement shall show no gelation, stratification, or separation that cannot be removed by stirring. Refer to Table 2 for approved piping and fitting materials.

**⚠ CAUTION**

Solvent cements for plastic pipe are flammable liquids and should be kept away from all sources of ignition. Do not use excessive amounts of solvent cement when making joints. Good ventilation should be maintained to reduce fire hazard and to minimize breathing of solvent vapors. Avoid contact of cement with skin and eyes.

| Piping and Fittings Specifications  |                           |
|---|---------------------------|
| Schedule 40 PVC (Pipe)  | D1785                     |
| Schedule 40 PVC (Fittings)  | D2466                     |
| Schedule 40 CPVC (Pipe)   | F441                      |
| Schedule 40 CPVC (Fittings)   | F438                      |
| SDR-21 PVC or SDR-26 PVC (Pipe)   | D2241                     |
| SDR-21 CPVC or SDR-26 CPVC (Pipe)   | F442                      |
| Schedule 40 ABS (Pipe)  | D1527                     |
| Schedule 40 ABS (Fittings)  | D2468                     |
| ABS-DWV (Drain Waste & Vent)<br>(Pipe & Fittings)                           | D2661                     |
| PVC-DWV (Drain Waste & Vent)<br>Pipe & Fittings)                            | D2665                     |
| <b>PRIMER &amp; SOLVENT CEMENT</b>  | <b>ASTM SPECIFICATION</b> |
| PVC & CPVC Primer   | F656                      |
| PVC Solvent Cement  | D2564                     |
| CPVC Solvent Cement   | F493                      |
| ABS Solvent Cement  | D2235                     |
| PVC/CPVC/ABS All Purpose Cement For<br>Fittings & Pipe of the same material | D2564, D2235,<br>F493     |
| ABS to PVC or CPVC Transition Solvent<br>Cement                             | D3138                     |
| <b>CANADA PIPE &amp; FITTING &amp; SOLVENT<br/>CEMENT</b>                   | <b>MARKING</b>            |
| PVC & CPVC Pipe and Fittings  | ULCS636                   |
| PVC & CPVC Solvent Cement   |                           |
| ABS to PVC or CPVC Transition Cement  |                           |
| <b>POLYPROPYLENE VENTING SYSTEM</b>   | ULC-S636                  |
| PolyPro® by Duravent  |                           |
| InnoFlue® by Centrotherm  |                           |
| ECCO Polypropylene Vent™  |                           |

**Table 2.**

**⚠ IMPORTANT**

The exhaust and intake connections are made of PVC. Use PVC primer and solvent cement when using PVC vent pipe. When using ABS vent pipe, use transitional solvent cement to make connections to the PVC fittings in the unit.

Use PVC primer and solvent cement or ABS solvent cement meeting ASTM specifications, refer to Table 2. As an alternate, use all purpose cement, to bond ABS, PVC, or CPVC pipe when using fittings and pipe made of the same materials. Use transition solvent cement when bonding ABS to either PVC or CPVC.

Low temperature solvent cement is recommended. Metal or plastic strapping may be used for vent pipe hangers. Uniformly apply a liberal coat of PVC primer for PVC.

**Canadian Applications Only** – Pipe, fittings, primer and solvent cement used to vent (exhaust) this appliance must be certified to ULCS636 and supplied by a single manufacturer as part of an approved vent (exhaust) system. In addition, the first three feet of vent pipe from the furnace flue collar must be accessible for inspection.

Table 3 lists the available exhaust termination kits, as well as vent pipe equivalencies, which must be used when sizing vent pipe.

### Joint Cementing Procedure

All cementing of joints should be done according to the specifications outlined in ASTM D2855.

**⚠ DANGER**

**DANGER OF EXPLOSION!**

Fumes from PVC glue may ignite during system check. Allow fumes to dissipate for at least 5 minutes before placing unit into operation.

1. Measure and cut vent pipe to desired length.
2. Deburr and chamfer end of pipe, removing any ridges or rough edges. If end is not chamfered, edge of pipe may remove cement from fitting socket and result in a leaking joint.
3. Clean and dry surfaces to be joined.
4. Test fit joint and mark depth of fitting on outside of pipe.
5. Uniformly apply a liberal coat of PVC primer for PVC or use a clean dry cloth for ABS to clean inside socket surface of fitting and male end of pipe to depth of fitting socket.
6. Promptly apply solvent cement to end of pipe and inside socket surface of fitting. Cement should be applied lightly but uniformly to inside of socket. Take care to keep excess cement out of socket. Apply second coat to end of pipe.
 

**NOTE:** Time is critical at this stage. Do not allow primer to dry before applying cement.
7. Immediately after applying last coat of cement to pipe, and while both inside socket surface and end of pipe are wet with cement, forcefully insert end of pipe into socket until it bottoms out. Turn PVC pipe 1/4 turn

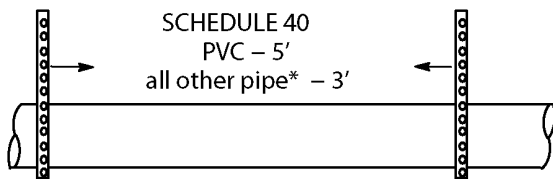
during assembly (but not after pipe is fully inserted) to distribute cement evenly. DO NOT turn ABS or cellular core pipe.

**NOTE:** Assembly should be completed within 20 seconds after last application of cement. Hammer blows should not be used when inserting pipe.

8. After assembly, wipe excess cement from pipe at end of fitting socket. A properly made joint will show a bead around its entire perimeter. Any gaps may indicate a defective assembly due to insufficient solvent.
9. Handle joints carefully until completely set.

## Venting Practices

### Piping Suspension Guidelines



\* See table 2 for allowable pipe.

**NOTE** – Isolate piping at the point where it exits the outside wall or roof in order to prevent transmission of vibration to the structure.

### Wall Thickness Guidelines

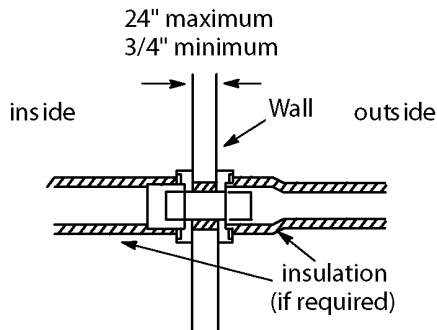


Figure 14.

1. In areas where piping penetrates joist or interior walls, hole must be large enough to allow clearance on all sides of pipe through center of hole using a hanger.
2. When furnace is installed in a residence where unit is shut down for an extended period of time, such as a vacation home, make provisions for draining condensate collection from trap and lines.

## Exhaust Piping

(Figure 18 and Figure 19)

1. Route piping to outside of structure. Continue with installation following instructions given in piping termination section.

## CAUTION

Do not discharge exhaust into an existing stack or stack that also serves another gas appliance. If vertical discharge through an existing unused stack is required, insert PVC pipe inside the stack until the end is even with the top or outlet end of the metal stack.

## CAUTION

The exhaust vent pipe operates under positive pressure and must be completely sealed to prevent leakage of combustion products into the living space.

## Vent Piping Guidelines

This unit is installed only as a Direct Vent gas central furnace.

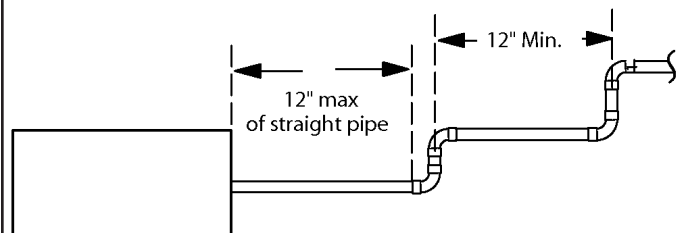
**NOTE:** In Direct Vent installations, combustion air is taken from outdoors and flue gases are discharged outdoors.

Intake and exhaust pipe sizing – Size pipe according to Table 4 and Table 6A through Table 6B. Table 4 lists the minimum vent pipe lengths permitted. Table 6A through Table 6B list the maximum pipe lengths permitted.

Regardless of the diameter of pipe used, the standard roof and wall terminations described in section Exhaust Piping Terminations should be used. Exhaust vent termination pipe is sized to optimize the velocity of the exhaust gas as it exits the termination. Refer to Table 7.

In some applications that permit the use of several different sizes of vent pipe, a combination vent pipe may be used. Contact Allied Air Technical Service for more information concerning sizing of vent systems that include multiple pipe sizes.

## Exhaust Pipe



### Horizontal Application

**NOTE** – All horizontal runs of exhaust pipe must slope back toward unit. A minimum of 1/4" (6 mm) drop for each 12" (305 mm) of horizontal run is mandatory for drainage.

**NOTE** – Exhaust pipe **MUST** be glued to furnace exhaust fittings.

**NOTE** – Exhaust piping should be checked carefully to make sure there are no sags or low spots.

Figure 15.

| Capacity | VENT PIPE DIA. (in.) | STANDARD                                    |   |                 | CONCENTRIC            |                   |                   |
|----------|----------------------|---|---|-----------------|-----------------------|-------------------|-------------------|
|          |                      | Outdoor Exhaust Accelerator (Dia. X Length) | Outdoor Exhaust Accelerator (Dia. X Length) | Flush Mount Kit | 1-1/2" Concentric Kit | 2" Concentric Kit | 3" Concentric Kit |
|          |                      | 1-1/2" x12"                                 | 2" x12"                                     | 51W11**         | 71M80 OR +44W92++     | 69M29 OR +44W92++ | 60L46 OR 44W93+   |
| 070      | <sup>1</sup> 1-1/2   |   |   | YES             | YES                   |                   |                   |
|          | 2                    | YES   |   | YES             | YES                   |                   |                   |
|          | 2-1/2"               | YES   |   | YES             | YES                   |                   |                   |
|          | 3                    | YES   |   | YES             | YES                   |                   |                   |
| 090      | 2                    |   | YES   | YES             |                       | YES               | YES               |
|          | 2-1/2"               |   | YES   | YES             |                       | YES               | YES               |
|          | 3                    |   | YES   | YES             |                       | YES               | YES               |
| 110      | 2                    |   | YES   | YES             |                       | YES               | YES               |
|          | 2-1/2"               |   | YES   | YES             |                       | YES               | YES               |
|          | 3                    |   | YES   | YES             |                       | YES               | YES               |
| 135      | 3                    |   | YES   | YES             |                       |                   | YES               |

<sup>1</sup> 2 inch to 1-1/2 inch reducer required, must be field provided.

\* Requires field provided end installed 1-1/2" exhaust accelerator.

\*\* Kit 51W11 is provided with a 1-1/2" accelerator which must be used for all 45,000 and 70,000 furnace installations. When using 1-1/2 in. piping, the pipe must be transitioned to 2 in. pipe when used with the Flush Mount Kit.

+ Termination kits 44W92, 44W93, 30G28 & 81J20 approved for use in Canadian installations to meet CSAB149.

++ The 44W92 Concentric kit is provided with a 1-1/2" accelerator which must be installed on the exhaust outlet when this kit is used with the 45,000 and 70,000 furnaces. When using 1-1/2 in. piping, the pipe must be transitioned to 2 in. pipe when used with the Concentric Kit.

**Table 3.**

**NOTE:** The exhaust collar on all models is sized to accommodate 2" Schedule 40 vent pipe. In horizontal applications, transition to exhaust pipe larger than 2" must be made in vertical runs of the pipe. A 2" elbow must be added before the pipe is transitioned to any size larger than 2". This elbow must be added to the elbow count used to determine acceptable vent lengths. Contact Allied Air Technical Service for more information concerning sizing of vent systems that include multiple pipe sizes.

| Capacity | Min. Vent Length | Example   |
|----------|------------------|---|
| 070      | 15 ft            | 5 ft. plus 2 elbows of 1-1/2", 2", 2-1/2" or 3" diameter pipe |
| 090      |                  | 5 ft. plus 2 elbows of 2", 2-1/2" or 3" diameter pipe         |
| 110      |                  | 5 ft. plus 2 elbows of 2-1/2" or 3" diameter pipe             |
| 135      |                  | 5 ft. plus 2 elbows of 3" diameter pipe                       |

**Table 4. Minimum Vent Pipe Lengths**

**⚠ IMPORTANT**

Do not use screens or perforated metal in exhaust or intake terminations. Doing so will cause freeze-ups and may block the terminations.

Use the steps in Figure 16 to correctly size vent pipe diameter.

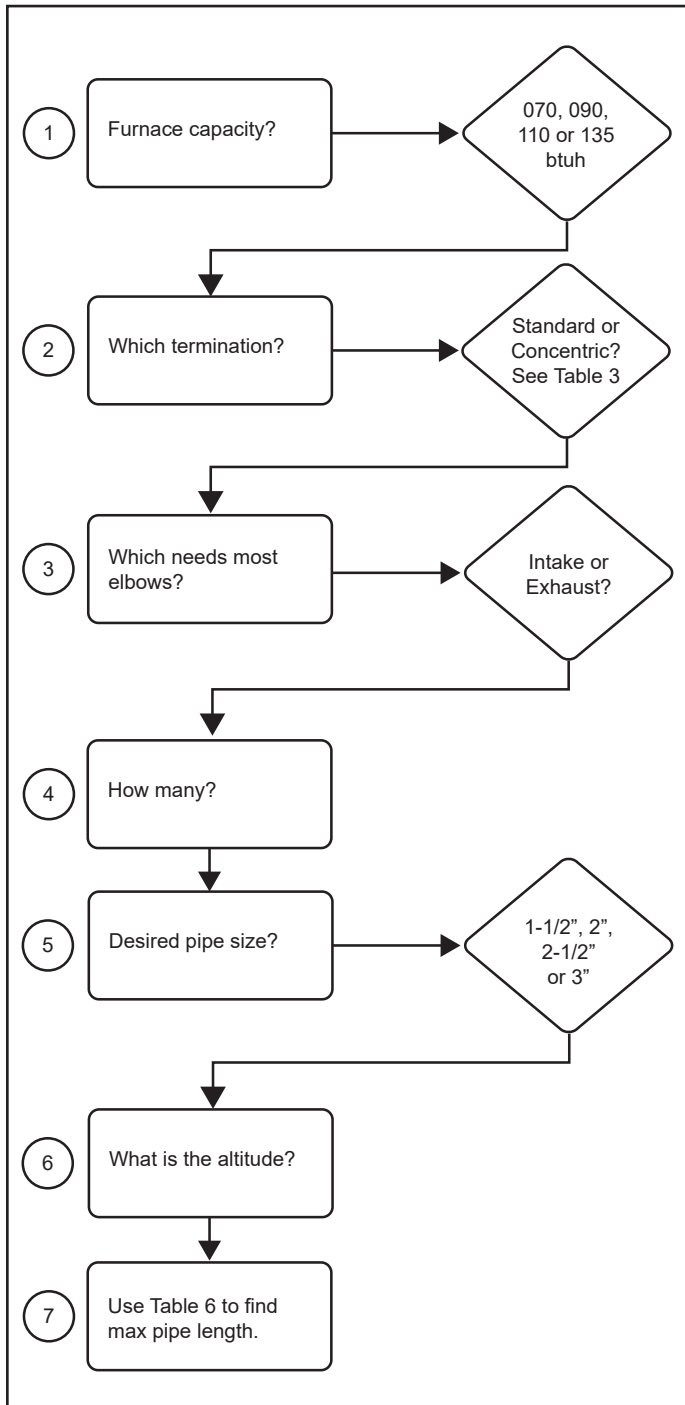


Figure 16.

### General Guidelines for Vent Terminations

In Direct Vent applications, combustion air is taken from outdoors and the flue gases are discharged to the outdoors. This gas furnace is classified as a direct vent, Category IV gas furnace.

In Direct Vent applications, the vent termination is limited by local building codes. In the absence of local codes, refer to the current National Fuel Gas Code ANSI Z223-1/

NFPA 54 in U.S.A., and current CSA-B149 Natural Gas and Propane Installation Codes in Canada for details.

Position termination according to location given in Figure 20. In addition, position termination so it is free from any obstructions and 12" above the average snow accumulation.

At vent termination, care must be taken to maintain protective coatings over building materials (prolonged exposure to exhaust condensate can destroy protective coatings). It is recommended that the exhaust outlet not be located within 6 feet (1.8m) of a condensing unit because the condensate can damage the painted coating.

**NOTE:** See Table 5 for maximum allowed exhaust pipe length without insulation in unconditioned space during winter design temperatures below 32°F (0°C). If required, exhaust pipe should be insulated with 1/2" (13mm) ArmaFlex® or equivalent. In extreme cold climate areas, 3/4" (19mm) ArmaFlex® or equivalent may be necessary. Insulation on outside runs of exhaust pipe must be painted or wrapped to protect insulation from deterioration. Exhaust pipe insulation may not be necessary in some specific applications.

**⚠ IMPORTANT**

**FOR CANADIAN INSTALLATIONS ONLY:**

In accordance to CSA International B149 installation codes, the minimum allowed distance between the combustion air intake inlet and the exhaust outlet of other appliances shall not be less than 12 inches (305 mm).

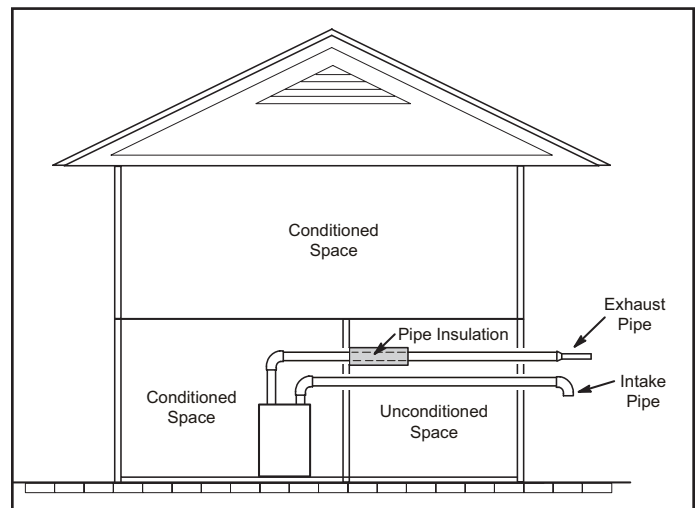
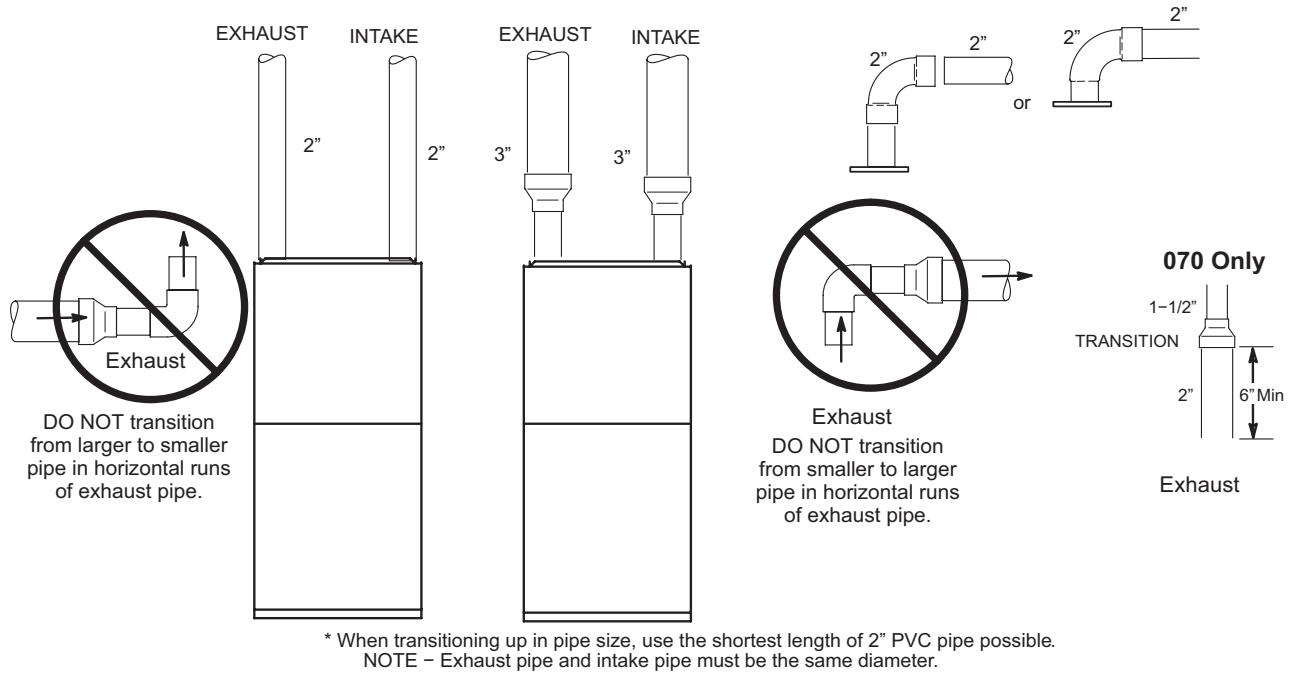


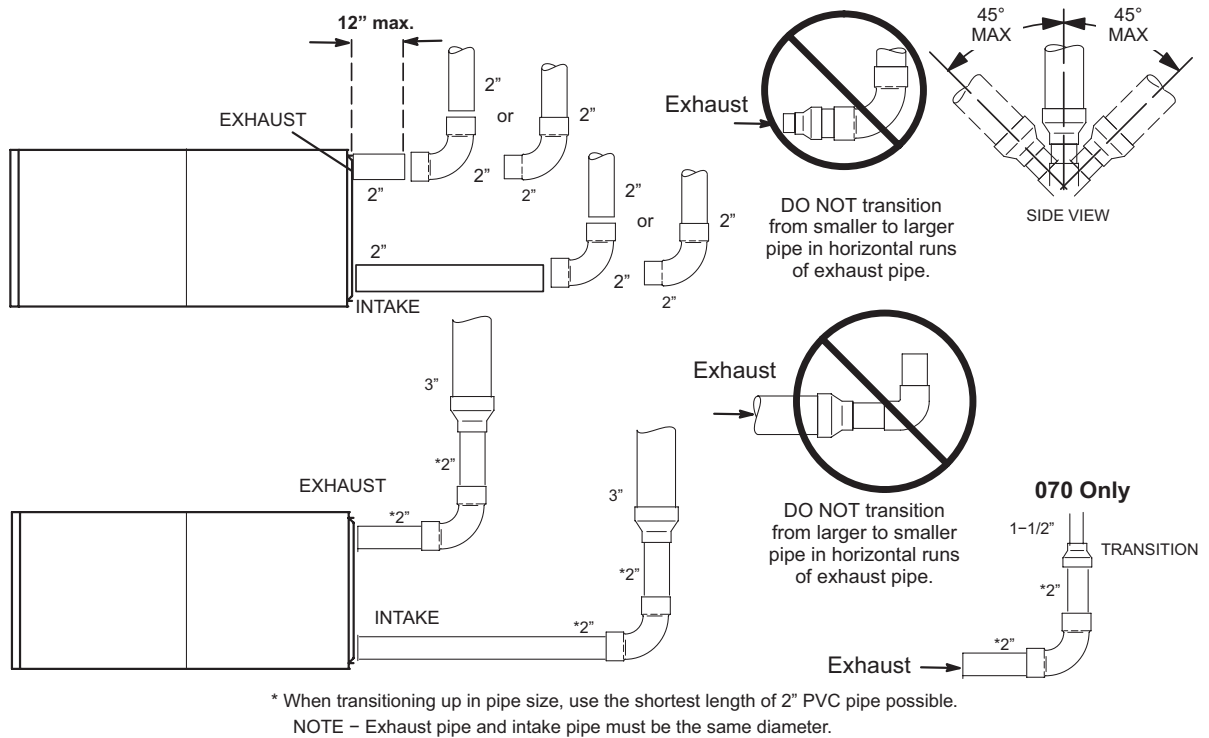
Figure 17. Insulating Exhaust Pipe in an Unconditioned Space

**TYPICAL EXHAUST AND INTAKE PIPE CONNECTIONS IN UPFLOW**



**Figure 18.**

**TYPICAL EXHAUST AND INTAKE PIPE CONNECTIONS IN HORIZONTAL  
 (RIGHT HAND DISCHARGE SHOWN)**



**Figure 19.**

**Maximum Allowable Exhaust Vent Pipe Length<sup>3</sup> (in ft.) without Insulation in Unconditioned Space For Winter Design Temperatures Single - Stage High Efficiency Furnace**

| Winter Design Temperatures <sup>1</sup><br>°F (°C) | Vent Pipe Diameter | Unit Input Size |                 |     |                 |     |                 |     |                 |
|--|--------------------|-----------------|-----------------|-----|-----------------|-----|-----------------|-----|-----------------|
|  |                    | 070             |                 | 090 |                 | 110 |                 | 135 |                 |
|  |                    | PVC             | <sup>2</sup> PP | PVC | <sup>2</sup> PP | PVC | <sup>2</sup> PP | PVC | <sup>2</sup> PP |
| 32 to 21<br>(0 to -6)                              | 1-1/2 in.          | 20              | N/A             | N/A | N/A             | N/A | N/A             | N/A | N/A             |
|  | 2 in.              | 31              | 28              | 50  | 48              | 30  | 30              | N/A | N/A             |
|  | 2-1/2 in.          | 24              | N/A             | 42  | N/A             | 56  | N/A             | N/A | N/A             |
|  | 3 in.              | 18              | 18              | 35  | 35              | 47  | 47              | 52  | 52              |
| 20 to 1<br>(-7 to -17)                             | 1-1/2 in.          | 20              | N/A             | N/A | N/A             | N/A | N/A             | N/A | N/A             |
|  | 2 in.              | 18              | 16              | 32  | 29              | 30  | 30              | N/A | N/A             |
|  | 2-1/2 in.          | 13              | N/A             | 24  | N/A             | 34  | N/A             | N/A | N/A             |
|  | 3 in.              | 8               | 8               | 19  | 19              | 26  | 26              | 30  | 30              |
| 0 to -20<br>(-18 to -29)                           | 1-1/2 in.          | 15              | N/A             | N/A | N/A             | N/A | N/A             | N/A | N/A             |
|  | 2 in.              | 12              | 10              | 22  | 19              | 30  | 27              | N/A | N/A             |
|  | 2-1/2 in.          | 7               | N/A             | 15  | N/A             | 22  | N/A             | N/A | N/A             |
|  | 3 in.              | N/A             | N/A             | 10  | 10              | 16  | 16              | 18  | 18              |

<sup>1</sup> Refer to 99% Minimum Design Temperature table provided in the current edition of the ASHRAE Fundamentals Handbook.

<sup>2</sup> Poly-Propylene vent pipe (PP) by Duravent and Centrotherm

<sup>3</sup> Vent length in table is equivalent length. Each elbow is equivalent to 5ft. of straight pipe and should be included when measuring total length.

NOTE- Maximum uninsulated vent lengths listed may include the termination (vent pipe exterior to the structure) and cannot exceed 5 linear feet or the maximum allowable intake or exhaust vent length listed in Table 6A through Table 6B or Table 5.

NOTE - If insulation is required in an unconditioned space, it must be located on the pipe closest to the furnace. See Figure 17.

NOTE - Concentric terminations are the equivalent of 5' and should be considered when measuring pipe length.

**Table 5.**



**Maximum Allowable Intake or Exhaust Vent Length (feet)**

| Standard Termination at Elevation 0 - 4,500 ft      |             |     |     |     |         |     |     |     |             |     |     |     |         |     |     |     |
|---|-------------|-----|-----|-----|---------|-----|-----|-----|-------------|-----|-----|-----|---------|-----|-----|-----|
| Number of 90° Elbows Used                           | 1-1/2" Pipe |     |     |     | 2" Pipe |     |     |     | 2-1/2" Pipe |     |     |     | 3" Pipe |     |     |     |
|   | Model       |     |     |     | Model   |     |     |     | Model       |     |     |     | Model   |     |     |     |
|   | 070         | 090 | 110 | 135 | 070     | 090 | 110 | 135 | 070         | 090 | 110 | 135 | 070     | 090 | 110 | 135 |
| 1   | 20          | n/a | n/a | n/a | 86      | 64  | n/a | n/a | 135         | 88  | 38  | n/a | 157     | 138 | 113 | 109 |
| 2   | 15          |     |     |     | 81      | 59  |     |     | 130         | 83  | 33  |     | 152     | 133 | 108 | 104 |
| 3   | 10          |     |     |     | 76      | 54  |     |     | 125         | 78  | 28  |     | 147     | 128 | 103 | 99  |
| 4   | n/a         |     |     |     | 71      | 49  |     |     | 120         | 73  | 23  |     | 142     | 123 | 98  | 94  |
| 5   |             |     |     |     | 66      | 44  |     |     | 115         | 68  | 18  |     | 137     | 118 | 93  | 89  |
| 6   |             |     |     |     | 61      | 39  |     |     | 110         | 63  | 13  |     | 132     | 113 | 88  | 84  |
| 7   |             |     |     |     | 56      | 34  |     |     | 105         | 58  | 8   |     | 127     | 108 | 83  | 79  |
| 8   |             |     |     |     | 51      | 29  |     |     | 100         | 53  | n/a |     | 122     | 103 | 78  | 74  |
| 9   |             |     |     |     | 46      | 24  |     |     | 95          | 48  |     |     | 117     | 98  | 73  | 69  |
| 10  | 41          |     |     |     | 19      | 90  |     |     | 43          | 112 | 93  |     | 68      | 64  |     |     |
| Standard Termination at Elevation 4,501 - 10,000 ft |             |     |     |     |         |     |     |     |             |     |     |     |         |     |     |     |
| Number of 90° Elbows Used                           | 1-1/2" Pipe |     |     |     | 2" Pipe |     |     |     | 2-1/2" Pipe |     |     |     | 3" Pipe |     |     |     |
|   | Model       |     |     |     | Model   |     |     |     | Model       |     |     |     | Model   |     |     |     |
|   | 070         | 090 | 110 | 135 | 070     | 090 | 110 | 135 | 070         | 090 | 110 | 135 | 070     | 090 | 110 | 135 |
| 1   | 12          | n/a | n/a | n/a | 61      | 39  | n/a | n/a | 110         | 63  | n/a | n/a | 132     | 113 | 88  | 84  |
| 2   | 7           |     |     |     | 56      | 34  |     |     | 105         | 58  |     |     | 127     | 108 | 83  | 79  |
| 3   | n/a         |     |     |     | 51      | 29  |     |     | 100         | 53  |     |     | 122     | 103 | 78  | 74  |
| 4   |             |     |     |     | 46      | 24  |     |     | 95          | 48  |     |     | 117     | 98  | 73  | 69  |
| 5   |             |     |     |     | 41      | 19  |     |     | 90          | 43  |     |     | 112     | 93  | 68  | 64  |
| 6   |             |     |     |     | 36      | 14  |     |     | 85          | 38  |     |     | 107     | 88  | 63  | 59  |
| 7   |             |     |     |     | 31      | 9   |     |     | 80          | 33  |     |     | 102     | 83  | 58  | 54  |
| 8   |             |     |     |     | 26      | n/a |     |     | 75          | 28  |     |     | 97      | 78  | 53  | 49  |
| 9   |             |     |     |     | 21      |     |     |     | 70          | 23  |     |     | 92      | 73  | 48  | 44  |
| 10  |             |     |     |     | 16      |     |     |     | 65          | 18  |     |     | 87      | 68  | 43  | 39  |

\*Size intake and exhaust pipe length separately. Values in table are for intake or exhaust not combined total. Both intake and exhaust must be same pipe size.

**Table 6A.**

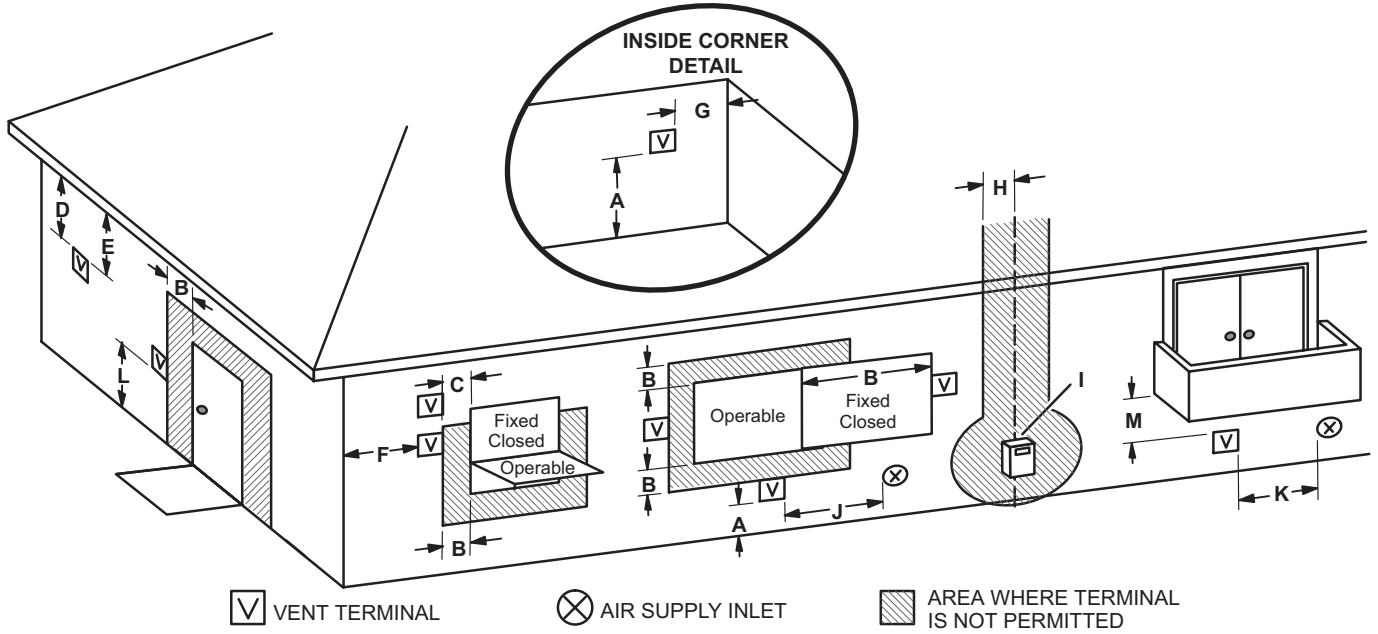
**Maximum Allowable Intake or Exhaust Vent Length (feet)**

| <b>Concentric Termination at Elevation 0 - 4,500 ft</b>      |                    |            |            |            |                |            |            |            |                    |            |            |            |                |            |            |            |
|--|--------------------|------------|------------|------------|----------------|------------|------------|------------|--------------------|------------|------------|------------|----------------|------------|------------|------------|
| <b>Number of 90° Elbows Used</b>                             | <b>1-1/2" Pipe</b> |            |            |            | <b>2" Pipe</b> |            |            |            | <b>2-1/2" Pipe</b> |            |            |            | <b>3" Pipe</b> |            |            |            |
|  | <b>Model</b>       |            |            |            | <b>Model</b>   |            |            |            | <b>Model</b>       |            |            |            | <b>Model</b>   |            |            |            |
|  | <b>070</b>         | <b>090</b> | <b>110</b> | <b>135</b> | <b>070</b>     | <b>090</b> | <b>110</b> | <b>135</b> | <b>070</b>         | <b>090</b> | <b>110</b> | <b>135</b> | <b>070</b>     | <b>090</b> | <b>110</b> | <b>135</b> |
| 1  | 15                 | n/a        | n/a        | n/a        | 78             | 62         | n/a        | n/a        | 125                | 84         | 34         | n/a        | 141            | 134        | 109        | 100        |
| 2  | 10                 |            |            |            | 73             | 57         |            |            | 120                | 79         | 29         |            | 136            | 129        | 104        | 95         |
| 3  | n/a                |            |            |            | 68             | 52         |            |            | 115                | 74         | 24         |            | 131            | 124        | 99         | 90         |
| 4  |                    |            |            |            | 63             | 47         |            |            | 110                | 69         | 19         |            | 126            | 119        | 94         | 85         |
| 5  |                    |            |            |            | 58             | 42         |            |            | 105                | 64         | 14         |            | 121            | 114        | 89         | 80         |
| 6  |                    |            |            |            | 53             | 37         |            |            | 100                | 59         | 9          |            | 116            | 109        | 84         | 75         |
| 7  |                    |            |            |            | 48             | 32         |            |            | n/a                | n/a        | n/a        |            | 111            | 104        | 79         | 70         |
| 8  |                    |            |            |            | 43             | 27         |            |            |                    |            |            |            | 106            | 99         | 74         | 65         |
| 9  |                    |            |            |            | 38             | 22         |            |            |                    |            |            |            | 101            | 94         | 69         | 60         |
| 10   |                    |            |            |            | 33             | 17         |            |            |                    |            |            |            | 96             | 89         | 64         | 55         |
| <b>Concentric Termination at Elevation 4,501 - 10,000 ft</b> |                    |            |            |            |                |            |            |            |                    |            |            |            |                |            |            |            |
| <b>Number of 90° Elbows Used</b>                             | <b>1-1/2" Pipe</b> |            |            |            | <b>2" Pipe</b> |            |            |            | <b>2-1/2" Pipe</b> |            |            |            | <b>3" Pipe</b> |            |            |            |
|  | <b>Model</b>       |            |            |            | <b>Model</b>   |            |            |            | <b>Model</b>       |            |            |            | <b>Model</b>   |            |            |            |
|  | <b>070</b>         | <b>090</b> | <b>110</b> | <b>135</b> | <b>070</b>     | <b>090</b> | <b>110</b> | <b>135</b> | <b>070</b>         | <b>090</b> | <b>110</b> | <b>135</b> | <b>070</b>     | <b>090</b> | <b>110</b> | <b>135</b> |
| 1  | 10                 | n/a        | n/a        | n/a        | 53             | 37         | n/a        | n/a        | 100                | 59         | n/a        | n/a        | 116            | 109        | 84         | 75         |
| 2  | n/a                |            |            |            | 48             | 32         |            |            | 95                 | 54         |            |            | 111            | 104        | 79         | 70         |
| 3  |                    |            |            |            | 43             | 27         |            |            | 90                 | 49         |            |            | 106            | 99         | 74         | 65         |
| 4  |                    |            |            |            | 38             | 22         |            |            | 85                 | 44         |            |            | 101            | 94         | 69         | 60         |
| 5  |                    |            |            |            | 33             | 17         |            |            | 80                 | 39         |            |            | 96             | 89         | 64         | 55         |
| 6  |                    |            |            |            | 28             | 12         |            |            | 75                 | 34         |            |            | 91             | 84         | 59         | 50         |
| 7  |                    |            |            |            | 23             | 7          |            |            | 70                 | 29         |            |            | 86             | 79         | 54         | 45         |
| 8  |                    |            |            |            | 18             | n/a        |            |            | 65                 | 24         |            |            | 81             | 74         | 49         | 40         |
| 9  |                    |            |            |            | 13             |            |            |            | 60                 | 19         |            |            | 76             | 69         | 44         | 35         |
| 10   |                    |            |            |            | 8              |            |            |            | 55                 | 14         |            |            | 71             | 64         | 39         | 30         |

\*Size intake and exhaust pipe length separately. Values in table are for intake or exhaust not combined total. Both intake and exhaust must be same pipe size.

**Table 6B.**

## VENT TERMINATION CLEARANCES FOR DIRECT VENT INSTALLATIONS IN THE USA AND CANADA



|     | US Installations <sup>1</sup>  | Canadian Installations <sup>2</sup>  |   |
|-----|--|--|---|
| A = | Clearance above grade, veranda, porch, deck or balcony   | 12 inches (305mm) or 12 inches (305mm) above average snow accumulation.  | 12 inches (305mm) or 12 inches (305mm) above average snow accumulation.   |
| B = | Clearance to window or door that may be opened   | 6 inches (152mm) for appliances <10,000 Btuh (3kw), 9 inches (228mm) for appliances > 10,000 Btuh (3kw) and <50,000 Btuh (15kw), 12 inches (305mm) for appliances > 50,000 Btuh (15kw) | 6 inches (152mm) for appliances <10,000 Btuh (3kw), 12 inches (305mm) for appliances > 10,000 Btuh (3kw) and <100,000 Btuh (30kw), 36 inches (.9m) for appliances > 100,000 Btuh (30kw) |
| C = | Clearance to permanently closed window   | * 12"  | * 12"   |
| D = | Vertical clearance to ventilated soffit located above the terminal within a horizontal distance of 2 feet (610mm) from the center line of the terminal | * Equal to or greater than soffit depth  | * Equal to or greater than soffit depth   |
| E = | Clearance to unventilated soffit   | * Equal to or greater than soffit depth  | * Equal to or greater than soffit depth   |
| F = | Clearance to outside corner  | * No minimum to outside corner   | * No minimum to outside corner  |
| G = | Clearance to inside corner   | *  | *   |
| H = | Clearance to each side of center line extended above meter / regulator assembly  | 3 feet (.9m) within a height 15 feet (4.5m) above the meter / regulator assembly   | 3 feet (.9m) within a height 15 feet (4.5m) above the meter / regulator assembly  |
| I = | Clearance to service regulator vent outlet   | * 3 feet (.9m)   | 3 feet (.9m)  |
| J = | Clearance to non-mechanical air supply inlet to building or the combustion air inlet to any other appliance  | 6 inches (152mm) for appliances <10,000 Btuh (3kw), 9 inches (228mm) for appliances > 10,000 Btuh (3kw) and <50,000 Btuh (15kw), 12 inches (305mm) for appliances > 50,000 Btuh (15kw) | 6 inches (152mm) for appliances <10,000 Btuh (3kw), 12 inches (305mm) for appliances > 10,000 Btuh (3kw) and <100,000 Btuh (30kw), 36 inches (.9m) for appliances > 100,000 Btuh (30kw) |
| K = | Clearance to mechanical air supply inlet   | 3 feet (.9m) above if within 10 feet (3m) horizontally   | 6 feet (1.8m)   |
| L = | Clearance above paved sidewalk or paved driveway located on public property  | * 7 feet (2.1m)  | 7 feet (2.1m)†  |
| M = | Clearance under veranda, porch, deck or balcony  | *12 inches (305mm)‡  | 12 inches (305mm)‡  |

<sup>1</sup> In accordance with the current ANSI Z223.1/NFPA 54 Natural Fuel Gas Code

<sup>2</sup> In accordance with the current CSA B149.1, Natural Gas and Propane Installation Code

† A vent shall not terminate directly above a sidewalk or paved driveway that is located between two single family dwellings and serves both dwellings.

‡ Permitted only if veranda, porch, deck or balcony is fully open on a minimum of two sides beneath the floor. Avoiding this location is recommended if possible.

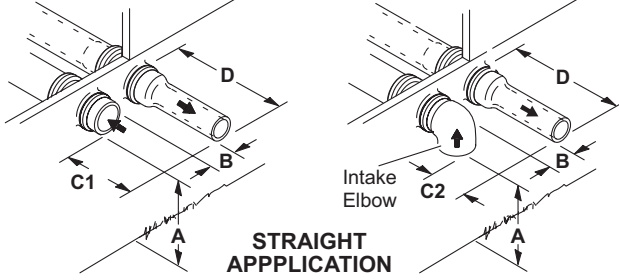
\*For clearances not specified in ANSI Z223.1/NFPA 54 or CSA B149.1, clearance will be in accordance with local installation codes and the requirements of the gas supplier and these installation instructions."

**NOTE** - This figure is intended to illustrate clearance requirements and does not serve as a substitute for locally adopted installation codes.

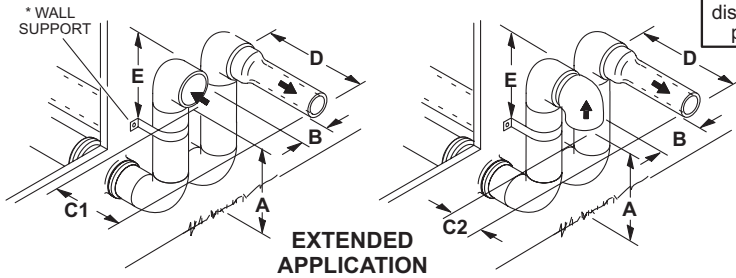
**Figure 20. Vent Termination Clearances for Direct Vent Installations in the USA and Canada**

## FIELD FABRICATED WALL TERMINATION

NOTE - FIELD-PROVIDED REDUCER MAY BE REQUIRED TO ADAPT LARGER VENT PIPE SIZE TO TERMINATION



**STRAIGHT APPLICATION**

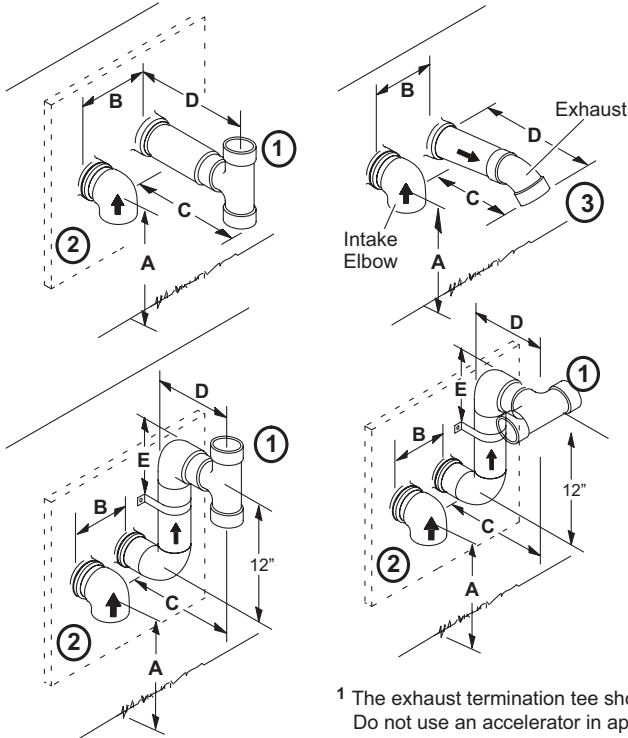


**EXTENDED APPLICATION**

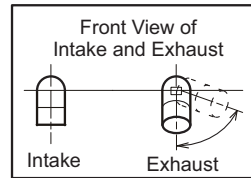
|   | <b>2" (51mm)<br/>Vent Pipe</b> | <b>3" (76mm)<br/>Vent Pipe</b> |
|---|--------------------------------|--------------------------------|
| <b>A</b> - Minimum clearance above grade or average snow accumulation           | 12" (305 mm)                   | 12" (305 mm)                   |
| <b>B</b> - Maximum horizontal separation between intake and exhaust             | 6" (152 mm)                    | 6" (152 mm)                    |
| <b>C1</b> -Minimum from end of exhaust to inlet of intake                       | 8" (203 mm)                    | 8" (203 mm)                    |
| <b>C2</b> -Minimum from end of exhaust to inlet of intake                       | 6" (152 mm)                    | 6" (152 mm)                    |
| <b>D</b> - Maximum exhaust pipe length  | 12" (305 mm)                   | 20" (508 mm)                   |
| <b>E</b> - Maximum wall support distance from top of each pipe (intake/exhaust) | 6" (152 mm)                    | 6" (152 mm)                    |

\* Use wall support every 24" (610 mm). Use two wall supports if extension is greater than 24" (610 mm) but less than 48" (1219 mm).  
NOTE - One wall support must be within 6" (152 mm) from top of each pipe (intake and exhaust) to prevent movement in any direction.

## ALTERNATE TERMINATIONS (TEE & FORTY-FIVE DEGREE ELBOWS ONLY)



|   | <b>2" (51MM)<br/>Vent Pipe</b>         | <b>3" (76MM)<br/>Vent Pipe</b>         |
|---|--|--|
| <b>A</b> - Clearance above grade or average snow accumulation           | 12" (305 mm) Min.                      | 12" (305 mm) Min.                      |
| <b>B</b> - Horizontal separation between intake and exhaust             | 6" (152 mm) Min.<br>24" (610 mm) Max.  | 6" (152 mm) Min.<br>24" (610 mm) Max.  |
| <b>C</b> - Minimum from end of exhaust to inlet of intake               | 9" (227 mm) Min.                       | 9" (227 mm) Min.                       |
| <b>D</b> - Exhaust pipe length  | 12" (305 mm) Min.<br>16" (405 mm) Max. | 12" (305 mm) Min.<br>20" (508 mm) Max. |
| <b>E</b> - Wall support distance from top of each pipe (intake/exhaust) | 6" (152 mm) Max.                       | 6" (152 mm) Max.                       |



- 1** The exhaust termination tee should be connected to the 2" or 3" PVC flue pipe as shown in the illustration. Do not use an accelerator in applications that include an exhaust termination tee. The accelerator is not required.
- 2** As required. Flue gas may be acidic and may adversely affect some building materials. If a side wall vent termination is used and flue gases will impinge on the building materials, a corrosion-resistant shield (24 inches square) should be used to protect the wall surface. If optional tee is used, the protective shield is recommended. The shield should be constructed using wood, sheet metal or other suitable material. All seams, joints, cracks, etc. in affected area, should be sealed using an appropriate sealant.
- 3** Exhaust pipe 45° elbow can be rotated to the side away from the combustion air inlet to direct exhaust away from adjacent property. The exhaust must never be directed toward the combustion air inlet.

**Figure 21.**

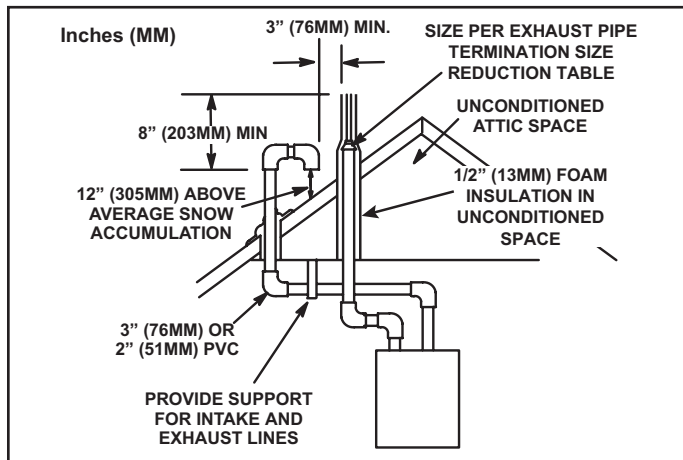
## Details of Intake and Exhaust Piping Terminations for Direct Vent Installations

**NOTE:** In Direct Vent installations, combustion air is taken from outdoors and flue gases are discharged to outdoors.

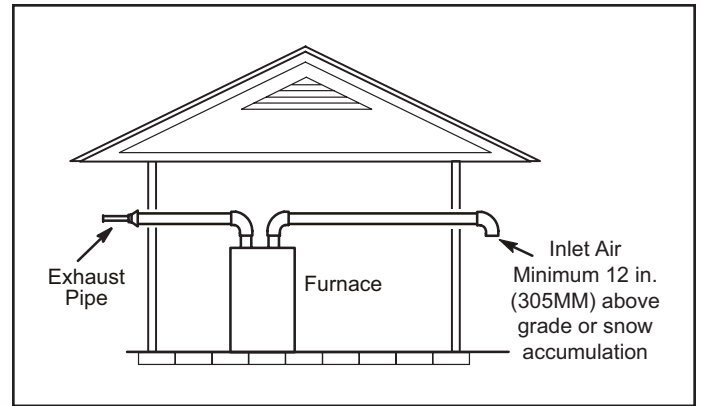
**NOTE:** Flue gas may be slightly acidic and may adversely affect some building materials. If any vent termination is used and the flue gasses may impinge on the building material, a corrosion resistant shield (minimum 24 inches square) should be used to protect the wall surface. If the optional tee is used, the protective shield is recommended. The shield should be constructed using wood, plastic, sheet metal or other suitable material. All seams, joints, cracks, etc. in the affected area should be sealed using an appropriate sealant. See Figure 21.

Intake and exhaust pipes may be routed either horizontally through an outside wall or vertically through the roof. In attic or closet installations, vertical termination through the roof is preferred. Figure 22 through Figure 29 show typical terminations.

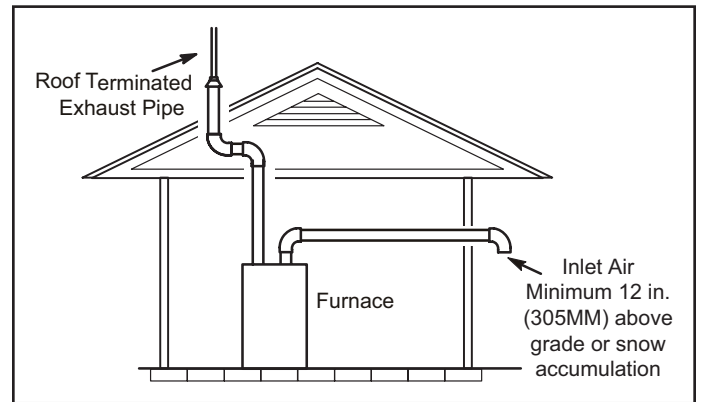
1. Intake and exhaust terminations are not required to be in the same pressure zone. You may exit the intake on one side of the structure and the exhaust on another side (Figure 23). You may exit the exhaust out the roof and the intake out the side of the structure (Figure 24).
2. Intake and exhaust pipes should be placed as close together as possible at termination end. Minimum separation is 3" (76 mm) on roof terminations and 6" (152 mm) on sidewall terminations.
3. On roof terminations, the intake piping should terminate straight down using two 90° elbows (Figure 22).
4. Exhaust piping must terminate straight out or up as shown. A reducer may be required on the exhaust piping at the point where it exits the structure to improve the velocity of exhaust away from the intake piping. See Table 7.



**Figure 22. Direct Vent Roof Termination Kit (15F75 or 44J41)**



**Figure 23. Exiting Exhaust and Intake Vent (no common pressure zone)**



**Figure 24. Exiting Exhaust and Intake Vent (no common pressure zone)**

| Capacity    | Exhaust Pipe Size                         | Termination Pipe Size |
|-------------|---|-----------------------|
| 045 and 070 | 2" (51mm),<br>2-1/2" (64mm),<br>3" (76mm) | 1-1/2" (38mm)         |
| 090         |   | 2" (51mm)             |
| 110         |   |                       |
| 135         | 3" (76mm)                                 |                       |

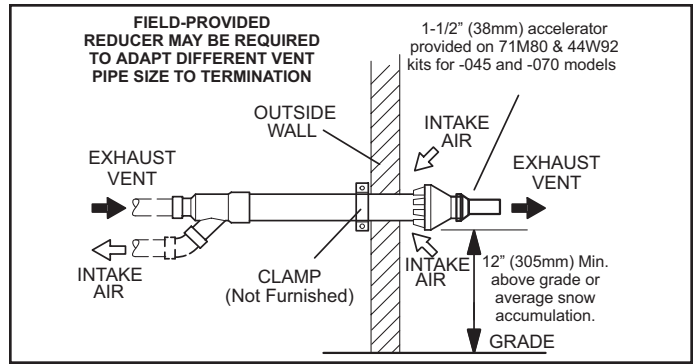
\* Units with the flush mount termination must use the 1-1/2" accelerator supplied with the kit

**Table 7. Exhaust Pipe Termination Size Reduction**

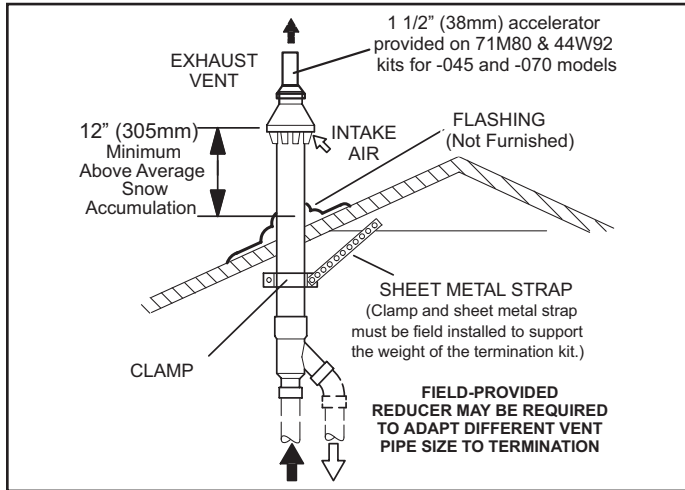
**NOTE:** Care must be taken to avoid recirculation of exhaust back into intake pipe.

5. On field supplied terminations for sidewall exit, exhaust piping may extend a maximum of 12 inches (305 mm) for 2" PVC and 20 inches (508 mm) for 3" (76 mm) PVC beyond the outside wall. Intake piping should be as short as possible. See Figure 21.
6. On field supplied terminations, a minimum distance between the end of the exhaust pipe and the end of the intake pipe without a termination elbow is 8" and a minimum distance of 6" with a termination elbow. See Figure 21.

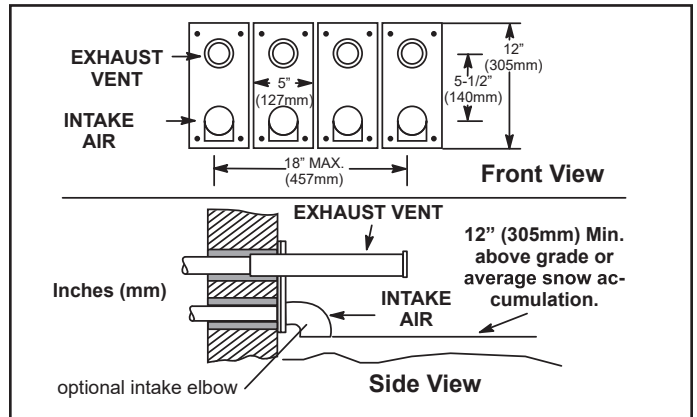
7. If intake and exhaust piping must be run up a side wall to position above snow accumulation or other obstructions, piping must be supported every 24" (610 mm) as shown in Figure 21. Exhaust and intake piping that is run up a wall is considered to be in an unconditioned space, so piping should be sized according to Table 5. The intake piping may be equipped with a 90° elbow turndown. Using a turndown will add 5 feet (1.5 m) to the equivalent length of the pipe.
8. A multiple furnace installation may use a group of up to four terminations assembled together horizontally, as shown in Figure 28.



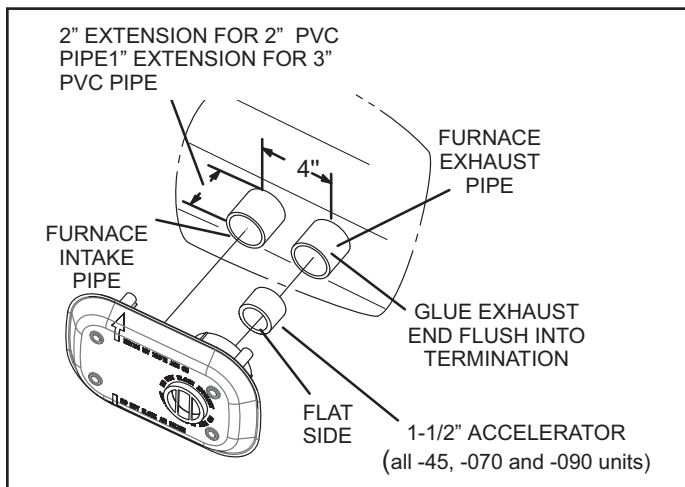
**Figure 27. Direct Vent Concentric Wall Termination  
71M80, 69M29 OR 60L46 (US)  
41W92 or 41W93 (Canada)**



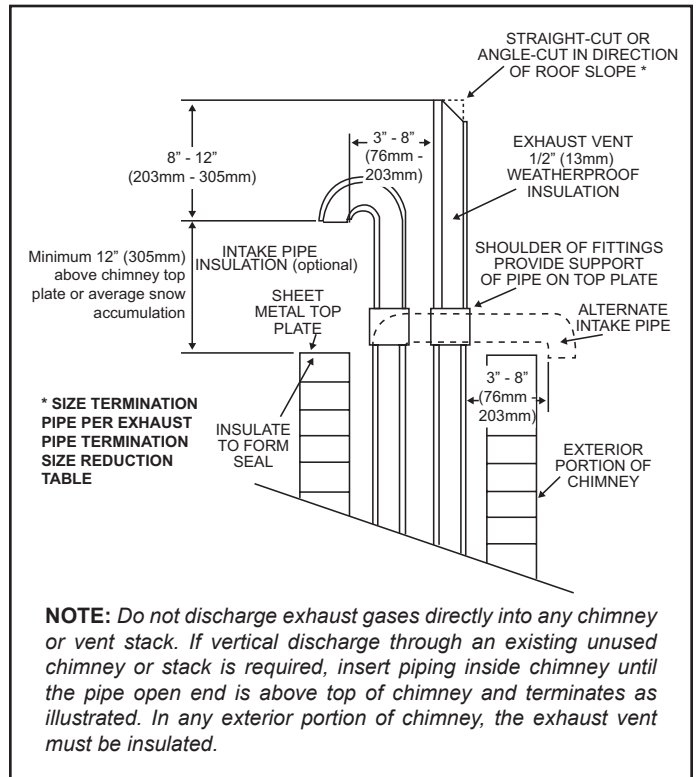
**Figure 25. Direct Vent Concentric Rooftop Termination  
71M80, 69M29 or 60L46 (US)  
41W92 or 41W93 (Canada)**



**Figure 28. Optional Vent Termination for Multiple Unit Installation of Direct Vent Wall Termination**



**Figure 26. Flush-Mount Side Wall Termination  
51W11**



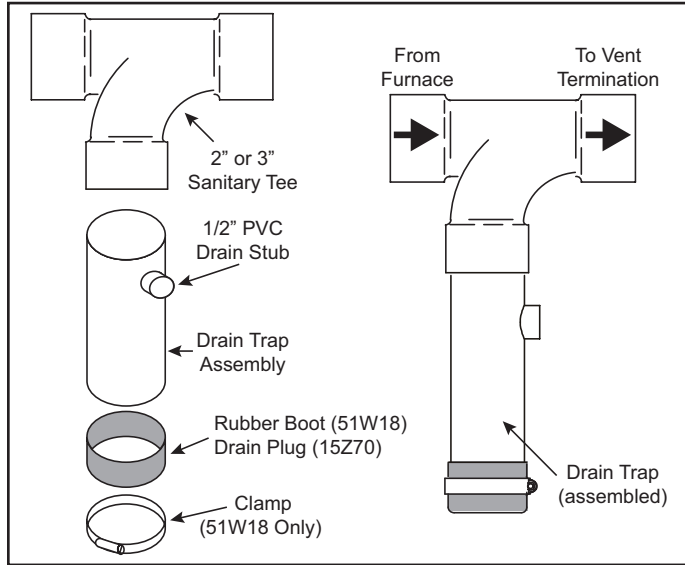
**NOTE:** Do not discharge exhaust gases directly into any chimney or vent stack. If vertical discharge through an existing unused chimney or stack is required, insert piping inside chimney until the pipe open end is above top of chimney and terminates as illustrated. In any exterior portion of chimney, the exhaust vent must be insulated.

**Figure 29. Direct Vent Application Using Existing Chimney**

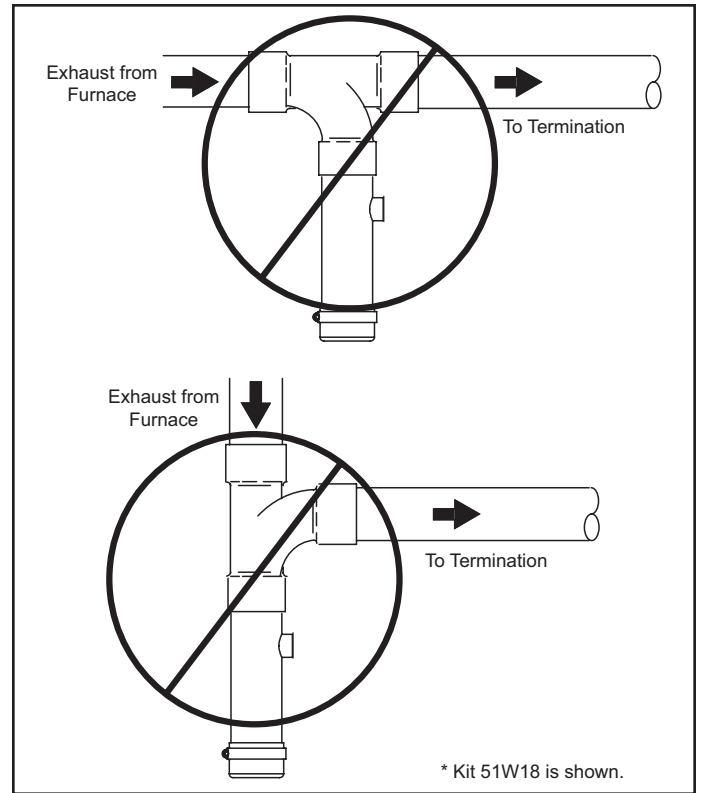
### Exhaust through Crawl Space Vent Option

All 33" condensing gas furnaces (92%+) are now approved to be vented down through a crawl space. Ensure a vent pipe drain kit, 51W18 (USA) or 15Z70 (Canada), is used as directed through the floor joists and into the crawl space. See the following figures.

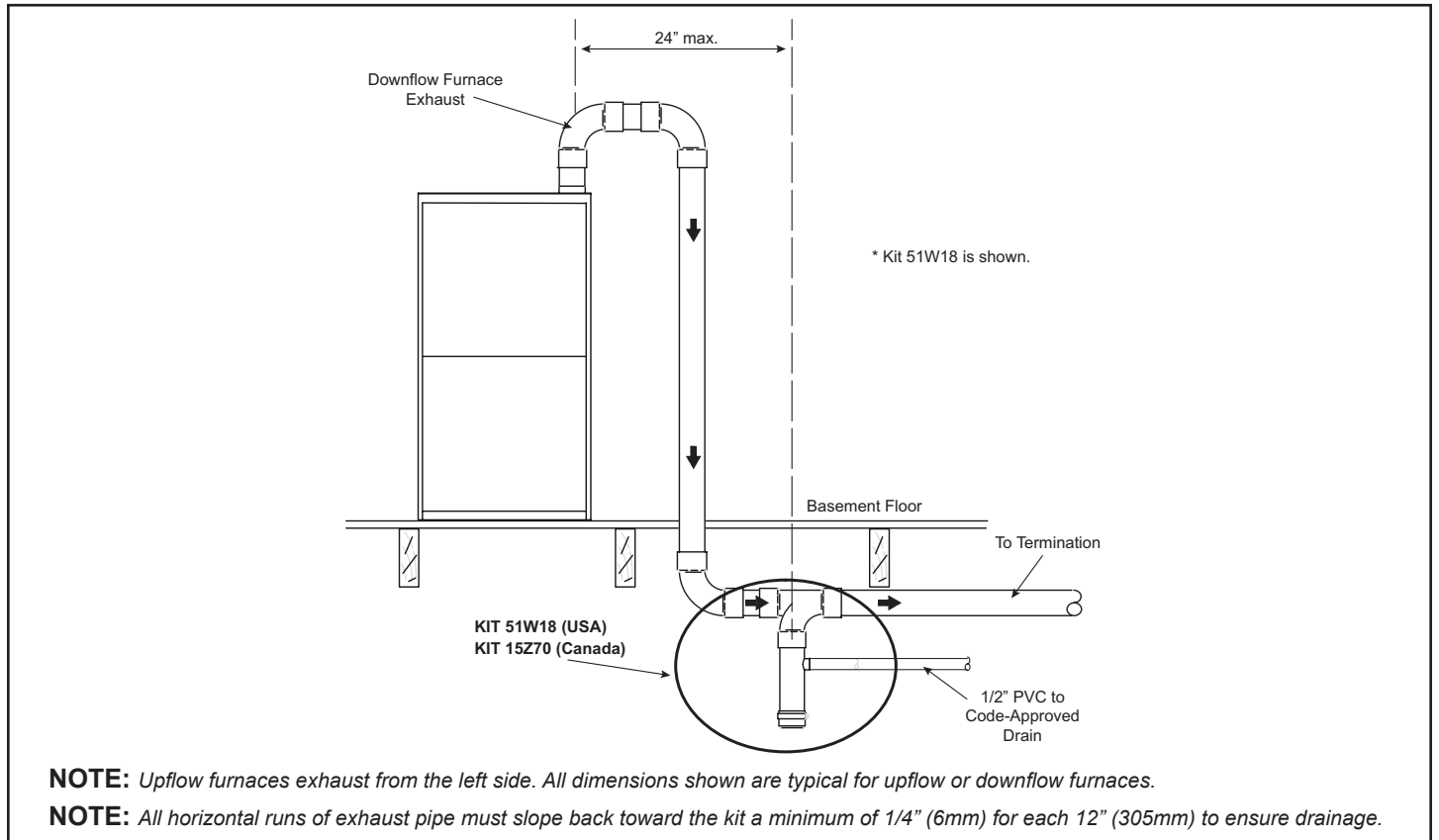
Consult the vent tables for vent lengths and approved materials.



**Figure 30. Kit 51W18 (USA) / 15Z70 (Canada) Parts Identification and Assembly**



**Figure 31. Crawl Space Vent Pipe Drain Trap Assembled Incorrectly**



**NOTE:** Upflow furnaces exhaust from the left side. All dimensions shown are typical for upflow or downflow furnaces.

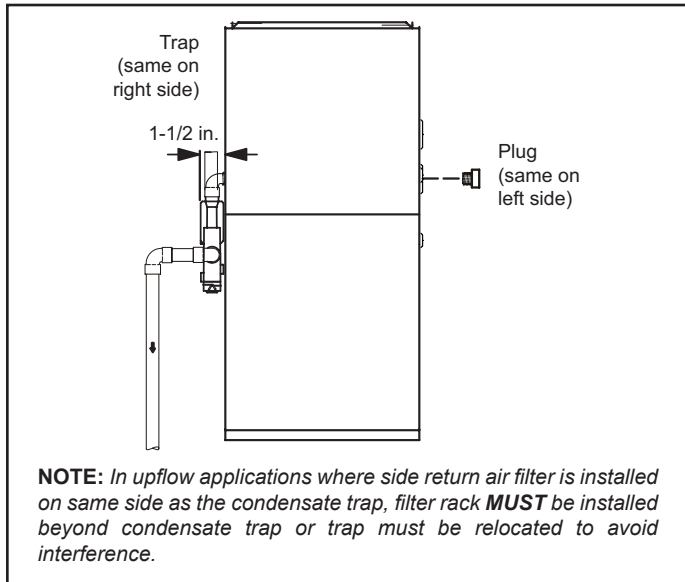
**NOTE:** All horizontal runs of exhaust pipe must slope back toward the kit a minimum of 1/4" (6mm) for each 12" (305mm) to ensure drainage.

**Figure 32. Upflow or Downflow Furnace with Exhaust through Crawl Space**

## Condensate Piping

This unit is designed for either right or left side exit of condensate piping in upflow applications. In horizontal applications, the condensate trap must extend below the unit. An 8" service clearance is required for the condensate trap. Refer to Figure 33 for condensate trap locations.

**NOTE:** If necessary the condensate trap may be installed up to 5 ft. away using PVC pipe from the furnace. Piping from furnace must slope down a minimum of 1/4" per ft. toward trap.



**Figure 33. Condensate Trap and Plug Locations (Unit shown in upflow position)**

1. Determine which side condensate piping will exit the unit, location of trap, field-provided fittings and length of PVC pipe required to reach available drain.
2. Use a 1/2" ratchet drive or flat blade screw driver and remove plug (Figure 33) from the cold end header box at the appropriate location on the side of the unit. Install field-provided 3/4 NPT male fitting into cold end header box. Use Teflon tape or appropriate pipe dope.
3. Install the cap over the clean out opening at the base of the trap. Secure with clamp. See Figure 35.
4. Install drain trap using appropriate PVC fittings; glue all joints. Glue the provided drain trap as shown in Figure 35. Route the condensate line to an open drain. Condensate line must maintain a 1/4" downward slope from the furnace to the drain.
5. Figure 36 and Figure 37 show the furnace and evaporator coil using a separate drain. If necessary, the condensate line from the furnace and evaporator coil can drain together. See Figure 38 and Figure 39.

Upflow furnace (Figure 34) - In upflow furnace applications, the field provided vent must be minimum 1" to a maximum 2" length above the condensate drain outlet connection. Any length above 2" may result in a flooded heat exchanger if the combined primary drain

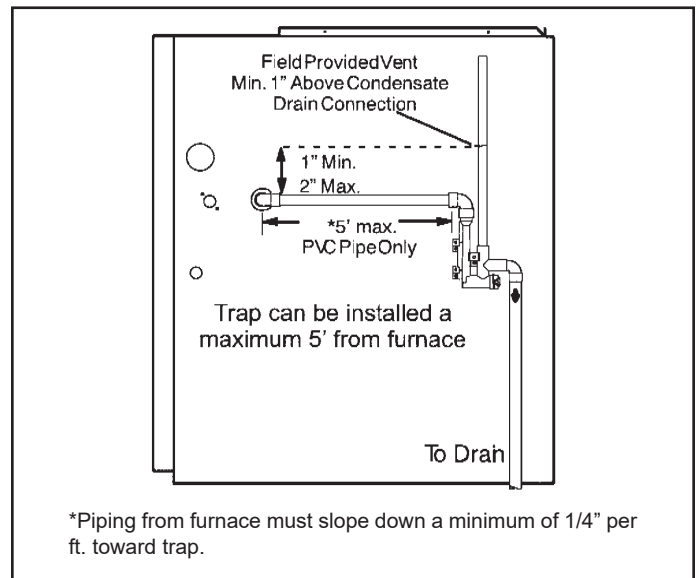
line were to become restricted.

Horizontal furnace (Figure 36 or Figure 39) - In horizontal furnace applications, the field provided vent must be a minimum 4" to a maximum 5" length above the condensate drain outlet connection. Any length above 5" may result in a flooded heat exchanger if the combined primary drain line were to become restricted.

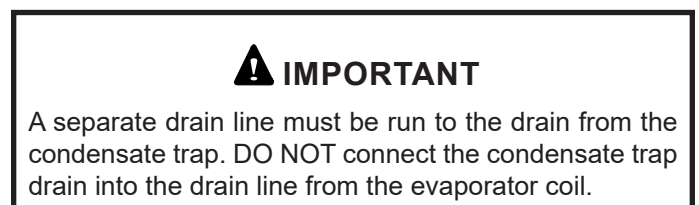
**NOTE:** In horizontal applications it is recommended to install a secondary drain pan underneath the unit and trap assembly.

6. If unit will be started immediately upon completion of installation, prime trap per procedure outlined in Unit Start-Up section.

Condensate line must slope downward away from the trap to drain. If drain level is above condensate trap, condensate pump must be used. Condensate drain line should be routed within the conditioned space to avoid freezing of condensate and blockage of drain line. If this is not possible, a heat cable kit may be used on the condensate trap and line. Heating cable kit is available in various lengths; 6 ft. (1.8 m) - kit no. 26K68; 24 ft. (7.3 m) - kit no. 26K69; and 50 ft. (15.2 m) - kit no. 26K70.

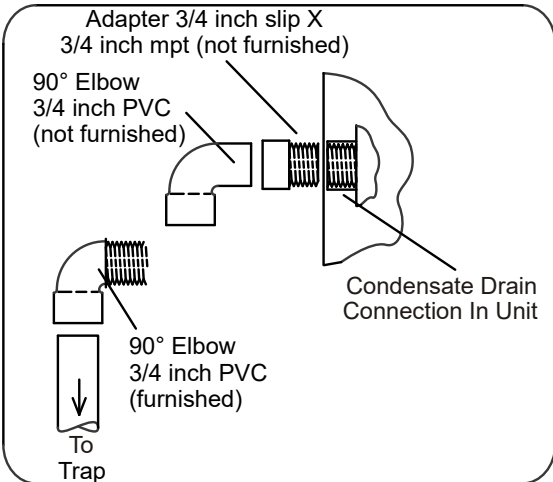


**Figure 34. Condensate Trap Locations (Unit shown in upflow position with remote trap)**

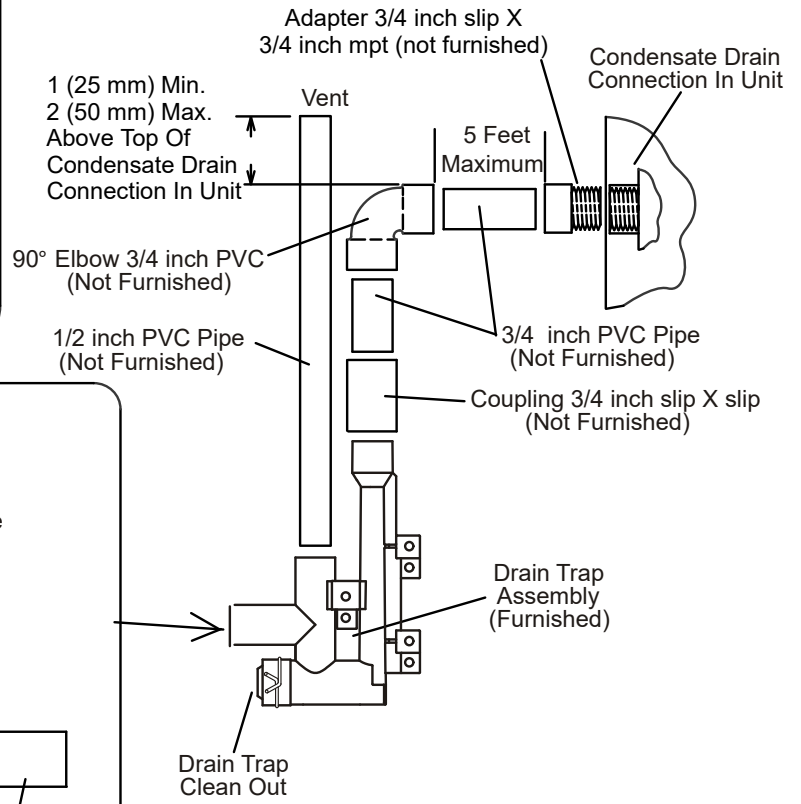
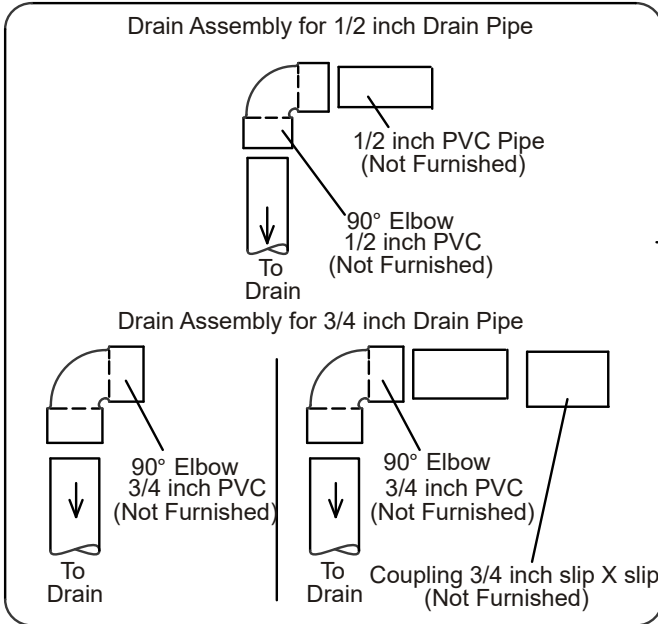




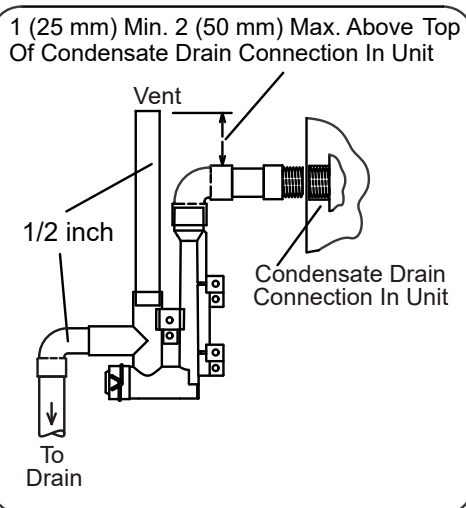
Optional Condensate Drain Connection



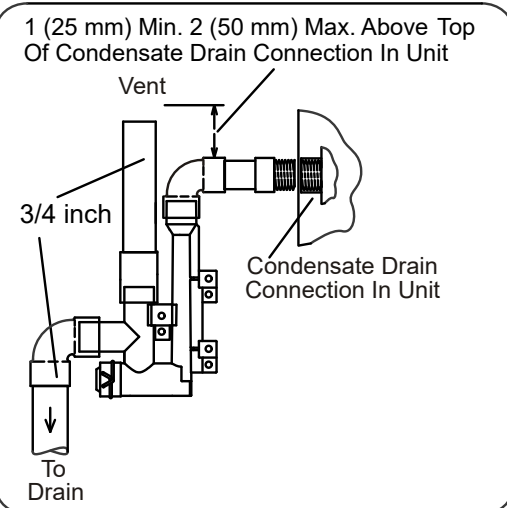
Optional Drain Piping From Trap



Drain Trap Assembly with 1/2 inch Piping



Drain Trap Assembly with 3/4 inch Piping



Drain Trap Assembly (Furnished)

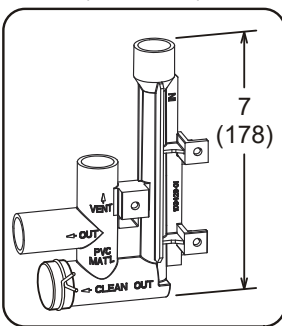
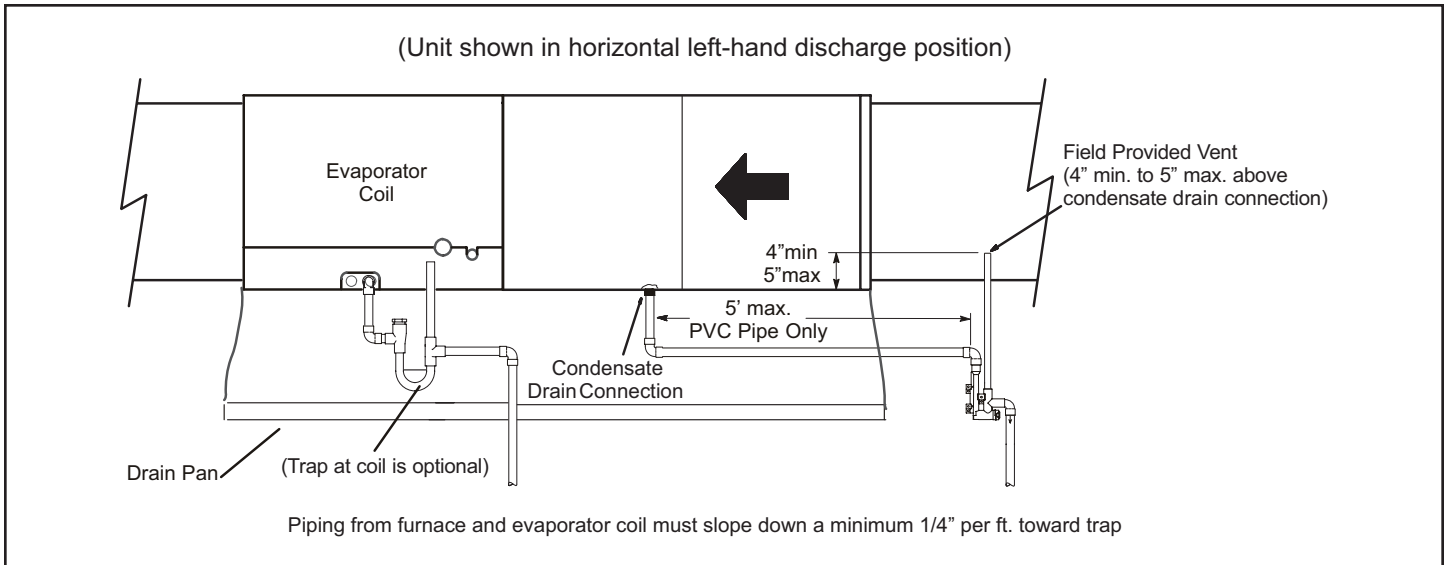
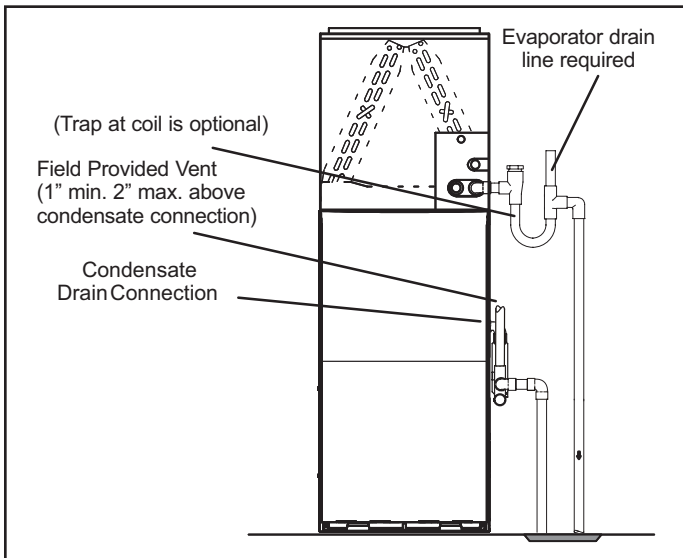


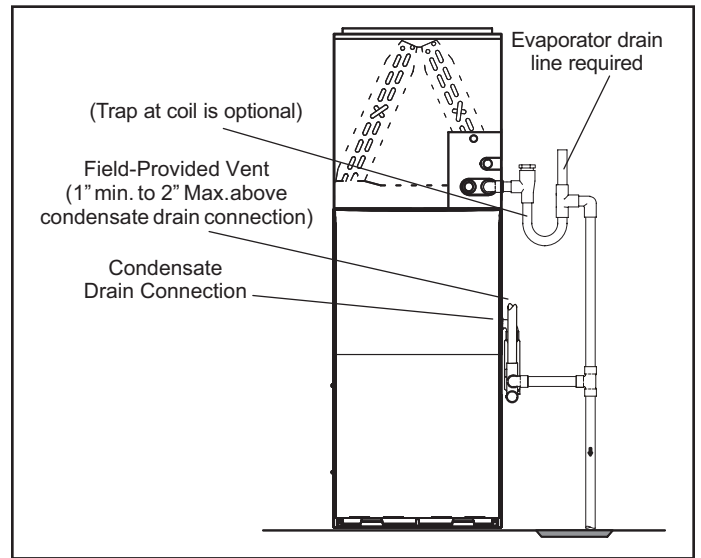
Figure 35. Trap / Drain Assembly Using 1/2" PVC or 3/4" PVC



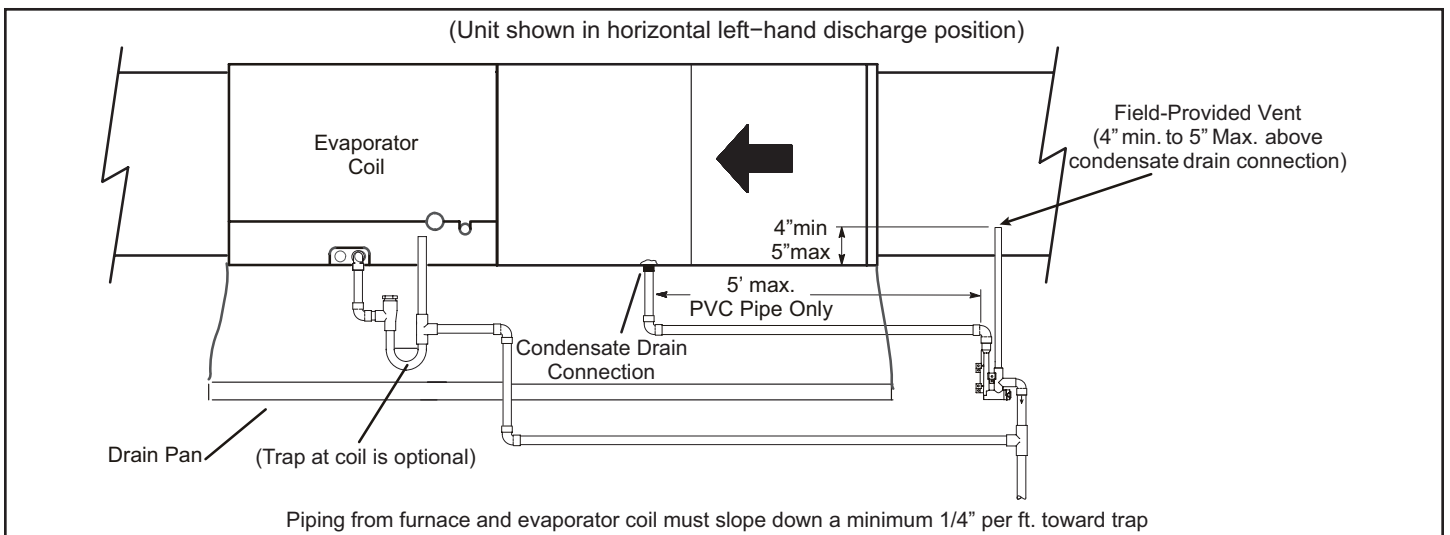
**Figure 36. Furnace with Evaporator Coil Using a Separate Drain**



**Figure 37. Furnace with Evaporator Coil Using a Separate Drain**



**Figure 38. Furnace with Evaporator Coil Using a Common Drain**



**Figure 39. Furnace with Evaporator Coil Using a Common Drain**

## ⚠ IMPORTANT

When combining the furnace and evaporator coil drains together, the A/C condensate drain outlet must be vented to relieve pressure in order for the furnace pressure switch to operate properly.

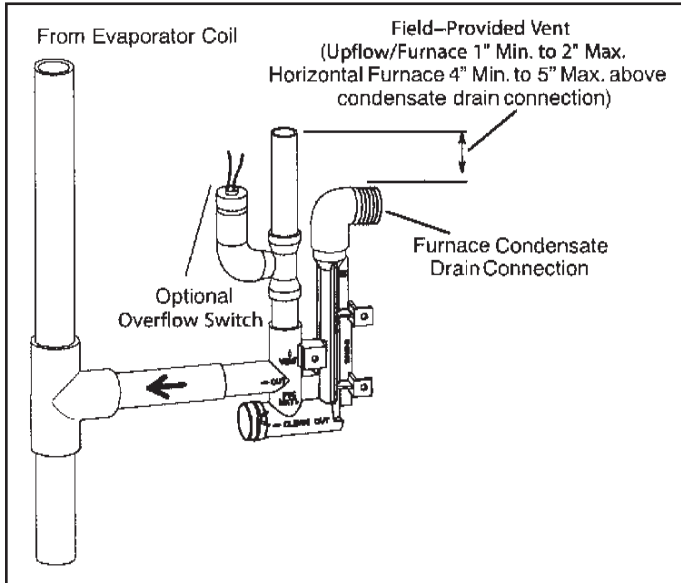


Figure 40. Condensate Trap with Optional Overflow Switch

## Gas Piping

### ⚠ CAUTION

If a flexible gas connector is required or allowed by the authority that has jurisdiction, black iron pipe shall be installed at the gas valve and extend outside the furnace cabinet. The flexible connector can then be added between the black iron pipe and the gas supply line.

### ⚠ WARNING

Do not exceed 600 in.-lbs. (50 ft.-lbs.) torque when attaching the gas piping to the gas valve.

1. Gas piping may be routed into the unit through either the left or right hand side in upflow applications, and either the top or bottom in horizontal applications. Supply piping enters into the gas valve from the side of the valve as shown in Figure 42 and Figure 43.

2. When connecting gas supply, factors such as length of run, number of fittings and furnace rating must be considered to avoid excessive pressure drop. Table 8 lists recommended pipe sizes for typical applications.

**NOTE:** Use two wrenches when connecting gas piping to avoid transferring torque to the manifold.

3. Gas piping must not run in or through air ducts, clothes chutes, chimneys or gas vents, dumb waiters or elevator shafts. Center gas line through piping hole. Gas line should not touch side of unit. See Figure 42 and Figure 43.
4. Piping should be sloped 1/4 " per 15 feet (6 mm per 5.6 m) upward toward the gas meter from the furnace. The piping must be supported at proper intervals, every 8 to 10 feet (2.44 to 3.05 m), using suitable hangers or straps. Install a drip leg in vertical pipe runs to serve as a trap for sediment or condensate.
5. A 1/8" N.P.T. plugged tap or pressure post is located on the gas valve to facilitate test gauge connection. See Figure 41.
6. In some localities, codes may require installation of a manual main shut off valve and union (furnished by installer) external to the unit. Union must be of the ground joint type.

### ⚠ WARNING

Compounds used on threaded joints of gas piping must be resistant to the actions of liquefied petroleum gases.

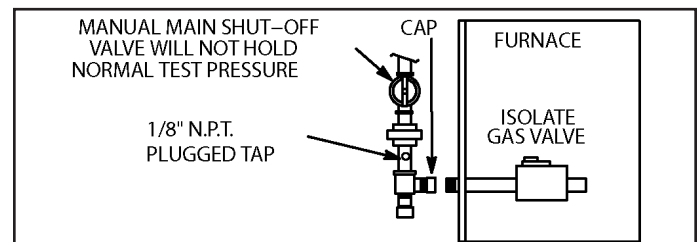


Figure 41.

### Leak Check

After gas piping is completed, carefully check all field-installed piping connections for gas leaks. Use a commercially available leak detecting solution specifically manufactured for leak detection. Never use an open flame to test for gas leaks.

The furnace must be isolated from the gas supply system by closing the individual manual shut-off valve during any gas supply system at pressures greater than or equal to 1/2 psig (3.48 kPa, 14 inches w.c.). This furnace and its components are designed, manufactured and independently certified to comply with all applicable ANSI/CSA standards. A leak check of the furnace and its components is not required.

**Gas Pipe Capacity - FT<sup>3</sup>/HR (kL/HR)**

| Nominal Iron Pipe Size - inches (mm)  | Internal Diameter - inches (mm) | Length or Pipe - feet (m) |                   |                   |                   |                  |                  |                  |                  |                  |                  |
|---|---------------------------------|---------------------------|-------------------|-------------------|-------------------|------------------|------------------|------------------|------------------|------------------|------------------|
|   |                                 | 10 (3.048)                | 20 (6.096)        | 30 (9.144)        | 40 (12.192)       | 50 (15.240)      | 60 (18.288)      | 70 (21.336)      | 80 (24.384)      | 90 (27.432)      | 100 (30.480)     |
| 1/2<br>(12.7)   | .622<br>(17.799)                | 175<br>(4.96)             | 120<br>(3.40)     | 97<br>(2.75)      | 82<br>(2.32)      | 73<br>(2.07)     | 66<br>(1.87)     | 61<br>(1.73)     | 57<br>(1.61)     | 53<br>(1.50)     | 50<br>(1.42)     |
| 3/4<br>(19.05)  | .824<br>(20.930)                | 360<br>(10.19)            | 250<br>(7.08)     | 200<br>(5.66)     | 170<br>(4.81)     | 151<br>(4.28)    | 138<br>(3.91)    | 125<br>(3.54)    | 118<br>(3.34)    | 110<br>(3.11)    | 103<br>(2.92)    |
| 1<br>(25.4)   | 1.049<br>(26.645)               | 680<br>(19.25)            | 465<br>(13.17)    | 375<br>(10.62)    | 320<br>(9.06)     | 285<br>(8.07)    | 260<br>(7.36)    | 240<br>(6.80)    | 220<br>(6.23)    | 205<br>(5.80)    | 195<br>(5.52)    |
| 1-1/4<br>(31.75)  | 1.380<br>(35.052)               | 1400<br>(39.64)           | 950<br>(26.90)    | 770<br>(21.80)    | 660<br>(18.69)    | 580<br>(16.42)   | 530<br>(15.01)   | 490<br>(13.87)   | 460<br>(13.03)   | 430<br>(12.18)   | 400<br>(11.33)   |
| 1-1/2<br>(38.1)   | 1.610<br>(40.894)               | 2100<br>(59.46)           | 460<br>(41.34)    | 1180<br>(33.41)   | 990<br>(28.03)    | 900<br>(25.48)   | 810<br>(22.94)   | 750<br>(21.24)   | 690<br>(19.54)   | 650<br>(18.41)   | 620<br>(17.56)   |
| 2<br>(50.8)   | 2.067<br>(52.502)               | 3950<br>(111.85)          | 2750<br>(77.87)   | 2200<br>(62.30)   | 1900<br>(53.80)   | 1680<br>(47.57)  | 1520<br>(43.04)  | 1400<br>(39.64)  | 1300<br>(36.81)  | 1220<br>(34.55)  | 1150<br>(32.56)  |
| 2-1/2<br>(63.5)   | 2.469<br>(67.713)               | 6300<br>(178.39)          | 4350<br>(123.17)  | 3520<br>(99.67)   | 3000<br>(84.95)   | 2650<br>(75.04)  | 2400<br>(67.96)  | 2250<br>(63.71)  | 2050<br>(58.05)  | 1950<br>(55.22)  | 1850<br>(52.38)  |
| 3<br>(76.2)   | 3.068<br>(77.927)               | 11000<br>(311.48)         | 7700<br>(218.03)  | 6250<br>(176.98)  | 5300<br>(150.07)  | 4750<br>(134.50) | 4300<br>(121.76) | 3900<br>(110.43) | 3700<br>(104.77) | 3450<br>(97.69)  | 3250<br>(92.03)  |
| 4<br>(101.6)  | 4.026<br>(102.260)              | 23000<br>(651.27)         | 15800<br>(447.39) | 12800<br>(362.44) | 10900<br>(308.64) | 9700<br>(274.67) | 9700<br>(274.67) | 8100<br>(229.36) | 7500<br>(212.37) | 7200<br>(203.88) | 6700<br>(189.72) |
| <b>NOTE:</b> Capacity given in cubic feet of gas per hour (kilo liters of gas per hour) and based on 0.60 specific gravity gas. |                                 |                           |                   |                   |                   |                  |                  |                  |                  |                  |                  |

**Table 8.**

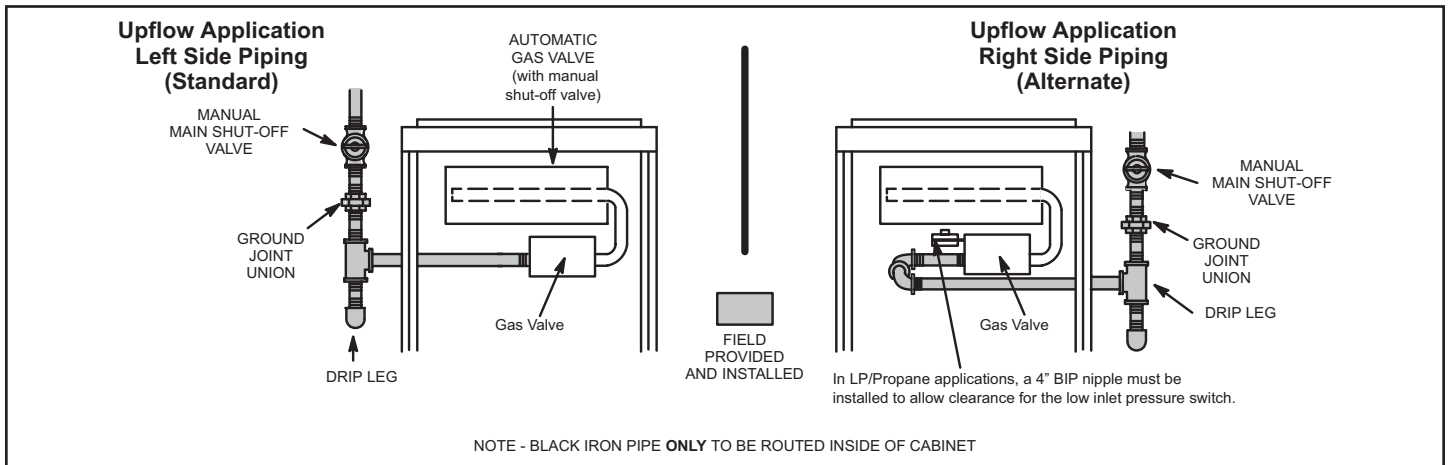
## **⚠ IMPORTANT**

When testing pressure of gas lines, gas valve must be disconnected and isolated. See Figure 41. Gas valves can be damaged if subjected to pressures greater than 1/2 psig (3.48 kPa).

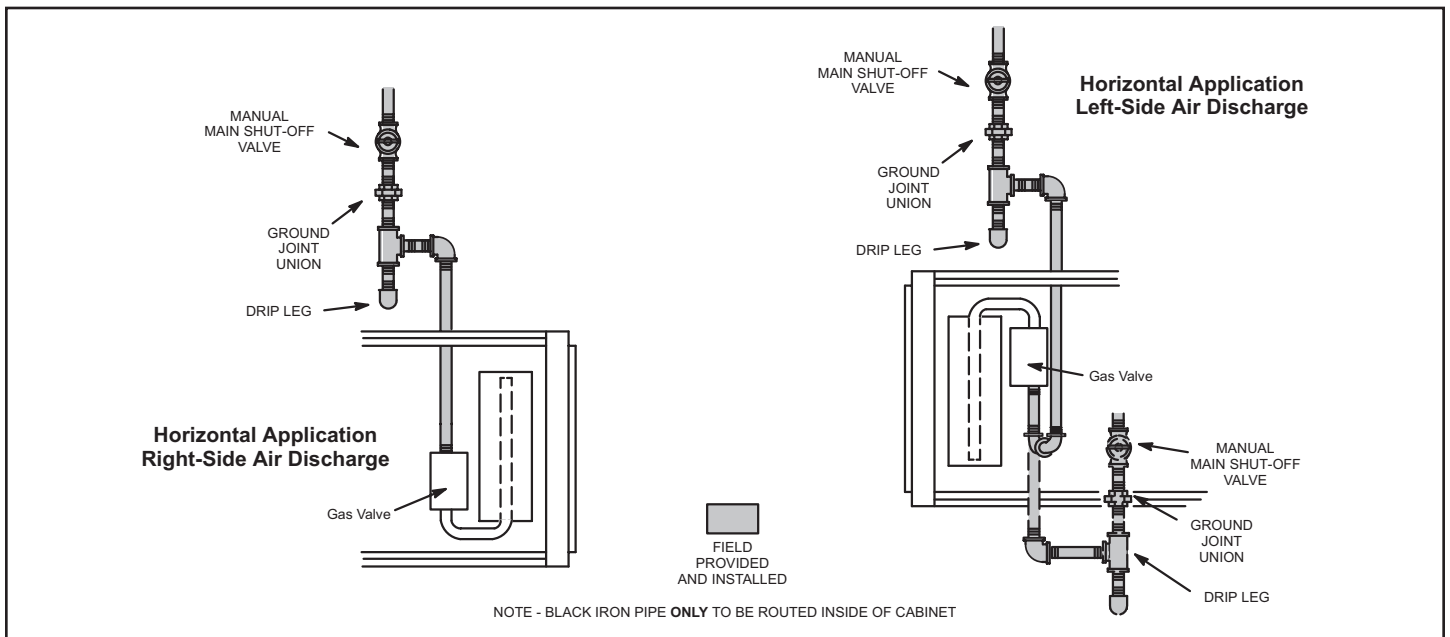
## **⚠ WARNING**

### **FIRE OR EXPLOSION HAZARD**

Failure to follow the safety warnings exactly could result in serious injury, death, or property damage. Never use an open flame to test for gas leaks. Check all connections using a commercially available soap solution made specifically for leak detection. Some soaps used for leak detection are corrosive to certain metals. Carefully rinse piping thoroughly after leak test has been completed.



**Figure 42. Upflow Applications Possible Gas Piping Configurations**



**Figure 43. Horizontal Applications Possible Gas Piping Configurations**

## **⚠ WARNING**

### **CARBON MONOXIDE POISONING HAZARD**

Failure to follow the steps outlined below for each appliance connected to the venting system being placed into operation could result in carbon monoxide poisoning or death.

#### **Removal of the Furnace from Common Vent**

In the event that an existing furnace is removed from a venting system commonly run with separate gas appliances, the venting system is likely to be too large to properly vent the remaining attached appliances.

Conduct the following test while each appliance is operating and the other appliances (which are not operating) remain connected to the common venting system. If the venting system has been installed improperly, you must correct the system as indicated in the general venting requirements section.

The following steps shall be followed for each appliance connected to the venting system being placed into operation, while all other appliances connected to the venting system are not in operation:

1. Seal any unused openings in the common venting system.
2. Inspect the venting system for proper size and horizontal pitch. Determine that there is no blockage, restriction, leakage, corrosion, or other deficiencies which could cause an unsafe condition.
3. Close all building doors and windows and all doors between the space in which the appliances remaining connected to the common venting system are located and other spaces of the building. Turn ON clothes dryers and any appliances not connected to the common venting system. Turn ON any exhaust fans, such as range hoods and bathroom exhausts, so they will operate at maximum speed. Do not operate a summer exhaust fan. Close fireplace dampers.
4. Follow the lighting instructions. Turn ON the appliance that is being inspected. Adjust the thermostat so that the appliance operates continuously.
5. After the main burner has operated for 5 minutes, test for leaks of flue gases at the draft hood relief opening. Use the flame of a match or candle.
6. After determining that each appliance connected to the common venting system is venting properly, (step 3) return all doors, windows, exhaust fans, fireplace dampers, and any other gas burning appliances to their previous mode of operation.
7. If a venting problem is found during any of the preceding tests, the common venting system must be modified to correct the problems.

Resize the common venting system to the minimum vent pipe size determined by using the appropriate tables in the current standards of the National Fuel Gas Code ANSI Z223.1.

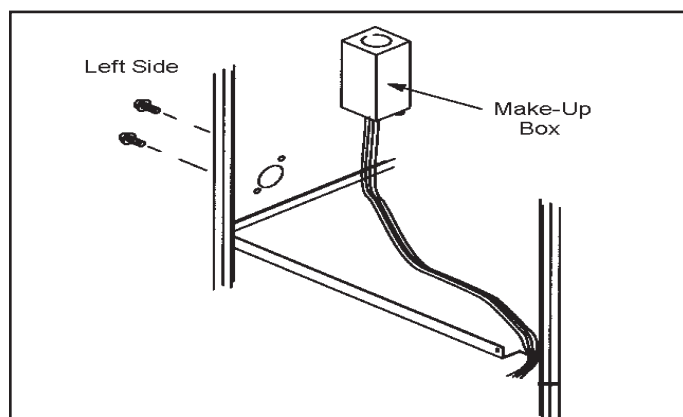
## **Electrical**

### **ELECTROSTATIC DISCHARGE (ESD)**

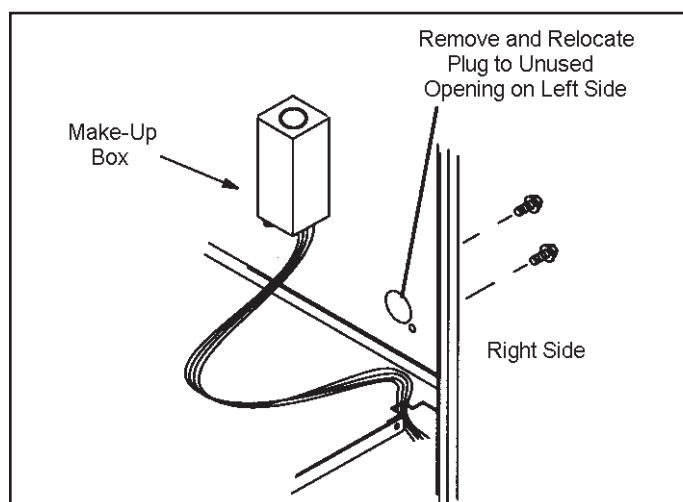
Precautions and Procedures

## **⚠ CAUTION**

Electrostatic discharge can affect electronic components. Take precautions during furnace installation and service to protect the furnace's electronic controls. Precautions will help to avoid control exposure to electrostatic discharge by putting the furnace, the control and the technician at the same electrostatic potential. Neutralize electrostatic charge by touching hand and all tools on an unpainted unit surface, such as the gas valve or blower deck, before performing any service procedure.



**Figure 44. Interior Make-Up Box Installation**



**Figure 45. Interior Make-Up Box Installation**

The unit is equipped with a field makeup box. The makeup box may be moved to the right side of the furnace to facilitate installation. If the makeup box is moved to the right side, clip the wire ties that bundle the wires together. The excess wire must be pulled into the blower compartment. Secure the excess wire to the existing harness to protect it from damage. Seal unused openings on left side with plugs removed from right side.

1. The power supply wiring must meet Class I restrictions. Protected by either a fuse or circuit breaker, select circuit protection and wire size according to unit nameplate.

**NOTE:** Unit nameplate states maximum current draw. See Table 9 for maximum over-current protection.

| Capacity                  | Maximum Over-Current Protection (Amps) |
|---------------------------|--|
| 070*B12, 090*C12, 090*C16 | 15                                     |
| 090*C20, 110*C20, 135*D20 | 20                                     |

**Table 9.**

2. Holes are on both sides of the furnace cabinet to facilitate wiring.
3. Install a separate (properly sized) disconnect switch near the furnace so that power can be turned off for servicing.
4. Before connecting the thermostat, check to make sure the wires will be long enough for servicing at a later date. Make sure that the thermostat wire is long enough to facilitate future removal of blower for service.
5. Complete the wiring connections to the equipment. Use the provided unit wiring diagram and the field wiring information shown in Figure 46 and Table 18. Use 18 gauge wire or larger that is suitable for Class II rating for thermostat connections.
6. Electrically ground the unit according to local codes or, in the absence of local codes, according to the current National Electric Code (ANSI/HFPA No. 70) for the USA and current Canadian Electric Code Part 1 (CSA standard C22.1) for Canada. A green ground wire is provided in the field makeup box.
7. One line voltage “AAC” 1/4” spade terminal is provided on the furnace integrated control. Any electronic air cleaner or other 120V accessory rated up to one amp can be connected to this terminal with the neutral leg of the circuit being connected to one of the provided neutral terminals. See Figure 56 for location of terminal. This terminal is energized when the indoor blower is operating.
8. One line voltage “HUM” 1/4” spade terminal is provided on the furnace integrated control. Any humidifier or other 120V accessory rated up to one amp can be connected to this terminal with the neutral leg of the circuit being connected to one of the provided neutral

terminals. See Figure 56 for location of terminal. This terminal is energized in the heating mode when the indoor blower is operating.

9. One 24V “H” terminal is provided on the furnace integrated control terminal block. Any humidifier rated up to 0.5 amp can be connected to this terminal with the ground leg of the circuit being connected to either ground or the “C” terminal. See Figure 56 for location of terminal.
10. Install the room thermostat according to the instructions provided with the thermostat. See Table 18 for thermostat connections. If the furnace is being matched with a heat pump, refer to the instruction packaged with the dual fuel thermostat.

| Wire Run Length          | AWG# | Insulation / Core Typs   |
|--------------------------|------|--|
| Less than 100'<br>(30 m) | 18   | Color coded, temperature rating 95°F (35°C) minimum, solid core. (Class II Rated Wiring) |
| More than 100'<br>(30 m) | 16   |  |

**Table 10. Run Length - Non-Communicating**

### Thermostat Selection

A Comfort Sync thermostat must be used in communicating applications. Refer to the instructions provided with the thermostat for installation, set-up and operation.

This unit is designed to operate in a variable rate capacity mode using a two-stage thermostat. This unit will automatically adjust firing rate based upon thermostat cycle times.

For optimal performance, use a high quality electronic digital thermostat or any other with adjustable settings for 1st stage / 2nd stage on / off differentials and adjustable stage timers.

The following is a two-stage thermostat setup for optimal variable rate capacity mode:

First heat stage differential set to 1/2 to 1° F; second heat stage differential set to 1/2 or 1° F; second heat stage upstage timer disabled, or set to maximum (1 hr. minimum).

### Indoor Blower Speeds

1. When the thermostat is set to “FAN ON”, the indoor blower will run continuously at a percentage of the second stage cooling speed when there is no cooling or heating demand. See Table 20 for allowable continuous circulation speeds.
2. When the unit is running in the heating mode, the integrated control will automatically adjust the blower speed to match the furnace firing rate. This speed can be adjusted up or down by 7.5% or 15% using DIP switches 14 through 16 for the low heat speed and 17 through 19 for the high heat speed. See Table 19 for allowable heating speeds.

- When there is a cooling demand, the indoor blower will run on the cooling speed designated by the positions of DIP switches 8 through 11.

### Generator Use - Voltage Requirements

The following requirements must be kept in mind when specifying a generator for use with this equipment:

- The furnace requires 120 volts  $\pm$  10% (Range: 108 volts to 132 volts).
- The furnace operates at 60 Hz  $\pm$  5% (Range: 57 Hz to 63 Hz).
- The furnace integrated control requires both polarity and proper ground. Both polarity and proper grounding should be checked before attempting to operate the furnace on either permanent or temporary power.
- Generator should have a wave form distortion of less than 5% THD (Total Harmonic Distortion).

These units are equipped with an integrated control. This control manages ignition timing, combustion air inducer speed, heating mode fan OFF delays and indoor blower speeds based on selections made using the control DIP switches and onboard links. The control includes an internal feature that automatically resets the ignition control when it has been locked out.

**NOTE:** All DIP switches are factory shipped in the "OFF" position.

### Heating Operation DIP Switch Settings

See Figure 56

**Switch 1 - Thermostat Selection** - This unit may be used with either a single stage or two stage thermostat. The thermostat selection is made using a DIP switch, which must be properly positioned for the particular application. The DIP switch is factory positioned for use with a two stage thermostat. If a single stage thermostat is to be used, the DIP switch must be repositioned. See Table 12.

**Switch 2 - Operating Mode with Two Stage Thermostat** - If a two stage thermostat is used, the furnace can operate in either variable capacity or conventional two stage mode. When variable capacity mode is selected, the firing rate of

the unit is varied to maximize comfort. Conventional two stage mode is the factory default setting. See Table 12.

**Switch 3 - Second Stage Heat On Delay** - If a single stage thermostat is used, the integrated control can be used to energize second stage heat after either 7 minutes or 12 minutes of first stage heat operation. See Table 12.

**Switches 4 and 5 - Blower Off Delay** - The blower On delay of 30 seconds is not adjustable. The blower Off delay (time that the blower operates after the heating demand has been satisfied) can be adjusted by moving switches 4 and 5 on the integrated control. The unit is shipped from the factory with a blower Off delay of 90 seconds. The blower Off delay affects comfort and is adjustable to satisfy individual applications. Adjust the blower Off delay to achieve a supply air temperature between 90° and 110° F at the exact moment that the blower is deenergized. Longer Off delay settings provide lower supply air temperatures; shorter settings provide higher supply air temperatures. Table 11 provides the blower Off timings that will result from different switch settings.

| Blower Off Delay (Seconds) | Switch 4 | Switch 5 |
|----------------------------|----------|----------|
| 60                         | Off      | On       |
| 90 (factory)               | Off      | Off      |
| 120                        | On       | Off      |
| 180                        | On       | On       |

Table 11. Blower Off Delay Switch Settings

### Indoor Blower Operation DIP Switch Settings

**Switches 6 and 7 - Continuous Indoor Fan Operation - Blower Speed** - The unit is shipped from the factory with the DIP switches positioned for medium low (38%) speed during continuous indoor blower operation. Continuous fan setting is 38% of cool setting and is not adjustable.

**Switches 8 and 9 - Cooling Mode Blower Speed** - The unit is shipped from the factory with the DIP switches positioned for high speed (4) indoor blower motor operation during the cooling mode. Table 13 provides the cooling mode blower speeds that will result from different switch settings.

| Operation                            | Thermostat   | Switch 1 | Switch 2 | Switch 3   |
|--------------------------------------|--------------|----------|----------|--|
| Variable Capacity Heat (35% to 100%) | Two-Stage    | OFF      | ON       | OFF  |
| Three Stage Heat (35%, 70%, 100%)    | Single-Stage | ON       | OFF      | 2nd stage delay<br>OFF = 7 minutes<br>ON = 12 minutes<br>3rd stage delay<br>10 minutes fixed |
| Two Stage Heat (W1 70%, W2 100%)     | Two-Stage    | OFF      | OFF      | OFF  |

Table 12. Thermostat Selection Switch Settings



| Speed              | Switch 8 | Switch 9 |
|--------------------|----------|----------|
| 1 - Low            | On       | On       |
| 2 - Medium Low     | Off      | On       |
| 3 - Medium High    | On       | Off      |
| 4 - High (factory) | Off      | Off      |

**Table 13. Cooling Mode Blower Speeds**

**Switches 10 and 11 - Cooling Mode Blower Speed Adjustment** - The unit is shipped from the factory with the DIP switches positioned for NORMAL (no) adjustment. The DIP switches may be positioned to adjust the blower speed by +10% or -10% to better suit the application. Table 14 provides blower speed adjustments that will result from different switch settings. Refer to air flow tables for values.

With switches 10 and 11 set to ON, motor will bypass ramping profiles and all delays and will immediately run at selected COOLING speed upon a call for cool. LED will continue to operate as normal. This mode is used to check motor operation.

| Adjustment       | Switch 10 | Switch 11 |
|------------------|-----------|-----------|
| + 10%            | On        | Off       |
| NORMAL (factory) | Off       | Off       |
| - 10% (approx.)  | Off       | On        |
| MOTOR TEST       | On        | On        |

**Table 14. Cooling Mode Blower Speed Adjustment**

**Switches 12 and 13 - Cooling Mode Blower Speed Ramping** - Blower speed ramping may be used to enhance dehumidification performance. The switches are factory set at option A, which has the greatest effect on blower motor performance. Table 15 provides the cooling mode blower speed ramping options that will result from different switch settings. The cooling mode blower speed ramping options are detailed below.

**NOTE:** The OFF portion of the selected ramp profile only applies during heat pump operation in dual fuel applications.

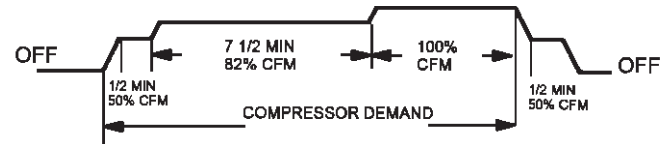
| Ramping Option | Switch 12 | Switch 13 |
|----------------|-----------|-----------|
| A (factory)    | Off       | Off       |
| B              | On        | Off       |
| C              | Off       | On        |
| D              | On        | On        |

**Table 15. Cooling Mode Blower Speed Ramping**

**Ramping Option “A” (Factory Selection)**

- Motor runs at 50% for 30 seconds.
- Motor then runs at 82% for approximately 7-1/2 minutes.
- If demand has not been satisfied after 7-1/2 minutes, motor runs at 100% until demand is satisfied.

- Once demand is met, motor runs at 50% for 30 seconds then ramps down to stop.



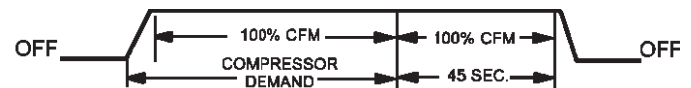
**Ramping Option “B”**

- Motor runs at 82% for approximately 7-1/2 minutes. If demand has not been satisfied after 7-1/2 minutes, motor runs at 100% until demand is satisfied.
- Once demand is met, motor ramps down to stop.



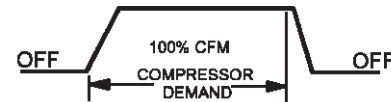
**Ramping Option “C”**

- Motor runs at 100% until demand is satisfied.
- Once demand is met, motor runs at 100% for 45 seconds then ramps down to stop.



**Ramping Option “D”**

- Motor runs at 100% until demand is satisfied.
- Once demand is met, motor ramps down to stop.



**Switches 14 through 19 - Heating Mode Blower Speed**

- These switches are factory set at the OFF position, which provides 100% of normal speed during HIGH HEAT demand, 70% of normal speed during MIDRANGE HEAT demand and 35% of normal speed during LOW HEAT demand. Switches 14, 15 and 16 are used to adjust the LOW HEAT blower motor speed. Switches 17, 18 and 19 are used to adjust the HIGH HEAT blower motor speed. Table 16 and Table 17 provide the heating mode blower speeds that will result from different switch settings. See Table 19 for allowable heating speeds.

| Thermostat Demand  | Blower Speed Adjustments | DIP Switch Settings |     |     |
|--------------------|--------------------------|---------------------|-----|-----|
|                    |                          | 14                  | 15  | 16  |
| Low Heat (R to W1) | + 15%                    | On                  | Off | On  |
|                    | + 7.5%                   | On                  | Off | Off |
|                    | Normal                   | Off                 | Off | Off |
|                    | - 7.5%                   | On                  | On  | Off |
|                    | - 15%                    | On                  | On  | On  |

**Table 16. Low Heat Blower Speeds**

| Thermostat Demand           | Blower Speed Adjustments | DIP Switch Settings |     |     |
|-----------------------------|--------------------------|---------------------|-----|-----|
|                             |                          | 17                  | 18  | 19  |
| High Heat<br>(R to W1 & W2) | + 15%                    | On                  | Off | On  |
|                             | + 7.5%                   | On                  | Off | Off |
|                             | Normal                   | Off                 | Off | Off |
|                             | - 7.5%                   | On                  | On  | Off |
|                             | - 15%                    | On                  | On  | On  |

**Table 17. High Heat Blower Speeds**

### On Board Links

On Board links must be clipped (when applicable) before unit is placed into operation with a non-communicating thermostat.

**On Board Link W914 DS to R** - On Board link W914, is a clippable connection between terminals DS and R on the integrated control. W914 must be cut when installed with a thermostat that features humidity control.

**On Board Link W951 R to O** - On Board link W951 is a clippable connection between terminals R and O on the integrated control. W951 must be cut when the furnace is installed in applications that include a heat pump unit and thermostat that features dual fuel use. If the link is left intact, terminal "O" will remain energized, eliminating the HEAT MODE in the heat pump.

**On Board Link W915 Y1 to Y2** - On Board link W915 is a clippable connection between terminals Y1 and Y2 on the integrated control. W915 must be cut if two stage cooling will be used. If the link is not cut, the outdoor unit will operate in second stage cooling only.

**Diagnostic LED** - The seven segment diagnostic LED displays operating status, target airflow, error codes and other information.

**Diagnostic Push Button** - The diagnostic push button is located adjacent to the seven segment diagnostic LED. This button is used to enable the Error Code Recall mode and the Field Test mode. Press the button and hold it to cycle through a menu of options. Every five seconds a new menu item will be displayed. When the button is released, the displayed item will be selected. Once all items in the menu have been displayed, the menu resumes from the beginning until the button is released.

**Error Code Recall Mode** - Select "E" from the menu to access the most recent 10 error codes. Select "c" from the Error Code Recall menu to clear all error codes. Button must be pressed a second time while "c" is flashing to confirm command to delete codes. Press the button until a solid "-" is displayed to exit the Error Code Recall mode.

**Field Test Mode** - Use the diagnostic push button to scroll through the menu as described above. Release the button when the LED flashes "-" to select the Field Test mode.

While in the Field Test mode the technician can:

- Initiate furnace ignition and move to and hold low-fire rate by applying a R to W1 jumper.
- Initiate furnace ignition sequence and move to and hold high-fire rate by applying a jumper from R to W1 and W2.
- Initiate furnace ignition sequence and move to and hold mid-fire rate by applying a jumper to R and W2.
- Apply then remove the jumper from R to W1 and W2 to change the firing rate from low fire to mid fire and high fire.
- A vent calibration sequence can be initiated even if a thermostat signal is not present. Press and hold the push button until a solid "C" is displayed. Release the button and calibration will begin. The furnace will perform the high-fire and low-fire pressure switch calibrations and display "CAL". After calibration, the LED will return to the flashing "-" display.

During Field Test mode operation, all safety switches are still in the circuit (they are not by-passed) and indoor blower performance and timings will match DIP switch selections. Current furnace firing rate, indoor blower CFM and flame signal will be displayed. To exit the Field Test mode, press and hold the button. The menu will resume from the beginning. Also, cycle the main power to exit the Field Test mode. The integrated control will automatically exit the Field Test mode after 45 minutes of operation.

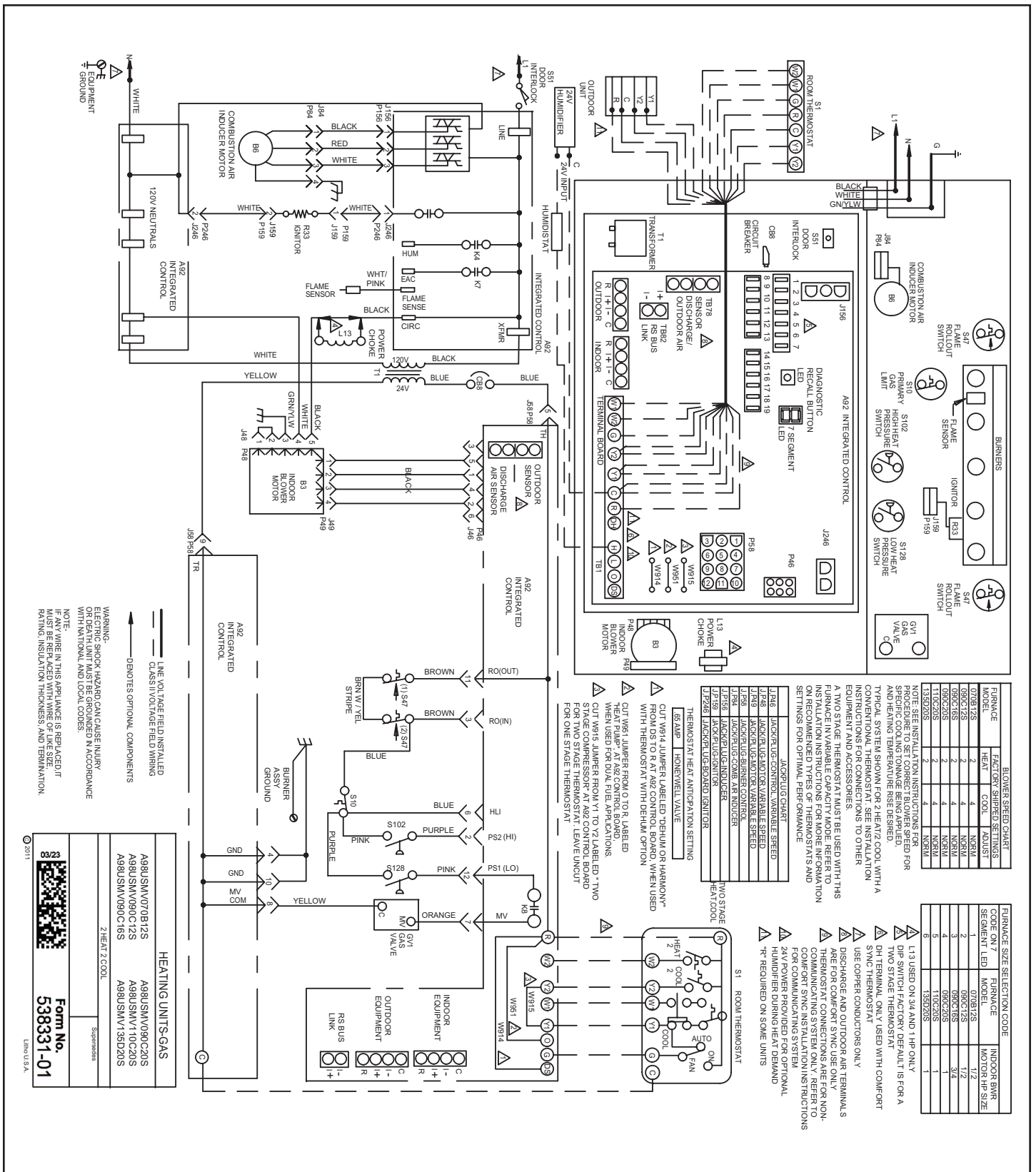


Figure 46. Typical Field Wiring Diagram for Standard Non-Communicating Thermostat

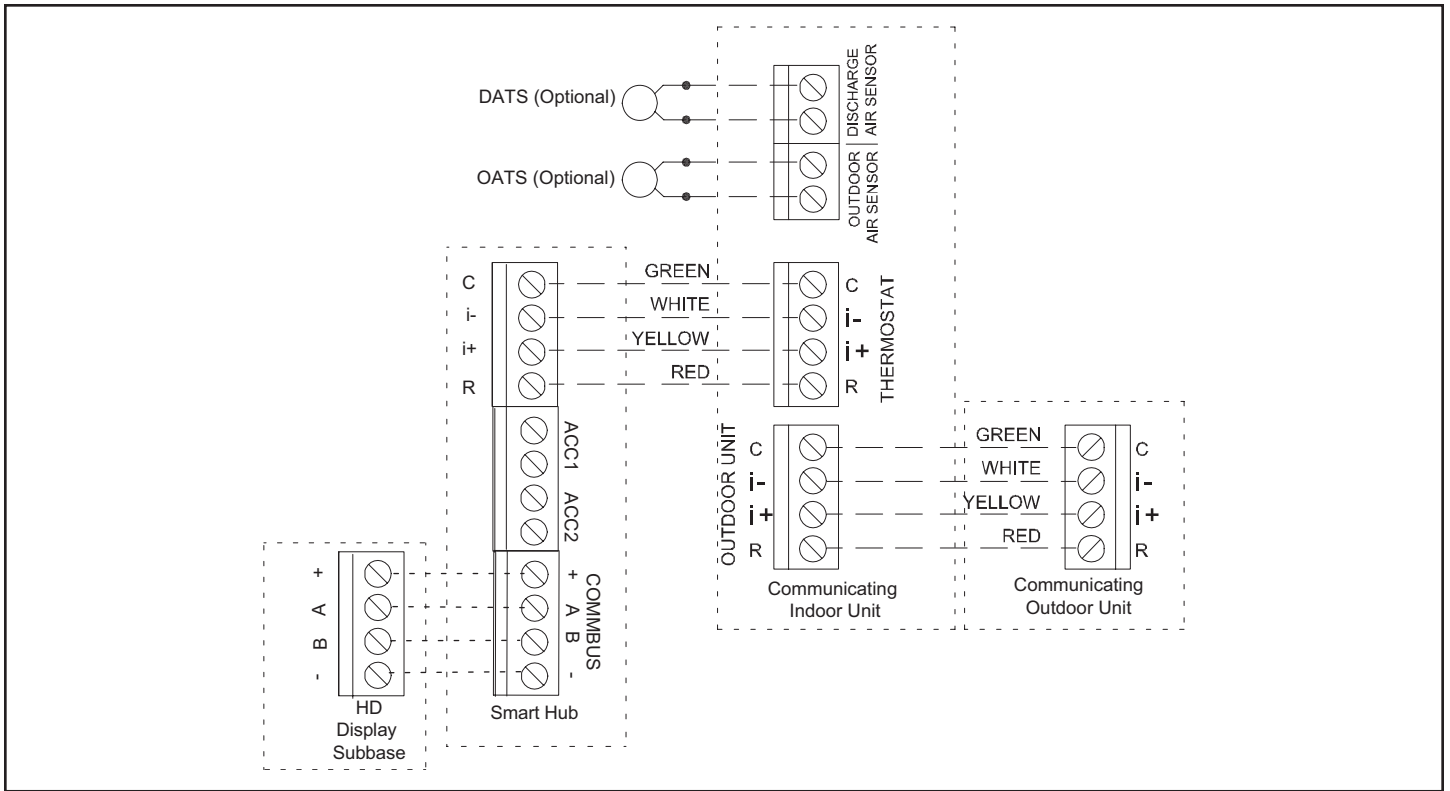


Figure 47. Comfort Sync A3 with Communicating Indoor and Outdoor Units

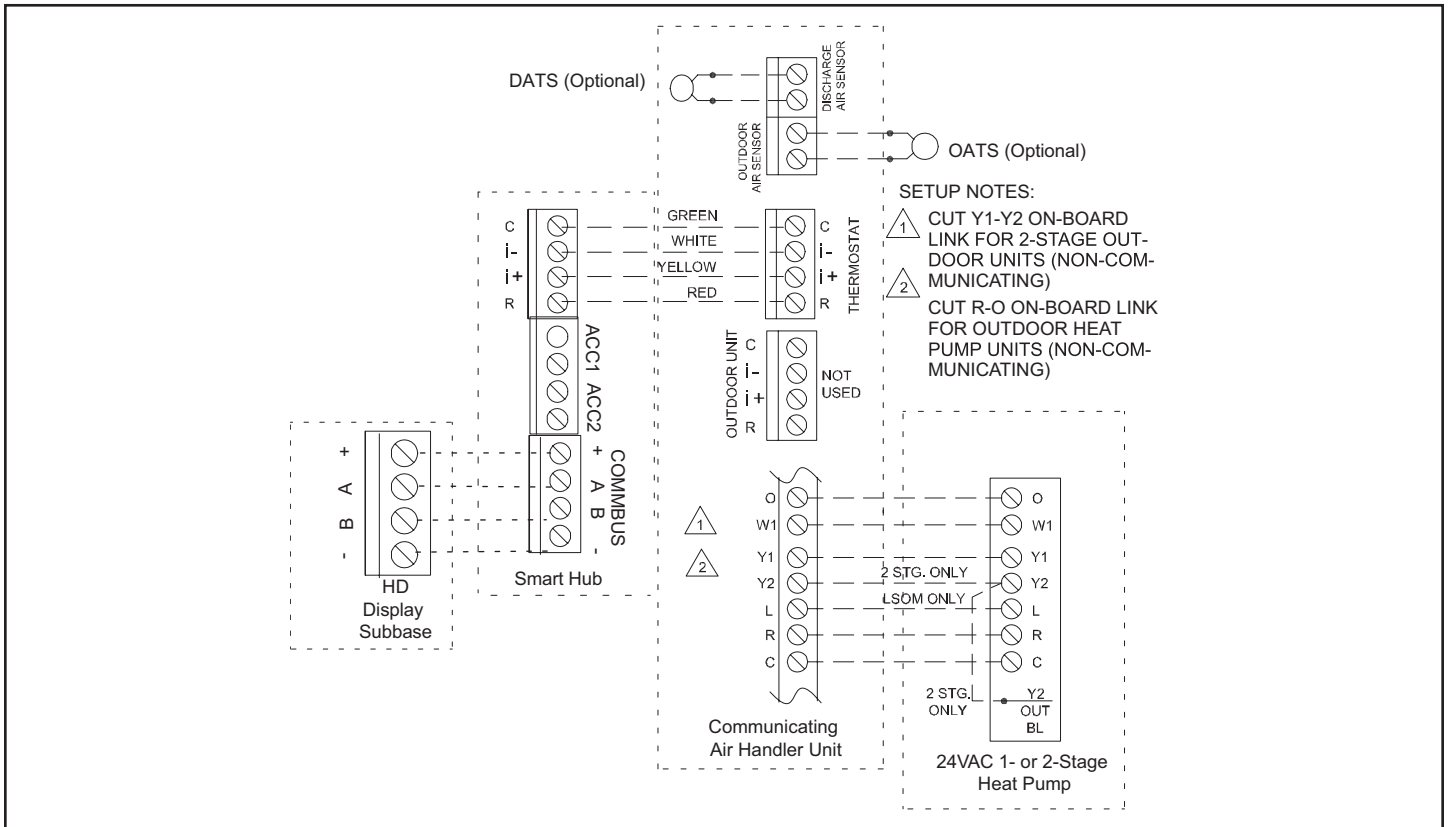
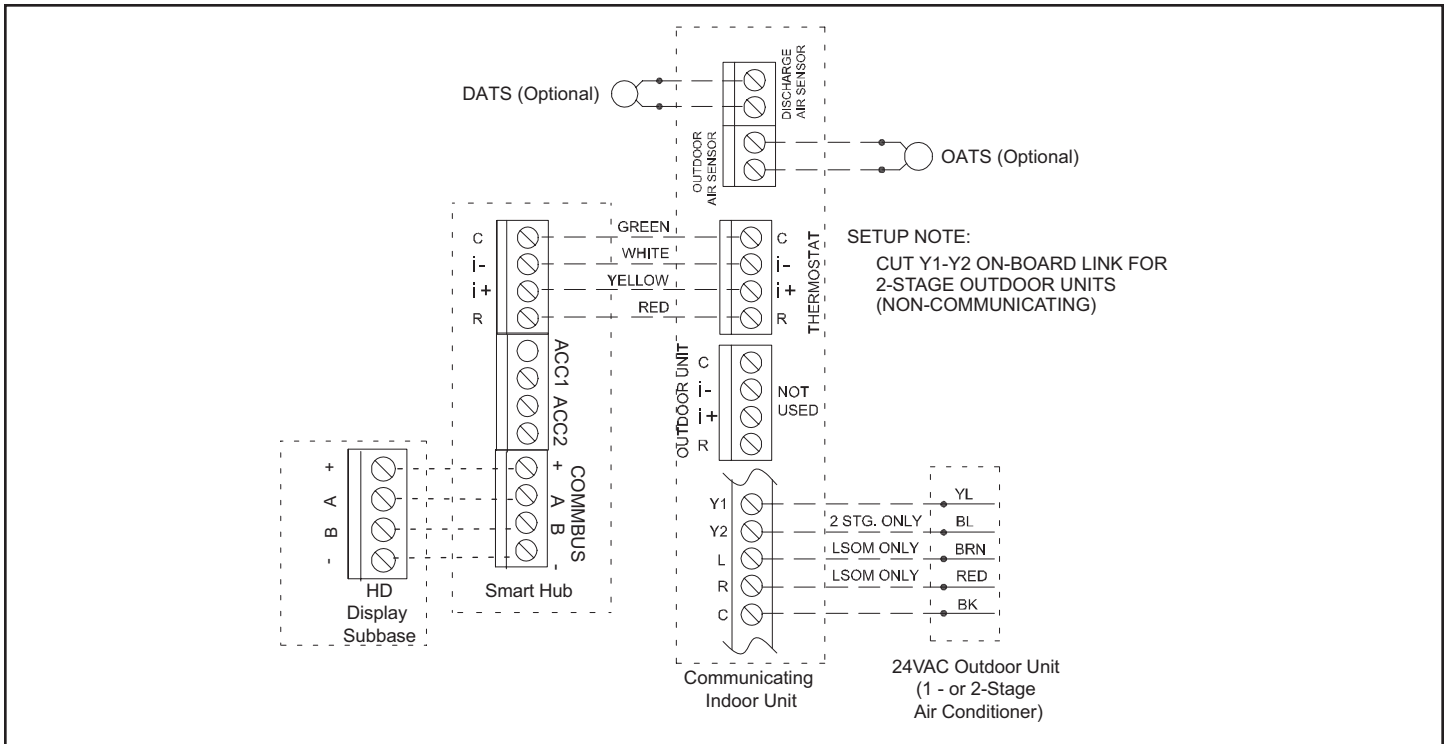
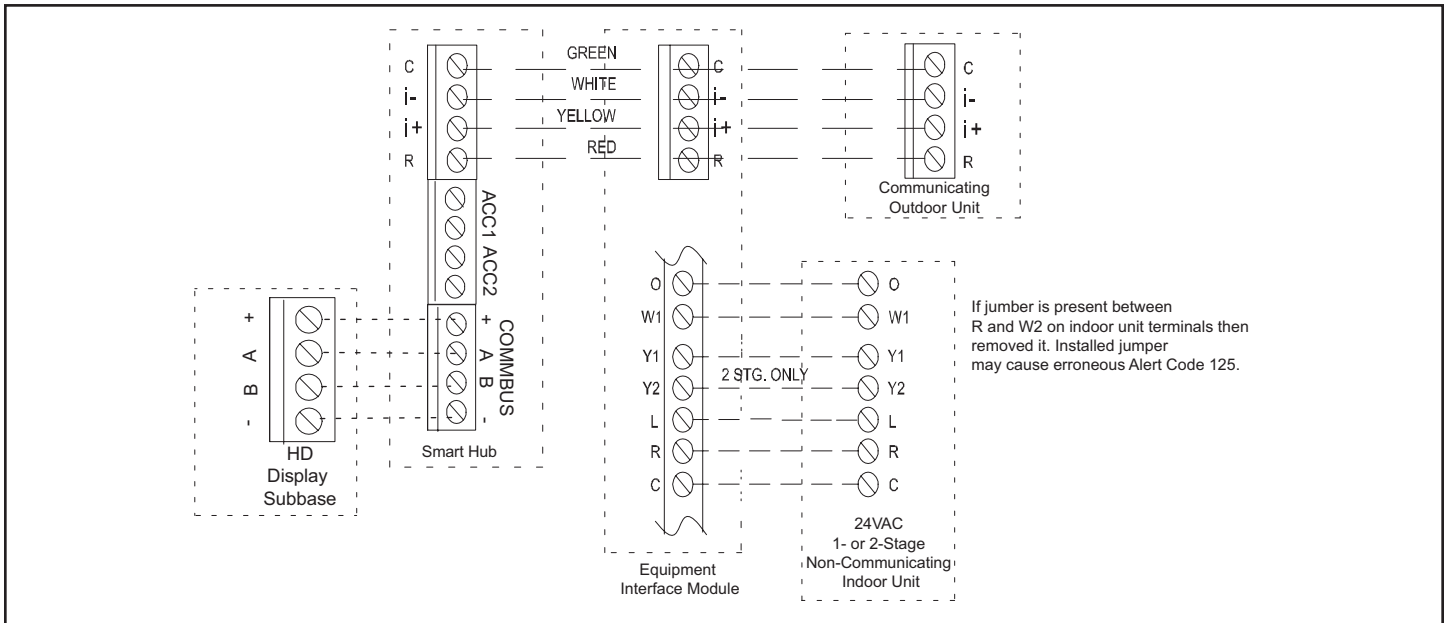


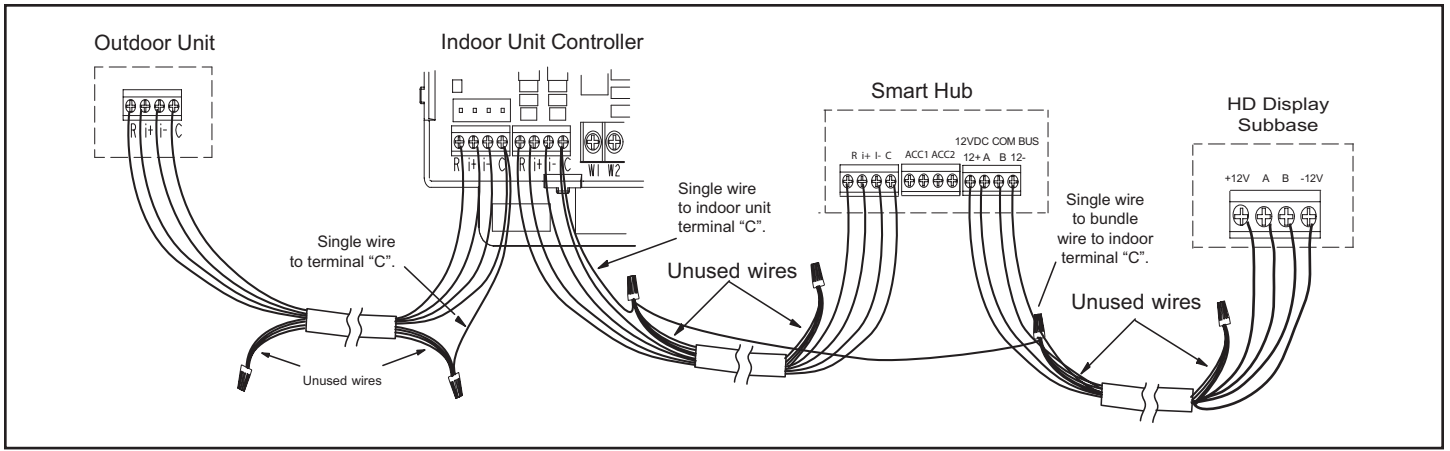
Figure 48. Comfort Sync A3, Communicating Air Handler with 24VAC 1 or 2-Stage Heat Pump



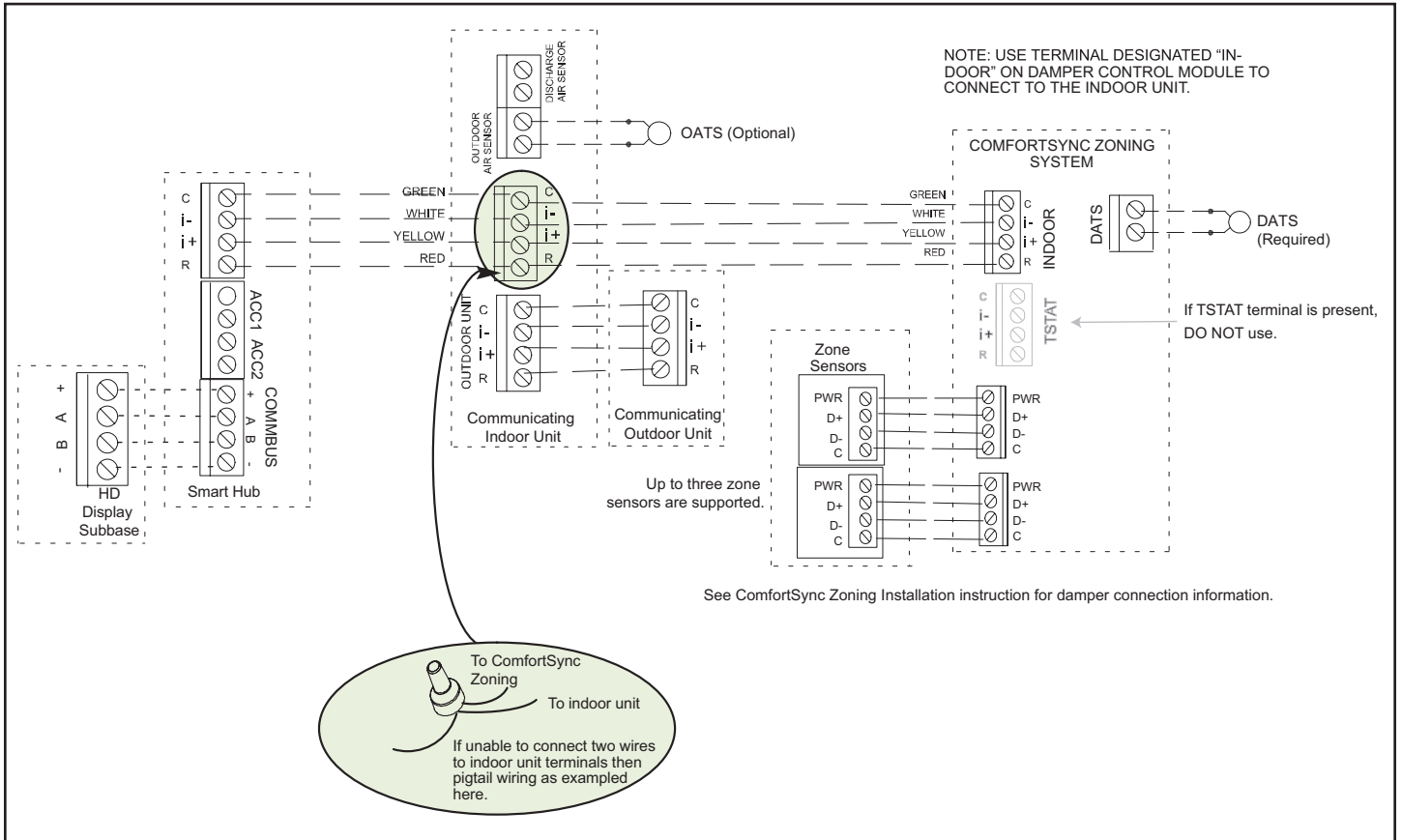
**Figure 49. Comfort Sync A3, Communicating Indoor Unit with 24VAC Air Conditioner**



**Figure 50. Comfort Sync A3 with Equipment Interface Module (EIM), 24VAC Indoor Unit and Communicating Outdoor Unit**



**Figure 51. Wire Termination in Communicating Systems (Electrical Noise) - Typical**



**Figure 52. Comfort Sync A3, Communicating Indoor and Outdoor Units, Comfort Sync Zoning (Damper Control Module) and Zone Sensors**

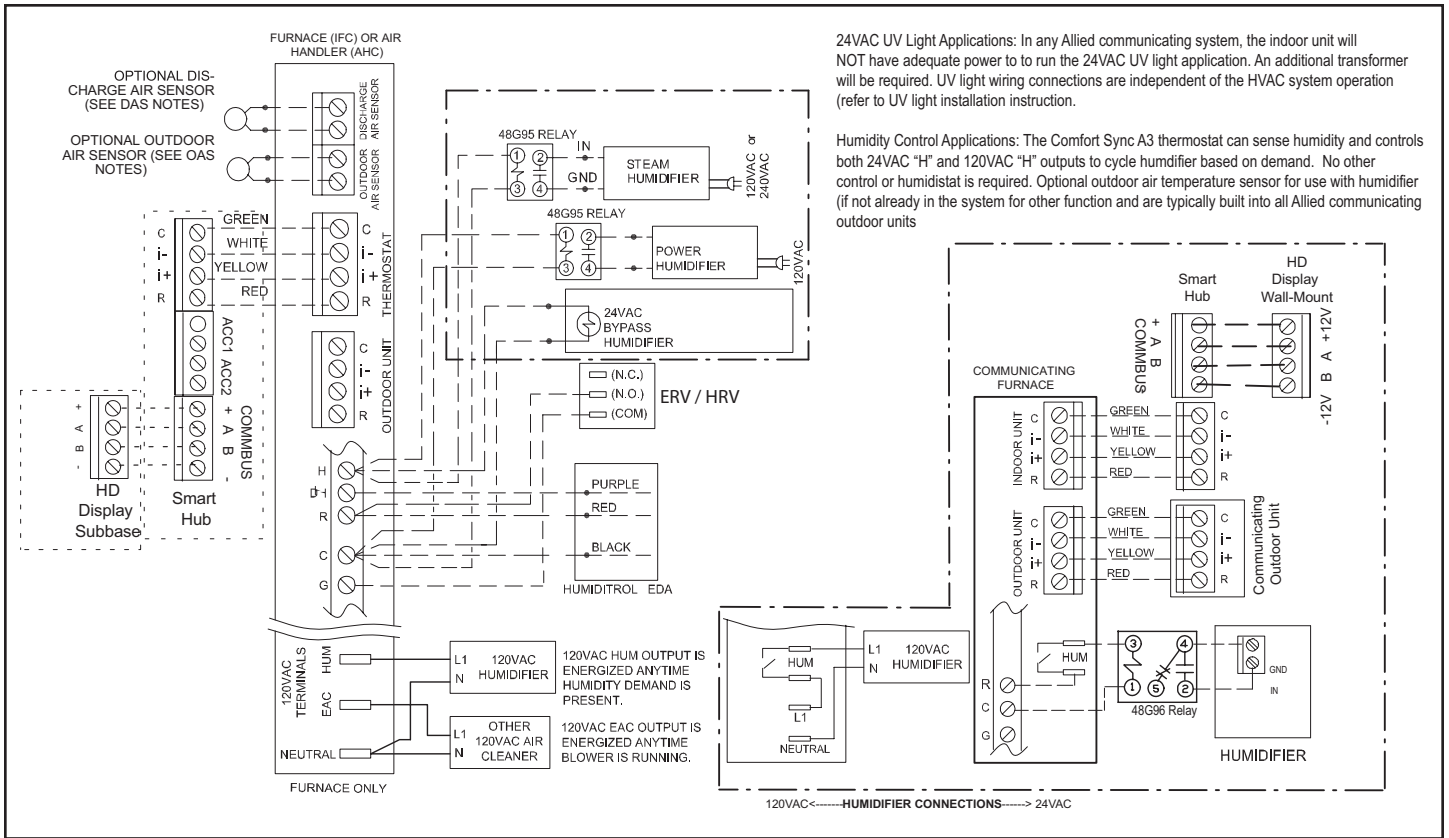


Figure 53. Comfort Sync A3 with Humidifier Accessory

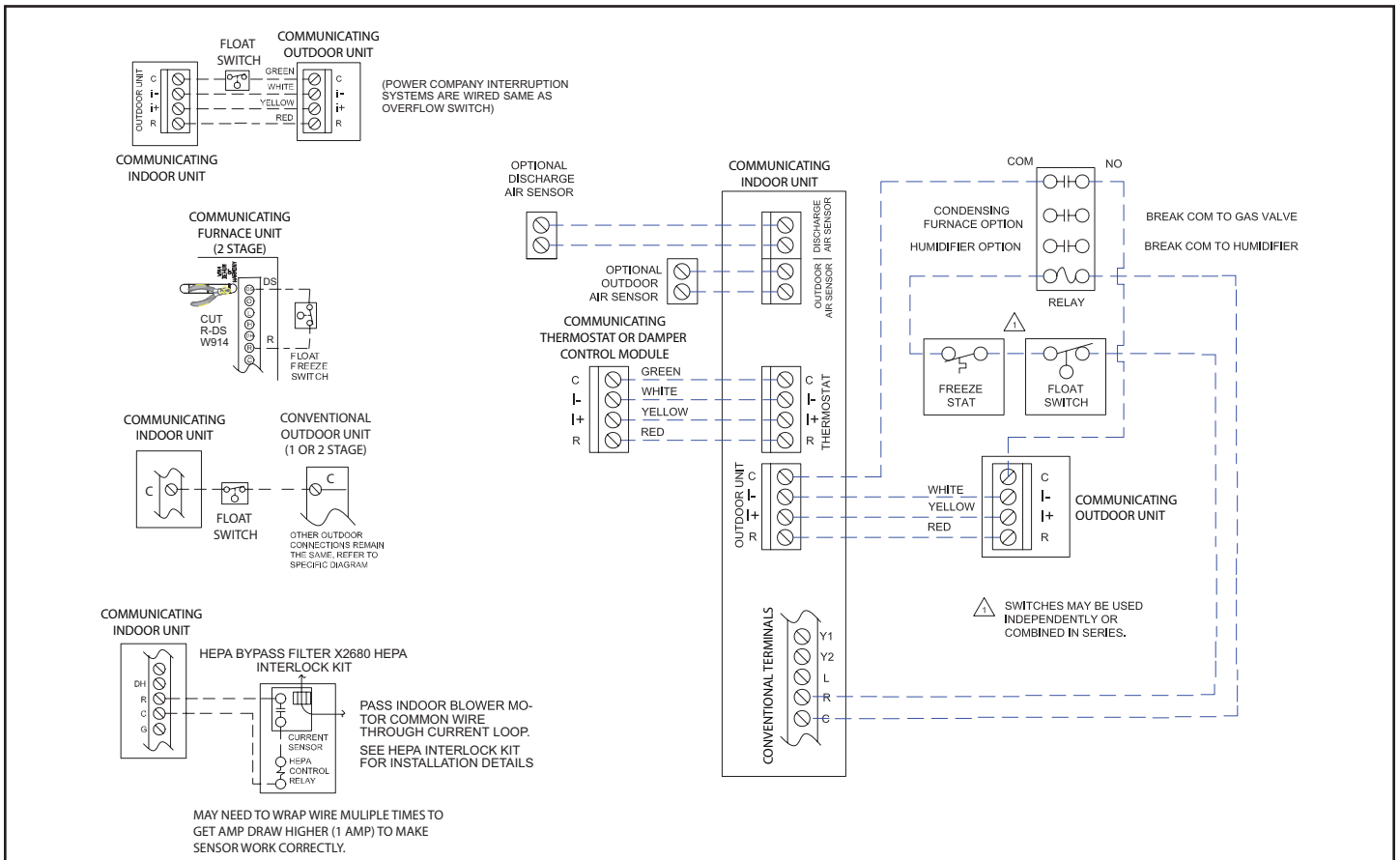
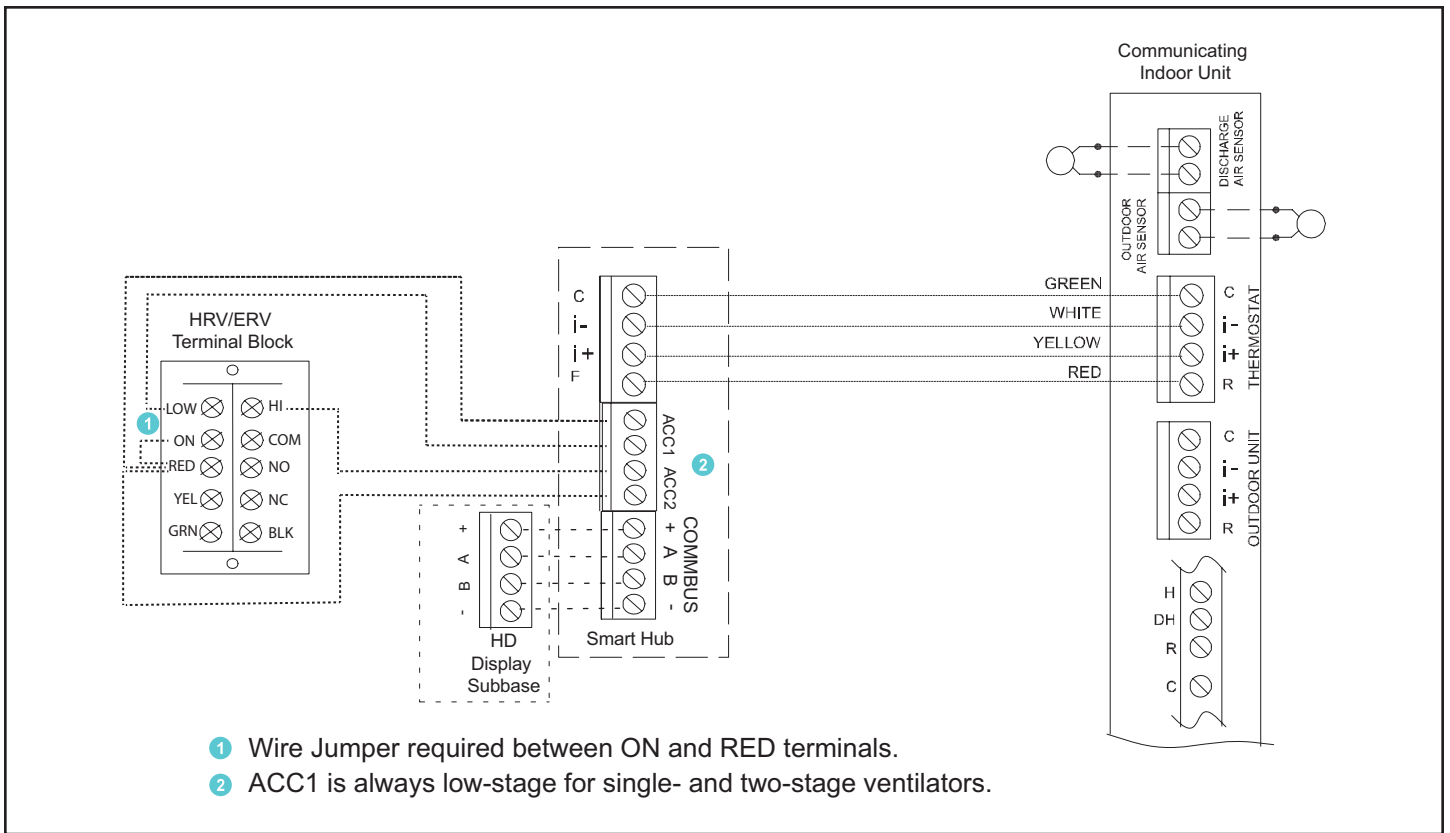
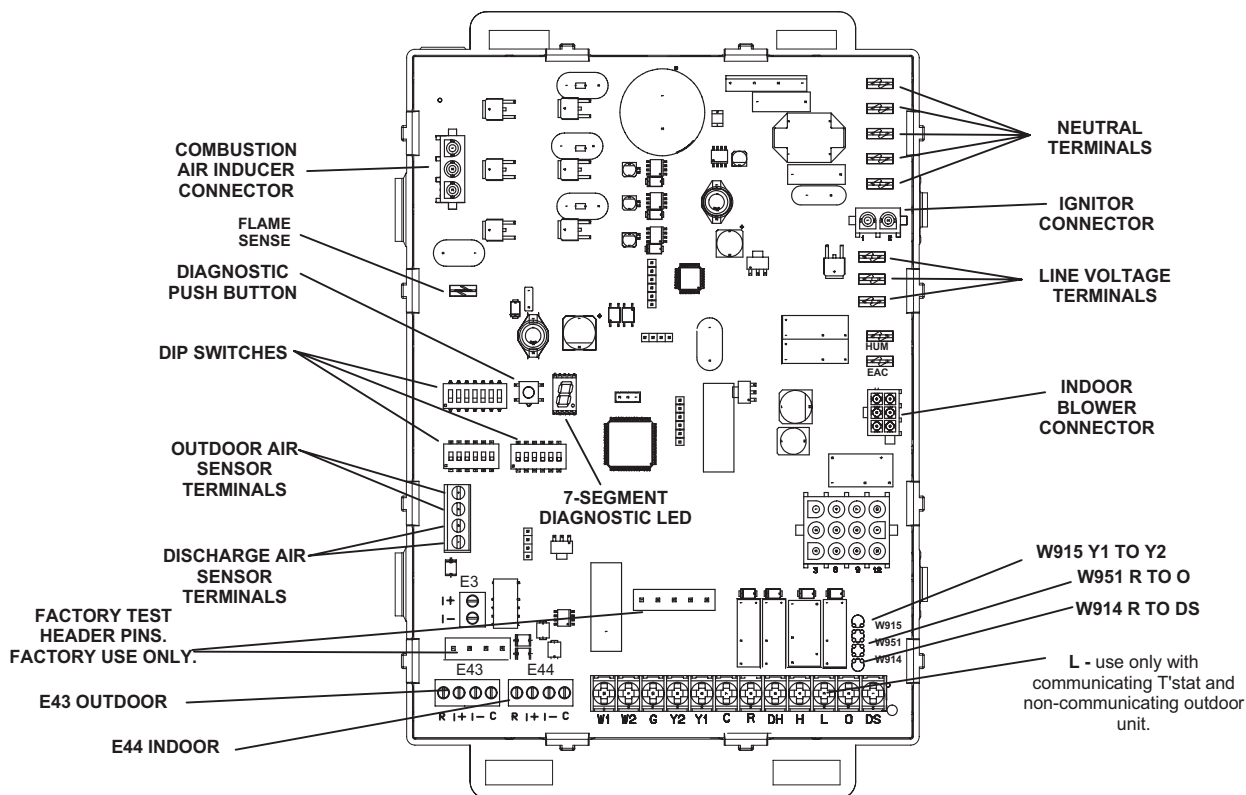


Figure 54. Installing Comfort Sync A3, Communicating Indoor Unit, Float Switch, HEPA Bypass Filter Interlock Kit, Humidifier, Relay and FreezeStat



**Figure 55. Comfort Sync A3 with Ventilation (Fresh Air Damper, ERV and HRV)**





**RS-BUS LINK (E3, future use)**

I + = DATA HIGH CONNECTION  
I - = DATA LOW CONNECTION

**RS-BUS OUTDOOR (E43)**

R = 24VAC  
I + = DATA HIGH CONNECTION  
I - = DATA LOW CONNECTION  
C = 24VAXC COMMON

**RS-BUS INDOOR (E44)**

R = 24VAC  
I + = DATA HIGH CONNECTION  
I - = DATA LOW CONNECTION  
C = 24VAXC COMMON

**1/4" QUICK CONNECT TERMINALS**

HUM = 120 VAC OUTPUT TO HUMIDIFIER  
XMFR = 120 VAC OUTPUT TO TRANSFORMER  
LI = 120 VAC INPUT TO CONTROL  
CIRC = 120 VAC OUTPUT TO CIRCULATING BLOWER  
EAC = 120 VAC OUTPUT TO ELECTRICAL AIR CLEANER  
NEUTRALS = 120 VAC NEUTRAL

**THERMOSTAT CONNECTIONS (E7)**

DS = DEHUMIDIFICATION SIGNAL  
W2 = HEAT DEMAND FROM 2ND STAGE T/STAT  
W1 = HEAT DEMAND FROM 1ST STAGE T/STAT  
R = CLASS 2 VOLTAGE TO THERMOSTAT  
G = MANUAL FAN FROM THERMOSTAT  
C = THERMOSTAT SIGNAL GROUNDCONNECTED TO TRANSFORMER GRD (TR) & CHASIS GROUND (GRD)  
Y1 = THERMOSTAT 1ST STAGE COOL SIGNAL  
Y2 = THERMOSTAT 2ND STAGE COOL SIGNAL  
O = THERMOSTAT SIGNAL TO HEAT PUMP REVERSING VALVE  
H = 24V HUMIDIFIER OUTPUT. DO NOT CONNECT TO COMFORT SYNC® THERMOSTAT  
L = USE ONLY WITH A COMMUNICATING THERMOSTAT AND A NON-COMMUNICATING OUTDOOR UNIT  
DH = DEHUMIDIFICATION OUTPUT COMMUNICATING THERMOSTAT ONLY

**Figure 56. Integrated Control**

| Thermostat  | DIP Switch Settings and On-Board Links |  |                                       | Wiring Connections |                               |
|---|--|--|---------------------------------------|--------------------|-------------------------------|
|   | DIP Switch 1                           | W915<br>(Y1 to Y2)<br>Two-Stage<br>Cooling | W914<br>(DS to R)<br>Dehumidification |                    | W951<br>(Oto R)<br>Heat Pumps |
| <b>1 Heat / 1 Cool</b><br><b>NOTE:</b> Use DIP switch 3 to set second-stage heat ON delay.<br>OFF - 7 minutes<br>ON - 12 minutes  | ON                                     | Intact                                     | Intact                                | Intact             |                               |
| <b>1 Heat / 2 Cool</b><br><b>NOTE:</b> Use DIP switch 3 to set second-stage heat ON delay.<br>OFF - 7 minutes<br>ON - 12 minutes  | ON                                     | Cut  | Intact                                | Intact             |                               |
| <b>1 Heat / 2 Cool with t'stat with dehumidification mode</b><br><b>NOTE:</b> Use DIP switch 3 to set second-stage heat ON delay.<br>OFF - 7 minutes<br>ON - 12 minutes | ON                                     | Cut  | Cut                                   | Intact             |                               |

NOTE - Do NOT make a wire connection between the room thermostat L terminal and the L terminal of the integrated control.

**Table 18. Field Wiring for Non-Communicating Thermostat Applications**

| Thermostat  | DIP Switch Settings and On-Board Links |  |                                       | Wiring Connections |  |
|---|--|--|---------------------------------------|--------------------|--|
|   | DIP Switch 1                           | W915<br>(Y1 to Y2)<br>Two-Stage<br>Cooling | W914<br>(DS to R)<br>Dehumidification |                    | W951<br>(Oto R)<br>Heat Pumps              |
| 2 Heat / 2 Cool   | OFF                                    | Cut  | Intact                                | Intact             | <p>*Not required on all units <b>O</b></p> |
| 2 Heat / 2 Cool<br>with t'stat with<br>dehumidification<br>mode | OFF                                    | Cut  | Cut                                   | Intact             | <p>*Not required on all units <b>O</b></p> |
| 2 Heat / 1 Cool   | OFF                                    | Intact                                     | Intact                                | Intact             | <p>*Not required on all units <b>O</b></p> |

NOTE - Do NOT make a wire connection between the room thermostat L terminal and the L terminal of the integrated control.

**Table 18. Field Wiring for Non-Communicating Thermostat Applications**

| Thermostat  | DIP Switch Settings and On-Board Links |  |                                       | Wiring Connections |                               |
|---|--|--|---------------------------------------|--------------------|-------------------------------|
|   | DIP Switch 1                           | W915<br>(Y1 to Y2)<br>Two-Stage<br>Cooling | W914<br>(DS to R)<br>Dehumidification |                    | W951<br>(Oto R)<br>Heat Pumps |
| <b>Dual Fuel Single-Stage Heat Pump</b><br>Thermostat w/dual fuel capabilities<br>Capable of 2-stage gas heat control | OFF                                    | Intact                                     | Intact                                | Cut                |                               |
| <b>Dual Fuel Two-Stage Heat Pump</b><br>Thermostat w/dual fuel capabilities<br>Capable of 2-stage gas heat control    | OFF                                    | Cut  | Intact                                | Cut                |                               |

NOTE - Do NOT make a wire connection between the room thermostat L terminal and the L terminal of the integrated control.

**Table 18. Field Wiring for Non-Communicating Thermostat Applications**

## Blower Performance

### A98USMV070B12S BLOWER PERFORMANCE (less filter)

#### HEATING BLOWER PERFORMANCE

| Heating Adjust CFM Selections | Heating Input Range and Blower Volume - CFM |     |     |     |     |     |      |      |
|-------------------------------|---|-----|-----|-----|-----|-----|------|------|
|                               | 35%   | 40% | 50% | 60% | 70% | 80% | 90%  | 100% |
| Increase (+15%) Heat CFM      | 489   | 538 | 636 | 735 | 833 | 931 | 1030 | 1128 |
| Increase (+7.5%) Heat CFM     | 450   | 496 | 588 | 680 | 772 | 864 | 956  | 1048 |
| Default Heat CFM              | 410   | 453 | 539 | 624 | 710 | 796 | 881  | 967  |
| Decrease (-7.5%) Heat CFM     | 380   | 419 | 498 | 578 | 657 | 736 | 815  | 895  |
| Decrease (-15%) Heat CFM      | 349   | 385 | 458 | 531 | 604 | 676 | 749  | 822  |

#### COOLING BLOWER PERFORMANCE

| Cooling Adjust CFM Selections | Blower Speed Selections     |            |        |                |                             |            |        |                |
|-------------------------------|-----------------------------|------------|--------|----------------|-----------------------------|------------|--------|----------------|
|                               | First Stage Cool Speed- cfm |            |        |                | Second Stage Cool Speed-cfm |            |        |                |
|                               | Low                         | Medium Low | Medium | High (Default) | Low                         | Medium Low | Medium | High (Default) |
| Increase (+10%) Cool CFM      | 600                         | 740        | 840    | 970            | 860                         | 1060       | 1215   | 1365           |
| Default Cool CFM              | 555                         | 665        | 770    | 855            | 810                         | 960        | 1130   | 1265           |
| Decrease(-10%) Cool CFM       | 500                         | 600        | 680    | 790            | 705                         | 840        | 1005   | 1140           |

### A98USMV090C12S BLOWER PERFORMANCE (less filter)

#### HEATING BLOWER PERFORMANCE

| Heating Adjust CFM Selections | Heating Input Range and Blower Volume - CFM |     |     |     |      |      |      |      |
|-------------------------------|---|-----|-----|-----|------|------|------|------|
|                               | 35%   | 40% | 50% | 60% | 70%  | 80%  | 90%  | 100% |
| Increase (+15%) Heat CFM      | 687   | 734 | 827 | 821 | 1014 | 1108 | 1201 | 1295 |
| Increase (+7.5%) Heat CFM     | 654   | 697 | 792 | 867 | 953  | 1038 | 1123 | 1209 |
| Default Heat CFM              | 621   | 660 | 737 | 814 | 891  | 968  | 1045 | 1122 |
| Decrease (-7.5%) Heat CFM     | 581   | 616 | 687 | 757 | 828  | 899  | 970  | 1041 |
| Decrease (-15%) Heat CFM      | 540   | 572 | 637 | 701 | 788  | 830  | 895  | 959  |

#### COOLING BLOWER PERFORMANCE

| Cooling Adjust CFM Selections | Blower Speed Selections     |            |        |                |                             |            |        |                |
|-------------------------------|-----------------------------|------------|--------|----------------|-----------------------------|------------|--------|----------------|
|                               | First Stage Cool Speed- cfm |            |        |                | Second Stage Cool Speed-cfm |            |        |                |
|                               | Low                         | Medium Low | Medium | High (Default) | Low                         | Medium Low | Medium | High (Default) |
| Increase (+10%) Cool CFM      | 625                         | 710        | 830    | 950            | 875                         | 1040       | 1210   | 1380           |
| Default Cool CFM              | 565                         | 670        | 760    | 860            | 800                         | 945        | 1100   | 1240           |
| Decrease(-10%) Cool CFM       | 520                         | 610        | 685    | 785            | 720                         | 840        | 970    | 1115           |

The effect of static pressure is included in air volumes shown.

The following control configurations are available. See Installation Instructions for details and DIP switch settings.

Heat Modes Available (Heating Blower Performance table):

Single stage thermostat:

- 35%, 70%, 100% input (three-stage) with time delays in-between

Two-stage thermostat:

- Variable Rate Capacity Mode - furnace automatically adjusts firing rate based on first- and second-stage cycle times

- W1 demand at 70% input, W2 demand at 100% input. No delay between stages

Cool Mode Available (Cooling Blower Performance table):

First stage COOL (two-stage air conditioning units only) is approximately 70% of the same second stage COOL speed position

Continuous Fan speeds are approximately 38% of the same second-stage COOL speed position minimum 300 cfm

**A98USMV090C16S BLOWER PERFORMANCE (less filter)**

**HEATING BLOWER PERFORMANCE**

| Heating Adjust CFM Selections | Heating Input Range and Blower Volume - CFM |     |     |      |      |      |      |      |
|-------------------------------|---|-----|-----|------|------|------|------|------|
|                               | 35%   | 40% | 50% | 60%  | 70%  | 80%  | 90%  | 100% |
| Increase (+15%) Heat CFM      | 769   | 835 | 968 | 1101 | 1234 | 1367 | 1500 | 1633 |
| Increase (+7.5%) Heat CFM     | 713   | 776 | 902 | 1028 | 1155 | 1281 | 1407 | 1534 |
| Default Heat CFM              | 656   | 716 | 836 | 955  | 1075 | 1195 | 1314 | 1434 |
| Decrease (-7.5% ) Heat CFM    | 595   | 652 | 767 | 882  | 997  | 1112 | 1227 | 1342 |
| Decrease (-15% ) Heat CFM     | 534   | 589 | 699 | 809  | 919  | 1029 | 1139 | 1249 |

**COOLING BLOWER PERFORMANCE**

| Cooling Adjust CFM Selections | Blower Speed Selections     |            |        |                |                             |            |        |                |
|-------------------------------|-----------------------------|------------|--------|----------------|-----------------------------|------------|--------|----------------|
|                               | First Stage Cool Speed- cfm |            |        |                | Second Stage Cool Speed-cfm |            |        |                |
|                               | Low                         | Medium Low | Medium | High (Default) | Low                         | Medium Low | Medium | High (Default) |
| Increase (+10%) Cool CFM      | 840                         | 1005       | 1155   | 1315           | 1165                        | 1375       | 1580   | 1770           |
| Default Cool CFM              | 780                         | 915        | 1045   | 1190           | 1075                        | 1265       | 1440   | 1645           |
| Decrease(-10%) Cool CFM       | 690                         | 835        | 955    | 1070           | 935                         | 1145       | 1320   | 1465           |

**A98USMV090C20S BLOWER PERFORMANCE (less filter)**

**HEATING BLOWER PERFORMANCE**

| Heating Adjust CFM Selections | Heating Input Range and Blower Volume - CFM |     |     |     |      |      |      |      |
|-------------------------------|---|-----|-----|-----|------|------|------|------|
|                               | 35%   | 40% | 50% | 60% | 70%  | 80%  | 90%  | 100% |
| Increase (+15%) Heat CFM      | 583   | 665 | 830 | 995 | 1159 | 1324 | 1488 | 1653 |
| Increase (+7.5%) Heat CFM     | 540   | 618 | 774 | 930 | 1085 | 1241 | 1397 | 1553 |
| Default Heat CFM              | 497   | 571 | 718 | 865 | 1012 | 1159 | 1306 | 1453 |
| Decrease (-7.5% ) Heat CFM    | 439   | 507 | 644 | 781 | 917  | 1054 | 1191 | 1328 |
| Decrease (-15% ) Heat CFM     | 380   | 443 | 570 | 697 | 823  | 950  | 1076 | 1203 |

**COOLING BLOWER PERFORMANCE**

| Cooling Adjust CFM Selections | Blower Speed Selections     |            |        |                |                             |            |        |                |
|-------------------------------|-----------------------------|------------|--------|----------------|-----------------------------|------------|--------|----------------|
|                               | First Stage Cool Speed- cfm |            |        |                | Second Stage Cool Speed-cfm |            |        |                |
|                               | Low                         | Medium Low | Medium | High (Default) | Low                         | Medium Low | Medium | High (Default) |
| Increase (+10%) Cool CFM      | 933                         | 1054       | 1274   | 1466           | 1385                        | 1593       | 1818   | 2019           |
| Default Cool CFM              | 836                         | 978        | 1121   | 1336           | 1226                        | 1463       | 1647   | 1884           |
| Decrease(-10%) Cool CFM       | 740                         | 868        | 1010   | 1152           | 1063                        | 1320       | 1504   | 1675           |

The effect of static pressure is included in air volumes shown.

The following control configurations are available. See Installation Instructions for details and DIP switch settings.

Heat Modes Available (Heating Blower Performance table):

Single stage thermostat:

- 35%, 70%, 100% input (three-stage) with time delays in-between

Two-stage thermostat:

- Variable Rate Capacity Mode - furnace automatically adjusts firing rate based on first- and second-stage cycle times

- W1 demand at 70% input, W2 demand at 100% input. No delay between stages

Cool Mode Available (Cooling Blower Performance table):

First stage COOL (two-stage air conditioning units only) is approximately 70% of the same second stage COOL speed position

Continuous Fan speeds are approximately 38% of the same second-stage COOL speed position minimum 300 cfm

**A98USMV110C20S BLOWER PERFORMANCE (less filter)**

**HEATING BLOWER PERFORMANCE**

| Heating Adjust CFM Selections | Heating Input Range and Blower Volume - CFM |     |      |      |      |      |      |      |
|-------------------------------|---|-----|------|------|------|------|------|------|
|                               | 35%   | 40% | 50%  | 60%  | 70%  | 80%  | 90%  | 100% |
| Increase (+15%) Heat CFM      | 767   | 861 | 1049 | 1237 | 1424 | 1612 | 1800 | 1988 |
| Increase (+7.5%) Heat CFM     | 738   | 825 | 1000 | 1174 | 1349 | 1524 | 1699 | 1874 |
| Default Heat CFM              | 708   | 789 | 951  | 1112 | 1274 | 1436 | 1597 | 1759 |
| Decrease (-7.5% ) Heat CFM    | 655   | 731 | 883  | 1035 | 1187 | 1339 | 1491 | 1644 |
| Decrease (-15% ) Heat CFM     | 602   | 673 | 816  | 958  | 1101 | 1243 | 1386 | 1528 |

**COOLING BLOWER PERFORMANCE**

| Cooling Adjust CFM Selections | Blower Speed Selections     |            |        |                |                             |            |        |                |
|-------------------------------|-----------------------------|------------|--------|----------------|-----------------------------|------------|--------|----------------|
|                               | First Stage Cool Speed- cfm |            |        |                | Second Stage Cool Speed-cfm |            |        |                |
|                               | Low                         | Medium Low | Medium | High (Default) | Low                         | Medium Low | Medium | High (Default) |
| Increase (+10%) Cool CFM      | 937                         | 1064       | 1247   | 1407           | 1312                        | 1560       | 1744   | 1955           |
| Default Cool CFM              | 864                         | 972        | 1146   | 1282           | 1219                        | 1405       | 1569   | 1796           |
| Decrease(-10%) Cool CFM       | 790                         | 888        | 1025   | 1167           | 1075                        | 1272       | 1428   | 1634           |

**A98USMV135D20S BLOWER PERFORMANCE (less filter)**

**HEATING BLOWER PERFORMANCE**

| Heating Adjust CFM Selections | Heating Input Range and Blower Volume - CFM |      |      |      |      |      |      |      |
|-------------------------------|---|------|------|------|------|------|------|------|
|                               | 35%   | 40%  | 50%  | 60%  | 70%  | 80%  | 90%  | 100% |
| Increase (+15%) Heat CFM      | 949   | 1033 | 1200 | 1367 | 1534 | 1701 | 1868 | 2035 |
| Increase (+7.5%) Heat CFM     | 879   | 957  | 1113 | 1269 | 1426 | 1582 | 1738 | 1895 |
| Default Heat CFM              | 808   | 881  | 1026 | 1172 | 1317 | 1463 | 1608 | 1754 |
| Decrease (-7.5% ) Heat CFM    | 748   | 817  | 956  | 1095 | 1235 | 1374 | 1513 | 1652 |
| Decrease (-15% ) Heat CFM     | 687   | 753  | 886  | 1019 | 1152 | 1284 | 1417 | 1550 |

**COOLING BLOWER PERFORMANCE**

| Cooling Adjust CFM Selections | Blower Speed Selections     |            |        |                |                             |            |        |                |
|-------------------------------|-----------------------------|------------|--------|----------------|-----------------------------|------------|--------|----------------|
|                               | First Stage Cool Speed- cfm |            |        |                | Second Stage Cool Speed-cfm |            |        |                |
|                               | Low                         | Medium Low | Medium | High (Default) | Low                         | Medium Low | Medium | High (Default) |
| Increase (+10%) Cool CFM      | 935                         | 1074       | 1260   | 1450           | 1353                        | 1567       | 1751   | 1994           |
| Default Cool CFM              | 834                         | 983        | 1116   | 1306           | 1202                        | 1448       | 1616   | 1828           |
| Decrease(-10%) Cool CFM       | 732                         | 867        | 1023   | 1145           | 1080                        | 1290       | 1472   | 1668           |

The effect of static pressure is included in air volumes shown.

The following control configurations are available. See Installation Instructions for details and DIP switch settings.

Heat Modes Available (Heating Blower Performance table):

Single stage thermostat:

- 35%, 70%, 100% input (three-stage) with time delays in-between

Two-stage thermostat:

- Variable Rate Capacity Mode - furnace automatically adjusts firing rate based on first- and second-stage cycle times

- W1 demand at 70% input, W2 demand at 100% input. No delay between stages

Cool Mode Available (Cooling Blower Performance table):

First stage COOL (two-stage air conditioning units only) is approximately 70% of the same second stage COOL speed position

Continuous Fan speeds are approximately 38% of the same second-stage COOL speed position minimum 300 cfm

| Model      | -15%    | -7.5%   | Default         | +7.5%   | +15%    |
|------------|---------|---------|-----------------|---------|---------|
| All Models | Allowed | Allowed | Factory Setting | Allowed | Allowed |

**Table 19. Allowable Heating Speeds**

| Model      | 38% of Second Stage Cooling |
|------------|-----------------------------|
| All Models | Allowed                     |

**Table 20. Allowable Circulation Speeds**

| Operating Sequence   |      | System Demand  |    |    |                   |        | System Response |                   |   |
|--|------|--|----|----|-------------------|--------|-----------------|-------------------|---|
| System Condition   | Step | Thermostat Demand  |    |    | Relative Humidity |        | Compressor      | Blower CFM (COOL) | Comments  |
|  |      | 1st Stage  | O  | G  | Status            | D      |                 |                   |   |
| <b>NO CALL FOR DEHUMIDIFICATION</b>                                    |      |  |    |    |                   |        |                 |                   |   |
| Normal Operation   | 1    | On   | On | On | Acceptable        | 24 VAC | High            | 100%              | Compressor and indoor blower follow thermostat demand   |
| <b>BASIC MODE (only active on a Y1 thermostat demand)</b>              |      |  |    |    |                   |        |                 |                   |   |
| Normal Operation   | 1    | On   | On | On | Acceptable        | 24 VAC | High            | 100%              | Thermostat energizes Y1 and de-energizes D on a call for de-humidification  |
| Dehumidification Call  | 2    | On   | On | On | Demand            | 0 VAC  | High            | 70%               |   |
| <b>PRECISION MODE (operates independent of a Y1 thermostat demand)</b> |      |  |    |    |                   |        |                 |                   |   |
| Normal Operation   | 1    | On   | On | On | Acceptable        | 24 VAC | High            | 100%              | Dehumidification mode begins when humidity is greater than set point. Maximum overcool from cooling setpoint is 2°F.  |
| Dehumidification Call  | 2    | On   | On | On | Demand            | 0 VAC  | High            | 70%               |   |
| Dehumidification Call ONLY   | 1    | On   | On | On | Demand            | 0 VAC  | High            | 70%               | Thermostat will keep outdoor unit energized after cooling temperature setpoint has been reached in order to maintain room humidity setpoint. Maximum overcool from cooling setpoint is 2°F. |
|  |      | <ul style="list-style-type: none"> <li>• On-board links at indoor unit with a single stage outdoor unit</li> <li>• With Condensing unit - Cut W914 (R to OS) on integrated control</li> <li>• With Heat Pump - Cut W914 (R to DS) and W951 (R to O) on integrated control</li> </ul> |    |    |                   |        |                 |                   |   |

**Table 21. Cooling Operating Sequence  
A98USMV and Single Stage Outdoor Unit**



| Operating Sequence   |      | System Demand  |           |    |    |                   |        | System Response |                   |   |
|--|------|--|-----------|----|----|-------------------|--------|-----------------|-------------------|---|
| System Condition   | Step | Thermostat Demand  |           |    |    | Relative Humidity |        | Compressor      | Blower CFM (COOL) | Comments  |
|  |      | 1st Stage  | 2nd Stage | O  | G  | Status            | D      |                 |                   |   |
| <b>NO CALL FOR DEHUMIDIFICATION</b>                                    |      |  |           |    |    |                   |        |                 |                   |   |
| Normal Operation - Y1  | 1    | On   |           | On | On | Acceptable        | 24 VAC | Low             | 70%               | Compressor and indoor blower follow thermostat demand   |
| Normal Operation - Y2  | 2    | On   | On        | On | On | Acceptable        | 24 VAC | High            | 100%              |   |
| <b>ROOM THERMOSTAT CALLS FOR FIRST STAGE COOLING</b>                   |      |  |           |    |    |                   |        |                 |                   |   |
| <b>BASIC MODE (only active on a Y1 thermostat demand)</b>              |      |  |           |    |    |                   |        |                 |                   |   |
| Normal Operation   | 1    | On   |           | On | On | Acceptable        | 24 VAC | Low             | 70%               | Thermostat energizes 2nd Stage and de-energizes D on a call for de-humidification   |
| Dehumidification Call  | 2    | On   | On        | On | On | Demand            | 0 VAC  | High            | 70%               |   |
| <b>PRECISION MODE (operates independent of a Y1 thermostat demand)</b> |      |  |           |    |    |                   |        |                 |                   |   |
| Normal Operation   | 1    | On   |           | On | On | Acceptable        | 24 VAC | Low             | 70%               | Dehumidification mode begins when humidity is greater than set point. Maximum overcool from cooling setpoint is 2°F.  |
| Dehumidification Call  | 2    | On   | On        | On | On | Demand            | 0 VAC  | High            | 70%               |   |
| Dehumidification Call ONLY   | 1    | On   | On        | On | On | Demand            | 0 VAC  | High            | 70%               | Thermostat will keep outdoor unit energized after cooling temperature setpoint has been reached in order to maintain room humidity setpoint. Maximum overcool from cooling setpoint is 2°F. |
| <b>ROOM THERMOSTAT CALLS FOR FIRST AND SECOND STAGE COOLING</b>        |      |  |           |    |    |                   |        |                 |                   |   |
| <b>BASIC MODE (only active on a Y1 thermostat demand)</b>              |      |  |           |    |    |                   |        |                 |                   |   |
| Normal Operation   | 1    | On   | On        | On | On | Acceptable        | 24 VAC | High            | 100%              | Thermostat energizes 2nd Stage and de-energizes D on a call for de-humidification   |
| Dehumidification Call  | 2    | On   | On        | On | On | Demand            | 0 VAC  | High            | 70%               |   |
| <b>PRECISION MODE (operates independent of a Y1 thermostat demand)</b> |      |  |           |    |    |                   |        |                 |                   |   |
| Normal Operation   | 1    | On   |           | On | On | Acceptable        | 24 VAC | Low             | 70%               | Dehumidification mode begins when humidity is greater than set point. Maximum overcool from cooling setpoint is 2°F.  |
| Dehumidification Call  | 2    | On   | On        | On | On | Demand            | 0 VAC  | High            | 70%               |   |
| Dehumidification Call ONLY   | 1    | On   | On        | On | On | Demand            | 0 VAC  | High            | 70%               | Thermostat will keep outdoor unit energized after cooling temperature setpoint has been reached in order to maintain room humidity setpoint. Maximum overcool from cooling setpoint is 2°F. |
|  |      | <ul style="list-style-type: none"> <li>On-board links at indoor unit with a two stage outdoor unit</li> <li>Cut factory link from Y1 to Y2 or cut W915 (Y1 to Y2) on integrated control</li> <li>With Condensing unit - Cut W914 (R to OS) on integrated control</li> <li>With Heat Pump - Cut W914 (R to DS) and W951 (R to O) on integrated control</li> </ul> |           |    |    |                   |        |                 |                   |   |

**Table 22. Cooling Operating Sequence  
A98USMV and Two Stage Outdoor Unit**

## Unit Start-Up

### FOR YOUR SAFETY READ BEFORE OPERATING

#### WARNING

Do not use this furnace if any part has been underwater. A flood damaged furnace is extremely dangerous. Attempts to use the furnace can result in fire or explosion. Immediately call a qualified service technician to inspect the furnace and to replace all gas controls, control system parts, and electrical parts that have been wet or to replace the furnace, if deemed necessary.

#### WARNING

##### Danger of explosion.



Can cause injury or product or property damage. Should the gas supply fail to shut off or if overheating occurs, shut off the gas valve to the furnace before shutting off the electrical supply.

#### CAUTION

Before attempting to perform any service or maintenance, turn the electrical power to unit OFF at disconnect switch.

#### WARNING

During blower operation, the ECM motor emits energy that may interfere with pacemaker operation. Interference is reduced by both the sheet metal cabinet and distance.

### Priming Condensate Trap

The condensate trap should be primed with water prior to startup to ensure proper condensate drainage. Either pour 10 fl. oz. (300 ml) of water into the trap, or follow these steps to prime the trap:

1. Follow the lighting instructions to place the unit into operation.
2. Set the thermostat to initiate a heating demand.
3. Allow the burners to fire for approximately 3 minutes.
4. Adjust the thermostat to deactivate the heating demand.

5. Wait for the combustion air inducer to stop. Set the thermostat to initiate a heating demand and again allow the burners to fire for approximately 3 minutes.
6. Adjust the thermostat to deactivate the heating demand and again wait for the combustion air inducer to stop. At this point, the trap should be primed with sufficient water to ensure proper condensate drain operation.

### BEFORE PLACING THE UNIT INTO OPERATION

Smell all around the furnace area for gas. Be sure to smell next to the floor because some gas is heavier than air and will settle on the floor.

The gas valve on these units is equipped with a gas control switch. Use only your hand to move the control switch. Never use tools. If the switch will not move by hand, do not try to repair it. Force or attempted repair may result in a fire or explosion.

### Placing the Furnace into Operation

These units are equipped with an automatic ignition system. Do not attempt to manually light burners on this furnace. Each time the thermostat calls for heat, the burners will automatically light. The ignitor does not get hot when there is no call for heat on units with this ignition system.

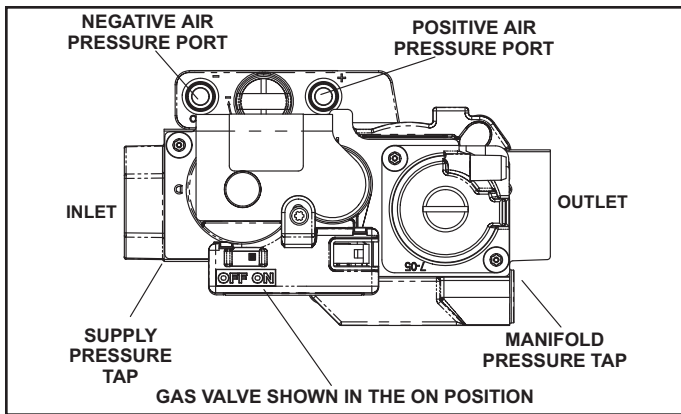
#### WARNING

If you do not follow these instructions exactly, a fire or explosion may result causing property damage, personal injury or death.

### Gas Valve Operation

See Figure 57

1. STOP! Read the safety information at the beginning of this section.
2. Set the thermostat to the lowest setting.
3. Turn OFF all electrical power to the unit.
4. This furnace is equipped with an ignition device that automatically lights the burners. DO NOT try to light the burners by hand.
5. Remove the access panel.
6. Move the gas valve switch to the OFF position. See Figure 57.
7. Wait five minutes to clear out any gas. If you then smell gas, STOP! Immediately call the gas supplier from a neighbor's phone. Follow the gas supplier's instructions. If you do not smell gas, go to the next step.
8. Move gas valve switch to the ON position. See Figure 57. DO NOT force.



**Figure 57. Gas Valve**

9. Replace the access panel.
10. Turn on all electrical power to the unit.
11. Set the thermostat to desired setting.  
**NOTE:** When unit is initially started, steps 1 through 11 may need to be repeated to purge air from gas line.
12. If the Appliance will not operate, follow the instructions "Turning Off Gas to Unit" and call the gas supplier.

**Turning Off Gas to Unit**

1. Set the thermostat to the lowest setting.
2. Turn OFF all electrical power to the unit if service is to be performed.
3. Remove the access panel.
4. Move the gas valve switch to the OFF position.
5. Replace the access panel.

**Failure to Operate**

If the unit fails to operate, check the following:

1. Is the thermostat calling for heat?
2. Are access panels securely in place?
3. Is the main disconnect switch closed?
4. Is there a blown fuse?
5. Is the filter dirty or plugged? Dirty or plugged filters will cause the limit control to shut the unit off.
6. Is gas turned on at the meter?
7. Is the manual main shut Off valve open?
8. Is the gas valve turned on?
9. Is the unit ignition system in lock out: If the unit locks out again, inspect the unit for blockages.
10. Is blower harness connected to ignition control? Furnace will not operate unless harness is connected.

**Gas Pressure Measurement**

**Gas Flow (Approximate)**

| Capacity | Seconds for One Revolution |              |                     |              |
|----------|----------------------------|--------------|---------------------|--------------|
|          | Natural                    |              | LP                  |              |
|          | 1 cu ft Dial               | 2 cu ft Dial | 1 cu ft Dial        | 2 cu ft Dial |
| -070     | 55                         | 110          | 136                 | 272          |
| -090     | 41                         | 82           | 102                 | 204          |
| -110     | 33                         | 66           | 82                  | 164          |
| -135     | 27                         | 54           | 68                  | 136          |
|          | Natural - 1000 btu/cu ft   |              | LP - 2500 btu/cu ft |              |

**Table 23. Gas Meter Clocking Chart**

Furnace should operate at least 5 minutes before checking gas flow. Determine time in seconds for two revolutions of gas through the meter. (Two revolutions assures a more accurate time.) Divide by two and compare to time in Table 23. If manifold pressure matches Table 26 and rate is incorrect, check gas orifices for proper size and restriction. Remove temporary gas meter if installed.

**NOTE:** A natural to LP/propane gas changeover kit is necessary to convert this unit. Refer to the changeover kit installation instructions for the conversion procedure.

**NOTE:** To obtain accurate reading, shut off all other gas appliances connected to meter.

**Supply Pressure Measurement**

A threaded plug on the inlet side of the gas valve provides access to the supply pressure tap. Remove the threaded plug, install a field provided barbed fitting and connect a manometer to measure supply pressure. Replace the threaded plug after measurements have been taken.

**Manifold Pressure Measurement**

To correctly measure manifold pressure, the differential pressure between the positive gas manifold and the negative burner box must be considered. Use pressure test adapter kit (available as part 10L34) to assist in measurement.

1. Remove the threaded plug from the outlet side of the gas valve and install a field provided barbed fitting. Connect test gauge "+" connection to barbed fitting to measure manifold pressure.
2. Tee into the gas valve regulator vent hose and connect test gauge "-" connection.
3. Start unit on low heat (35% rate) and allow 5 minutes for unit to reach steady state.
4. While waiting for the unit to stabilize, notice the flame. Flame should be stable and should not lift from burner. Natural gas should burn blue.

- After allowing unit to stabilize for 5 minutes, record manifold pressure and compare to value given in Table 26.
- Repeat steps 3, 4 and 5 on HIGH HEAT.

**NOTE:** Shut unit off and remove manometer as soon as an accurate reading has been obtained. Take care to remove barbed fitting and replace threaded plug.

 **CAUTION**

**DO NOT** attempt to make adjustments to the gas valve.

### Operating Pressure Signal

Operating pressure signal can be taken while the manifold pressure check is taken (using two measuring devices). Or, taken after the manifold pressure measurement is complete.

- Tee into the negative line between the gas valve and pressure switch and connect to measuring device negative “-”.
- Tee into the positive line between the gas valve and pressure switch and connect to measuring device positive “+”.
- Start unit on low heat (35% rate) and allow 5 minutes for unit to reach steady state.
- After allowing unit to stabilize for 5 minutes, record operating pressure signal and compare to value given in Table 26.
- Repeat steps 3 - 4 on high heat.

### High Altitude Information

**NOTE:** In Canada, certification for installation at elevations over 4500 feet (1372 m) is the jurisdiction of local authorities.

These units require no manifold pressure adjustments for operation at altitudes up to 10,000 feet (2286 m) above sea level. Table 27 lists conversion kit requirements, pressure switch requirements and manifold pressures at all altitudes. The combustion air pressure switch is factory set and requires no adjustment.

### Proper Combustion

Furnace should operate a minimum of 15 minutes with correct manifold pressure and gas flow rate before checking combustion. Take combustion sample beyond the flue outlet and compare to Table 24 and Table 25. The maximum carbon monoxide reading should not exceed 100 ppm.

| Model | CO <sub>2</sub> % for Nat | CO <sub>2</sub> % for LP |
|-------|---------------------------|--------------------------|
| All   | 7.6 - 8.6                 | 9.1 - 10.1               |

**Table 24. Proper Combustion - High Fire**

| Model | CO <sub>2</sub> % for Nat | CO <sub>2</sub> % for LP |
|-------|---------------------------|--------------------------|
| 070   | 5.7                       | 7.2 - 8.2                |
| 090   | 5.3 - 6.3                 | 6.8 - 7.8                |
| 110   |                           |                          |
| 135   |                           |                          |

**Table 25. Proper Combustion - Low Fire**

| Firing Rate | Manifold Pressure Nat Gas |        |     | Manifold Pressure LP/Propane |        |      | Operating Pressure Signal (Delta P) |        |      |
|-------------|---------------------------|--------|-----|------------------------------|--------|------|-------------------------------------|--------|------|
|             | Min                       | Normal | Max | Min                          | Normal | Max  | Min                                 | Normal | Max  |
| 35%         | 0.4                       | 0.6    | 0.7 | 1.2                          | 1.6    | 1.9  | 0.25                                | 0.30   | 0.35 |
| 70%         | 1.7                       | 1.9    | 2.1 | 5.1                          | 5.5    | 5.9  | 0.60                                | 0.65   | 0.70 |
| 100%        | 3.2                       | 3.5    | 3.8 | 9.5                          | 10.0   | 10.5 | 1.10                                | 1.15   | 1.20 |

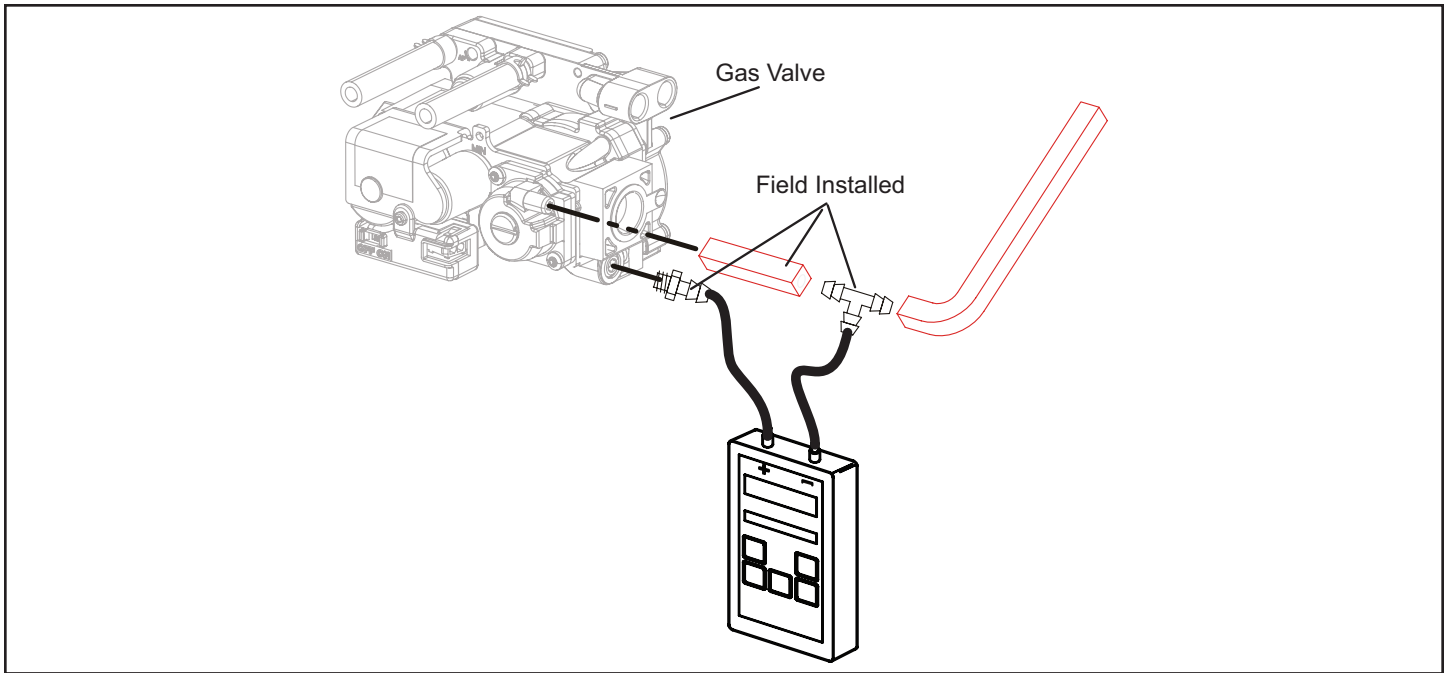
NOTE: A natural to LP/propane gas changeover kit (Table 27) is necessary to convert this unit. Refer to the changeover kit installation instructions for the conversion procedure.

**Table 26. Manifold and Operating Signal Pressures in inches 0-7500 ft (0-2286 m)**

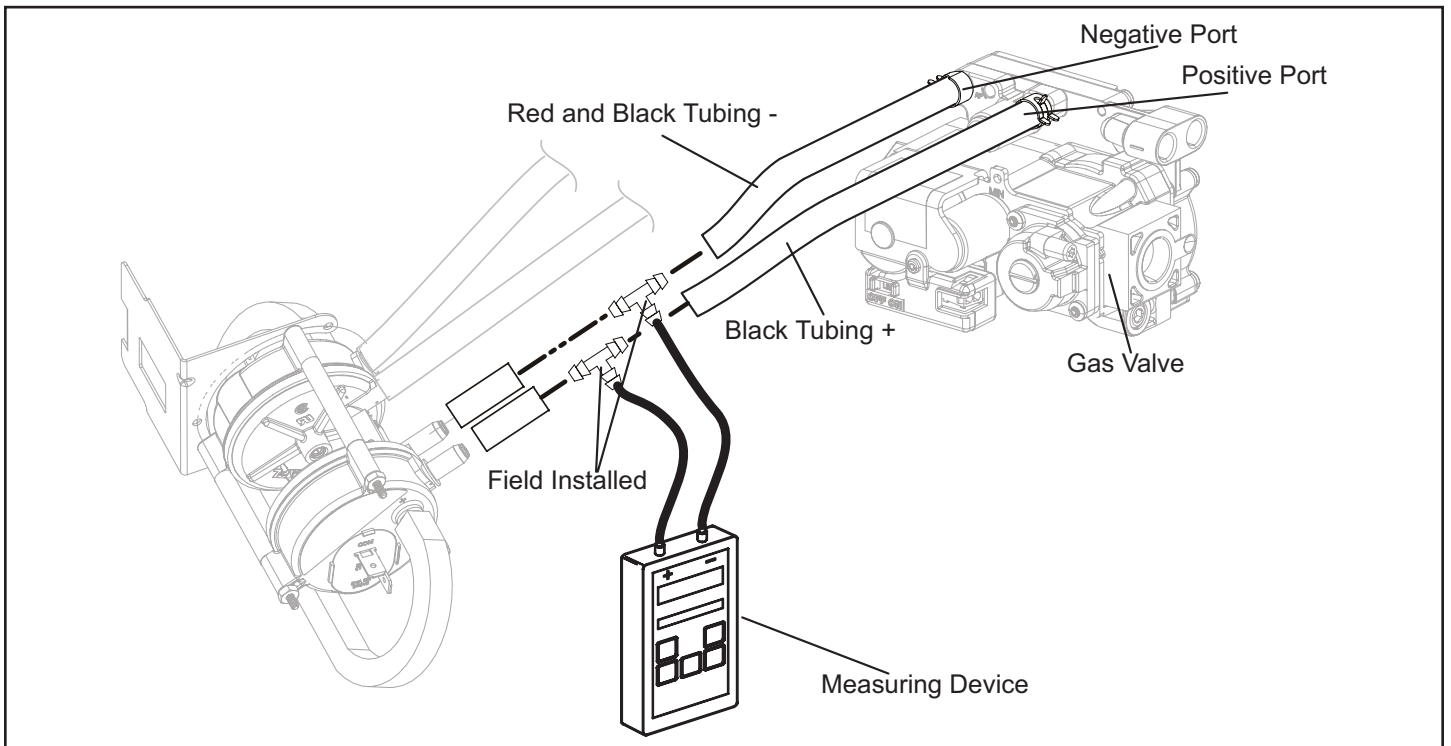
| Model | LP/Propane Kit                 | High Altitude Pressure Switch Kit |  | Manifold Pressure at All Altitudes (in. w.g.) |              |                          |              | Gas Orifice Size |              |
|-------|--------------------------------|-----------------------------------|--|---|--------------|--------------------------|--------------|------------------|--------------|
|       | 1 - 10,000 ft<br>(0 - 3,048 m) | 0 - 7,500 ft<br>(0 - 2,286 m)     | 7,501 - 10,000 ft<br>(2,287 - 3,048 m) | Low Fire<br>(35% rate)                        |              | High Fire<br>(100% rate) |              |                  |              |
|       |                                |                                   |  | Natural Gas                                   | LP / Propane | Natural Gas              | LP / Propane | Natural Gas      | LP / Propane |
| All   | 68W77                          | Not required                      | 14T65                                  | 0.40 - 0.60                                   | 1.2 - 1.8    | 3.2 - 3.8                | 9.5 - 10.5   | 0.0625           | 0.034        |

NOTE: The values given are measurements only. The gas valve should not be adjusted.

**Table 27. Conversion Kit Requirements and Manifold Test Pressures**



**Figure 58. Manifold Pressure Measurement**



**Figure 59. Operation Signal (Delta P) Measurement**

## Other Unit Adjustments

### Primary Limit

The primary limit is located on the heating compartment vestibule panel. This limit is factory set and requires no adjustment.

### Flame Rollout Switches (Two)

These manually reset switches are located on the inside of the burner box. If tripped, check for adequate combustion air before resetting.

### Pressure Switches (Two)

The pressure switches are located on the cold end header box. These switches check for proper combustion air inducer operation before allowing ignition trial. The switches are factory set and require no adjustment. Pressure switch tubing installation is critical for safe operation. See Figure 60.

### Temperature Rise

After the furnace has been started and supply and return air temperatures have been allowed to stabilize, check the temperature rise with the unit operating at 100 percent firing rate. If necessary, adjust the blower speed to maintain the temperature rise within the range shown on the unit nameplate. See Table 19 for allowable heating speeds. Increase the blower speed to decrease the temperature. Decrease the blower speed to increase the temperature rise. Failure to adjust the temperature rise may cause erratic limit operation.

### Thermostat Heat Anticipation

Set the heat anticipator setting (if adjustable) according to the amp draw listed on the wiring diagram that is attached to the unit.

### Electronic Ignition

The integrated control has a feature that serves as an automatic reset device for ignition control lockout caused by ignition failure. This type of lockout is usually due to low gas line pressure. After one hour of continuous thermostat demand for heat, the control will break and remake thermostat demand to the furnace and automatically reset the control to begin the ignition sequence.

### Exhaust and Air Intake Pipe

1. Check exhaust and air intake connections for tightness and to make sure there is not blockage.
2. Are pressure switches closed? Obstructed exhaust pipe will cause unit to shut off at pressure switches. Check termination for blockages.
3. Reset manual flame rollout switches on burner box cover.

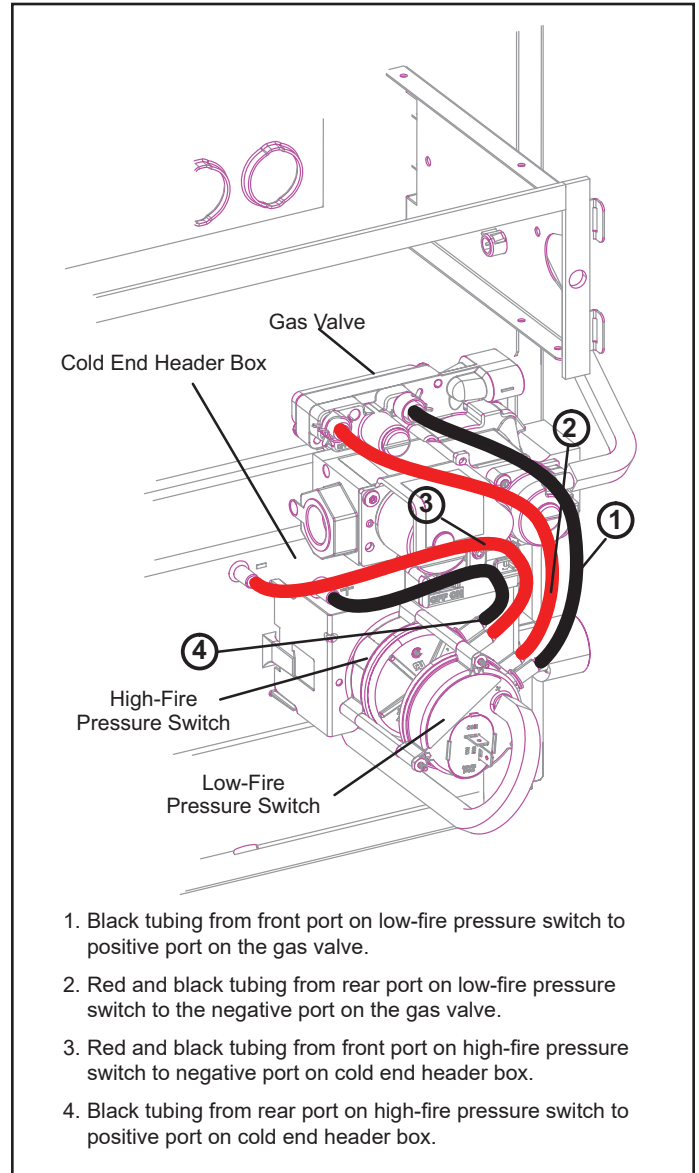


Figure 60. Pressure Switch Tubing Installation

## Heating Sequence of Operation

The integrated control initiates a pressure switch calibration at the initial unit start-up on a call for heat. The ignition control will also initiate a calibration any time main power is turned off and back on and a heating demand is present. Additional calibrations may be initiated by the service technician during field test sequence. The following heating sequence of operation assumes completion of a successful calibration.

**NOTE:** *In Comfort Sync communicating applications, the sequence of operation is the same but all DIP switch settings are overridden by the thermostat.*

**NOTE:** *The thermostat selection DIP switch on the integrated control is factory set in the "TWO STAGE" position.*

### Applications Using a Two Stage Thermostat

#### **A-Heating Sequence - Control Thermostat Selection DIP Switch in "Two Stage" Position (Factory Settling)**

1. On a call for heat, thermostat first stage contacts close, sending a signal to the integrated control. The integrated control runs a self diagnostic program and checks high temperature limit switches for normally closed contacts and pressure switches for normally open contacts. The combustion air inducer is energized at ignition speed, which is approximately the same as the inducer speed at 70 percent firing rate.
2. Once the control receives a signal that the low fire pressure switch has closed, the combustion air inducer begins a 15 second pre-purge in the ignition speed.
3. After the pre-purge is complete, a 20 second initial ignitor warm up period begins. The combustion air inducer continues to operate at the ignition speed.
4. After the 20 second warm up period has ended, the gas valve is energized and ignition occurs. At the same time, the control module sends a signal to begin an indoor blower 30 second ON delay. When the delay ends, the indoor blower motor is energized at a speed that matches the firing rate. After the 10 second ignition stabilization delay expires, the inducer speed is adjusted to the appropriate target rate. The inducer will remain at the 70 percent speed as long as the thermostat has a first stage heating demand.
5. If second stage heat is required, the thermostat second stage heat contacts close and send a signal to the integrated control. The integrated control initiates a 30 second second stage recognition delay.
6. At the end of the recognition delay and on all subsequent calls for heat in the same heating cycle, the integrated control energizes the combustion air inducer at high speed. The control also checks the high fire pressure switch to make sure it is closed. As the inducer speed is increased to high, the indoor blower motor is adjusted to a speed appropriate for the

target rate.

7. When the demand for high fire (second stage) heat is satisfied, the gas valve is de-energized and the field selected indoor blower off delay begins. The combustion air inducer begins a 20 second post purge period.
8. When the combustion air post purge period is complete, the inducer is de-energized. The indoor blower is deenergized at the end of the off delay.

#### **B - Heating Sequence - Control Thermostat Selection DIP Switch in "Variable Capacity" Position**

1. On a call for heat, thermostat first stage contacts close, sending a signal to the integrated control. The integrated control runs a self diagnostic program and checks high temperature limit switches for normally closed contacts and pressure switches for normally open contacts. The combustion air inducer is energized at ignition speed, which is approximately the same as the inducer speed at 70 percent firing rate.
2. Once the control receives a signal that the low fire pressure switch has closed, the combustion air inducer begins a 15 second pre-purge in low speed.
3. After the pre-purge is complete, a 20 second initial ignitor warm up period begins. The combustion air inducer continues to operate at the ignition speed.
4. After the 20 second warm up period has ended, the gas valve is energized and ignition occurs. At the same time, the control module begins an indoor blower 30 second ON delay. When the delay ends, the indoor blower motor is energized at a speed that matches the firing rate. After the 10 second ignition stabilization delay expires, the inducer speed is adjusted to the appropriate target rate. If the furnace is operating in the initial heating cycle after power up, the initial firing rate will be approximately 35 percent. The firing rate on subsequent cycles will be automatically adjusted by the integrated control based on thermostat cycles. The firing rate will vary and will range from 35 percent to 90 percent. The furnace will continue this operation as long as the thermostat has a first stage heating demand.
5. If second stage heat is required, the thermostat second stage heat contacts close and send a signal to the integrated control. The integrated control either increases the firing rate to 70 percent (if the current rate is at or below 60 percent) or increases the firing rate by 10 percent (if the current rate is above 60 percent). If the call for heat continues 5 minutes beyond this initial upstage, the rate will be increased by 10 percent every 5 minutes until the call for heat is satisfied or the furnace reaches 100 percent rate. As the firing rate increases, the indoor blower motor is adjusted to a speed appropriate for the target rate.
6. If second-stage heat demand is satisfied, but first stage is still present, the furnace will continue to operate at

the present firing rate until the heat cycle ends.

7. When the demand for first and second stage heat is satisfied, the gas valve is de-energized and the field selected indoor blower OFF delay begins. The combustion air inducer begins a 20 second post-purge period.
8. When the combustion air post-purge period is complete, the inducer is de-energized. The indoor blower is de-energized at the end of the OFF delay.

### **Applications Using A Single-Stage Thermostat C - Heating Sequence -- Control Thermostat Selection DIP Switch in "Single Stage" Position**

1. On a call for heat, thermostat first stage contacts close, sending a signal to the integrated control. The integrated control runs a self-diagnostic program and checks high temperature limit switches for normally closed contacts and pressure switches for normally open contacts. The combustion air inducer is energized at the ignition speed, which is approximately the same as the inducer speed at 70 percent firing rate.
2. Once the control receives a signal that the low fire pressure switch has closed, the combustion air inducer begins a 15 second pre-purge at the ignition speed.
3. After the pre-purge is complete, a 20 second initial ignitor warm up period begins. The combustion air inducer continues to operate at the ignition speed.
4. After the 20 second warm up period has ended, the gas valve is energized and ignition occurs, which initiates a 10 second ignition stabilization delay. At the same time, the control module sends a signal to begin an indoor blower 30 second ON delay. When the delay ends, the indoor blower motor is energized at a speed appropriate for the firing rate. After the 10 second ignition stabilization delay expires, the inducer speed is adjusted to 35 percent speed. The integrated control also initiates a second-stage ON delay (factory set at 7 minutes; adjustable to 12 minutes).
5. If the heating demand continues beyond the second stage ON delay, the integrated control energizes the combustion air inducer at 70 percent speed. The indoor blower motor is adjusted to a speed that matches the target rate. A fixed, 10 minute third stage on delay is initiated.
6. If the heating demand continues beyond the third stage ON delay, the integrated control energizes the inducer at high speed. The indoor blower motor is adjusted to a speed appropriate for the target rate.
7. When the thermostat heating demand is satisfied, the gas valve is de-energized and the combustion air inducer begins a 20 second post-purge. The field selected indoor blower OFF delay begins.
8. When the combustion air post-purge period is complete, the inducer is de-energized. The indoor blower is de-energized at the end of the OFF delay.

## **Service**

### **WARNING**

#### **ELECTRICAL SHOCK, FIRE, OR EXPLOSION HAZARD**

Failure to follow safety warnings exactly could result in dangerous operation, serious injury, death or property damage.

Improper servicing could result in dangerous operation, serious injury, death, or property damage.

Before servicing, disconnect all electrical power to furnace.

When servicing controls, label all wires prior to disconnecting. Take care to reconnect wires correctly. Verify proper operation after servicing.

At the beginning of each heating season, system should be checked as follows by a qualified service technician:

### **Blower**

Check the blower wheel for debris and clean if necessary. The blower motors are pre-lubricated for extended bearing life. No further lubrication is needed.

### **WARNING**

The blower access panel must be securely in place when the blower and burners are operating. Gas fumes, which could contain carbon monoxide, can be drawn into living space resulting in personal injury or death.

### **Filters**

All filters are installed external to the unit. Filters should be inspected monthly. Clean or replace the filters when necessary to ensure proper furnace operation. Table 1 lists recommended filter sizes.

### **Exhaust and Air Intake Pipes**

Check the exhaust and air intake pipes and all connections for tightness and to make sure there is no blockage.

**NOTE:** *After any heavy snow, ice or frozen fog event, the furnace vent pipes may become restricted. Always check the vent system and remove any snow or ice that may be obstructing the plastic intake or exhaust pipes.*

### **Electrical**

1. Check all wiring for loose connections.
2. Check for the correct voltage at the furnace (furnace operating).
3. Check amp-draw on the blower motor.

Motor Nameplate \_\_\_\_\_ Actual \_\_\_\_\_



## Winterizing and Condensate Trap Care

1. Turn off power to the unit.
2. Have a shallow pan ready to empty condensate water.
3. Remove the drain cap from the condensate trap and empty water. Inspect the trap then reinstall the drain cap.

## Cleaning Heat Exchanger

If cleaning the heat exchanger becomes necessary, follow the below procedures and refer to Figure 1 when disassembling unit. Use papers or protective covering in front of furnace while removing heat exchanger assembly.

1. Turn off electrical and gas supplies to the furnace.
2. Remove the furnace access panels.
3. Disconnect the 2 pin plug from the gas valve.
4. Remove gas supply line connected to gas valve. Remove the burner box cover and remove gas valve manifold assembly.
5. Remove sensor wire from sensor. Disconnect 2 pin plug from the ignitor.
6. Disconnect wires from flame rollout switches.
7. Remove four burner box screws at the vestibule panel and remove burner box. Set burner box assembly aside.

**NOTE:** *If necessary, clean burners at this time. Follow procedures outlined in Burner Cleaning section.*

8. Loosen the clamps to the flexible exhaust coupling.
9. Disconnect condensate drain line from the cold end header box.
10. Disconnect condensate drain tubing from flue collar. Remove screws that secure the flue collar into place. Remove flue collar. It may be necessary to cut the exiting exhaust pipe for removal of the fitting.
11. Mark and disconnect all combustion air pressure tubing from cold end header collector box.
12. Mark and remove wires from pressure switches. Remove pressure switches. Keep tubing attached to pressure switches.
13. Disconnect the 4 pin plug from the combustion air inducer. Remove the two screws that secure the combustion air inducer to the collector box. Remove combustion air inducer assembly. Remove ground wire from vest panel.
14. Remove electrical junction box from the side of the furnace.
15. Mark and disconnect any remaining wiring to heating compartment components. Disengage strain relief bushing and pull wiring and bushing through the hole in the blower deck.
16. Remove the primary limit from the vestibule panel.

17. Remove two screws from the front cabinet flange at the blower deck. Spread cabinet sides slightly to allow clearance for removal of heat exchanger.
18. Remove the screws along vestibule sides and bottom that secure the vestibule panel and heat exchanger assembly to cabinet. Remove the two screws from the blower rail that secure the bottom heat exchanger flange. Remove heat exchanger from furnace cabinet.
19. Back wash heat exchanger with soapy water solution or steam. If steam is used, it must be below 275°F (135°C).
20. Thoroughly rinse and drain the heat exchanger. Soap solutions can be corrosive. Take care to rinse entire assembly.
21. Reinstall heat exchanger into cabinet making sure that the clamshells of the heat exchanger assembly are resting on the support located at the rear of the cabinet. Remove the indoor blower to view this area through the blower opening.
22. Re-secure the supporting screws along the vestibule sides and bottom to the cabinet.
23. Reinstall cabinet screws on front flange at blower deck.
24. Reinstall the primary limit on the vestibule panel.
25. Route heating component wiring through hole in blower deck and reinsert strain relief bushing.
26. Reinstall electrical junction box.
27. Reinstall the combustion air inducer. Reconnect the 4 pin plug to the wire harness.
28. Reinstall pressure switches and reconnect pressure switch wiring.
29. Carefully connect combustion air pressure switch hosing from pressure switches to proper stubs on cold end header collector box.
30. Reconnect condensate drain line to the cold end header box.
31. Use securing screws to reinstall flue collar to the top cap on the furnace. Reconnect exhaust piping and exhaust drain tubing.
32. Replace flexible exhaust adapter on combustion air inducer and flue collar. Secure using two existing hose clamps.
33. Reinstall burner box assembly in vestibule area.
34. Reconnect flame roll-out switch wires.
35. Reconnect sensor wire and reconnect 2 pin plug from ignitor.
36. Secure burner box assembly to vestibule panel using four existing screws. Make sure burners line up in center of burner ports.
37. Reinstall gas valve manifold assembly. Reconnect gas supply line to gas valve.

38. Reinstall burner box cover.
39. Reconnect 2 pin plug to gas valve.
40. Replace the blower compartment access panel.
41. Refer to instruction on verifying gas and electrical connections when re-establishing supplies.
42. Follow lighting instructions to light and operate furnace for 5 minutes to ensure that heat exchanger is clean and dry and that furnace is operating properly.
43. Replace heating compartment access panel.

### **Cleaning the Burner Assembly**

1. Turn off electrical and gas power supplies to furnace. Remove upper and lower furnace access panels.
2. Disconnect the 2 pin plug from the gas valve.
3. Remove the burner box cover.
4. Disconnect the gas supply line from the gas valve. Remove gas valve/manifold assembly.
5. Mark and disconnect sensor wire from the sensor. Disconnect wires from flame rollout switches.
6. Remove the four screws that secure the burner box assembly to the vest panel. Remove burner box from the unit.
7. Use the soft brush attachment on a vacuum cleaner to gently clean the face of the burners. Visually inspect the inside of the burners and crossovers for any blockage caused by foreign matter. Remove any blockage.
8. Reinstall the burner box assembly using the existing four screws. Make sure that the burners line up in the center of the burner ports.
9. Reconnect the sensor wire and reconnect the 2 pin plug to the ignitor wiring harness. Reconnect wires to flame rollout switches.
10. Reinstall the gas valve manifold assembly. Reconnect the gas supply line to the gas valve. Reinstall the burner box cover.
11. Reconnect 2 pin plug to gas valve.
12. Replace the blower compartment access panel.
13. Refer to instruction on verifying gas and electrical connections when re-establishing supplies.
14. Follow lighting instructions to light and operate furnace for 5 minutes to ensure that heat exchanger is clean and dry and that furnace is operating properly.
15. Replace heating compartment access panel.

### **Planned Service**

A service technician should check the following items during an annual inspection. Power to the unit must be shut off for the service technician's safety.

**Burners** - Must be inspected for rust, dirt, or signs of water.

**Vent pipe** - Must be inspected for signs of water, cracked, damaged or sagging pipe, or disconnected joints.

**Unit appearance** - Must be inspected for rust, dirt, signs of water, burnt or damaged wires, or components.

**Blower access door** - Must be properly in place and provide a seal between the return air and the room where the furnace is installed.

**Return air duct** - Must be properly attached and provide an air seal to the unit.

**Operating performance** - Unit must be observed during operation to monitor proper performance of the unit and the vent system.

**Combustion gases** - Flue products must be analyzed and compared to the unit specifications.

Problems detected during the inspection may make it necessary to temporarily shut down the furnace until the items can be repaired or replaced.

Instruct the homeowners to pay attention to their furnace. Situations can arise between annual furnace inspections that may result in unsafe operation.

### **Integrated Control Diagnostic Codes**

Press the diagnostic push button and hold it to cycle through a menu of options. Every five seconds a new menu item will be displayed.

Release the button when the desired mode is displayed.

When a solid "P" is displayed, the furnace capacity/ size is programmed.

When the solid "E" is displayed, the control enters the Error Code Recall mode. Error Code Recall mode menu options: No change (displaying error history) remains in Error Code Recall mode; solid "b" exits Error Code Recall mode; and solid "c" clears the error history. Must press button while flashing "c" is displayed to clear error codes.

When the solid "-" is displayed, the control enters the Field Test mode. Field Test mode menu options: Solid "C" starts pressure switch calibration; blinking "-" exits Field Test mode.

| Code | Diagnostic Codes / Status of Equipment   | Action Required to Clear and Recover  |
|------|--|---|
|      | Idle mode (Decimal blinks at 1 Hertz - 0.5 seconds ON, 0.5 seconds OFF).   |   |
| A    | Cubic feet per minute (cfm) setting for indoor blower (1 second ON, 0.5 seconds OFF) / cfm setting for current mode displayed.                     |   |
| C    | Cooling stage (1 second ON, 0.5 seconds OFF) / 1 or 2 displayed / Pause / cfm setting displayed / Pause / Repeat codes.                            |   |
| d    | Dehumidification mode (1 second ON, 1 second OFF) / cfm setting displayed / Pause / Repeat codes.  |   |
| h    | Heat pump stage (1 second ON, 0.5 seconds OFF) / % of input rate displayed / Pause / cfm setting / Pause / Repeat codes.                           |   |
| H    | Gas Heat stage (1 second ON, 0.5 seconds OFF) / 1 or 2 displayed / Pause / cfm setting displayed / Pause / Repeat codes. Blinking during ignition. |   |
| dF   | Defrost mode.  |   |
| E105 | Device communication problem - No other devices on RS BUS (Communication system).  | Equipment is unable to communicate. Indicates numerous message errors. In most cases, errors are related to electrical noise. Make sure high voltage power is separated from RSBus. Check for mis-wired and/or loose connections between the stat, indoor unit, and outdoor unit. Check for a high voltage source of noise close to the system. Fault clears after communication is restored. |
| E110 | Low line voltage.  | Line Voltage low (Voltage lower than nameplate rating). Check power line voltage and correct. Alarm clears 5 seconds after fault recovered.   |
| E113 | High line voltage.   | Line Voltage high (Voltage higher than nameplate rating). Provide power voltage within proper range. System resumes normal operation 5 seconds after fault recovered.   |
| E114 | Line voltage frequency out-of-range.   | No 60 Hertz power. Check voltage and line power frequency. Correct voltage and frequency problems. System resumes normal operation 5 seconds after fault recovered.   |
| E115 | Low 24V - Control will restart if the error recovers.  | 24 Volt Power high (Range is 18 to 30 Volts). Check and correct voltage. Check for additional power robbing equipment connected to system. May require installation of larger VA transformer to be installed in furnace/air handler. Clears after fault recovered.  |
| E120 | Unresponsive device (Communicating systems only).  | Usually caused by delay in outdoor unit responding to indoor unit polling. Recycle power. Check all wiring connections. Cleared after unresponsive device responds to any inquiry.  |
| E124 | Active communicating thermostat signal missing for more than 3 minutes (Communicating systems only).   | Equipment lost communication with the thermostat. Check four wiring connections, ohm wires, and cycle power at the thermostat. Alert stops all services and waits for heartbeat message from thermostat (subnet controller). Cleared after valid thermostat (subnet) message is received.   |

| <b>Code</b> | <b>Diagnostic Codes / Status of Equipment</b>  | <b>Action Required to Clear and Recover</b>   |
|-------------|--|---|
| E125        | Control failed self-check, internal error, failed hardware. Will restart if error recovers, Integrated control not communicating Covers hardware errors (flame sense circuit faults, pin shorts, etc). | Hardware problem on the control. Cycle power on control. Replace if problem prevents service and is persistent. Cleared 300 seconds after fault recovered.  |
| E126        | Control internal communication problem.  | Hardware problem on the control. Cycle power on control. Replace if problem prevents service and is persistent. Cleared 300 seconds after fault recovered.  |
| E131        | Corrupted control parameters (Verify configuration of system) (Communicating systems only).  | Reconfigure the system. Replace control if heating or cooling is not available. Only applicable in the communicating mode not in startup. Exit from Commissioning and Execute Se+ factory Default mode. Control will still operate on default parameter settings.   |
| E180        | Outdoor air temperature sensor failure. Only shown if shorted or out of range (Communicating systems only)   | Compare outdoor sensor resistance to temperature resistance charts in unit installation instructions. Replace sensor pack if necessary. At beginning of (any) configuration, furnace or air handler control will sense outdoor air and discharge air temperature sensor(s) If detected (reading in range), appropriate feature will be set as installed and that could be seen in 'About ' screen. In normal operation after control recognizes sensors, alarm will be sent if valid temperature reading is lost. To get rid of setting and alarm, redo configuration and make sure that temperature sensor is marked as not installed in indoor Unit 'About' screen. When indoor unit control is replaced thermostat will 'tell' new control if temperature sensor is in system or not. Clears 30 seconds after fault recovered. |
| E200        | Hard Lock out - Rollout circuit open or previously open  | Correct cause of rollout trip or replace flame rollout switch. Test furnace operation. Cleared after fault recovered.   |
| E201        | Indoor blower/communication failure - Unable to communicate with blower motor  | Indoor blower communication failure including power outage. Lost communication with indoor blower motor. Possible causes: motor not powered, loose wiring. Problem may be on control or motor side. Cleared after fault recovered.  |
| E202        | Indoor blower motor mismatch - indoor motor horsepower does not match unit capacity  | Incorrect appliance capacity code selected. Check for proper configuring under Unit Size Code for Furnace/ Air Handler on configuration guide or in installation instructions. Cleared after the correct match is detected following a reset. (Remove thermostat from system while applying power and reprogramming)  |
| E203        | Appliance capacity size is NOT programmed. Invalid unit codes. Refer to configuration flow chart.  | No appliance capacity code selected. Check for proper configuring under Unit Size Codes for Furnace on configuration guide or in installation instruction. Critical Alert Cleared after valid unit code is read following a reset (remove thermostat from system while applying power and reprogramming)  |
| E204        | Gas valve mis-wired  | Check gas valve operation and wiring. Clears when repaired  |
| E205        | Gas valve control relay contact shorted  | Check wiring on control and gas valve. If wiring is correct replace control.  |

| <b>Code</b> | <b>Diagnostic Codes / Status of Equipment</b>  | <b>Action Required to Clear and Recover</b>   |
|-------------|--|---|
| E207        | Hot surface igniter sensed open - Refer to troubleshooting                               | Measure resistance of hot surface igniter. Replace if open or not within specified range found in installation/operation manual. Resumes normal operation after fault is cleared.   |
| E223        | Low pressure switch failed open  | Check pressure(inches W.C) of low pressure switch closing on heat call. Measure operating pressure (inches w.c.). Inspect vent and combustion air inducer for correct operation and restriction. Resumes normal operation after fault is cleared. |
| E224        | Low pressure switch failed closed -Refer to troubleshooting                              | Check pressure(inches W.C) of low pressure switch closing on heat call. Measure operating pressure (inches w.c.). Inspect vent and combustion air inducer for correct operation and restriction. Resumes normal operation after fault is cleared. |
| E225        | High pressure switch failed open -Refer to troubleshooting                               | Check pressure(inches W.C) of high pressure switch closing on heat call. Measure operating pressure (inches w.c. Inspect vent and combustion air inducer for correct operation and restriction Resumes normal operation after fault is cleared.   |
| E226        | High pressure switch failed closed -Refer to troubleshooting                             | Check operation of high pressure closing on heat call. Measure operating pressure (inches w.c.). Inspect vent and combustion air inducer for correct operation and restriction. Resumes normal operation after fault is cleared.                  |
| E227        | Low pressure switch open during trial for ignition or run mode. Refer to troubleshooting | Check operation of low pressure switch closing on heat call. Measure operating pressure (inches w.c.). Inspect vent and combustion air inducer for correct operation and restriction. Resumes normal operation after fault is cleared.            |
| E228        | Combustion air inducer calibration failure   | Unable to perform pressure switch calibration. Check vent system and pressure switch wiring connections. Resumes normal operation after fault is cleared  |
| E229        | Ignition on high fire  | IFC switched to high fire ignition because low fire pressure switch did not close in allowed time. No action is needed.   |
| E240        | Low flame current - Run mode- Refer to troubleshooting                                   | Check micro-amperes of flame sensor using control diagnostics or field installed mode. Clean or replace sensor. Measure voltage of neutral to ground to ensure good unit ground. Alert clears after current heat all has been completed.          |
| E241        | Flame sensed out of sequence-Flame still present.  | Shut off gas. Check for gas valve leak. Replace if necessary. Alert clears when fault is recovered.   |
| E250        | Limit switch circuit open - Refer to troubleshooting.                                    | Check for proper firing rate on furnace. Ensure there is no blockage in heater. Check for proper air flow. If limit not closed within 3 minutes unit will go into 1 hour soft lockout. Resumes normal operation after fault is cleared.           |
| E252        | Discharge air temperature too high (gas heat only).                                      | Check temperature rise airflow and input rate. Clear when heat call is finished.  |
| E270        | Soft lockout - Exceeded maximum number of retries. No flame current sensed.              | Check for proper gas flow. Ensure that igniter is lighting burners. Check flame sensor current. Clears when heat call finishes successfully.  |

| Code | Diagnostic Codes / Status of Equipment   | Action Required to Clear and Recover  |
|------|--|---|
| E271 | Soft lockout - Exceeded maximum number of retries. Last retry failed due to the pressure switch opening.   | Check pressure (inches w.c.) of low pressure switch closing on heat call. Measure operating pressure (inches w.c.). Inspect vent and combustion air inducer for correct operation and restriction. Clears when heat call finishes successfully.   |
| E272 | Soft lockout - Exceeded maximum number of recycles. Last recycle due to the pressure switch opening  | Check operation of low pressure to see if it is stuck closed on heat call. Check pressure (inches w.c.) of high pressure switch closing on heat call. Measure operating pressure. Inspect vent and combustion air inducer for correct operation and restriction. Clears when heat call finishes successfully. |
| E273 | Soft lockout - Exceeded maximum number of recycles. Last recycle due to flame failure  | Check micro-amperes of flame sensor using control diagnostics or field installed mode. Clean or replace sensor. Measure voltage of neutral to ground to ensure good unit ground. Alert clears after current heat call has been completed.   |
| E274 | Soft lockout - Exceeded maximum number of recycles. Last recycle failed due to the limit circuit opening or limit remained open longer than 3 minutes. | Shut down system 1-hour soft lockout. Check firing rate and air flow. Check for blockage. Clears when heat call finishes successfully.  |
| E275 | Soft lockout - Flame sensed out of sequence. Flame signal is gone.   | Shut off gas. Check for gas valve leak. 1-hour soft lockout. Clears when flame has been proven stable.  |
| E276 | Soft lockout calibration failure.  | Unable to perform pressure switch calibration. Check vent system and pressure switch wiring connections. 1-hour soft lockout. Clears when calibration has finished successfully.  |
| E290 | Ignitor circuit fault - Failed ignitor or triggering circuitry.  | Measure resistance of hot surface igniter. Replace if open or not within specifications. 1-hour soft lockout. Clears when flame has been proven stable.   |
| E291 | Heat airflow restricted below the minimum.   | Check for dirty filter and airflow restriction. Check blower performance. 1-hour soft lockout. Cleared when heat call finishes successfully.  |
| E292 | Indoor blower motor unable to start due to obstructed wheel seized bearings.   | Indoor blower motor unable to start (seized bearing, stuck wheel, etc.) Replace motor or wheel if assembly does not operate or meet performance standards. 1-hour soft lockout. Clears after circulator successfully starts.  |
| E294 | Combustion air inducer over current.   | Check combustion blower bearings wiring and amps. Replace if does not operate or does not meet performance standards. Clears after inducer current is sensed to be in-range after the ignition following the soft lockout or reset.   |
| E295 | Indoor blower motor temperature is too high.   | Indoor blower motor over temperature (motor tripped on internal protector). Check motor bearings and amps. Replace if necessary. Cleared after blower demand is satisfied.  |
| E310 | Discharge error temperature sensor failure. Only shown if shorted or out of range.   | Compare discharge sensor resistance to temperature resistance charts in installation instructions.. Replace sensor if necessary. Cleared in Communicating mode 30 seconds after fault recovered. In Non-Communicating mode cleared after the current heat call is completed.                                  |

| Code | Diagnostic Codes / Status of Equipment  | Action Required to Clear and Recover   |
|------|---|--|
| E311 | Heat rate reduced to match indoor blower airflow.   | Warning Only. Furnace blower in cutback mode due to restricted airflow. Reduce firing rate every 60 seconds to match available CFM. Check filter and duct system. To clear replace filter if needed or repair/add duct. 2-stage controls will reduce firing rate to 1-stage. Clears when heat call finished successfully.  |
| E312 | Restricted airflow in cooling or continuous fan mode is lower than CFM setting.   | Warning Only. Restricted airflow - Indoor blower is running at a reduced CFM (Cutback Mode - The variable speed motor has pre-set speed and torque limiters to protect the motor from damage caused by operating outside of design parameters (0 to 0.8" W.C. total external static pressure). Check filter and duct system. To clear, replace filter if needed or repair/add duct. Cleared after the current service demand is satisfied. |
| E313 | Indoor or outdoor unit capacity mismatch. Communication only.   | Incorrect indoor/outdoor capacity code selected. Check for proper configuring in installation instructions. Alarm is just a warning. The system will operate, but might not meet efficiency and capacity parameters. Alarm will clear when commissioning is complete.  |
| E331 | Global network connection - Communications link problem.  | For Future Use.  |
| E347 | No 24 Volt output on Y1 of "integrated control" with non-communicating outdoor unit.  | Operation stopped. Y1 relay/Stage 1 failed. (Pilot relay contacts did not close or the relay coil did not energize; no input back to IFC chip.) Critical Alert. Cleared after reset and Y1 input sensed.   |
| E348 | No 24 Volt output on Y2 of "integrated control" with non-communicating outdoor unit.  | Y2 relay/Stage 2 failed. (Pilot relay contacts did not close or the relay coil did not energize; no input back to IFC chip.) Critical Alert. Cleared after reset and Y1 input sensed.  |
| E349 | No 24 Volts between R & O on "integrated control" with non-communicating outdoor unit (dual fuel model required for heat pump application). | Configuration link R to O needs to be restored. Replace link or hardware. Applicable in non-communicating mode. Critical Alert.  |
| E401 | LSOM - Compressor long run cycle or low system pressure.  | Compressor ran more that 18 hours to satisfy a single thermostat demand. Critical Alert. Clears the error after 30 consecutive normal run cycles or power reset. Also monitors low pressure switch trips.  |
| E402 | LSOM - Outdoor unit system pressure trip.   | Discharge or suction pressure out-of-limits, or compressor overloaded. Clears the error after 4 consecutive normal compressor run cycles.  |
| E403 | LSOM - Compressor short-cycling (Running less than 4 minutes). Outdoor unit pressure trip.  | Compressor runs less than 3 minutes to satisfy a thermostat demand. Clears the error after 4 consecutive normal run cycles or power reset.   |
| E404 | LSOM - Compressor rotor locked. Compressor short-cycling. (Running less than 4 minutes.)  | Compressor rotor locked up due to run capacitor short, bearings are seized, excessive liquid refrigeration, etc. Clears the error after 4 consecutive normal run cycles or power reset.  |
| E405 | LSOM - Compressor open circuit.   | Compressor circuit open (due to power disconnection, open fuse, etc.) Clears the error after 1 normal compressor run cycle.  |
| E406 | LSOM - Compressor open start circuit.   | Required amount of current is not passing through Start current transformer. Clears the error after current is sensed in START sensor, or after power reset.   |

| Code | Diagnostic Codes / Status of Equipment | Action Required to Clear and Recover   |
|------|--|--|
| E407 | LSOM - Compressor open run circuit.    | Required amount of current is not passing through Run current transformer. Clears the error after current is sensed in RUN sensor, or 1 normal compressor run cycle, or after power reset. |
| E408 | LSOM - Compressor contactor is welded. | Compressor runs continuously. Clears the error after 1 normal compressor run cycle or after power reset.   |
| E409 | LSOM - Compressor low voltage.         | Secondary voltage is below 18VAC. After 10 minutes, operation is discontinued. Clears the code after voltage is higher than 20VAC for 2 seconds or after power reset.                      |



## Repair Parts List

The following repair parts are available through Allied Air distributors. When ordering parts, include the complete furnace model number listed on the nameplate. All service must be performed by a licensed professional installer (or equivalent), service agency, or gas supplier.

### Cabinet Parts

- Outer Access Panel
- Blower Access Panel
- Top Cap

### Control Panel Parts

- Transformer
- Integrated Control Board
- Door Interlock Switch
- Circuit Breaker

### Blower Parts

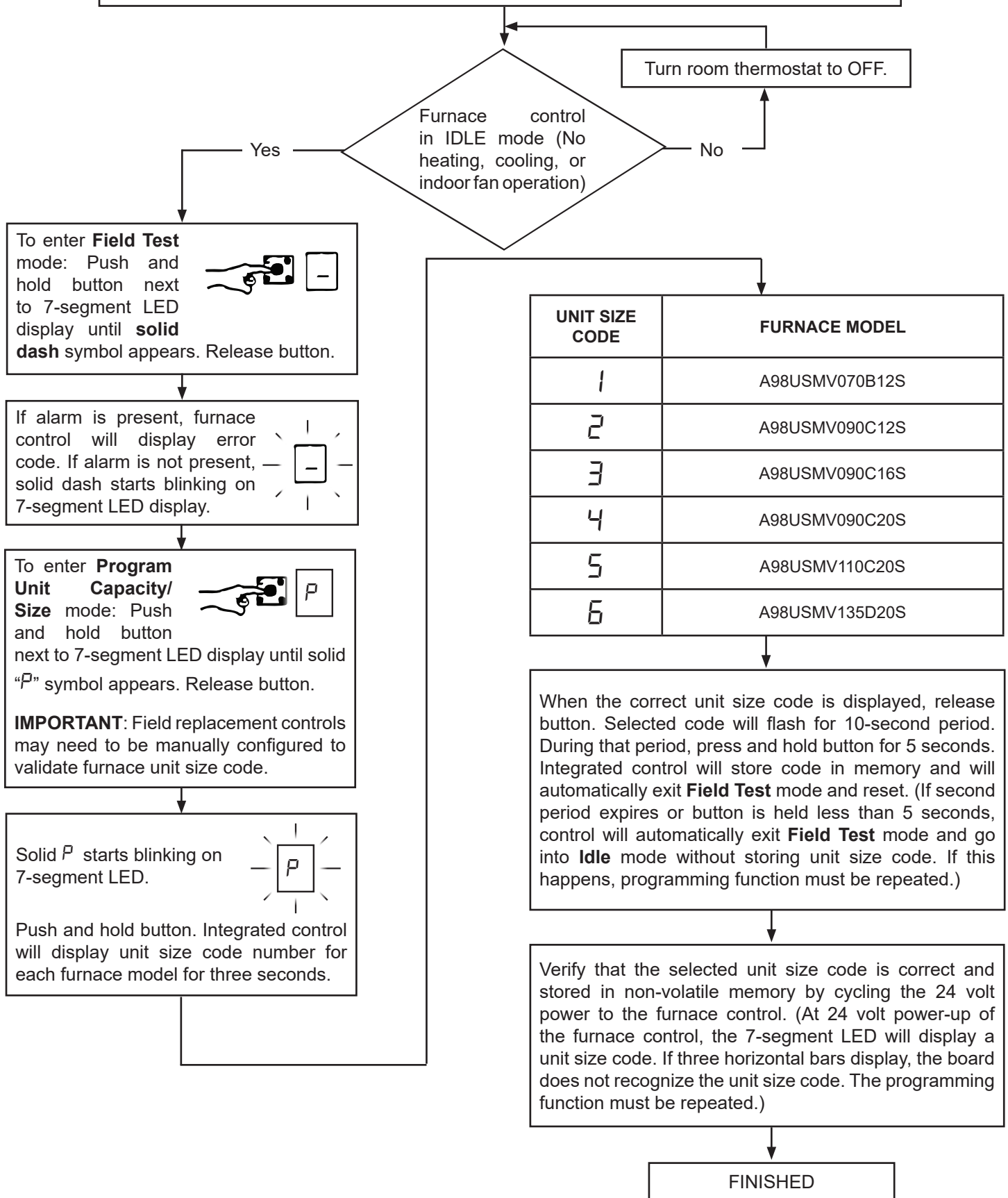
- Blower Wheel
- Motor
- Motor Mounting Frame
- Blower Housing Cut Off Plate
- Power Choke (1 HP only)

### Heating Parts

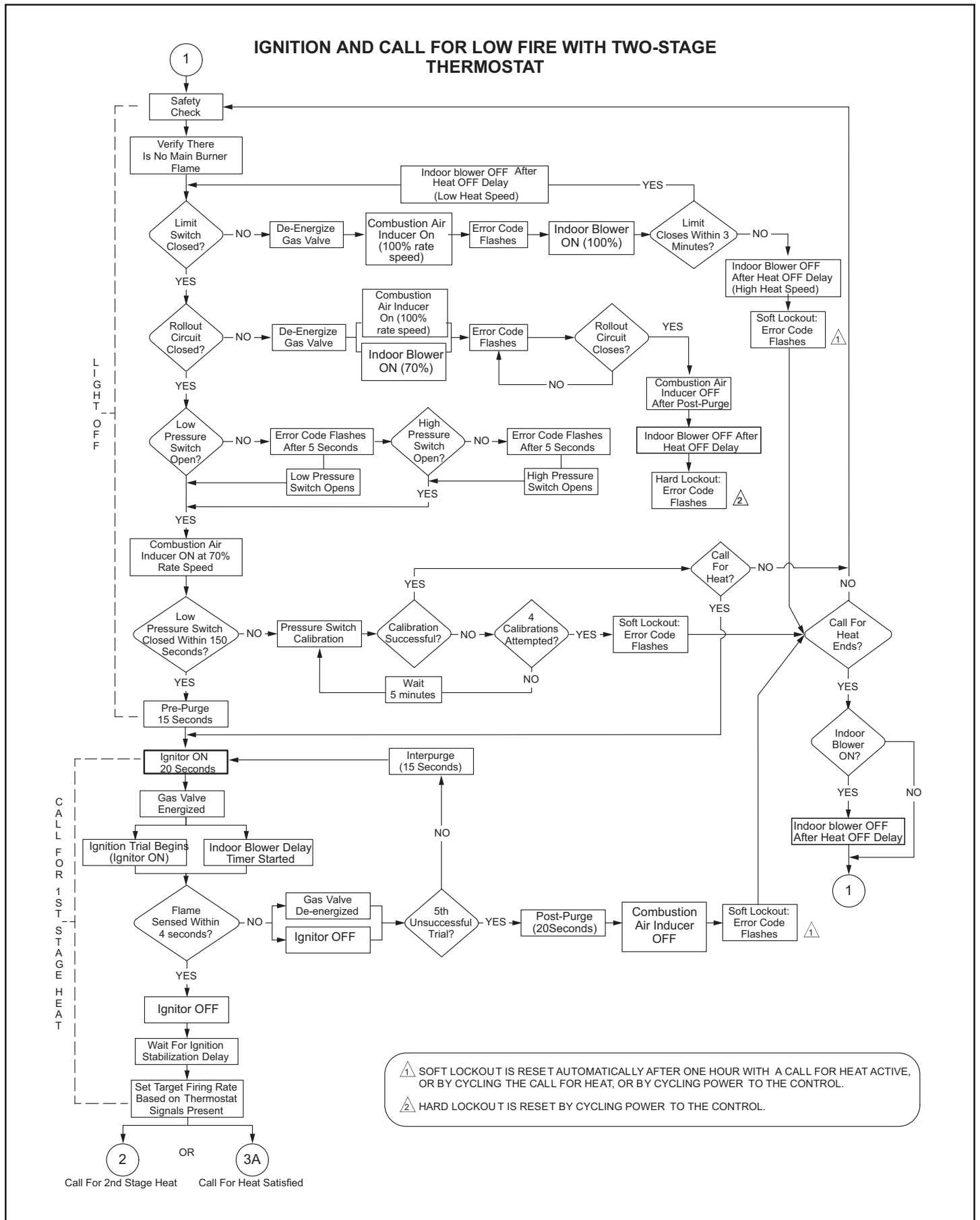
- Flame Sensor
- Heat Exchanger Assembly
- Gas Manifold
- Combustion Air Inducer
- Gas Valve
- Main Burner Cluster
- Main Burner Orifices
- Pressure Switch
- Ignitor
- Primary Limit Control
- Flame Rollout Switches

## Program Unit Capacity / Size Mode

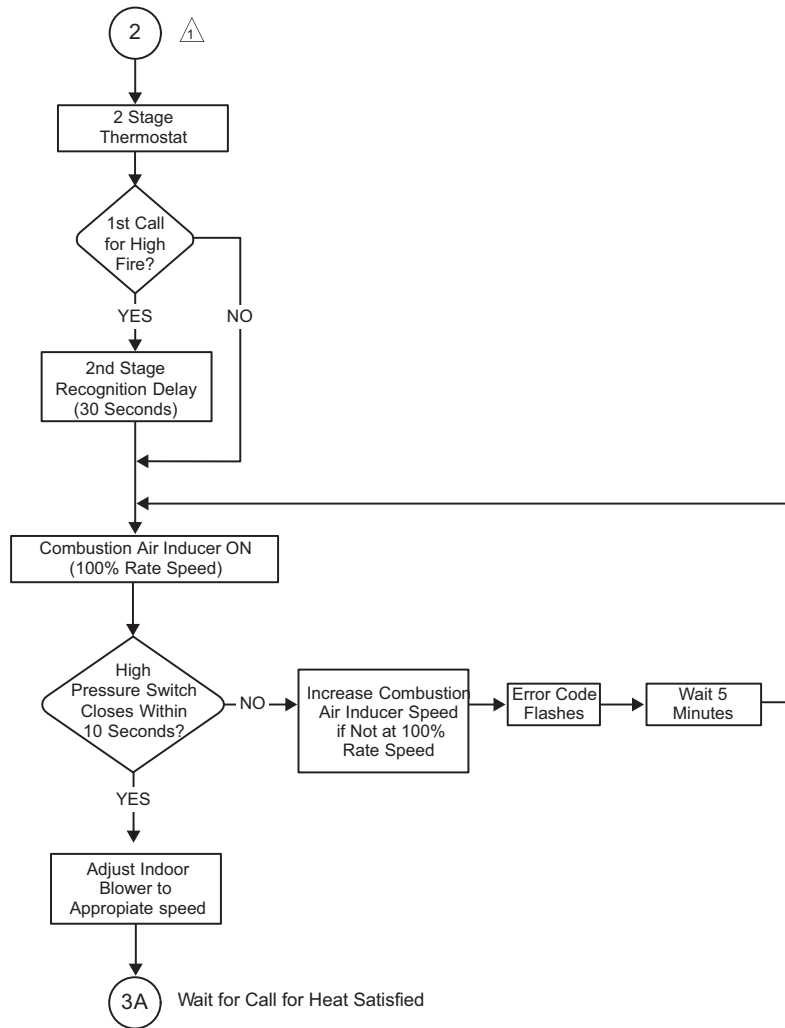
Power-Up - Number displayed by integrated control represents unit size code (furnace model and capacity). If three horizontal bars are displayed followed by continuous E203, furnace control does not recognize unit size code. Configure per the following:



# Troubleshooting: Heating Sequence of Operation



**CALL FOR HIGH FIRE WITH TWO-STAGE THERMOSTAT**



⚠ System will always light at 70% even if 2nd stage call for heat is in place

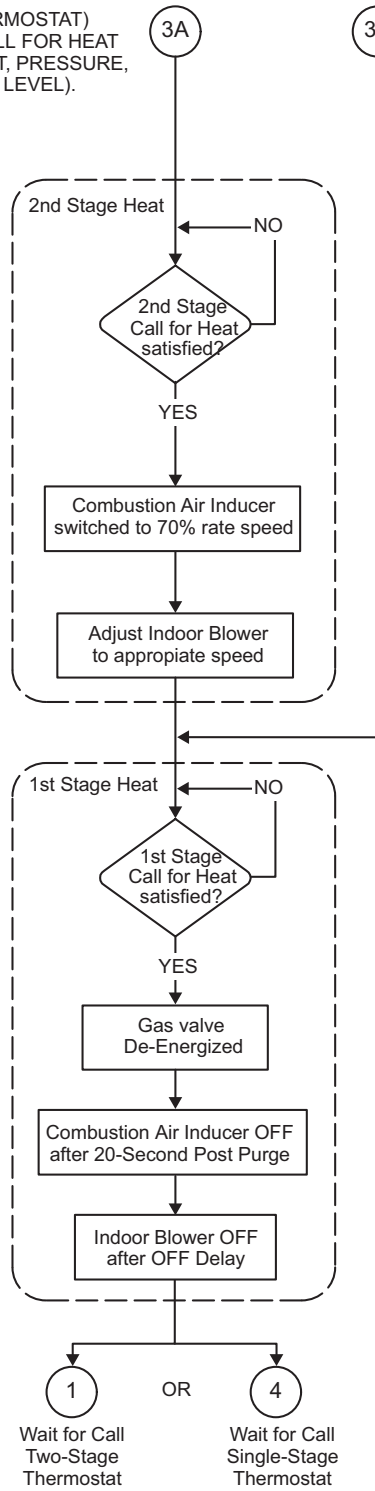
⚠ If the high pressure switch does not close within 5 attempts, the system will operate at low fire for the remainder of the call for heat at request

Troubleshooting: Heating Sequence of Operation (continued)

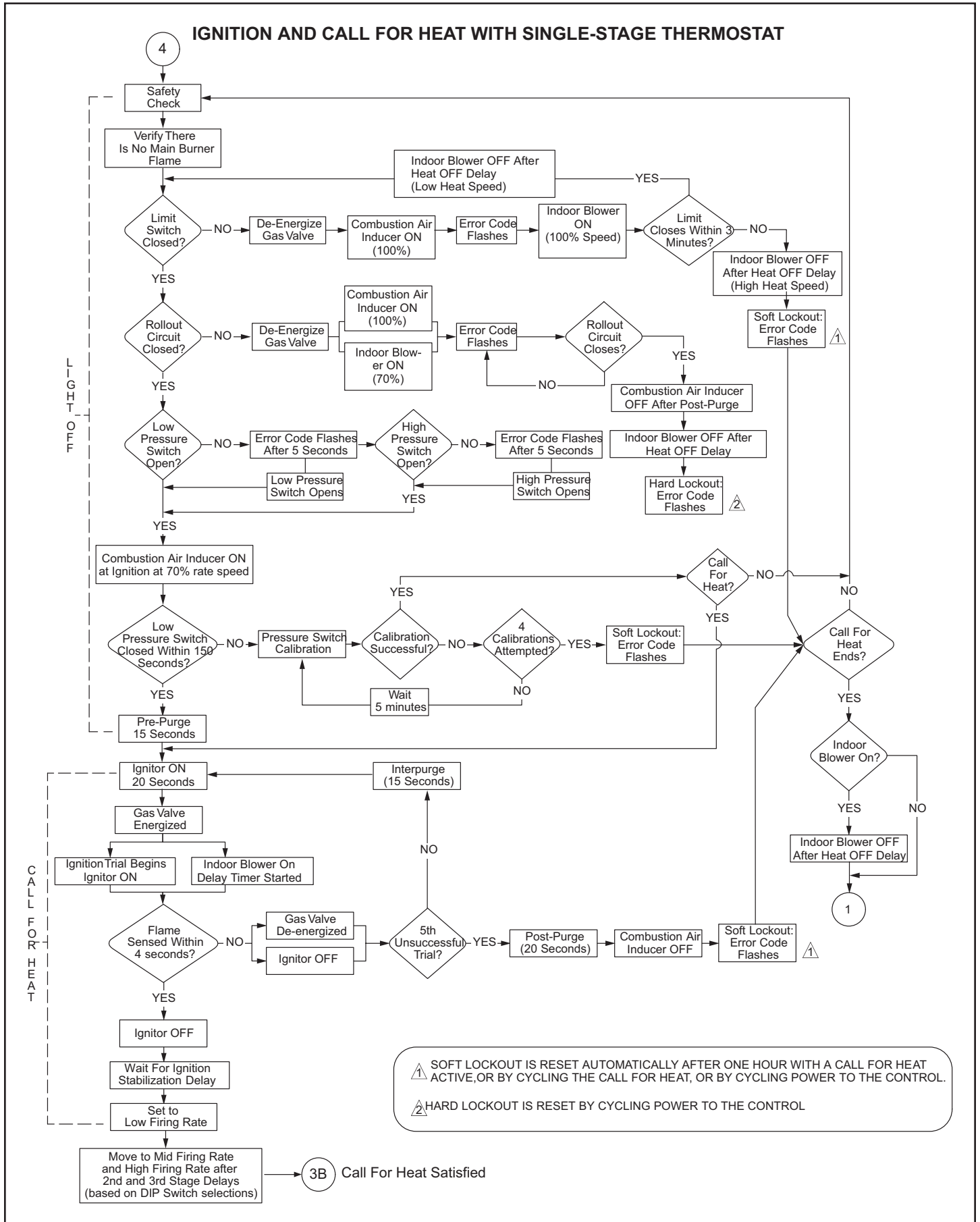
Call for Heat Satisfied

RUN MODE (TWO-STAGE THERMOSTAT)  
FIRST OR SECOND-STAGE CALL FOR HEAT  
ALL INPUTS MONITORED (LIMIT, PRESSURE,  
CALL FOR HEAT/COOL, FLAME LEVEL).

RUN MODE (SINGLE-STAGE THERMOSTAT)  
ALL INPUTS MONITORED (LIMIT, PRESSURE,  
CALL FOR HEAT/COOL, FLAME LEVEL).

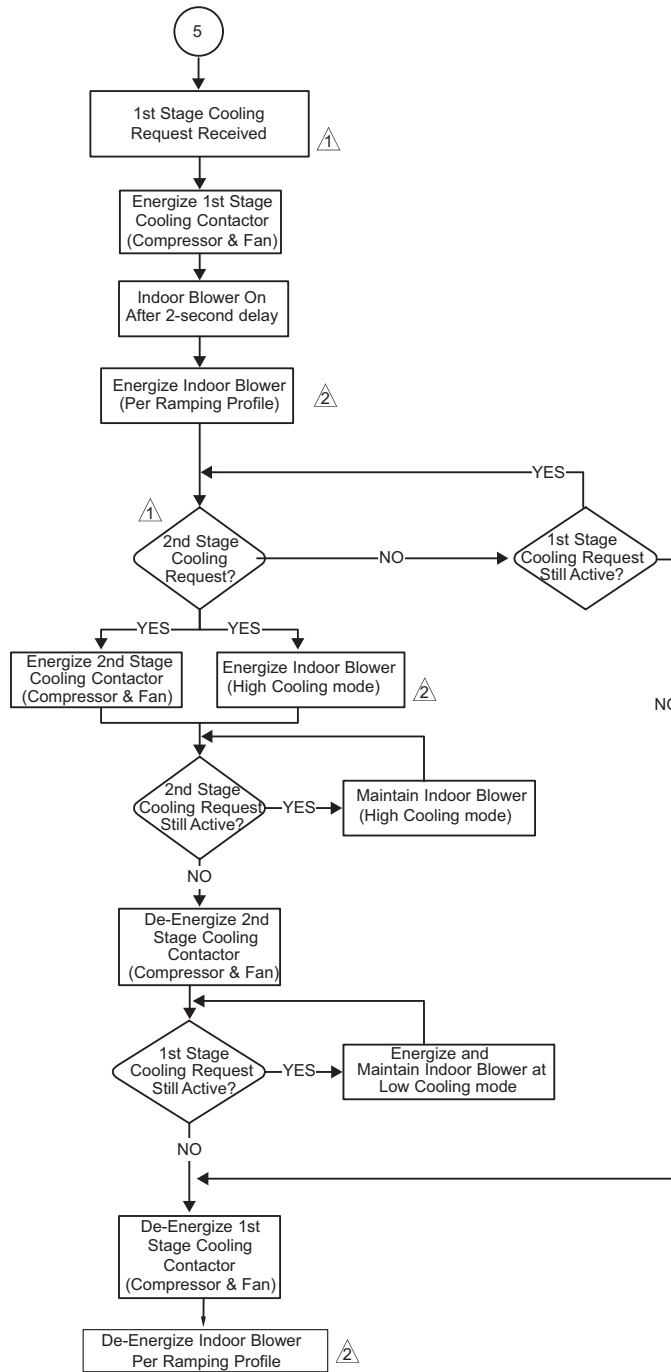


Troubleshooting: Heating Sequence of Operation (continued)



## Troubleshooting: Cooling Sequence of Operation

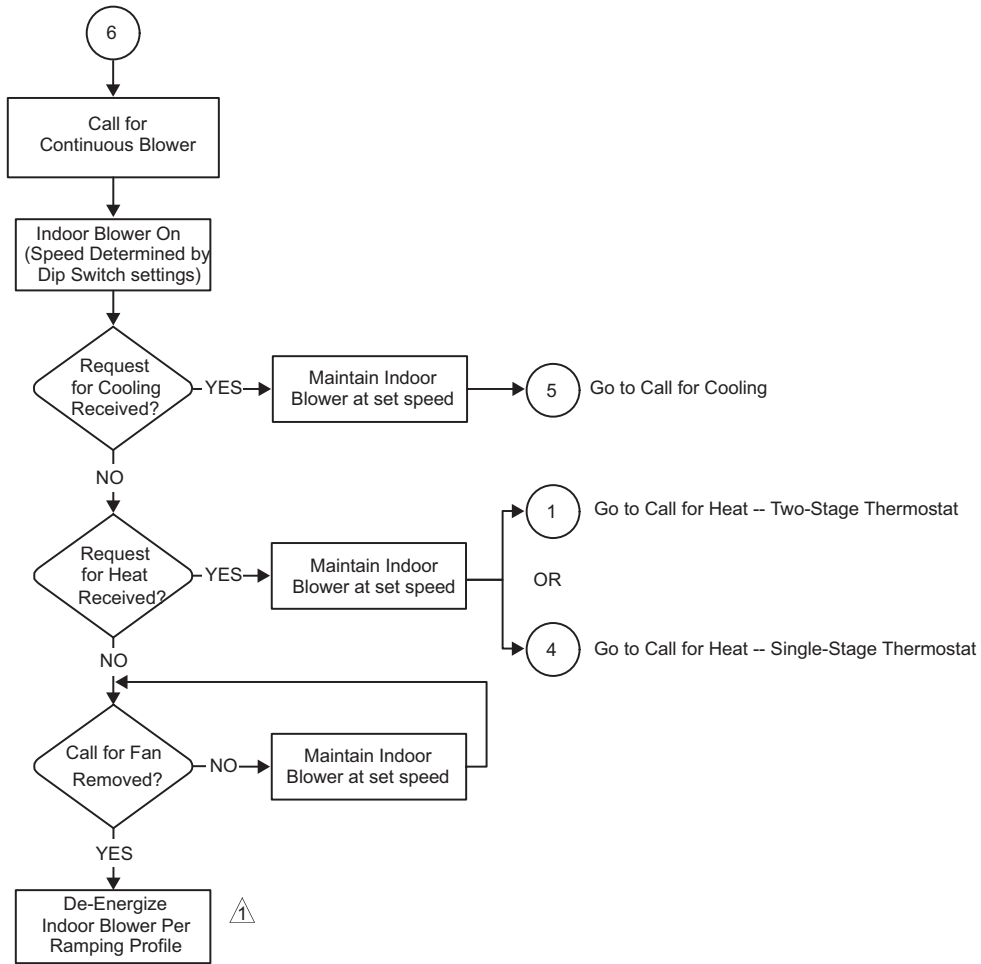
### CALL FOR COOLING



⚠ 2nd stage cooling operation requires a 2-stage thermostat, a 2-stage cooling system and on-board link W915 must be cut. The control will not respond to a 2nd stage cooling request unless a 1st stage cooling request is active

⚠ Indoor blower cooling mode and high cooling mode have a specific ON, OFF and speed ramping profiles. The specific profile is selected using the DIP switches on the control.

**CONTINUOUS LOW SPEED INDOOR BLOWER SEQUENCE OF OPERATION**



⚠ Indoor blower low cooling mode and high cooling mode, have specific ON - OFF and speed ramping profiles. The specific profile is selected using the dip switches on the control.



## Requirements for Commonwealth of Massachusetts

### Modifications to NFPA-54, Chapter 10

#### Revise NFPA-54 section 10.8.3 to add the following requirements:

For all side wall, horizontally vented, gas-fueled equipment installed in every dwelling, building or structure used in whole or in part for residential purposes, including those owned or operated by the Commonwealth and where the side wall exhaust vent termination is less than seven (7) feet above the finished grade in the area of the venting, including but not limited to decks and porches, the following requirements shall be satisfied:

1. **INSTALLATION OF CARBON MONOXIDE DETECTORS.** At the time of installation of the side wall, horizontally vented, gas-fueled equipment, the installing plumber or gas fitter shall observe that a hard-wired carbon monoxide detector with an alarm and battery backup is installed on the floor level where the gas equipment is to be installed. In addition, the installing plumber or gas fitter shall observe that a battery-operated or hard-wired carbon monoxide detector with an alarm is installed on each additional level of the dwelling, building or structure served by the side wall, horizontally vented, gas-fueled equipment. It shall be the responsibility of the property owner to secure the services of qualified licensed professionals for the installation of hard-wired carbon monoxide detectors.
  - a. In the event that the side wall, horizontally vented, gas-fueled equipment is installed in a crawl space or an attic, the hard-wired carbon monoxide detector with alarm and battery backup may be installed on the next adjacent floor level.
  - b. In the event that the requirements of this subdivision cannot be met at the time of completion of installation, the owner shall have a period of thirty (30) days to comply with the above requirements; provided, however, that during said thirty (30) day period, a battery-operated carbon monoxide detector with an alarm shall be installed.
2. **APPROVED CARBON MONOXIDE DETECTORS.** Each carbon monoxide detector as required in accordance with the above provisions shall comply with NFPA 720 and be ANSI/UL 2034 listed and IAS certified.
3. **SIGNAGE.** A metal or plastic identification plate shall be permanently mounted to the exterior of the building at a minimum height of eight (8) feet above grade directly in line with the exhaust vent terminal for the horizontally vented, gas-fueled heating appliance or equipment. The sign shall read, in print size no less than one-half (1/2) inch in size, **"GAS VENT DIRECTLY BELOW. KEEP CLEAR OF ALL OBSTRUCTIONS."**

4. **INSPECTION.** The state or local gas inspector of the side wall, horizontally vented, gas-fueled equipment shall not approve the installation unless, upon inspection, the inspector observes carbon monoxide detectors and signage installed in accordance with the provisions of 248 CMR 5.08(2)(a) 1 through 4.

#### **EXEMPTIONS: The following equipment is exempt from 24 CMR 5.08(2)(a) 1 through 4:**

1. The equipment listed in Chapter 10 entitled "Equipment Not Required to Be Vented" in the most current edition of NFPA 54 as adopted by the Board; and
2. Product Approved side wall, horizontally vented, gas-fueled equipment installed in a room or structure separate from the dwelling, building or structure used in whole or in part for residential purposes.

#### **MANUFACTURER REQUIREMENTS - GAS EQUIPMENT VENTING SYSTEM PROVIDED.**

When the manufacturer of Product Approved side wall, horizontally vented, gas-fueled equipment provides a venting system design or venting system components with the equipment, the instructions provided by the manufacturer for installation of the equipment and the venting system shall include:

1. Detailed instructions for the installation of the venting system design or the venting system components: and
2. A complete parts list for the venting system design or venting system.

#### **MANUFACTURER REQUIREMENTS - GAS EQUIPMENT VENTING SYSTEM NOT PROVIDED.**

When the manufacturer of Product Approved sidewall, horizontally vented, gas-fueled equipment does not provide the parts for venting the flue gases, but identifies "special venting systems," the following requirements shall be satisfied by the manufacturer:

1. The referenced "special venting system" instructions shall be included with the appliance or equipment installation instructions; and
2. The "special venting systems" shall be Product Approved by the Board, and the instructions for that system shall include a parts list and detailed installation instructions.

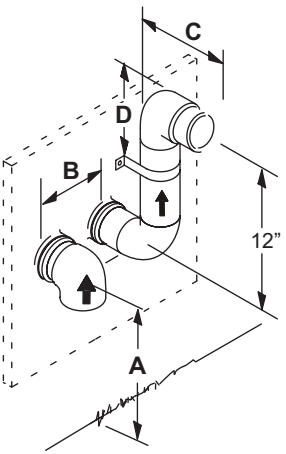
**A copy of all installation instructions for all Product Approved side wall, horizontally vented, gas-fueled equipment, all venting instructions, all parts lists for venting instructions, and/or all venting design instructions shall remain with the appliance or equipment at the completion of the installation.**

**For the Province of Ontario, Horizontal Sidewall Vent Applications Only**

For exterior horizontal venting applications, the 2" X 1.5" reducer for 2" venting at the point where the exhaust pipe exits the structure is not required in direct or nondirect vent applications in the Province of Ontario. In these applications, the vent should be oriented such that the exhaust plume is unobjectionable. If the installation requires more separation between the flue gases and the building structure, a reducer may be installed on the exhaust pipe to increase the flue gas velocity.

**Addendum for All Provinces of Canada**

See below for venting for all provinces of Canada. Allied approves the following termination for use in all provinces of Canada.



|   | <b>2" (51MM)<br/>Vent Pipe</b>        | <b>3" (76MM)<br/>Vent Pipe</b>        |
|---|---------------------------------------|---------------------------------------|
| <b>A</b> – Clearance above grade or average snow accumulation           | 12" (305 mm) Min.                     | 12" (305 mm) Min.                     |
| <b>B</b> – Horizontal separation between intake and exhaust             | 6" (152 mm) Min.<br>24" (610 mm) Max. | 6" (152 mm) Min.<br>24" (610 mm) Max. |
| <b>C</b> – Exhaust pipe length  | Per: Saskatchewan Code of Practice    |                                       |
| <b>D</b> – Wall support distance from top of each pipe (intake/exhaust) | 6" (152 mm) Max.                      | 6" (152 mm) Max.                      |

**NOTE** – Flue gas may be acidic and may adversely affect some building materials. If flue gases impinge on the building materials, a corrosion-resistant shield should be used to protect the wall surface. The shield should be constructed using wood, sheet metal or other suitable material. All seams, joints, cracks, etc. in affected area, should be sealed using an appropriate sealant.